

ENVISIONING **CENTRALVILLE** LOWELL, MASSACHUSETTS

Community Growth and Land Use | Fall 2005

Massachusetts Institute of Technology
City Design and Development Group
Department of Urban Studies and Planning

ENVISIONING CENTRALVILLE

MIT | FALL 2005
department of urban studies and planning



INTRODUCTION

Lowell, Massachusetts' Division of Planning and Development (DPD) has engaged the Community Growth and Land-Use Planning course of MIT (11.360) in the fall of 2005 to envision redevelopment along the Bridge Street Corridor and in surrounding residential areas in the Centralville Neighborhood and recommend implementation strategies to make the plan a reality. Keeping with the smart-growth principles of vibrant and walkable neighborhoods for all of its citizens, the project is designed to promote and enhance the character of the existing Centralville neighborhood.

BRIDGE STREET

SIXTH STREET

**NEIGHBORHOOD
NODES AND FABRIC**

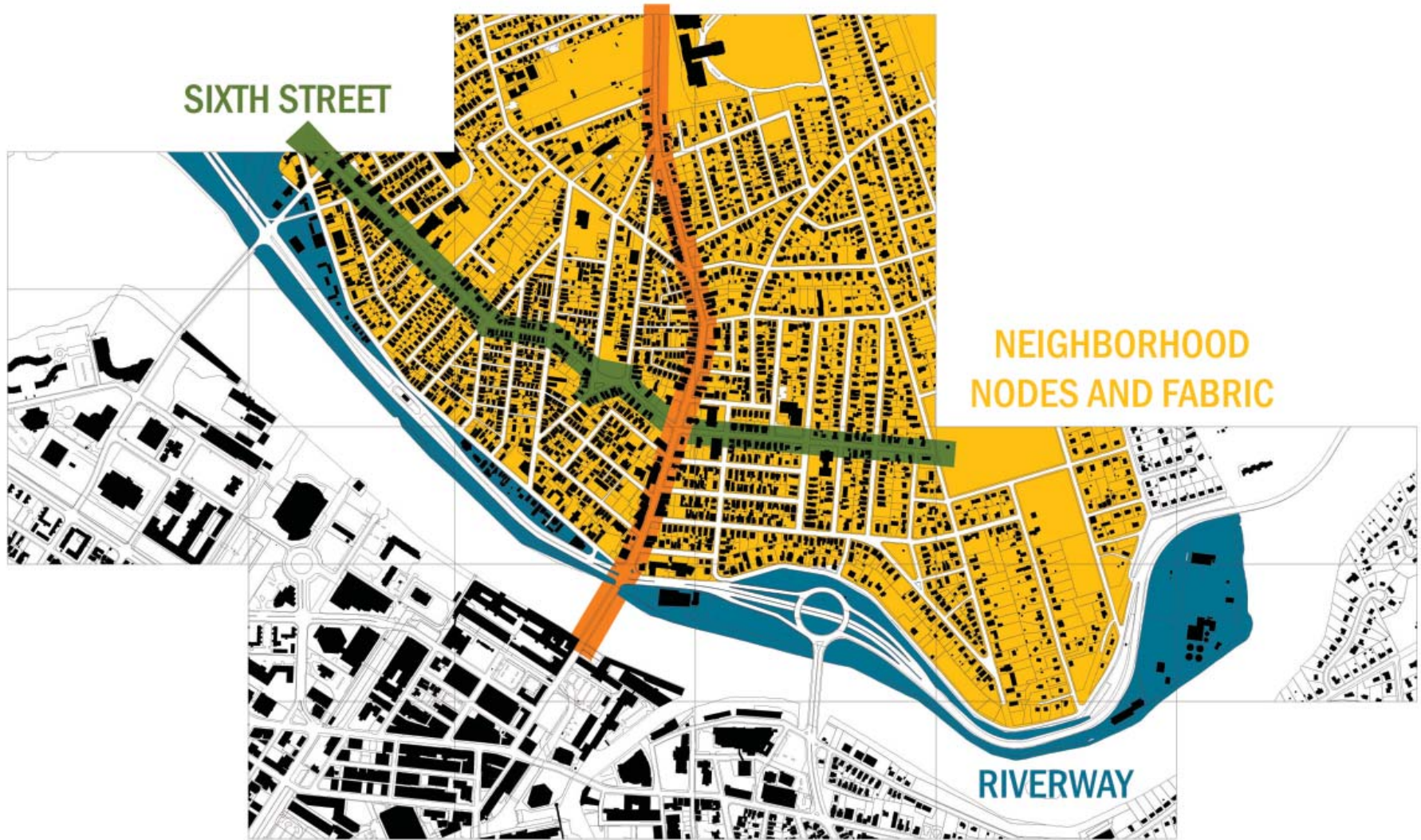

DOWNTOWN HISTORIC LOWELL

TABLE OF CONTENTS

INTRODUCTION	i
BACKGROUND & PROJECT AREA	v
SCOPE OF WORK	vi
NEIGHBORHOODS AND NODES	1
INTERVENTIONS ALONG SIXTH AND WEST SIXTH STREETS	13
VISION FOR THE LOWER BRIDGE STREET COMMERCIAL DISTRICT	27
A VISION FOR CENTRALVILLE'S RIVERWAY	49
EVENT PROGRAMMING	71
CONCLUSIONS [ACDODGE]	79
AFTERWORD	91



BACKGROUND & PROJECT AREA

Since its inception, Lowell, Massachusetts has been a port of entry for new immigrants from around the world looking for a better way of life. These new arrivals have helped to shape the character of the City's neighborhoods, and remain an integral part of Lowell's past and future. Diversity is key to Lowell's identity, and the City works to maintain a population characterized by diverse incomes and ethnic backgrounds as an essential component of the community's character and revitalization.

To attain these goals, Lowell continues to focus on protecting and improving streetscapes, neighborhood commercial centers, natural areas, and public squares, as well as public safety, education, recreation, and other municipal services, as codified in the Comprehensive Master Plan (2003) and recently adopted Zoning Code and Map. These documents and related initiatives are designed to enhance and promote the historic and cultural character of the City and its neighborhoods and ensure a high quality of life for current and future generations.

A short walk north across the Merrimack River from the historic downtown area is Centralville, an ethnically diverse, working-class neighborhood. At the heart of the neighborhood is Bridge Street, which connects downtown with Dracut to the north and provides businesses critical access to the downtown and the rest of the city's roadway network. Bridge Street's first commercial activity dates to 1870 with neighborhood grocery stores and butcher shops. Nowadays, a number of in-fill opportunities are present along Bridge Street. Given Lowell's commitment to its neighborhoods, the city is seeking recommendations on what type of in-fill is appropriate and beneficial for the neighborhood and what interventions the city might make to make that vision reality.

Student work in the course principally addresses the neighborhood business zone and adjacent residential neighborhood along Bridge Street between the Merrimack River and the Robinson Middle School.





SCOPE OF WORK

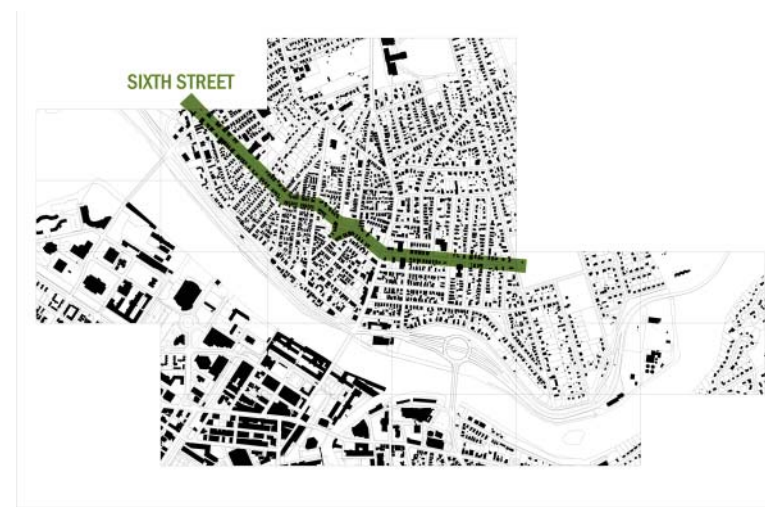

Three layers of questions were suggested by the Lowell DPD:

- What is an appropriate vision for the neighborhood?
- What interventions can the city make to encourage that vision?
- How might the city finance those interventions?

The context for these questions is provided by the city's Comprehensive Master Plan, which places priority on protecting and enhancing the unique character of the neighborhoods, as well as weaving together residential and commercial districts.

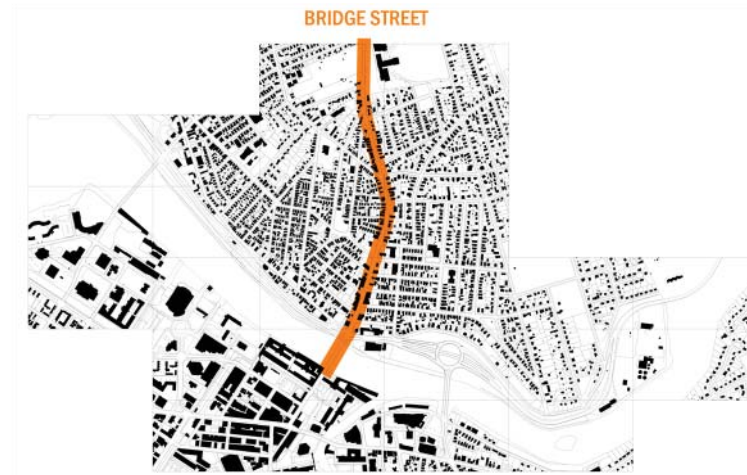
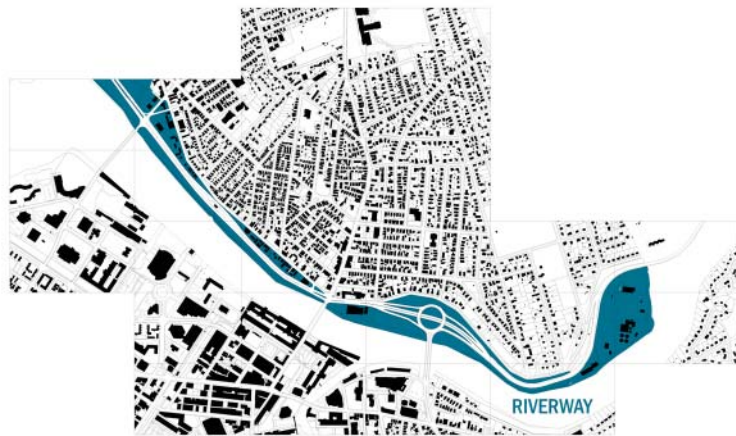

The Envisioning Centralville Plan addresses the question of redevelopment along the Bridge Street Corridor and the surrounding neighborhood by tackling the following questions:

- What are appropriate in-fill projects for the key parcels in the district?
- Are the current zoning codes and guidelines sufficient for the district? Specifically, how can the NB (Neighborhood Business) zoning district serve to ensure that it preserves walkable neighborhood-oriented retail and mixed-use within its borders?
- What type of specific interventions (e.g. pedestrian improvements, way finding, parking improvements, green space, traffic calming, etc.) can the city make in order to encourage appropriate projects?
- What regulatory tools can the City use to protect and enhance the goals of the Master Plan and the proposals in the 'Envisioning Centralville' plan?
- What costs are involved in implementing the aforementioned interventions?
- What is the added value to the neighborhood from the projects in question? And what are the risks involved (e.g. Gentrification)?





Figure 1:
Centralville as Districts, Nodes, Paths, Edges and Landmarks.
Base Map Source: Lowell Division for Planning and Development

NEIGHBORHOODS AND NODES

The Neighborhoods and Nodes group examined Centralville as a discrete neighborhood made up of several overlapping districts, each of which is centered around a node of activity. With this broad frame of reference, we visited the community and found that Centralville is a vibrant and active place with a strong sense of place. We also noticed that the community had a well-preserved and attractive housing stock, a unique but navigable street pattern, and a friendly population. We believe that Centralville is a community that works, and that our job as planners is to protect what works, celebrate what's worth celebrating, and implement strategies to preserve and enhance these qualities.

Neighborhood and Character Districts

The current zoning in Centralville establishes a sound framework for codes based on the intrinsic character of each respective neighborhood. We observed distinct architecture, typologies, building set-backs, street widths, streetscapes, landscapes and parking patterns that make each respective district unique. For these reasons we call these distinct neighborhoods Character Districts. By comparing a 2005 map of Centralville to a 1907 Sanborn Map, we also found that there have been remarkably few changes made to street patterns and building footprints over the last century.

This continuity in built form gives Centralville a remarkable sense of place and is one of the community’s greatest assets. In order to preserve this asset, we recommend that the city create a Citizen Design Review Board to guarantee that new developments are built to a size and scale that’s appropriate to the neighborhood’s fabric.

We observed that the official zoning of a neighborhood did not always align with the Character Districts, as defined by both the built fabric of a neighborhood and the usage patterns of people who live there. Communities often span these “place-based” boundaries, suggesting the need for an additional layer of thinking and planning on top of the existing zoning code. It is important to recognize that character districts are both place-based and community-based, although the two are not always necessarily one in the same. Because having such diverse neighborhoods enriches the overall community fabric, it is important to preserve this character by putting in place a participatory process to establish a vision for Centralville and a definition for the boundaries that define the districts. A Citizen Design Review Board would be a good vehicle to accomplish these goals.



Figure 2:
Examples of Neighborhood Fabric

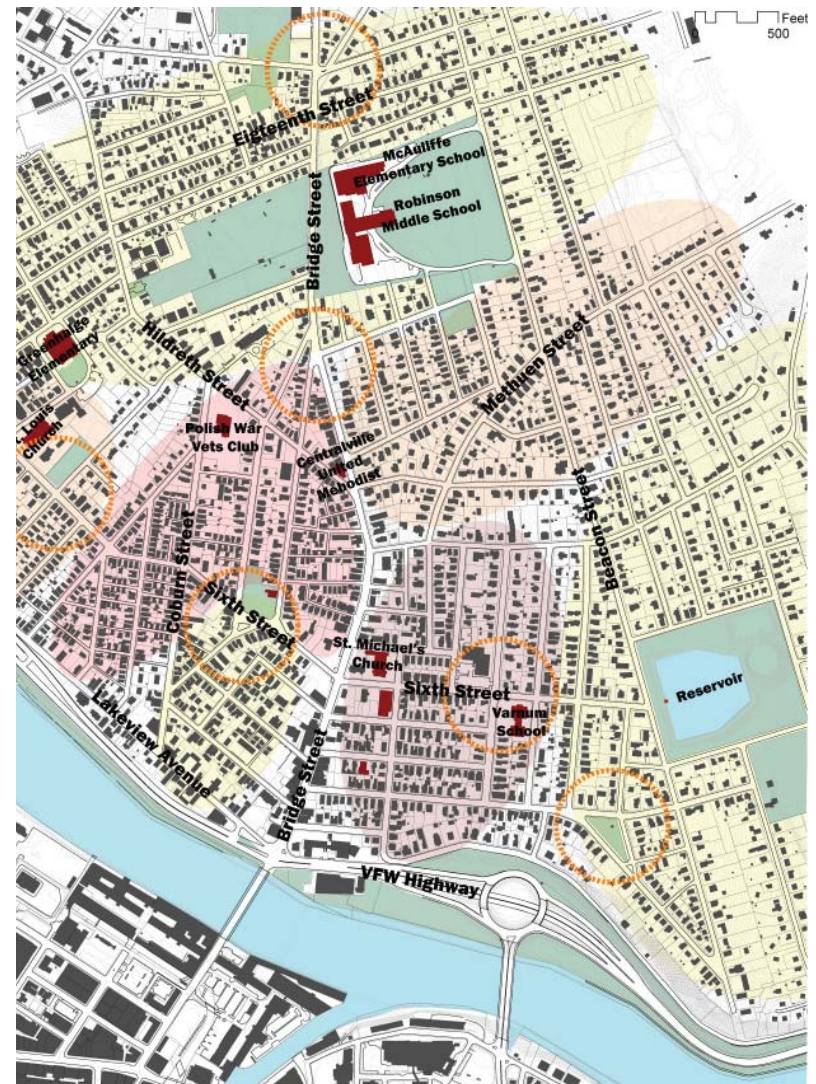

Figure 3:
Centralville Character Districts
Base Map Source: Lowell Division of Planning and Development

Overlay Districts

Where districts need more definition, we recommend considering an Overlay District that would ensure a more comprehensive approach toward issues like traffic and use regulations. An Overlay District would connect neighborhoods that span across zoning boundaries and allow for more sensitive, place-based regulations. Two areas particularly suited to overlay districts are the Bridge Street Corridor and the Reservoir District.

The Overlay District concept can also protect historic character in neighborhoods like the Fulton Street Area Cottages and Christian Hill. Although these neighborhoods do not currently have enough historic fabric to qualify as nationally-recognized “historic districts”, they present an opportunity for a local Overlay District that could be overseen by a Citizen Design Review Board.

In addition, Centralville could consider an Artist Overlay District in order to provide live-work artist lofts and apartments to artists outside downtown Lowell. The increase in property values in downtown Lowell may create an opportunity for Centralville to attract artists to its array of housing opportunities. This opportunity could be maximized by an Artist Overlay District, which may also encourage the opening of artist-oriented stores and galleries along Bridge Street. It is important to recognize that these Overlay Districts would maintain current as-of-right zoning.



Figure 4:
1907-2005 Overlay
Source: Sanborn Maps

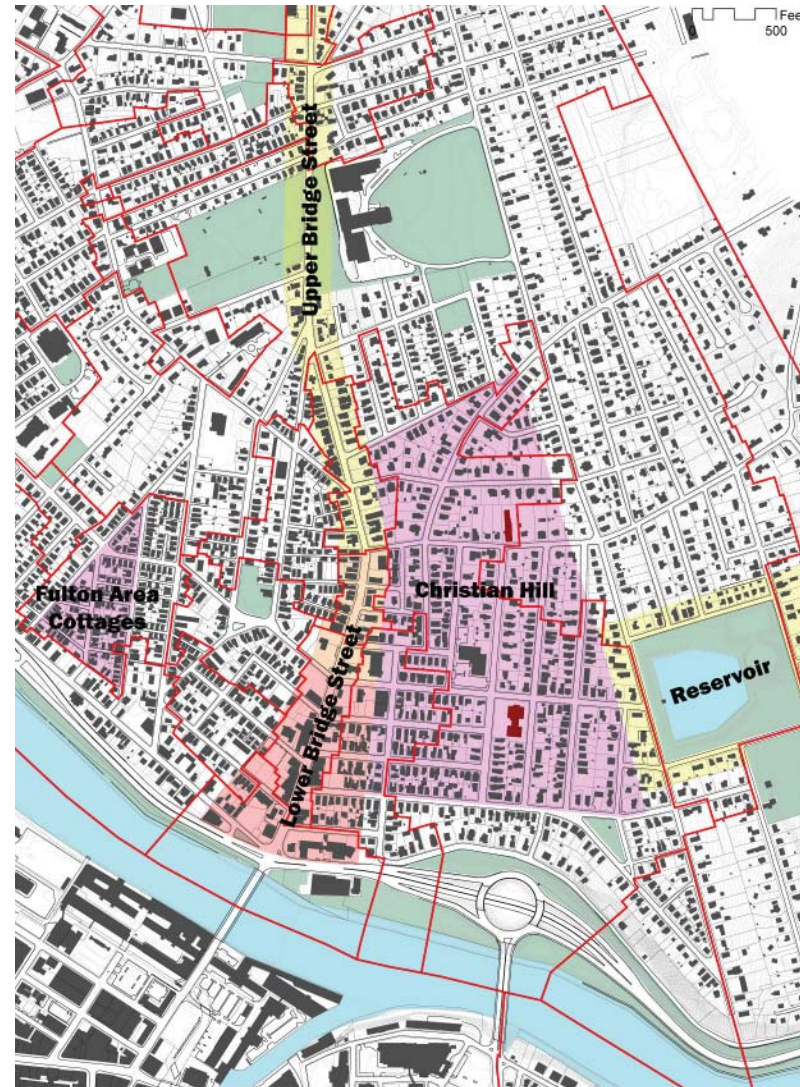

Figure 5:
Proposed Overlay Districts
Base Map Source: Lowell Division of Planning and Development



Figure 6:
Continuity along Upper Bridge Street

Figure 7:
Existing Zoning Districts on Upper Bridge Street

Upper Bridge Street

One example of a possible Overlay District is the Upper Bridge Street area, running from Seventh Street to Billings Street. Traffic along Bridge Street severely impacts connectivity between the east and west sides, and it is often unsafe for pedestrians to cross the street. In addition there are numerous changes in building types, permitted uses, and zoning districts in a short distance. Most of the structures are residential, transitioning from single family to multi-family closer to Lower Bridge Street, but they often have very different setback and FAR requirements, depending upon their particular zoning. A Bridge Street overlay district would provide a greater sense of continuity to this pathway, and would treat Bridge Street as a whole, rather than a series of parts. Recommendations for this Overlay District include the following:

- A single district on both sides of Bridge Street
- Transition between zoning districts is located in the center of and along the length of Bridge Street
- Traffic calming along Bridge Street by using bump-outs, limiting parking on Bridge Street to one side, and creating a Gateway (as mentioned in the Nodes Section) that welcomes drivers to the Centralville neighborhood
- Sidewalk widening with proper tree planting, landscaping and paving
- Reinforcement and enhancement of existing nodes along Bridge Street

Reservoir District

The Reservoir at the top of Christian Hill is another unique and important resource for Centralville. It also offers terrific views of Centralville and Lowell. This open space is a wonderful place for recreation, although we believe that a few physical changes may increase the recreational potential of the Reservoir park, the largest open space in the community of Centralville. We recommend several steps to preserve and enhance this asset.

- Build up connections to the neighborhood through Sixth Street
- Renovate gate house and revision this structure as an entranceway to the Reservoir park
- Set up bulletins for information exchange, introduction, and water resource conservation education
- Increase accessibility
- Replace chain-link fence with shorter wrought iron fence to increase visibility and make the park more inviting to visitors
- Enhance jogging/walking track pathway
- Enhance the physical safety
- Repair/replace chain link fence at shore-line
- Set up more “no swimming” signs at shore-line
- Improve the physical appearance and visibility
- Remove litter
- Repair or replace outdoor furniture
- Establish tree planting/ bird watching/picnic area
- Consider verlay district to maintain continuity between the adjacent housing properties and the park
- Mobilize volunteer residential group to organize recreational and community-based activities.



Figure 8:
The Reservoir is an amenity for Centralville.



Figure 9:
Existing Zoning Districts around the Reservoir.

Neighborhood Nodes

Within the neighborhood fabric, we observed several nodes, or places of significance. A node is defined as a place where roads or paths converge, where people congregate for work or play, or where there are landmarks or other buildings which give the immediate surroundings a sense of place. Some examples of nodes are Mt. Vernon Square, Varnum School Node, Moulton Square, and the Gateway Node at Bridge, Jewett and Hampshire Streets. We recommend that the Neighborhood Planner evaluate these nodes to determine if they are, in fact, significant and if there are other nodes worth identifying.

We can recommend several incremental improvements that will enhance these nodes and mark them as significant places. These small public investments should be the seeds to attract additional private investment in the future.

- Tree, flower and grass planting
- Sidewalk widening
- Removal of fences or other barriers when appropriate
- Street furniture, such as benches
- Traffic calming
- Building improvements
- Overlay districts that tighten the neighborhood fabric and support local businesses where appropriate

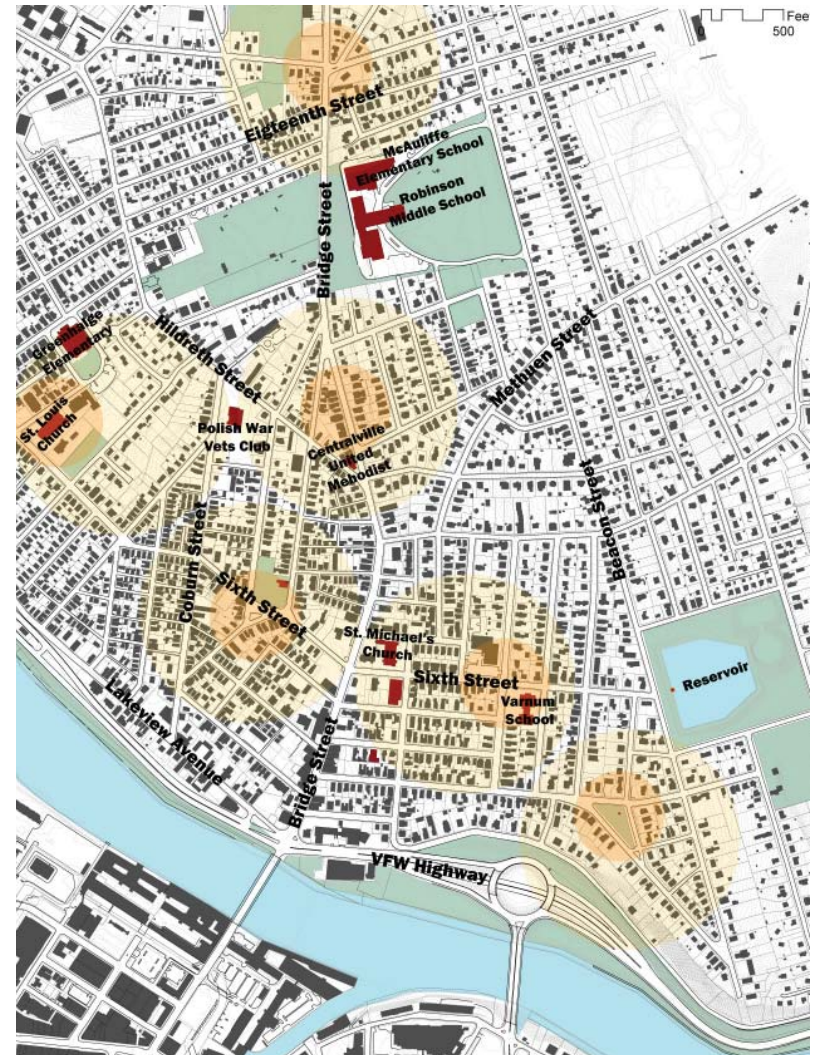

Figure 10:
Centralville Neighborhood Nodes

Figure 11:
Examples of Neighborhood Nodes

Varnum School Node

In particular we focus on two nodes: Varnum School and the Gateway. Both stand to gain tremendously from a few strategic public investments. Not only does the Varnum School node boast an impressive school building which is an historic landmark, but it also possesses the J&M Variety Store, the Lowell Healthcare Center, a middle school, church and numerous kinds of housing. At the corner of Sixth and Myrtle Streets we recommend the following improvements. (See Figure)

- Relocation of Varnum School’s playground fence at the corner to make way for grass, plants, and two benches.
- Bump-outs at the corners of Myrtle and Sixth Streets, as well as Beech and Sixth Streets, to mark the school as an important place and to slow traffic down around the school.
- A small path leading to benches under the pine trees alongside the Healthcare Center, allowing patients and their families to watch school children at play across the street.
- A zoning text amendment. Currently, Section 4.5.8. of the Zoning Code reads: “No nonconforming use shall, if changed to a conforming use, revert to a nonconforming use.” We recommend additional language following this sentence, that



Figure 12: Proposed Improvements for Varnum School Node

reads “...except by special permit for uses under 2,500 square feet, restricted to neighborhood retail use and excluding garages, auto services, or drive-through establishments.” Recognizing the important conveniences that J&M Variety Store offers within the immediate neighborhood, we think it is important to protect the existence of this and similar retail establishments, especially when these retail operations are abandoned and subsequently lose their non-conforming use status. Because these “intra-neighborhood businesses” are pedestrian-oriented and do not require significant parking, the standard parking regulations should be waived. Instead, such parking requirements should be limited to as many on-street parking spaces as are available in front of the establishment.

- Additional line item in the chart on page 92 of the Zoning under Section 12.4 “Retail, Restaurant and Consumer Service Uses”: “a. Retail operation with 2,500 square feet or less of gross floor area per establishment” as follows:

	SSF	SMP	SMU	RR	TSF	TTF	TMF	TMU	NH	USF	UMF	UMU	DMU	HRC	INST	OP	LI	GI
a. Retail Operation w/2,500 SF or less	N	N	Y	Y	SP	SP	SP	Y	Y	N	N	Y	Y	Y	Y	Y	SP	SP

This change will allow for the possibility of small, neighborhood and pedestrian-oriented retail that cater to a dense neighborhood core market to develop in zones where they are currently not permitted. Since the community acknowledges this type of retail establishment as an asset, we would like to remove any zoning barriers to developers who would like to open new pedestrian retail stores.



Figure 13: Opportunities at Varnum School Node

Gateway Node

In addition, we recommend several measures to improve the Gateway node, establishing this point as an entryway into the community for those traveling south on Bridge Street. Many of these recommendations build upon the recent work the city has done at and around this intersection.

Our Gateway node recommendations include:

- Install signage for Centralville and Lower Bridge Street business district.
- Impose traffic calming and safety enhancement.
- Limit traffic to two lanes along Bridge Street, and parking to one side.
- Improve connection of Jewett Street and Hampshire Street with Bridge Street by making these intersections more perpendicular.
- Enhance pedestrian environment with landscaping and sidewalk improvements.
- Build transit-related amenities, such as a bus shelter.



Figure 14: The intersection of Hampshire Street and Jewett Street at Bridge Street

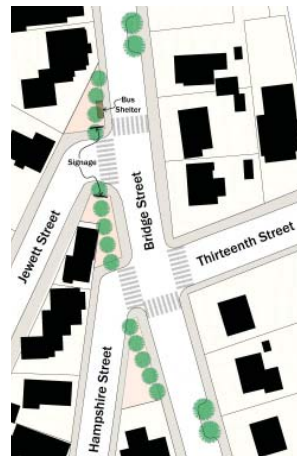

Figure 15: Proposed Improvements for the Gateway Node

Transfer of Development Rights

Another tool to preserve and enhance what is valuable in Centralville is the concept of Transfer of Development Rights (TDR). This is a voluntary, incentive-based process for preserving a community resource for public benefit. A TDR specifies a donor site, which transfers certain development rights to a receiver site. If enacted, a TDR should be used in limited and controlled application to address issues such as open space requirements and parking requirements, and we recommend considering a TDR to protect “vulnerable” sites from over-development. An example of a vulnerable site is the Polish War Veterans Club, a 10,000 square foot building situated on a 99,000 square foot site with an allowable FAR of 1 (Zone: TSF). We envision this remaining a community facility with recreational open space, day care (for children and seniors), performing arts, and other community uses. If developed to its full “zoning potential”, this property would most likely not remain a community center, since the lot is very large and can accommodate a much larger, multi-story commercial or residential facility. To keep the site as a location for a community-oriented facility, we recommend the following:

- TDR option in current zoning
- Definitions of transferable rights (open space, parking, etc.)
- Locations for donor sites (residential districts) and receiver sites (neighborhood business or mixed-use districts)
- Maximums for transfer

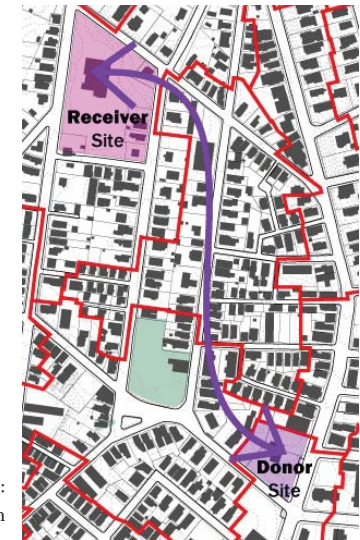

Figure 16: Transfer of Development Rights Illustration

Multi-family Housing

In recent years, prior to the 2004 zoning revisions, developers constructed several townhome complexes that wrinkled the historic fabric of the Centralville neighborhood. These developments suffer from blank walls, ground floor garages and architecture that is inconsistent with neighboring housing. The protests of CNAG and others resulted in the thoughtful zoning revisions of 2004, which prohibit multifamily development of any kind in many parts of Centralville; where the zoning allows multifamily, developments must conform to strict rules about density and form. However, many neighborhoods in Centralville contain non-conforming multifamily buildings that can act as examples of context-sensitive, appropriate multifamily design. Many of these are single-family home conversions that have maintained the historic facade of the building and tucked the parking units alongside the house, rather than in front or along the street-facing.

With these conversions in mind, we recommend that Centralville amend its multi-family zoning to encourage thoughtful conversion of single-family homes by small-scale developers. A zoning text amendment could add incentives for these developers, which encourage the preservation rather than the tear-down of historic homes. This amendment could include:

- density bonuses
- parking requirement waivers
- “FastTrack” permitting

Again, a Citizen Design Review Board could play an important role in implementing these zoning changes and shaping the future of multifamily development in Centralville.



Figure 17: Examples of Multi-Family Housing in Centralville

Recommendations and Implementation

This chapter suggests various interventions that will enhance the Centralville neighborhood. We have organized these interventions into three specific recommendations: (1) formulate zoning text and map amendments; (2) create a Citizen Design Review Board; and (3) create a Centralville Citizen Action Committee. These recommendations address the desire to protect what works best about Centerville and to implement strategies that will preserve and enhance the fabric and character of the neighborhood.

Recommendation 1: Amend Zoning Text and Maps

- *Overlay or Character Districts* - a map amendment that will promote compatible infill development within neighborhoods that may transcend the boundaries of current zoning
- *Transfer of Development Rights* - a tool that can allow greater context-sensitivity in redevelopment by “swapping” locations of required elements such as parking and open space
- *Incentives for developers who “do it right”* - incentives that reward developers who design new and/or infill development that is compatible with its surroundings
- Text Amendments to help maintain current non-conforming retail uses at nodes- these amendments permit small neighborhood retail stores and allow for some flexibility in redeveloping existing non-conforming uses

These amendments support the character of Centralville in a variety of ways and allow greater flexibility for developers who want to maintain this character. Character and Overlay Districts complement the current zoning, while the transfer of development rights ensures that vulnerable sites, like the Polish American War Veterans Club, will not suffer in the future from overdevelopment. Incentives like density bonuses, parking requirement waivers, and “fast track” permitting encourage more thoughtful design that is mindful of the surrounding context. Preservation and rehabilitation of older homes may take more time and expense than tearing down and rebuilding a multi-family unit, and these incentives compensate developers for this extra effort. Lastly, residents of Centralville recognize the uniqueness and importance of neighborhood-oriented, pedestrian-accessible retail stores. The last amendment above ensures that even if store ownership changes hands, retail use will still be permitted.

Recommendation 2: Establish a Citizen Design Review Board

With its well-maintained stock of historic homes and buildings, Centralville needs a Citizen Design Review Board that will work with developers and the City of Lowell to maintain this neighborhood’s historic fabric. The Citizen Design Review Board will focus less on the details of design and construction than on issues of massing, use, and frontage, to ensure that new developments respect the existing neighborhood scale. Often, these types of boards are comprised of citizens, planners, and designers who want to encourage thoughtful development while respecting existing structures and their owners.

Recommendation 3: Centralville Citizen Action Committee (CCAC)

Two neighborhood groups have taken active roles in local politics, organizing and events; the Centralville Neighborhood Partnership (CNP), and the Centralville Neighborhood Action Group (CNAG)

Centralville Neighborhood Partnership

CNP is the older of the two neighborhood groups. Although this group has worked on a broad scope of issues, it currently focuses its efforts on historic preservation. The membership of CNP resides primarily in the Christian Hill area of Centralville, and preservation efforts have concentrated on the Hill.

Centralville Neighborhood Action Group

CNAG is the younger of the two organizations in Centralville and was founded by former members of the CNP. These founders wanted to diversify the geographic and contextual focus of the CNP. The issues that CNAG addresses today include crime, health, neighborhood beautification, Bridge Street improvements, and support for local merchants.

A new organization would combine the best parts of existing Centralville neighborhood groups into a cohesive community organization that would speak for all of Centralville, including the residents on both sides of Bridge Street and the commercial interests of Bridge Street itself. An example of comparable groups are Boston’s Citizen Action Committees. These CACs each represent a specific district, and membership is appointed and tasked with providing feedback to the city in the zoning approval process.

This group would achieve the following ends:

- Formalization of “community voice” to inform the decisions made by the City of Lowell (especially the Planning and Zoning Board and the Planning and Develop-

ment Department);

- Representation of a greater diversity of age, ethnicity and interests, reflective of Centralville's residential and commercial population;
- Cultivation of a new leadership for the next generation.

At a community meeting on December 6th, membership from CNAG and CNP as well as other attendees were very much in support of the formation of the CCAC. There was specific concern expressed that the CCAC be issued "clout" so that the group would have direct influence on the decisions and recommendations of the Lowell Planning and Zoning Board and the Planning and Development Department.

To implement an organization like the CCAC, the Lowell planning board can integrate the CCAC into the city's zoning code. The CCAC would meet once a month (or as needed) to review development and design proposals, redevelopment plans and programs, development and loan agreements, and other Centralville-related development policies and programs. Members would publish a quarterly newsletter to keep Centralville advised of issues and meeting schedules. The CCAC would sponsor various community meetings and workshops to seek public input on local matters. The CCAC would be aided by City of Lowell staff support.

This proposed Centralville Community Action Committee would ensure that residents have a unified "voice at the table", which represents a wider range of experiences than currently CNAG and CNP alone can express. To do this, membership would be 1) appointed and 2) spread geographically among residents, business owners, and other stakeholders.



SIXTH STREET



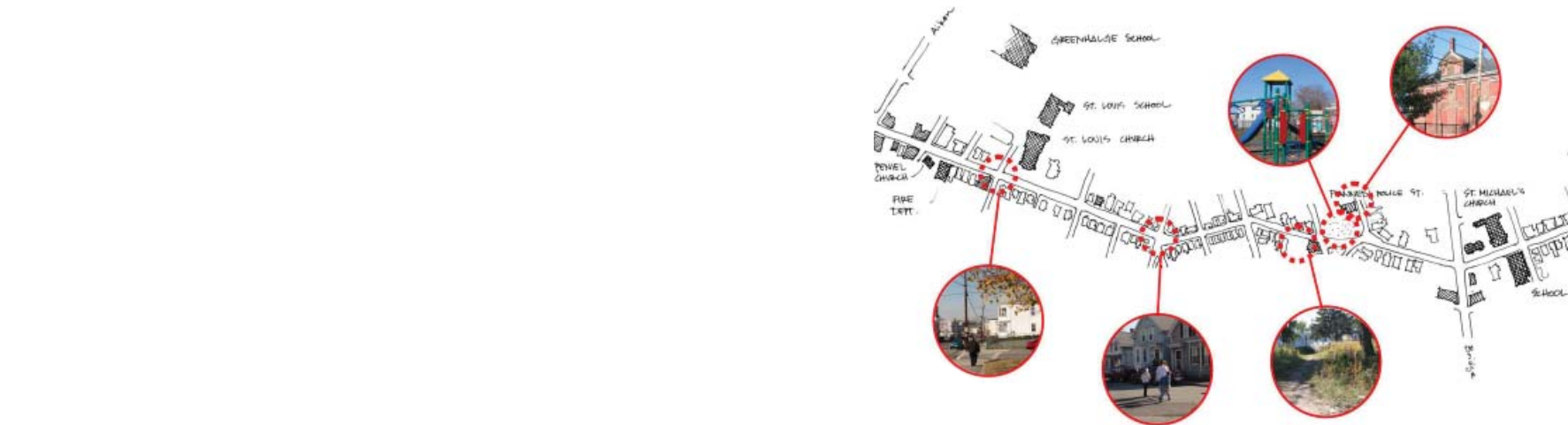

INTERVENTIONS ALONG SIXTH AND WEST SIXTH STREETS

We chose to take a closer look at Sixth and West Sixth Streets for several reasons. First, these streets serve as a connecting thread between the eastern Christian Hill section of Centralville, the Aiken Square area to the west, and beyond. While most other streets “T” into Bridge Street, requiring a traveler to make a jog to connect to the other side, Sixth and West Sixth Streets connect straight across Bridge Street.

In addition to being an east-west connector, Sixth and West Sixth Streets have along them several important schools, churches, neighborhood stores, open spaces, and nodes as identified by the preceding section of this report. For these reasons, many people daily travel this corridor.

Finally, Sixth and West Sixth Streets merit further attention because this route has the feel of an arterial street, though it is actually quite residential in nature: residences make up the majority of street frontage along the streets. These streets therefore have the potential to become more attractive, safe, and inviting.

We have devoted our attention to street safety and beautification and individual parcels that have development potential.



Figure 1: intersection of Boisvert and West Sixth Streets today



Figure 2: potential future appearance of intersection of Boisvert and West Sixth Streets

Street Safety and Beautification

West Sixth Street and its eastern counterpart, Sixth Street, have the potential to be beautiful residential streets. At the moment, however, large sections appear to be used merely as an urban artery. Residents perceive that cars speed past children and front porches while weaving their way from Aiken Avenue to Bridge Street. However, the actual volume of traffic is modest. We believe that there are simple means with which the city can progressively shift this perception and make the street a more pleasant and safer place for residents, pedestrians, children and those just passing through.

General Investments

Providing a basic consistent streetscape is an important mechanism for communicating that Sixth and West Sixth Streets are a significant residential street and not simply a thoroughfare for through traffic. Listed below, in order of priority, are what we consider to be the most important elements for achieving this goal. Included with each element is the rationale behind its importance and a rough estimate of its cost.

1. Street Trees

Currently, very few trees line Sixth and West Sixth Streets. There are two trees across from the St. Louis school, and their presence, even in the late fall, illustrates their addition to the streetscape (see Figure 3). The addition of trees has the ability to calm traffic, provide beauty, and buffer homes and pedestrians from the street. Street trees are also a recommended addition to Sixth Street at the approach to the reservoir. These trees would provide a visual clue that a significant open space lies ahead.

A frequent impediment to the addition of street trees is utility lines. With that in mind their placement will have to be judicious.

Cost per Tree:	\$650 to 850
Trees needed:	140 (every 20 feet of wide sidewalk without utilities)
Total Cost:	\$91,000 to \$119,000 dollars

2. Parking Stripes

At 40 feet, West Sixth Street to the west of Stanley Street is wider than necessary. Although this does have advantages for various public services, it provides a tremendous incentive to drive at excessive speeds. In addition, the street has



Figure 3: images from Centralville: street trees, parking stripe, crosswalk, potential location for a bumpout, utility wires to be undergrounded.

few parked cars, further increasing the tendency to speed. One simple way to narrow the perceived size of the street is to add parking stripes (painted white lines) that delineate the driving and parking lanes. Such a treatment also clarifies where street parking is available and can help avoid parking on sidewalks.

Cost per Linear Foot: \$0.65
 Linear Feet: 7,000 feet
 Total Cost: \$4,550

3. *Crosswalks*

Every intersection on Sixth and West Sixth Street should include a crosswalk that crosses Sixth and West Sixth Street. This is a simple low cost method for signaling activity to vehicles and gives priority to pedestrians. Textured crosswalks, such as those in Moulton Square, are especially beneficial.

Cost per Crosswalk: \$300 to \$900
 Crosswalks Needed: 24 (6 four-way intersections)
 Total Cost: \$7,200 to \$21,600 dollars

4. *Bump-outs*

Bump-outs are portions of the sidewalk that “bump out” into the street at crossings. They effectively narrow the street, shorten the crossing for pedestrians, and clearly demarcate legal parallel parking spaces. Ideally they should complement every Sixth Street crosswalk.

Cost per Bump-out: \$2,500 to \$4,000
 Bumpouts: 24 (6 four-way intersections)
 Total Cost: \$60,000 – \$96,000

5. *Utility Under-grounding*

Removing utility poles and burying their wires is the ultimate in streetscape beautification. Not only do they free up the sky of crisscrossing wires, they also provide room for the complementary placement of trees on either side of the street. The cost of under-grounding is likely to be the most expensive design intervention. Despite this, the opportunity should be considered in coordination with major street upgrades.

Cost per Lot: \$5,000 to \$7,000
 Lots: 133
 Total Cost: \$665,000 to \$931,000 dollars (plus cost of replacing light posts)

Specific Investments

We believe that two key places on West Sixth Street could significantly benefit from immediate design interventions. These locations were chosen because they illustrate the most potential to both calm traffic and improve safety for pedestrians on West Sixth Street. Together with Moulton Square, these high quality urban spaces provide for a succession of “moments” that give the driver reason to pause, observe his or her environment, and be reminded of the surrounding residential neighborhood.

1. West Sixth, Stanley and West Streets

The intersection of West Sixth, Stanley and West Streets is a confusing one (see Figure 6). As all three streets simultaneously converge, West Sixth begins a 45-degree turn while narrowing from 40 feet to 28 feet wide. From the perspective of the driver, it is unclear which lane is where and what cars have the right of way. For the pedestrian, the intersection is dominated by pavement and is without a crosswalk.

The proposed design, which is illustrated on the facing page (see Figure 7), minimizes the crossing distance for pedestrians, maintains existing parking, clarifies the intersection for vehicular traffic and provides for trees and benches.

2. West Sixth and Boisvert Streets

While during off-peak hours West Sixth Street’s intersection with Boisvert Street is quiet, over 1,000 students a day pass through this intersection on their way to and from the St. Louis and Greenhalge schools (see Figure 8). Unfortunately, this is also a flat and straight section of West Sixth Street where cars often reach their highest speeds. With that in mind, we believe that the intersection deserves a stop sign and other basic streetscape investments. The recommended plan is illustrated on the facing page (see Figure 9).



top: Figure 4: current conditions at intersection of West Sixth, Stanley and West Streets
bottom: Figure 5: current conditions at intersection of West Sixth and Boisvert Streets

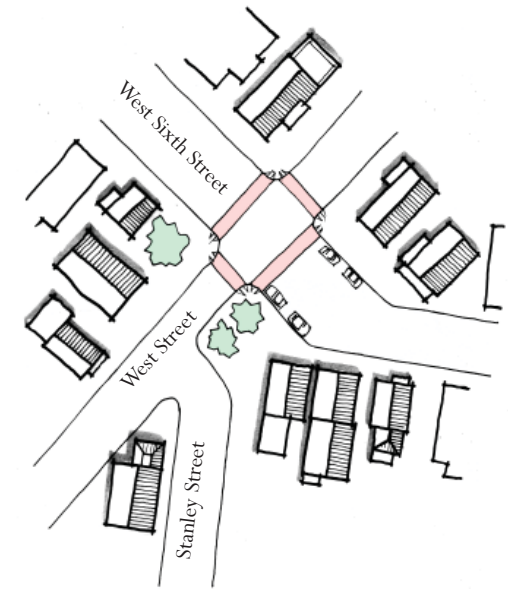

Figures 6 and 7: current and recommended configuration of West Sixth, Stanley and West Streets

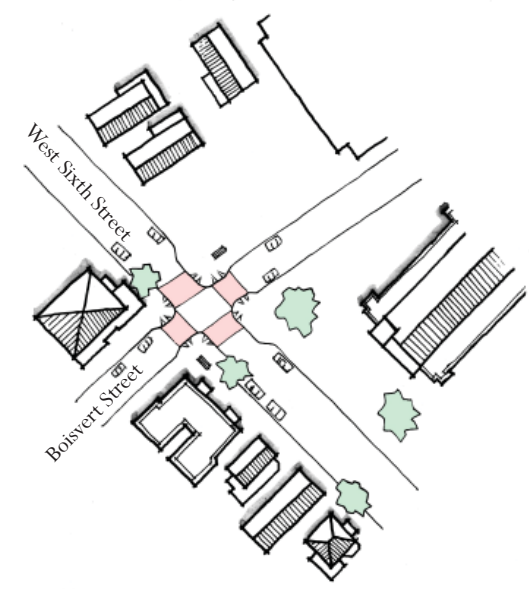
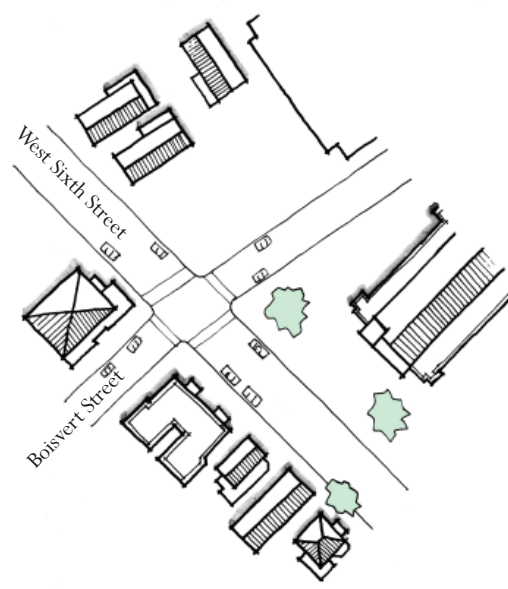

Figures 8 and 9: current and recommended configuration of West Sixth and Boisvert Streets

Guiding Future Development

Vacant Parcel at 84 West Sixth Street

The parcel at 84 West Sixth Street presents a unique opportunity to positively affect the built environment and image of this street. This is currently the only vacant parcel along West Sixth Street, one of the primary interior streets of the neighborhood, and is located just steps from the important node that is Moulton Square.

The property comprises about 10,750 square feet (approximately a quarter of an acre) and is zoned Traditional Multi-Family (TMF). Current zoning would allow for up to four residential units on the parcel. An indication of the market potential for residential development on this parcel can be drawn from the development of four condominiums units on an adjacent parcel, which sold for \$220,000 each.

Recommendations:

Any or all of the following recommendations should be followed in redeveloping the lot at 84 West Sixth Street:

1. The city should initiate tax taxing procedures

Records indicate that the owner of 84 West Sixth Street owes the city more than \$52,000 for a demolition lien, unpaid taxes and outstanding water bills. Property taxes have not been paid since 2001. We assume that the property owner has done nothing to promote development of the site and it is likely that without further city intervention, this parcel will likely continue to sit vacant, blighting the surrounding neighborhood by signaling neglect and disinvestment in the community.

We believe the city should initiate the process of a tax taking with the intention of either motivating the existing owner to sell the property to someone with an interest in developing it or taking possession of the property. From our standpoint, this process offers the guarantee of a desired outcome sometime in the near future, as opposed to the uncertainties inherent in the status quo.

After following notice procedures spelled out by statute, the city could formally “take” the property, leaving the owner of the property six months to redeem the property by paying off the debts owed on the property. Most likely, the property



Figure 10: 84 West Sixth Street

would only be redeemed if accompanied by a transfer by the current owner of the property to someone else who has an interest in developing the site.

In the event that the owner does not elect to exercise his redemption rights within six months, the city would then be able to follow foreclosure procedures, which would put it in a position to recover the debts owed by the current owner by selling the property to an interested developer. Currently the property is assessed at \$112,000 and given its size and development potential, it is almost certain that the city could sell the property for more than \$52,000, and thereby be able to cover administrative expenses and even retain some surplus for the city treasury.

2. This site should be utilized for compatible infill development

We think some form of development on the site is preferable to the three basic options under which no new buildings would be constructed. The first such option is the status quo, which as stated above we feel is undesirable. The second option would be to convert the site into a park. Given the proximity of this parcel to Monsignor Keenan Playground, we do not believe a park here would be well-utilized or is a good use of city funds.



Figure 11: 84 West Sixth Street looking toward Moulton Square and Bridge Street

The third option would be to convert the parcel into a city-owned parking lot. While we recognize that this would be of assistance in dealing with some of the perceived parking issues in the neighborhood, we do not recommend this course of action. The parking lot would only improve the parking convenience of a few residents living within close proximity to the lot—an area which already has access to a public parking lot adjacent to the basketball court at Monsignor Keegan Playground and parking around Moulton Square. We think under the circumstances, the dedication of a quarter acre site to a parking lot would be an excessive response and that from an aesthetic point of a view, such a parking lot in the midst of residential neighborhood would only be marginally better than the current conditions, while adding to maintenance costs for the city.

3. Careful attention in new development should be paid to contextual design:

Recent development in Centralville indicates that there are potential problems in incorporating new development into the existing fabric of the neighborhood. We feel that there are two primary issues with respect to contextual design on this site: 1) setbacks and 2) orientation toward the street. While the recent amendments to the zoning code has done much to address both these concerns, if the city acquires control of the property, it should ensure that the building design provides the maximum benefit to the neighborhood and is consistent with the existing fabric.



Figure 12: typology of building possibly suitable for infill at 84 West Sixth Street

4. Mixed Use Possibilities:

In our analysis, we considered the possibility of a mixed-use development at 84 West Sixth Street, consisting of a small commercial space on the ground floor with residential units above. Adjacent to 84 West Sixth Street, at the corner of Jewett Street, is a mixed-use building containing dwelling units, a driver's education business, and a convenience store. While the commercial uses are nonconforming, these businesses appear to be doing well and there is no sign that commercial activity will cease on this corner, where it has existed since at least 1897 (Source: Sanborn Fire Insurance Maps).

Allowing certain commercial uses at 84 West Sixth, such as a neighborhood coffee shop, sandwich shop, or crafts store, could further enhance Moulton Square as a gathering place for the community. A commercial use on the ground floor might also facilitate a building design with the kind of setback and direct orientation toward the street that we think would fit best with the existing fabric of the neighborhood. (i.e. minimal setback and entrances facing the street). An example of the kind of structure we think could work on this site is shown in Figure 12.

All parking demands generated by such a use could and should be accommodated on site. In light of the untested market for commercial space in this area and



Figure 13: currently, the playground is completely fenced off from West Sixth Street

concern voiced by some members of the community, we feel that this mixed-use potential needs further study. It would require relief from existing zoning, which bans all commercial uses in the area. We recognize that economic or neighborhood concerns might dictate that a strictly residential development is the best course. However, the convenience and intimacy of neighborhood retail is one of Centralville's assets, and something that makes the neighborhood unique from other newer neighborhoods. We urge the community to consider how a mixed-use environment currently enhances and could further enhance their neighborhood.

5. Condominium Parking:

Though we do not suggest dedicating the site entirely to public parking, an innovative idea for the site is to set aside some parking spaces on the site to a condominium parking program whereby the spaces could be acquired by neighborhood residents for their private use. If a commercial use were placed on the site that only operated during the day, the cost of maintaining the parking spaces and the use of the spaces themselves could be shared between the resident purchaser and the business owner. Any such arrangement would provide additional parking spaces for the neighborhood.

Monsignor Keenan Playground

There are two primary issues to address with respect to Monsignor Keenan Playground. The first is the litter problem, second is the visibility and accessibility of the playground. The amount of litter in the playground detracts from the quality of the experience there and sends negative signals about the neighborhood around it. While it may be impossible to avoid all litter, we think more can be done to keep this area clean.

Recommendations:

1. The city should install more trash receptacles in the interior of the playground.
Currently, the only trash receptacles are located at the edges of the playground, near the entrances.
2. Community groups should organize regular community cleanup days.
Given the small size of the playground, we think this could be accomplished in a reasonably short period of time and in the process build greater ties and pride in the community.



Figure 14: trash receptacles are currently located only at the entrances to the playground

3. Improve the visibility and accessibility of the playground.

This is a longer-term recommendation, which could be accomplished by installing a lower fence and possibly moving the location of the gates to make the playground more prominent and noticeable. We feel that a fence design such as that shown in Figure 16, could accomplish these goals while not aggravating the safety concerns we heard from community members.



Figure 16: a lower, wrought iron fence could help enhance the appearance of Msgr. Keenan Playground, make it more inviting, without detracting from its safety.



Figure 15: the former Parks and Recreation building on Hampshire Street

Former Parks and Recreation Site at 10 Hampshire Street

Opportunity:

Because the City of Lowell owns this property, a tremendous opportunity exists to continue the work already done to improve the appearance, character and perception of the Moulton Square neighborhood. We present here three alternative uses that we believe are appropriate for the site.

History:

The existing building is one of several late 19th century brick structures originally built on the site, the majority of which were demolished in 2001. The buildings were used by the City of Lowell’s Water Department and more recently the Parks and Recreation Department. In 2001, the City Council directed the Division of Planning and Development to demolish the run-down, vacant building behind the playground. Based on a series of public meetings with the neighborhood, it was decided that the city redevelop the remaining portion of the building for public uses. The Lowell Police Department procured an architect to study the redevelopment of the building at 10 Hampshire Street for a neighborhood precinct and meeting space.



Figure 17: the northern facade of the former Parks and Recreation building on Hampshire Street
Current Conditions:

The building currently sits in a state of disrepair, with boarded windows, piles of fill, timber and other materials in the parking area, and partially surrounded by a 10-foot-high fence. A corner of the building appears to be in the midst of being torn down. The building and surrounding site are unsightly and potentially a safety hazard, a condition which is made more prominent by its proximity to the playground and basketball court.

Community Concerns:

Abutters to the site have complained of noise and disruption from the adjacent basketball court and parking lot, especially in the middle of the night, even though the basketball court is supposed to be closed as of an hour past sunset. Nearby residents also mention concerns of drug activity in the area and reported to us that the convenience store at Moulton Square has been robbed at least twice in the last year. Parking is an ongoing concern for residents, who say that parking is lacking in the area, and when it snows that it is nearly impossible to park nearby.



Figure 18: from the parking lot on Jewett Street, orange barrels and piles of fill are visible in the parking lot.

Recommendations:

Alternative 1: Police Precinct and Community Space

Under this scenario, the city maintains ownership of the site and rehabilitates the current structure to house a police precinct and community space.

Given the concerns of the residents about inappropriate activity at the basketball courts and parking lot, as well as drug and crime concerns, an increased police presence would be warranted in this area. Conserving and improving the existing building should be a prerequisite for any development on the site, which this scenario does. In addition to helping reduce the likelihood of illicit activity in the area, use of this site as a police precinct and community space would not exacerbate the existing parking problems perceived by the adjacent residents, as all parking for the precinct would be accommodated on site. We also believe that the approximately \$700,000 cost estimate received by the Lowell Police Department (Source: November 2001 report by Cook Architects, Inc.) is reasonable for a project of this extent. Understandably, the Police Department has expressed financial concerns about a project of this magnitude. Alternative Three, below, addresses these concerns.

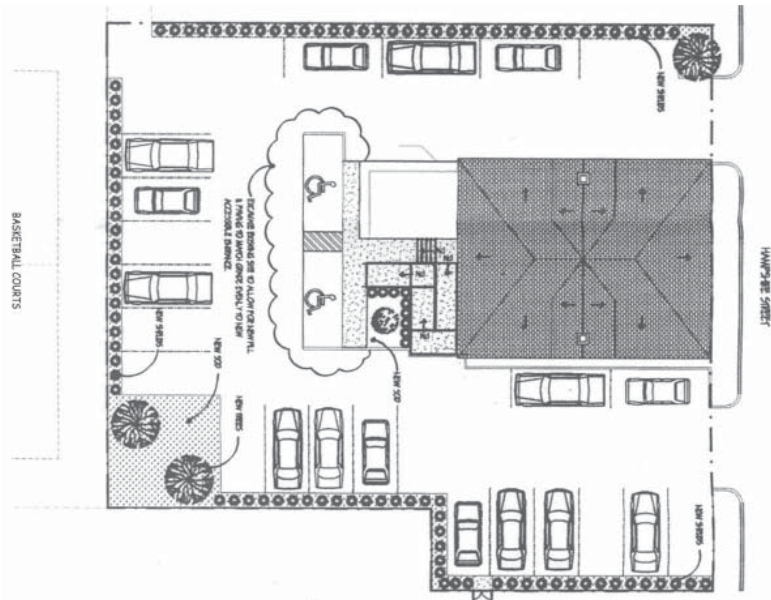

top: Figure 19: Msgr. Keenan Playground is immediately adjacent to 10 Hampshire Street
 bottom: Figure 20: the site plan from the November 2004 report to the LPD.

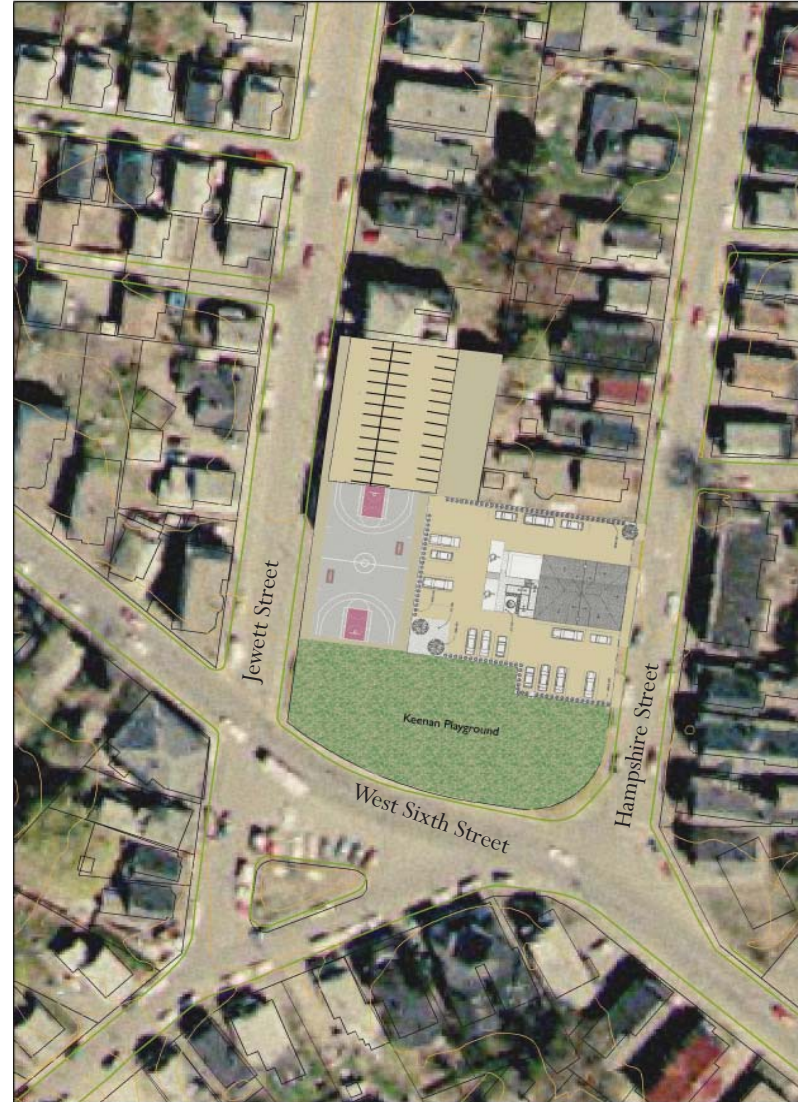

Figure 21: the relationship between the building at 10 Hampshire Street, Monsignor Keenan Playground, the basketball court and parking lot.



Figure 22: the Tenth Street School before renovation

Alternative 2: Residential

Under this scenario, the city issues a Request For Proposals (RFP) in order to divest themselves of the property, and the new owner rehabilitates the building into housing units according to the recommendations below.

In analyzing the site and its surroundings, we have determined additional residences would be appropriate here. Again, conserving and improving the existing building should be a prerequisite for any development on the site. The building could likely accommodate three or four one to two-bedroom units ranging from 800-1,200 square feet in size and common hallways.

In developing this proposal, the team looked to the recent renovation of the Tenth Street School, which exemplifies the rehabilitation of an historic structure (see Figures 22 and 23; Source: www.doorsopenlowell.org). The city sold the property to a private developer who undertook construction. Similar to the Tenth Street School renovation we suggest the use of the existing entrances and addition of porches and other appropriate detailing.

We anticipate concerns from abutters regarding parking availability, but believe that parking for the units could be accommodated on the site. The plans for the proposed police precinct indicate that as many as 22 parking spots could be located



Figure 23: the Tenth Street School after renovation, now contains two residential condos

on the site. This, however, does not allow for any yard space associated with the new housing units. We recommend providing no more than eight parking spaces on the site for the new residential units and devoting the remainder of the site to yard space associated with the new units. Alternatively, a portion of the parcel could be retained by the City of Lowell to provide parking spaces for other nearby residents or for Keenan Playground. We recommend replacing the existing fence around the site with a type of fencing more appropriate for a residential development (chain link fence could be appropriate, but only at a maximum height of four feet).

In sum, we recommend that the city include at least the following building and development requirements in an RFP:

1. Conservation of the existing structure.
2. Landscaping, including fencing, in character with residential development, and to serve as a buffer between the residential development and the adjacent public open spaces.
3. No more than 2 parking spaces per unit should be provided on the site, with the remainder used as yard space for the residents or retained by the city and used as public parking

building will be developed as a police precinct and rented to the City of Lowell Police Department for \$800 per month (or another predetermined amount).

Alternative 3: Police Precinct and Residential

Under this scenario, the city issues a Request For Proposals (RFP) in order to divest themselves of the property, and the new owner rehabilitates the building to into housing units and police precinct space according to the recommendations below, then rents a predetermined amount of space to the Lowell Police Department at a predetermined rent.

This third alternative is a hybrid of the first two: under this scenario, the building is renovated to include space for both a police precinct and some residential units. The police department currently rents 1,300 square feet of storefront space at 480 Bridge Street. The cost per year, as listed in Lowell's 2005 Master Plan, is \$12,000. We understand that the cost of renovation being considerably more than the existing cost of renting is a concern for the Police Department and the city. This hybrid alternative, therefore, allows the Police Department to gain new space in an area that could be well-served by an increased police presence, but the cost of renovating this older building does not fall to the city. In fact, the city gains revenue from the sale of the building, while the developer of the site has a predictable income stream for a portion of the development.

Within the building, we recommend that the police precinct be located on the first floor, to comprise 1,300 square feet in the southern portion of the building, that portion nearest the playground. This provides a transition between the public open space and the residences.

In sum, we recommend that the city include at least the following building and development requirements in an RFP:

1. Conservation of the existing structure.
2. Landscaping, including fencing, in character with residential development, and to serve as a buffer between the residential development and the adjacent public open spaces.
3. No more than 2 parking spaces per residential unit should be provided on the site, with the remainder used as yard space for the residents or retained by the city and used as public parking
4. 1,300 square feet (or another predetermined amount) of the first floor of the

BRIDGE STREET

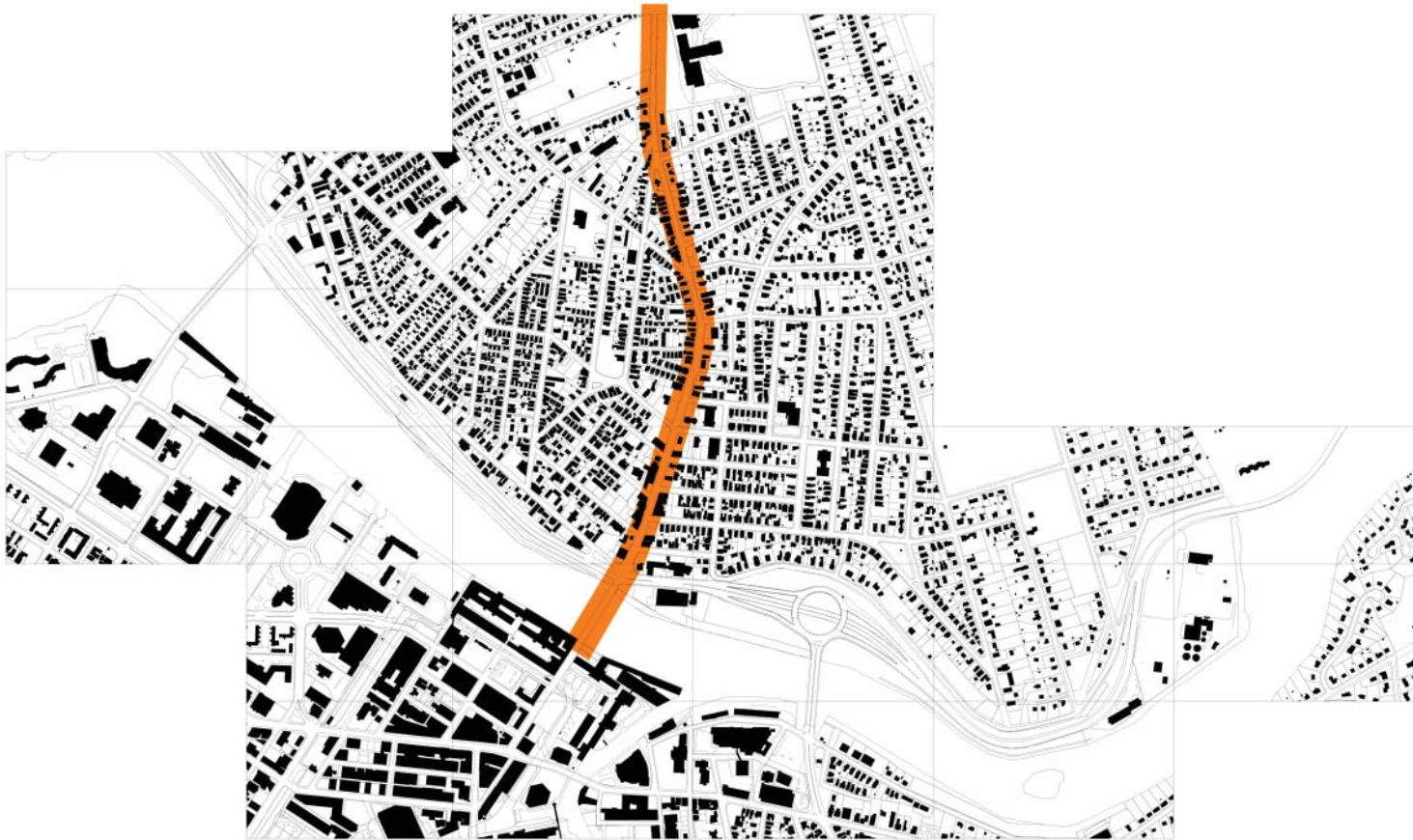

VISION FOR THE LOWER BRIDGE STREET COMMERCIAL DISTRICT

Lower Bridge Street (defined as the area between VFW and 7th Street) is a place for everyone in Centralville to work, shop, live, and play in a traditional New England main street setting. We visualize a vibrant, multicultural, and pedestrian-friendly Lower Bridge Street with a healthy mix of small businesses. In this section, we will discuss land use, parking and transportation, economic development, and a potential catalyst development.

Bridge Street Economic Development

The goals for economic development on Lower Bridge Street are an integral part of the vision for a vibrant, diverse, and economically sustainable place to operate and grow a business. Local business owners, the City of Lowell, and Centralville leaders communicated their ideas for achieving various economic development objectives through field visits, informal surveys, interviews, and public meetings. These ideas are the foundation of the economic development goals and recommendations detailed below for the Lower Bridge Street Commercial District (LBCD).

Goals:

- Strengthen businesses
- Preserve LBCD as an economically sustainable business district
- Attract a diverse mix of businesses
- Increase the variety and quality of products to meet needs of local residents

Lower Bridge Street (defined as the area between VFW and 7th Street) is a place for everyone in Centralville to work, shop, live, and play in a traditional New England main street setting. We visualize a vibrant, multicultural, and pedestrian-friendly Lower Bridge Street with a healthy mix of small businesses. In this section, we will discuss land use, parking and transportation, economic development, and a potential catalyst development.



Alternative vision of Bridge Street

Land Use

Lower Bridge Street is a dynamic, diverse, and flourishing New England main street; however, this main street character might come under increasing pressure with respect to future development. Comprehensive and forward-looking land-use regulation can serve the triple function of preserving this character, increasing the physical appeal of Lower Bridge Street to both visitors and residents, and facilitating other community planning agendas, such as economic development and housing.

The buildings, infrastructure, and activities of the street should be arranged and presented in a way that is connected, convenient, accessible, and pedestrian friendly; showcases business owners' investment in their small and diverse enterprises; makes the street attractive for residents and prospective residents of Centralville; and contributes to the street's traditional character. Specifically, land-use policies (e.g., building form, height, mass, street frontage, and lot-coverage) may be adjusted to facilitate the following objectives:

- Maintain the pedestrian-friendly scale and character of buildings on Lower Bridge Street;
- Better preserve and extend the Lower Bridge streetwall of compact storefronts and buildings with street-facing entrances;
- Encourage the development of mixed-use buildings, with ground floor retail and services and offices and residences on upper floors;
- Facilitate development of new buildings on Lower Bridge Street by improving parking and open space requirements; and
- Encourage contextually-consistent new development on Lower Bridge Street in areas that are currently or imminently under-used.

Current Conditions

About 17 of the 39 lots we surveyed on or immediately off Lower Bridge Street are either available for development, have owners who have indicated their interest in supporting further development on their sites, or might, at some point in the next few years, become available for development. Altogether, these lots comprise nearly a third of the total frontage along Bridge Street between VFW Parkway and 7th Street. Taken together, future development on these lots can transform

the character of Lower Bridge Street, for better or worse. Land-use guidelines governing the use and form of future buildings on these lots can ensure that these lots, and therefore the street as a whole, develops in a way that is consistent with the community's vision.

The stretch of Lower Bridge Street, from 2nd Street to between 6th and 7th Streets, is included in the Neighborhood Business Zone (NB). Selected key elements of Zone NB are summarized in the table below:

Floor Area Ratio	Maximum of 1.0
Lot Area	Minimum of 2,500 sq ft/dwelling unit and, for lots only containing residential buildings, a minimum lot size of 6,000 sq ft
Street Frontage	Minimum of 25 ft (40 ft for lots with residential)
Setback	Street-facing, to be consistent with other setbacks if the lots contain residences or 8 ft if the structure is non-residential
Yard	No minimum side yard; no minimum rear yard except for standalone residential buildings (20 ft)
Open Space	Minimum 250 sq ft per dwelling unit (unclear whether this applies to mixed-use buildings)
Height	Maximum of 40 ft and 3 stories (35 ft and 3 stores if building is exclusively residential)
Parking	Minimum of 2.2 spaces per multi-family residential unit (if 7 or more units, otherwise 2.0), 2 spaces per townhouse, 1 space per 900 sq ft of retail/service area, 1 space per 100 sq ft for restaurant and bar area, 1 space for 400 sq ft of commercial area

These provisions appear to have a number of limitations with respect to the stated objectives. Street frontage requirements do not require a continuous streetwall, although primary building entrances are required to face a street (not necessarily Bridge Street). There is no provision made for mixed-use projects where more than two dwelling units coexist in a single building with commercial uses, despite the fact that this type of building represents a substantial proportion of all buildings on Lower Bridge Street. Parking and open space requirements, which need to be addressed at the neighborhood level, are, instead required to be addressed only at the lot and building level. Finally, height requirements might limit the potential for profitable developments and appear to effectively prevent the development of new buildings that resemble some of the existing buildings identified by community members to be among the more ones attractive on the street.

A Future Development Path

By following the land-use-oriented development objectives laid out here, Lower Bridge Street will see the empty, available, and otherwise underutilized lots developed. The opportunities may be grouped into four zones:

- **Bridge and 6th** area lots, between 5th to 7th Streets, where the city has identified an opportunity to catalyze Lower Bridge Street redevelopment efforts with a landmark project at the northwest corner of 6th and Bridge, in addition to the prospect of other infill opportunities in the future;
- **Riverfront/Gateway**, between VFW Parkway and 3rd Street, where the available tavern building and Sunoco properties might provide an opportunity to develop a signature gateway to Lower Bridge Street seen by visitors coming up from Lowell, again in addition to other future infill properties;
- **Mid-Street**, between 4th and 5th Streets, where infill opportunities on low lot-coverage sites might eventually become available; and
- **Transition**, between the Lower Bridge Street commercial area and the Upper Bridge Street residential area, provides a lower intensity redevelopment opportunity focus on the the KFC/A&W site at the southwest corner of 8th Street.

At build-out, the currently fragmented Lower Bridge Street streetwall will be more or less continuous with retail, small office, and upper floor residential opportunities in mixed-use buildings, from VFW to 6th Streets and broken by gaps for landscaped parks/community gardens and appropriately placed driveways. Housing located above storefronts and offices will give the street additional vitality and offer attractive housing typologies (new apartments, smaller townhomes, artists' lofts) that might otherwise be rare in single-family-home dominated Centralville. Higher intensity pedestrian shopping/neighborhood office environments—dual anchors for Lower Bridge Street—at 6th & Bridge and the Riverfront/Gateway will supplement the stable existing shopping area from 3rd to 5th Streets, which will continue more or less as it exists today.

We recommend that attention be given to the spatial connections between Lower Bridge Street and the neighborhoods around it. A more attractive and integral street will draw shoppers and residents on its own, but Lower Bridge Street should also be a useful place, serving as a link between Lowell, Christian Hill, and the neighborhoods immediately east and west of the street. Existing view corridors should be preserved and enhanced, and careful attention should be given to ensuring that the

Development Opportunity Zones

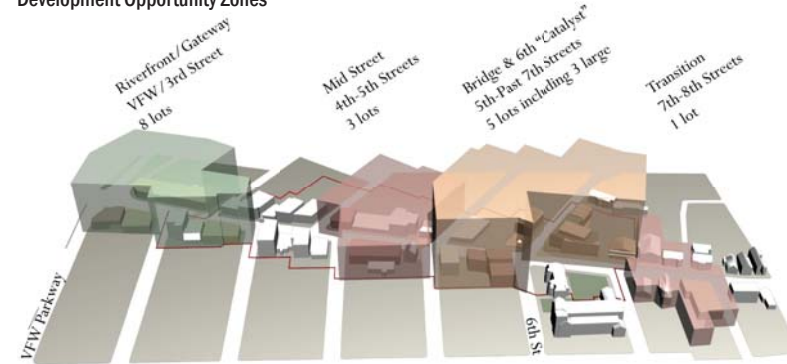

Zone 'heights' indicate the relative scale of the redevelopment opportunities, not building height.

Projected Transformation Path - Street Activity Intensity



Building Colors: White (existing), Orange (catalyst development), Yellow (other available sites), Red (future redevelopment opportunities)

Projected Transformation Path - Built Form & Time

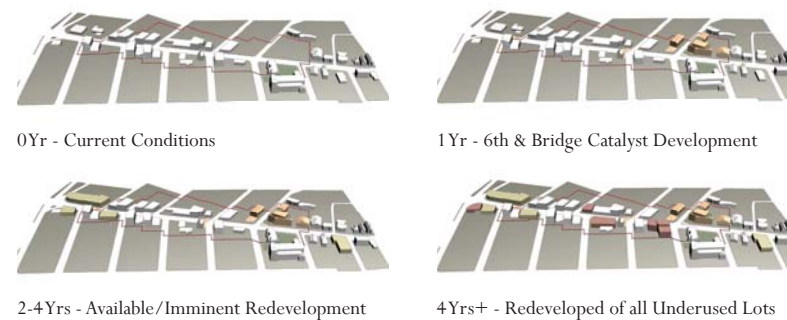

large parking lots on either side of the street are not a physical and visual barrier.

Land-Use Policy Recommendations

To help achieve the vision for Lower Bridge Street, we recommend consideration of a number of enhancements to the existing land-use regulations for the NB zone:

Policy Goal	Land-Use Change
Preserve and accentuate the neighborhood's compact scale	Mandate minimum Bridge Street lot frontage ratios of 75 percent, with carve-outs as necessary for egress in and for landscaped park/community garden space Require buildings with street frontages on Bridge Street greater than 50 feet to use differentiated facade treatments to reduce the sense of scale
Promote pedestrian-friendly urbanism in future development	Buildings on corner lots should have maximum setbacks of 8 ft along both street frontages, with allowances permitted on the non-Bridge Street side for landscaped open space that clearly defines the street edge and for landscaped corner plazas Enact guidelines for buildings with windows and doors/entrances facing Bridge Street (i.e., no blank walls facing the street)
Encourage new housing development above retail and commercial space	Create a new zoning category for mixed-use buildings Reduce lot area/dwelling unit ratio for mixed-use projects to 1,000 to 1,500 square feet Eliminate on-lot urban open space requirement for mixed-use buildings Remove dwelling unit limit over ground floor commercial
Anchor Lower Bridge Street with two new higher activity/usage areas centered around 6th and Bridge and the Riverfront/Gateway	Create a 6th and Bridge Overlay District with limited density bonuses (to FAR=1.5) and allowable height increases to 4 floors and 50 feet for mixed-use buildings, by special permit

We propose only an overlay district for the proposed new activity center at 6th & Bridge; however, other overlay districts may be considered for other development zones. In particular, it may be advisable to regulate heights in the Gateway/Riverfront area so as to ensure that areas further north on Bridge Street will have their visual access to the river and the Lowell mill buildings unimpeded.

Other urban design measures may be considered as well. Form-coding and contextual zoning tools, which regulate architectural styles, may be considered for new development, to further ensure that the traditional New England main street character of Lower Bridge Street is maintained in future development; however, such policy alternatives are beyond the scope of this report.

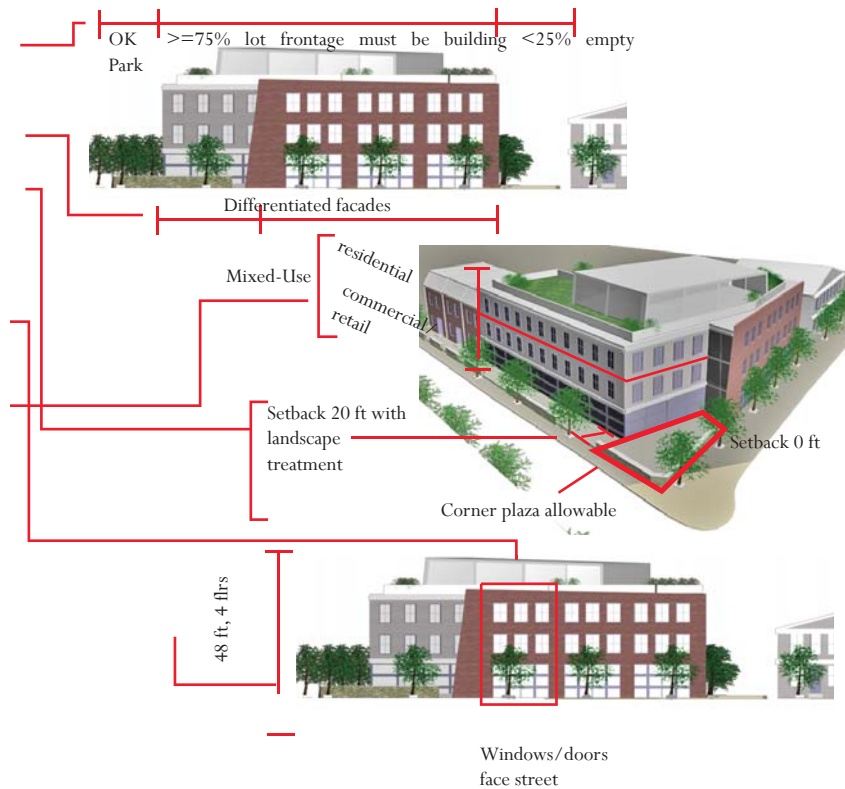

Parking and Land Use

Another area of consideration are land-use regulations concerning parking. Excessive parking adds to the cost of development and promotes single occupancy vehicle trips. Reduced parking requirements, on the other hand, can encourage the use of alternative transportation, lower development costs, and encourage more efficient use of parking facilities. We recommend the following zoning changes:

- Allow parking requirements to be met through the long-term lease of spaces from other private land-owners or in municipal lots/garages;
- Reduce the parking requirements for residential units to 1.5 spaces/unit as long as 1 space is designated and separated from the general parking pool on mixed-use sites;
- Remove disincentives in the zoning code for the expansion or change of uses by limiting the applicability of the parking requirements only to the new incremental demand for parking created by the change or expansion, as opposed to both the expansion and the existing space;
- Allow available metered on-street parking to count toward commercial and retail parking requirements;
- Establish lower parking requirements (e.g., 20 percent) for sites located within 1/2 mile of transit, contingent upon improved bus service, to handle increased ridership levels;
- Allow substitution of car parking with bicycle parking in a ratio of 1:5 in uses that are required to provide 10 or more parking spaces, require provision of bicycle facilities near the edge of the lot but close to buildings;
- Provide for a small business exemption for businesses that generate requirements for 4 or fewer parking spaces;
- Use-specific changes: (i) reduce senior housing requirement to 0.5 spaces per unit, (ii) reduce secondary educational parking requirement to 3.0 spaces per instructional room, (iii) reduce restaurant and clubhouse parking requirements to 1.0 space per 350 sq ft, (iv) progressively decrease parking requirement ratios for large retail—require 3.3 spaces per 1,000 sq ft. or the first 10,000 sq ft, required 2.5 spaces per 1,000 sq ft for 10,001 to 12,500 sq ft, require 2 spaces per 1,000 feet for 12,500 sq ft and above.

Carefully considered restructuring of the parking requirements in the existing code will be required to maintain the streetwall and main street character of Lower Bridge Street. At present, many smaller lot owners will find it difficult if not impossible to develop or re-develop their sites in ways that comply with the vision existing requirements for parking. Instead, these policies favor buildings that turn their backs to the street and leave large gaps facing the street.



Figure 1: Sidewalk cracks on Lower Bridge Street

Parking and Transportation

Our parking and transportation recommendations come from the vision to make Bridge Street a friendly environment that supports its small businesses and the community. In order to make it a place where people can live, work, and shop, Lower Bridge Street needs to effectively manage high levels of cars and pedestrian traffic.

Parking Management Goals

- Existing parking spaces are occupied at all hours
- Parking turnover supports retail activities
- Parking rules are enforced
- Parking generates city revenue that is reserved for Centralville improvements

Pedestrian Amenities

In order to achieve a vibrant, healthy neighborhood and business district as outlined above, pedestrian activity is essential. Residents are more likely to walk in and around their community if they have high-quality pedestrian facilities that provide a comfortable and pleasant walking environment. Some of these already exist on Bridge Street including wide sidewalks, street trees, and a series of community gardens. There is still room for improvement along Bridge Street.

Sidewalks

Although the sidewalks on Bridge Street are a good width, the paving has fallen into disrepair in many locations and is cracked and uneven (see Figure 1). We recommend repaving the existing sidewalks using easy-maintenance paving material that will level the surface level and make it more attractive. Possible materials include various patterns of brick or stone. It is also necessary to install wheelchair accessible ramps at all street crossings.



Figure 1: Existing mural at 3rd Street, possible mural on 120-foot wall behind Store 24, with and without a mural.

Street Furniture

A variety of street furniture can be installed in the business district that improves both the aesthetic character of the area and the level of comfort experienced by pedestrians. We recommend that some combination of the following elements be installed along Bridge Street at strategic locations with significant pedestrian traffic. This plan should remain consistent with any recommendations for other locations in Centralville.

- Seating: benches provide rest spots for pedestrians in addition to allowing people to enjoy the atmosphere of Bridge Street in a comfortable way.
- Trash cans discourage people from littering in the area and add to the idea of Bridge Street as an outdoor room.
- Bicycle racks encourage bicycling as a form of transportation by providing secure places for cyclists to leave their bikes while they shop and eat on Bridge Street. By locating bicycle racks appropriately the sidewalks can be kept clear for pedestrians.
- Lighting is important in a business district that stays open after dark. Lights should illuminate the sidewalks, crosswalks, and any public places and seating areas.

Signs

Signage also has the potential to improve the visual character of Bridge Street and

help to define the identity of the area. Installing signs that strongly reinforce the neighborhood identity at the Gateway intersection and along Bridge Street is recommended. This could come in many forms, but banners are one commonly used method of neighborhood identification. In addition, we recommend a signage consolidation program along Bridge Street in order to remove redundant regulatory signs and reduce visual clutter. Clarity and visibility should be the main goals of a signage system.

Landscaping

Street trees planted along Bridge Street would provide shade in the summer and generally beautify the streetscape. In order to avoid warping the sidewalk surface as the trees grow, it is important to install appropriately sized tree pits and gratings that allow for easy maintenance. Centralville already has a network of small community gardens throughout the neighborhood, and we recommend that the city continue to support and possibly expand it. Planter boxes along Bridge Street could also help to improve the appearance of Bridge Street and double as additional seating.

Public Art

The aesthetic and community benefits of public art have caused a surge in projects over the past decade. Bridge Street currently has one mural on the side of a building between 3rd and 4th Streets as shown in Figure 3. Another good place for a mu-



ral—perhaps painted by children from nearby schools—is on the 5th Street side of Store 24, which is currently a 120-foot stretch of blank wall (see Figure 4).

Pedestrian Safety

Walking on and around Bridge Street can be very dangerous because of the high traffic volumes and speeding cars. Improving safety should be a primary concern in order to meet goals of pedestrianization and economic growth in the business district.

Traffic Calming

Traffic calming is a popular technique to slow speeding traffic on busy streets and sends the message that the city’s priority is to keep pedestrians safe. Here are some ways to implement traffic calming on Bridge Street (Figure 1):

- On-street parking provides a buffer between pedestrians and moving vehicles. Parallel parking is provided along most of lower Bridge Street and should be encouraged in any area with heavy pedestrian traffic. Curb cuts (driveways) should be limited to the minimum number of necessary access points to allow for more parking spaces. Signage and street painting should be consistent to indicate times when parking is prohibited.

- Median strips on busy streets can serve the dual purpose of slowing moving cars slightly and provide refuge locations for pedestrians attempting to cross a wide street. They can also add green permeable surfaces to the streetscape.
- Bulb-outs involve extending the sidewalk out farther into the street at strategic locations. Bulb-outs at corners are an effective way to prevent cars from speeding around corners. Bulb-outs located at street crossings shorten the time that pedestrians must walk through traffic. Bulb-outs located at bus stops allow buses to stop without pulling into and out of traffic.
- Decreasing turning radii slows turning cars to safe speeds and helps them avoid collisions.

Street Crossings

Visible street crossings are important to ensure the safety of pedestrians where they are the most vulnerable. The two most important aspects are the design of the crosswalks themselves and any signal systems to accompany them. Colors, textures, patterns, and grade changes all increase the visibility of crosswalks to make them safer and more attractive for pedestrians. A neighborhood’s ultimate choice depends on price, ease of installation, maintenance requirements, replacement frequency, and design preferences. The stamped asphalt option (Figure 5) is colored and designed to resemble bricks.



Figure 1: Car ownership in Centralville. (Source: US Census 2000)

When considering signals for street crossings, the community should decide whether a pedestrian phase should be automatically included in a light cycle or should be triggered by a push button. Whenever possible, pedestrians should be allowed to walk parallel to moving traffic in order to decrease their waiting time. When a signal is not the optimal method of traffic control, stationary signage should be included that alerts drivers to the presence and priority of pedestrian in crosswalks (Figure 1).

Parking

Everybody agrees that there's a "parking problem" in Centralville. But what exactly does this mean? A close look at the community's parking needs reveals a different set of needs in the commercial district and residential areas.

Residential Parking Demand

Parking has been recognized as a major issue for residents of Centralville's neighborhoods. Especially for those residents west of Bridge Street, demand appears to have far outstripped the available supply of on-street and off-street spaces. The narrow streets and small driveways were designed to accommodate people in a vibrant walkable neighborhood, but not necessarily to accommodate their cars. This is evidenced by the common sight of cars parked on the sidewalk and front yards



Figure 1: Crosswalk stamped to resemble brick.

paved with asphalt in order to create more space for cars. In addition, the building commission issues signs for residents to reserve parking spaces in front of their homes (Figure 1).

In all areas of Centralville, new development is seen as contributing to the parking problem in an already congested area. To combat this problem, the recently updated zoning code requires two off-street spaces for each new dwelling unit. Is this zoning solution the best way to address the residential parking problem?

Analysis

In order to gain a better understanding of residential parking demand in Centralville we collected some basic statistics from the 2000 US Census. This demographic information is presented in Appendix 1 for the three census tracts in Centralville and for the whole area. We can see that there are, on average, 1.27 workers older than 16 in each Centralville household.

By using vehicle ownership data, we are able to estimate the number of residential automobiles in Centralville at 7,883. This total number of vehicles can be broken down geographically to provide a more fine-grained analysis of where primarily residential parking facilities should be located (Figure 1). We can see that almost 60 percent of Centralville households have 1 or fewer vehicles and more than 90

Centralville Parking Map 440 existing spots, including on-street parking



(Source: site visits and Lowell GIS)

(Source: Site visit)

percent have two or fewer vehicles. The low number of households with high car ownership levels indicates that it may be possible to implement maximum (instead of minimum) parking requirements or some sort of residential parking permit system.

We can see a summary of the vehicle ownership data in Table 1—including the fact that there is one car for every two residents of Centralville. There are 9 percent more cars than workers in the area. When combined with the fact that only 74 percent of workers drove their own car to work, we can see that a large proportion of cars in Centralville are used solely for non-work trips, such as shopping or recreation. This presents an opportunity to decrease the number of cars, and therefore parking spaces required in the residential neighborhoods by improving non-car transportation.

With an average household size of 2.78 there are, on average, of 1.39 cars per household. However, current zoning requires an addition of two parking spaces for each dwelling unit constructed. If this standard were applied to the existing housing stock, the neighborhoods would need a total of 11,822 parking spaces. This would require almost 4,000 more spaces than could be currently used by the residents. On average, this is an over-zoning of two-thirds of a parking space per household, a very large differential.

(Source: US C

Table 1 Centralville Residential Vehicle Data, by Census Tract

	3102	3103	3104	Total
# Cars total	3,340	3,266	1,277	7,883
# Housing units	2,288	2,414	1,209	5,911
Req'd Parking Spaces	4,576	4,828	2,418	11,822
Extra Parking Spaces	1,236	1,562	1,141	3,939
Extra Spaces per HH	0.54	0.65	0.94	0.67

Commercial District Parking Demand

Commercial parking is an entirely different story than residential parking. There appears to be an abundance of parking within a half a block of Bridge Street, but it's mostly underused, fenced off, and privately owned (See Figure 1). The supply is there, but it's not available for public use. How can Centralville make sure that customers can find a spot when they need one?

Analysis

In order to gain a better understanding of parking demand on lower Bridge Street we ran the same test as above, this time using data from Lowell GIS and site visits (Table 2). We can see that there are 425 total parking spots, but only 95 of them are available to the public.

Table 2 Current Parking Spaces Near Lower Bridge Street

Public on-street spots	84
Public parking lot spots	11
Private parking lot spots	330
Total parking spots	425
Spots req'd under current zoning	720

By calculating the square footage of commercial space near Lower Bridge Street, we see that current zoning would require a total of almost 720 spaces. This would require an addition of 390 parking spaces, beyond the 330 private parking lot spaces that are underused.

We believe that an adequate public parking supply will play a crucial role in economic development, so we recommend the following interventions be taken to maximize Centralville's current parking supply while protecting the town character.

Parking lots are a barrier

The current configuration of parking lots isolates the Lower Bridge commercial district from the residential neighborhoods because several blocks of storefronts are

backed by large, mostly unoccupied asphalt. This isn't good for morale and it's not good for Centralville's economy. Many lots are fenced off and not accessible to the general public. We want to encourage some development on the lots surrounding Bridge Street, while maintaining an adequate parking supply. We see it in the city's best interest to obtain access to one of the lots. This could be done a few ways: either the city could purchase a parking lot and lease some spots back to businesses that need dedicated parking or the city could lease some parking from private lots to be shared by the general public.

Parking meters

On-street parking is a great resource—Centralville should make best use of it because there isn't a lot of off-street public parking available. One possible way to ensure curb parking spaces are used for customers is to put meters on Bridge Street and cross streets within a half-block, which should discourage people from parking long-term, such as employees. Meter revenues can be used for maintenance and pedestrian improvements on Bridge, and also to create other opportunities for public parking in the business district.

Parking Pricing

For any parking reduction effort to be successful, it must be coupled with appropriate parking pricing. Unless drivers pay for it, the true cost of parking is borne by everyone in a city, in the form of higher rents and higher retail prices. By reducing the amount of free parking available, a city can discourage single occupancy vehicle trips, and in turn reduce demand for parking.

Census 2000)



Figure 1: “Church parking only... Others towed at owner’s expense.”

Shared Parking

We suggest using parking facilities efficiently by sharing as much parking as possible between different land uses that have different peak parking demand periods. For example, residents who commute to work by car may need their parking spaces primarily at nighttime while retail shoppers need parking primarily during the day-time. In these situations, it might be possible to establish an agreement between residents and retailers to lease spaces during times when they do not need them. To this end, we suggest:

- implementing Lowell’s shared parking table in Centralville and allowing lot owners to set up long-term leases or contractual agreements for a shared parking setup; and
- creating incentives for owners of existing lots to open them up to new shared parking agreements. For example, the Church of the Nazarene on VFW Parkway has a large lot that is only full when church is in session. This would be a good location for parks and riverway visitors to park. The 5th Street Baptist Church could be another shared parking opportunity (Figure 1).

District Parking

District parking occurs when a public agency or an organization, such as the City of Lowell, assumes responsibility for managing on-and off-street parking in a defined geographic area. Parking districts make it possible to coordinate parking demand between different developments and land uses, helping to reduce both the overall amount and cost of parking. Because Centralville is a neighborhood that already has a lot of parking we recommend that developers of new construction be allowed to meet the parking requirements by leasing unused parking on other sites within 800 feet, such as an underused parking lot.

In-Lieu Fees

Developers may pay into a municipal parking garage fund or traffic mitigation fund instead of providing required off-street parking spaces. These in-lieu fees (up to a maximum of 20 percent of required parking spaces) provide a wider range of choices to developers, who might prefer to develop an entire parcel without parking. In-lieu fees could also support district-wide or shared-parking and allow developers to redevelop historic sites that would otherwise not be possible, due to unattainable parking requirements. Studies have found, however, that in-lieu fees

are only acceptable to developers if the city guarantees that it will build a central parking structure.

Unbundle Residential Parking

In almost all housing, the cost of parking is “bundled” into a resident’s lease or purchase price. Whether households use 0, 1, 2 or 3 parking spaces, they all pay the same amount for the parking, which is included in the total sale or lease price. Separating prices for housing and parking can reduce both the cost and demand for parking in a development. Unbundling allows consumers to choose whether to pay for the cost of parking, independent of the cost of housing. This could also relieve some on-street parking pressure by allowing neighbors in older houses to park in any excess parking spaces in new developments. Developers could sell or rent those parking spots at the same rate as residents would pay if it were bundled into the cost of the unit.

Residential Permit Program

A parking permit program has the potential to raise money for Centralville, improve streetscape by obviating unattractive private “no parking” signs, and provides a method to control who parks where.

- A progressive fee system discourages ownership of multiple cars by charging more money for each new permit.
- Funds paid into permit program should be reserved for Centralville programs such as improved pedestrian, bicycle, and transit infrastructure, and a public parking fund (future parking garage and metered parking in commercial district).
- Include visitor permits for short-term parking.
- Do not issue more permits than available parking spaces, including curb spaces.

Parking Demand Reduction

Parking management strategies should include ways to reduce demand for parking. To this end, we recommend that the City of Lowell support alternative modes as viable transportation options.

Public Transportation

The success of many of the above parking recommendations depend on improving transit service to reduce demand for parking spots. Urban areas with high densities, tight parking supplies and low automobile ownership typically emphasize public transportation as a viable option. This has not been the case in Centralville, despite meeting these qualifications, and transit service remains poor along Bridge Street and throughout the neighborhoods. While three bus routes serve some portion of lower Bridge Street, all of them have very low frequencies (between one and two buses per hour during the weekday peak times) and make it very difficult to use it as a primary means of transportation. Improvement in service frequencies by the Lowell Regional Transit Authority would be beneficial to business and residents, and is crucial to reduce reliance on cars within Centralville. We also recommend that the city explore the possibility of an express shuttle to the commuter rail station from Bridge Street during peak commute times.

Transit Passes

Offering subsidized or free transit passes to employees has been shown to increase transit ridership and decrease parking demand. The cost of transit passes can be far less than the cost of building and maintaining parking spaces. Empirical data show that offering transit passes to all employees of a business can reduce parking demand by up to 20 percent. Transit passes should also be offered to tenants and homebuyers as well as employees.

Bicycle facility improvements

By investing in good bicycle facilities—secure and weather-protected bike racks, racks on buses, and a bike lane network—the city can offer an attractive alternative to driving to Bridge Street. Because this commercial district is a destination primarily for locals, an effort to make it easy for them to ride a bike there would encourage people to leave their cars at home, which would decrease demand for parking spots. Automobile parking facilities should incorporate sheltered bicycle parking, designed in accordance with the bicycle parking guidelines outlined in Appendix H of the Commonwealth TOD Bond Program Guidelines: www.mbta.com/projects_underway/pdf/tod/TODGuidelines_FINAL_091905.pdf.

Bridge Street Economic Development

The goals for economic development on Lower Bridge Street are an integral part of the vision for a vibrant, diverse, and economically sustainable place to operate and grow a business. Local business owners, the City of Lowell, and Centralville leaders communicated their ideas for achieving various economic development objectives through field visits, informal surveys, interviews, and public meetings. These ideas are the foundation of the economic development goals and recommendations detailed below for the Lower Bridge Street Commercial District (LBCD).

Goals:

- Strengthen businesses
- Preserve LBCD as an economically sustainable business district
- Attract a diverse mix of businesses
- Increase the variety and quality of products to meet needs of local residents
- Create incentives for private investment and redevelopment
- Protect the character of the LBCD
- Strengthen the identity of the LBCD

Assessment and Findings

Table 1: Business Survey Results

	“Poor” to “Fair”	“Good” to “Strong”
Community Support	22%	78%
City Support	44%	56%
Traffic	22%	78%
Safety	22%	78%
Cleanliness	33%	67%
Façade/Signage	45%	55%
Business Mix	22%	78%

The Business Environment

Businesses are optimistic about operating on Lower Bridge Street. Many business owners believe that things are working and the business environment is “good.” However, 55 percent of surveyed businesses said that their business performance was slow to fair in the last two years. Forty-four percent of business owners do not know if they will continue operating on Bridge Street two to three years from today. Only 22 percent of businesses have invested in their business within the last two years.

Community Support

Seventy-eight percent of business owners find that community support is good to strong, and cite customer loyalty and support from the surrounding neighborhood as being very important. However, businesses also share that there is little communication between the business community and local organizations and institutions, and community events programming as a way to strengthen mutual support.

City Support

Business are generally pleased with city services. However, businesses also share that communication and relationships with various city agencies and public officials are weak and need to improve. Moreover, 78 percent of businesses expressed interest in city-sponsored business support services such as access to low-interest capital and technical assistance.

Safety

The police substation is serving the LBCD well. Businesses share that the beat cop was critical in creating a sense of safety within the district, and believe the presence of the Lowell Police Department is responsible for maintaining Lower Bridge Street as a safe place. Residents also said they miss having the bicycle cop patrolling the area.

Business Mix

There are nearly 45 businesses in the LBDC and a vacancy rate of only 9 percent. Most of the businesses are service-oriented, with a strong presence of personal care and personal business services.

Opportunities for Economic Development on Lower Bridge Street

- Opportunity for new entrepreneurs—low rents, low operations cost, easy public permit process. One business owner said, “You make your own opportunities in Centralville.”
- Opportunity to redevelop vacant parcels in a way that catalyzes further development in the neighborhood by making the street more attractive and inciting uses that create jobs.
- Incentive tools and tax breaks support potential investment.
- Businesses on Lower Bridge Street tend to stay open long-term. Owners cite low vacancy and a stable workforce as reasons for stable operations.
- Based on community input and business mix findings, there is demand for more convenience retail, restaurants, and pharmacy types of businesses.

Challenges:

- While many businesses plan to stay in Centralville as long as possible, some business owners are unsure if their business will be viable in the next few years.
- The LBCD needs a greater balance of comparison, convenience, and service shops. Greater business diversity meets a variety of shopper needs, which will attract customers.
- Most of the current parking is not accessible to customers. While there is a perceived lack of parking along Lower Bridge Street, there is an abundance of parking spaces in the LBCD.
- Most small business on Lower Bridge Street are not eligible for existing redevelopment incentives and tax breaks administered by the city.

Achieving the vision for Lower Bridge Street: Strategies and implementation

Support existing businesses—Business support will strengthen businesses and ensure a healthy and sustainable business environment.

Implementation: Through its Economic Development Office (EDO) and Business Support Center (BSC), the City of Lowell currently acts as a service provider, clear-

inghouse, and referral center for businesses interested in obtaining loans, technical assistance, training, and other general business resources. Based on the business survey and informal interviews with local business owners, very few businesses have used these resources and many others are unfamiliar with them or do not know how to access them.

The EDO and BSC can strengthen its business support efforts by developing and marketing new tools that are appropriate to the needs of LBCD businesses. Some of these tools include include:

- Ongoing communication with small businesses. This is important to keep them abreast of services and other available opportunities available to them. Small businesses respond best to direct contact and communication, such as site visits, newsletters, and flyers.
- Resource packaging: Many business support centers around the country leverage resources using a carrot-and-stick approach, for example, offering grants with training requirements. As another example, various Main Street programs offering small loans for façade improvements require that small businesses adhere to specific physical design standards. This effectively allows business owners to improve their individual business while contributing to a secondary business objective of improving the physical character of the district as a whole.
- Diverse loan products: Business needs vary. LBCD’s business environment is characterized by small, independent, family-owned and -operated businesses that are typically oriented toward convenience and personal business products. Loan tools that reflect these financing needs will have greater appeal and impact for potential borrowers.

Create financing and business redevelopment incentives to promote local investment and business activity.

Implementation: Lower Bridge Street is currently part of the Renewable Communities (RC) program and the Economic Opportunities Area (EOA). These Federal and State programs offer a variety of tax breaks to small businesses like those on Lower Bridge Street. These include wage credits, tax deductions, capital gains exemptions, and development tax credits. The EOA State program, however, ap-

plies primarily to research and development types of businesses. Additionally, the wage credits included in EOA benefit mainly moderate- to large-scale businesses. Moreover, based on conversations with business owners, it is not certain that local businesses are taking advantage of the deductions and credits for which they are eligible. An assessment of the usefulness of current incentives will help inform the programs as well as guide additional exploration of tools that might be more effective for the LBCD. Some additional incentive tools that the City of Lowell should consider adopting in the near term include:

- **District Improvement Financing (DIF)**—The formation of a DIF District along Lower Bridge Street can serve as a significant incentive for redevelopment considering there is currently 150,000 to 200,000 square feet of available land for development in the near term. By capturing increased revenues from new development activity, the DIF can effectively be used to facilitate financing related to new development and public infrastructure projects within the district.
- **Leverage public resources**—In consideration of the current demand for parking in the LBCD, the city should adequately plan for future economic growth by obtaining control of a larger, strategically placed parking lot. The city can leverage its current asset, the parking lot on Bridge and 2nd Streets, using it as a financing tool and mechanism to acquire additional land. Another possibility would be to transfer City equity from its current property to a larger property to be used for public parking. This would accommodate more cars to serve a larger number of current and potentially new businesses as commercial activity increases along Lower Bridge Street. Moreover, this would create development opportunities by allowing a private entity to acquire the current city parking lot for redevelopment.

Adopt a business district model to serve as a communications and implementation vehicle for a variety of the district's initiatives.

Implementation: A business district model can help support a diverse mix of programs and activities. Some of the more popular models across the country include the traditional small business association (SBA), a business improvement district (BID), and the nationally run Main Street Program. While the primary goal of these models is to support local businesses, they have distinct functions and programmatic objectives. For example, the small business association is led by local busi-

nesses, but is traditionally geared toward marketing, networking, and business support. However, the Main Street Program is incorporated as a 501(c)(3), gets public operating support and is geared toward district revitalization through promotion, design, and economic restructuring. Each of these is further detailed below. As an initial step towards initiating a business district model, the City of Lowell should undertake a business community input process. This would help the city to connect with local business owners to see what model, or model variations, would best fit the district based on expressed business needs. Based on the information received from the business and community leaders, it is recommended that the City specifically explore incorporating the following components and functions into the business support program: district marketing and promotions, event programming, business support services, new business outreach, and advocacy. Additionally, the city should play a lead role in facilitating program formation and serve as partner for various program initiatives.

Business District Programs

Program Type

Main Street

Description

The Main Street Program is administered by the National Trust for Historic Preservation. As a tool for the revitalization of America's older commercial districts, the Main Street program encourages economic development through four components: design, economic restructuring, promotion, and organization.

How would it work in Centralville?

The Main Street program is intended for traditional business districts, such as Lower Bridge Street. With a core of 45 businesses, there is an economic base on which to build. By working on small, incremental revitalization that will lead to larger projects over time, Centralville can begin to realize a traditional main street vision for Lower Bridge Street. Money must be raised for Main Street operations on Lower Bridge Street and the accompanying revitalization efforts.

Who would be responsible for it?

There must be a broad base of support in both the public and private sectors for this program to be a success. Business owners and city officials must be committed to the four components of the Main Street program. This is a consensus-based program that depends on volunteers from the community to get the program off the ground.

Program Type

Small Business Association

Description

A small business association is a membership organization of owners and employees of small businesses. The idea is that together, businesses can achieve more than they can as single entities. The association could be focused on promoting a particular business area, networking among businesses, and growing the amount and type of businesses in an area. A small business association is not governed by a city government.

How would it work in Centralville?

Business leaders of LBCD Street would come together to support one another in creating a vibrant economic district by creating strategies and implementation plans that will ensure the sustainability of their businesses. Members can identify issues of importance to the business community and create strategies to address the issues.

Who would be responsible for it?

Business owners will initiate the process of forming an informal association and engage the City as a partner.

Program Type

Business Improvement District

Description

A Business Improvement District (BID) is a private organization that would supplement Lowell city services to increase economic development through retention of existing businesses and new business development in the Lower Bridge Street commercial district. A BID is generally a nonprofit 501(c)(6) corporation with a board

of directors to govern its activities. Business Improvement Districts are established by businesses in a defined geographic area and often have a professional BID staff managing the project.

How would it work in Centralville?

Business owners in the LBCD could vote to self-assess a special tax that would fund programs for management, maintenance, development, and promotion of businesses in the area.

Who would be responsible for it?

Business owners in the LBCD would create a resolution to be presented to the City of Lowell to enact a special tax assessment for the BID. Once the city approves that, a majority of business owners in the proposed BID district must vote to enact the special tax authority. Once revenues are collected, a staff to administer the BID is hired and the program is initiated.

Catalyst Property at Bridge and 6th Street

We have identified the 6th Street and Bridge Street intersection as a potential activity center on Lower Bridge Street. Bearing in mind our vision of Lower Bridge Street, as an integral New England main street, we have performed a detailed analysis of the development potential of the corner, from a design, programming and feasibility standpoint. We believe that well-designed projects in that part of Lower Bridge Street will provide the area with an important transitional anchor to the north, activate pedestrian activity throughout the retail strip and fill vital gaps in the street's retail and housing options. Our recommendations should be taken in the context of the land-use recommendations, which include provisions for an overlay zone for 6th Street and Bridge Street.

The large size of the site (40,000 square feet) on the northwest corner of Bridge and West 6th streets, coupled with its prominent location at an important crossroads, make it a potential catalyst property for the surrounding area. Currently this three-lot site sits empty and detracts from the community.

We kept in mind several community requests: (i) an additional sit-down restaurant on lower Bridge Street, (ii) retail space for a possible pharmacy, (iii) community green space, and (iv) increased pedestrian and traffic safety by keeping driveways away from the intersection at Bridge and West 6th streets.



Figure 1: Current site—vacant

Mixed-use components

The potential catalyst development includes the following mix of uses (Figures 2, 3, and 4):

Restaurant

A 3,750-square-foot sit-down restaurant is located on the corner of the ground floor in the main building with additional seating capacity on the outdoor terrace.

Retail

The restaurant is flanked by a total of 9,500 square feet in ground floor retail space to compliment the existing retail space on Bridge Street. This is the possible location of a new pharmacy, which has been identified by the community as one of the retail needs of Lower Bridge Street.

Office

Above the restaurant and retail space, there is 6,600 square feet of office space that could be used by one local office tenant for a headquarters location. This space could also be subdivided between several tenants who need less space.

Residential

There are eight apartment units above the retail, restaurant, and office space in the corner building. On the northeast corner of the site, there are two duplexes (four units), which provide a transition to the residential uses north of the site on Bridge Street. Near the southwest corner of the site, there are three townhouses with semi-private patios and gardens, transitioning to the residential uses on West 6th Street. Additionally, across West 6th Street, on a portion of the current Store 24 site, there are four townhouses adjacent to a large community plaza and green space. These residential units also serve to create a smooth transition from the commercial uses on Bridge Street to the residential use on 6th Street.

Site Considerations

Parking

Behind the project there is room for 52 parking spaces, in addition to 20 on-street spaces on Bridge and West 6th streets. Thus, the 15 residential units each have two

parking spaces and the retail, restaurant, and office uses have 42 spaces that can be used in accordance with a shared parking schedule. There is also sufficient parking on the Store 24 site for the additional eight parking spaces to accommodate the four townhouse units on that site.

Green space

As planned, this potential catalyst development has green space to be enjoyed by the tenants of the development and the entire community. On the southwest corner of the West 6th and Bridge Street intersection, on the Store 24 site, there is a large community plaza green space, which could host a community information kiosk or even a small cafe in a gazebo. In front of the townhouses on West 6th Street, both on the north and south sides of the street, there are semi-private patio and garden spaces. Along Bridge Street, there is a 15-foot community garden in addition to other trees and landscaping. On the roof of the main portion of the potential catalyst development, there is a large roof garden for the tenants of that building. The parking lot behind the development has varied landscaping treatments including trees and garden beds lining the perimeter.

Continuity and transition

As illustrated in Figure 5, the potential catalyst development mends the current gap in the existing street wall along Bridge Street, providing contextual buildings consistent with aspects of the existing street character identified by the community as being important. The scale of the proposed buildings is also consistent with surrounding buildings. The development also serves as a transition property both from the higher-intensity commercial uses on Lower Bridge Street to the residential uses on Upper Bridge Street, as well as to residential program on West 6th Street.

Feasibility

Financial feasibility—From a high-level financial perspective, using current construction costs and market rents, this potential catalyst development is financially feasible and possibly more profitable than a lower intensity industrial or convenience store use on the site.

Regulatory feasibility—The potential catalyst development will be well within the bulk (floor area ratio) restrictions in place under the current zoning ordinance; however, some flexibility would be required with respect to mixed-use function, the

mixed-use dwelling unit cap, height, floors, urban open space, parking and parking lot design. The project is fully compliant with our proposed zoning overlay for the 6th and Bridge Street area, as discussed elsewhere in this chapter, if it is enacted.

With respect to parking, the current regulations would require an additional 20 spaces (beyond the proposed 42 spaces) for the office, retail and restaurant components of the development. Given the presence of underused parking on Lower Bridge Street, we support the implementation of shared-parking between complementary uses, such as office, retail, and restaurant, on this site.

Illustrations

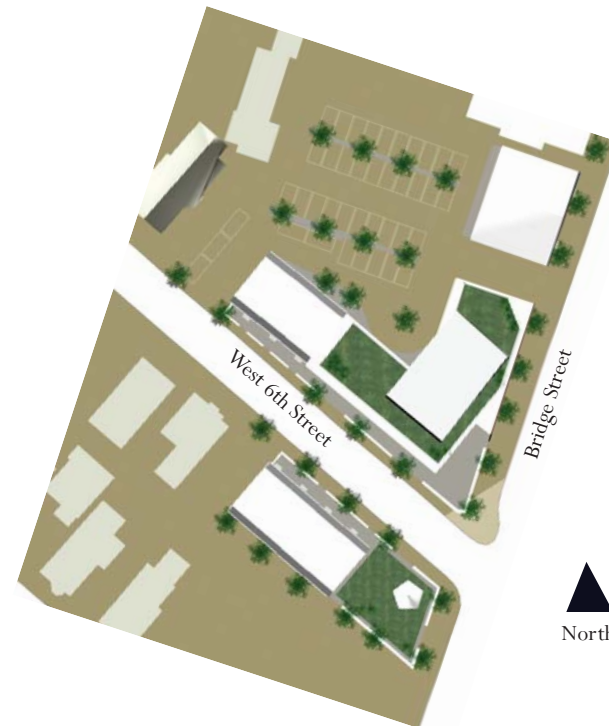

Figure 2: Site Plan



Figure 4: Potential catalyst development (Elevation)



Figure 5: View of site looking south (towards Downtown Lowell) on Bridge Street



Figure 3: Potential catalyst development (Perspective)

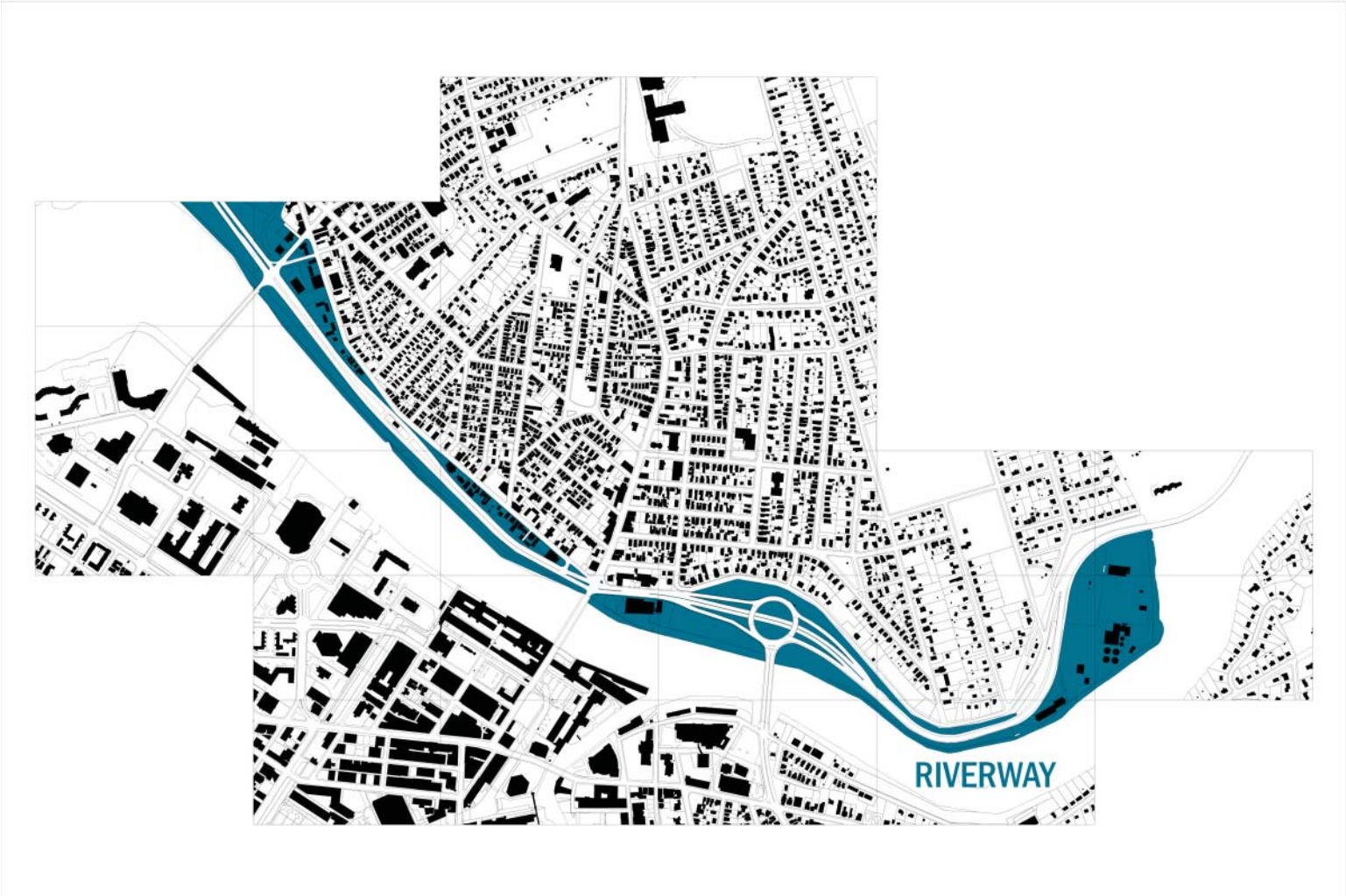



Figure 1: View towards the riverfront from Centralville

A VISION FOR CENTRALVILLE'S RIVERWAY

Centralville and the City of Lowell, despite the disappearance of industry originally attracted by its flow, continue to be fortunate to be built along the Merrimack River. The riverfront in Centralville is a unique and significant resource for the community, and has the opportunity to become a great amenity and attraction. Helping the Riverway reach its full potential requires thinking about it as a place of destination, connections, safety, and comfort.

Destination: The Riverway can become a gathering place for Centralville residents, and a destination for Lowell citizens through the encouragement of real estate and open space development that directly serves residents and provides an attraction for those from outside the neighborhood.

Connections: The Merrimack River forms the southern edge of Centralville (and the northern edge of Downtown Lowell). Rather than serving as a physical, economic, and social barrier, this edge should enhance Centralville's character and strengthen its visual and physical connections to Downtown. Centralville should take advantage of its striking and unique views of Downtown, which display a powerful contrast between the two neighborhoods and help each clarify their identities within the city. Art and programming should be used in Centralville to draw visitors from Downtown and to incorporate Centralville into the downtown theme of "history on display."



Figure 2: Riverfront renewal plan

Improving access and transportation between the two neighborhoods for cars and pedestrians is vital to strengthening these connections. Currently the VFW Parkway isolates the river from the neighborhood, which must be mitigated in order to help pedestrians access the riverfront. Such measures are important to the success of any development that takes place. Moreover, the design and use of development along the river should correlate with the built character of Centralville, and support the physical connections we hope to draw across the VFW Parkway.

Safety: The Riverway should be a safe place for many different types of users: parents and children, adolescents, and the elderly from many different cultures and

backgrounds. Users should feel safe from harm or accident while on site, and while accessing it. Development of vibrant real estate and open space will bring activity and needed “eyes on the street” to help promote feelings of security for users, such as children using play fields or joggers along the river path.

Comfort: Buildings and open space are “comfortable” when their uses fit the needs and desires of the users, their size and styling are appropriate to the environment, and they promote feelings of belonging and safety. The Riverway should be a space where any Centralville resident, or citizen of Lowell, would feel comfortable going.

The accompanying illustration (Figure 2) suggests how each of these broad goals influences our proposed interventions. It is important for each stage of development along the Riverway (visioning, feasibility studies, planning, and implementation) to embody the goals that are foundational to its future vision. The plan outlined here creates short- and long-term, simple and intensive interventions that intend to promote these four goals. We emphasize that strengthening the destination, connections, safety, and comfort of this place need not be expensive or attainable only in the distant future. Centralville can see dramatic improvement through focused interventions related closely to the community's goals. We hope that some mixture of the following proposals will closely match the community's needs and abilities and will help enhance this unique resource.

The River as a Resource

The Merrimack River, 180 miles in length, is New England's fourth largest watershed, and has served as an important resource for inhabitants since before the arrival of Europeans. However, the river's role in driving the early Industrial Revolution represents its most intensive use as a resource, and is perhaps the period in its history that most directly influences its relationship to Lowell and Centralville today. The Merrimack was the engine for Lowell's industrial development; the massive mill buildings, which are currently being redeveloped as museums, loft apartments, and offices, therefore congregate on its banks, providing a striking view of Downtown Lowell from Centralville. Lowell's industrial history, focusing more on producing the goods demanded in other parts of the country than on preserving the natural environment, also defines the largely neglected river that today's generation inherits.

The river's size and force has also helped to define Centralville, which displays a dramatically different character from Downtown as soon as one crosses the bridge (Figure 3). The massive brick industrial buildings stop at the river's southern edge, to be replaced by more modest wood-framed residences and businesses. Images from over 100 years ago show this same pattern: Centralville is a place for living, while Downtown is for working. Though these uses are changing somewhat as a changed Downtown becomes home to a greater numbers of residents, there is no question that, because of their different physical fabrics, "home" in Centralville will continue to mean something very different from "home" in Downtown Lowell. This



Figure 3: This early aerial drawing of Centralville illustrates the important relationship between Centralville and Downtown Lowell, as well as their contrasting characters. (Source: Boot Cotton Mills Museum)

is a positive contrast that we should enhance for the visitor passing between the two neighborhoods.

Development of the VFW Parkway in the early parts of the twentieth century (and increasing traffic in more recent decades) began to negatively define Centralville's edge. Most importantly, the Parkway cut the riverfront away from Centralville: it became very difficult to access the land between the Parkway and the river. This, combined with (and perhaps contributing to) the fact that no active public uses existed to attract residents to the space along the river, likely led to its decline as a public space. In recent years, maintenance has been inconsistent and development that could enhance the river amenity rather than detract from it has been absent. The Riverway, which has the potential to define the southern edge of Centralville in a significantly positive way and become a destination for residents, has instead attracted little development and hosts socially undesirable uses. It is therefore im-

portant that our plans strengthen this edge—Centralville should be different from Downtown—even as we keep it from serving as a wall.

We have identified four general areas of intervention in which improvements could have far-reaching positive implications for the Riverway, for Centralville, and for all of Lowell. The four criteria named above, applied to these areas of focus, serve as guiding principles for Riverway development, so that this space might become one that attracts residents and visitors through its resources and amenities, that provides a physical and psychological connection to Lowell’s neighborhoods, and that provides its visitors with feelings of safety and comfort. Again, the proposals listed below represent possibilities, not directives, and can be pursued as either short-term/inexpensive or long-term/more expensive options. A possible ordering of priorities follows our proposed areas of focus, which we hope provides some direction on how the city might proceed to reclaim the river as an amenity.

The Gateway

A principle goal for the Gateway is to signify a change in location and serve as a transition zone from the predominantly commercial Downtown, to the more residential, neighborhood business nature of Centralville. Through the architectural design, nature of activity, quality of open space, and relationship between pedestrians and traffic, the Gateway provides a great opportunity for Centralville to give newcomers a sense of what the neighborhood has to offer in terms of its cultural heritage and history, and character of the built environment (Figure 5).

Real estate development at the corner of Bridge and VFW

The parcel at 318 Bridge Street (the Tavern parcel) has the potential to transform the nature of the Gateway through enhanced development. We propose development of an anchor building at this site that creates greater street definition and more vibrant activity on the Gateway.

Consolidating the western corner of Bridge Street into a single, larger parcel could accommodate higher quality development that would adequately frame the expectations of someone entering Centralville. The parcel we foresee as optimal for de-

velopment is a 27,088 square foot area resulting from the merging of three adjacent parcels.

When analyzing the space and uses that might best fit the proposed development, we focused on the following main objectives:

- Activate the Gateway as a destination: use the corner, the most valuable space on the Gateway, for a mixed-use building. The city should consider allowing the greatest density possible (without detracting from the predominant neighborhood character). We recommend a four story building conforming to the proposed Form Based Code (see below).
- Maximize the real estate value of the location: highest and best use for the location is a combination of retail or other commercial uses (i.e., restaurant) with residential use in the upper floors. A more detailed study would determine the election of for-sale or for-rent dwelling units. The allocation of two different uses also enhances the value by allowing cross-use sharing of parking space.
- Provide for positive externalities to the business district: the development of the parcel will help shape the image of the Gateway, and thus visitors’ perception of the whole neighborhood as they enter from the bridge or VFW Parkway. The proposed four stories have sufficient mass and frontage to become a catalyst development.

In our analysis we have found that the current parking requirements for the selected uses act as a strong deterrent that effectively discourages development. As of today, the parcel offers an undervalued construction cost, providing for a great opportunity to enhance the image and value of the surroundings.

With current parking requirements (see table below), the assembled parcels could provide (under our urban design vision) an as-of-right development of no more than: (a) 13,177 sq. ft. of retail or commercial space in the ground floor; (b) 25 dwelling units distributed in three floors with an average size of 1,400 sq. ft. per unit, and; (c) 70 on grade parking spaces serving both the retail stores and the residents.

UMU District: Current Parking Requirements:

Retail	1 parking space per 600 sq. ft.
Residential	2.2 parking spaces per dwelling unit

According to our analysis, such development, constrained mainly by the parking requirements, is not economically feasible by a private developer (see Exhibit 2 in Appendix – Riverway). We have considered the advantages of current market conditions with annual leases of \$13.20 per square foot and sale prices for a 2-bedroom condo of \$190,000, and still found that the development of a desirable property for that corner will come to a loss of greater than \$1 million for the private developer.

With further analysis, we recommend that the city consider granting a variance on the parking requirements:

Proposed Parking Variance for the Gateway parcel:

Retail	1 parking space per 1,000 sq. ft.
Residential	1.5 parking spaces per dwelling unit

The rationale for this variance is suggested by the following points:

- Retail in the UMU district is more pedestrian-oriented, focused on serving the neighborhood trade area, and therefore could relax parking requirements otherwise appropriate for big boxes or malls.
- Mixed-use development allows for cross-use of parking, optimizing resources and space.
- The long frontage with street parking, resulting from the assembled parcels along Bridge Street, but more significantly along Lakeview Avenue, will benefit ground floor retail.

If such variance is provided, the recommended building could hold up to 36 dwelling units and still have the same volume and footprint. According to our analysis, in order to satisfy both the current asking price for the land and rapidly increasing construction costs, a developer would need discounted revenues higher than \$10.2



Figure 5: A signature development, combined with public investments, such as traffic calming measures, transforms this corner into a true Gateway for Centralville



Figure 4: Gateway before proposed interventions

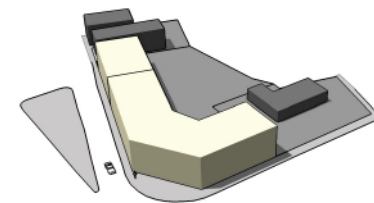

Figure 6: Illustration of new development at 318 Bridge St.

million. Below this threshold, we foresee the arrival of either low quality development or undesired uses in contrast to this corner’s prominence and the importance of activating Centralville’s Gateway.

Real estate development along the VFW Parkway

The second parcel, 15 First Street (currently an auto parts business), also has the potential to reinvigorate the Riverway with activity for all seasons. In light of its potential, we propose the development of an indoor sports facility. The one and one-half story development would provide one indoor soccer field, two multipurpose fields, a restaurant, and 60 parking spaces. This sports facility, together with the improved open space along the river, has the potential to transform the area into a recreation destination.

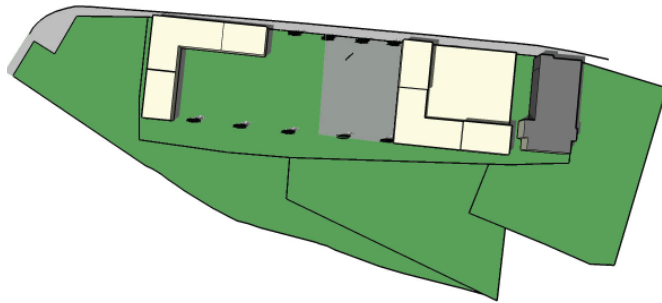

Figure 7: Illustration of new development at 15 First St.

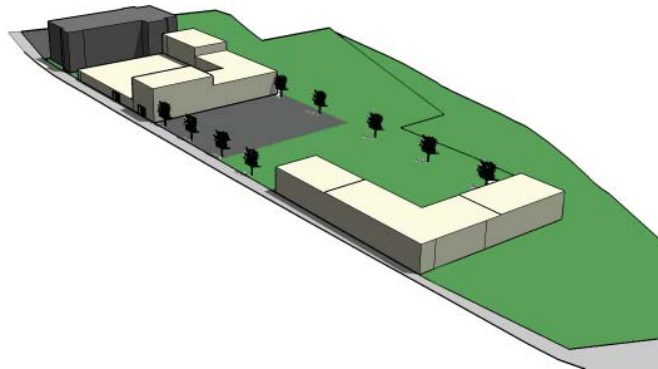

Figure 8: Illustration of new development at 15 First St.

In order to better accommodate the recommended program, we propose consolidating two parcels, 15 First Street (currently parking) and 31 First Street (the auto parts business) into a single, larger parcel. This parcel lies within the Urban Mixed-Use (UMU) zoning district, as do the other parcels on the Gateway. By design, this designation allows for a variety of permitted uses. In accordance with our vision, several different uses might have the potential to benefit and enhance the sense of destination that this valuable area could convey. The various potential uses in our analysis included developing a cultural or community center, a sports club, an art gallery to display the works of local artists, and basic residential. Financial constraints arising from construction costs and current zoning for the site, combined with the urban design considerations outlined below, make most of these infeasible, however (see Exhibit 3, Appendix – Riverway for more details).

Developing an indoor sports center on this parcel is therefore the option most likely to provide the heightened activity and use desired at the Riverway, and appears to be financially feasible. This center would serve and complement other sports and recreational activities programmed for the adjacent open space. The center could also host a food and beverages or restaurant area overlooking the Merrimack River and surrounding open space; such a use could enhance the value of the place as well as serve the needs of the community.

The facilities are designed to provide soccer and other multi-purpose sports fields in a flexible manner that adapts to various demands. The recommended building would be one story high, with a footprint of 47,480 sq. ft. It would be comprised mainly of three fields:

- Indoor Soccer, Field 1 (180 by 85 feet)
- Small Indoor Soccer and multi-sport, Field 2 (154 by 85 feet)
- Small Indoor Soccer and multi-sport, Field 3 (154 by 85 feet)

Open space at the Gateway

Open space at the Gateway to Centralville should contribute to enhancing the Riv-



Figure 9: The earlier character of Varnum Park: still recognizable, but quite different from its current state. The newspaper headline dramatically discusses the impact of the proposed parkway (Source: Lowell Historical Society).

erway as a destination and to improving the connection between Centralville and Downtown. The southeast corner of the Bridge Street-VFW Parkway intersection, known historically as Varnum Park, represents the best opportunity to accomplish these goals.

Varnum Park, a small (about 6,600 square feet) city-owned park, is currently overwhelmed by its surroundings. Overgrown shrubbery, parked cars, and speeding traffic limit the potential of this amenity and do little to invite feelings of safety or comfort to passersby. Older photographs of this space, taken before construction of the VFW Parkway, however, suggest a very different type of space, one with direct views of the river and the mills along its banks, a manicured “pocket” park taking full advantage of the light and air offered by its waterside location (Figure 9).

The City of Lowell and residents of Centralville can dramatically improve Varnum park by clearing overgrown flora and more carefully defining the park’s boundaries.



Figures 9 and 10: The image above captures the current condition of Varnum Park; the photo montage below suggests an alternative view of this unique space: more open to the sun and the views toward Downtown and the River, better landscaping and maintenance.

These actions will allow light to enter the park, enhancing feelings of comfort and safety, and would open up vistas to the water and to Downtown, quickly establishing a new walking destination in Centralville. Through simple, thoughtful landscaping and planting, Varnum Park can become an important, beautiful element of this new Gateway to Centralville.

In the longer term, Varnum Park could serve as an important public counterpart—an open space anchor—to increasing dense development along the other corners in this Urban Mixed-Use zone. As the city helps developers orient new buildings according to the small park’s layout and character, Varnum Park can become an active, lively gathering place (Figure 10).

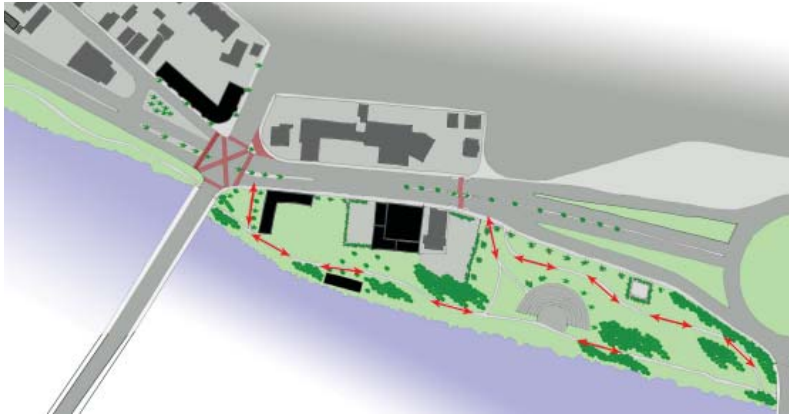

Figure 10: Illustration of revitalization plan emphasizing a focus on public access, strong links to the water, collaboratively reintegrating the waterfront into Centralville

Urban Design/Zoning

Urban design standards and zoning can contribute to activating and better connecting the waterfront to Centralville. This approach should focus on three important elements: improving accessibility, controlling the long term quality in the environment, and changing the image of the waterfront. The guidelines drafted should be general so as not to restrict creative design, and are primarily concerned with public space interaction. Our approach to the design of the waterfront intertwines the historic significance and contemporary aspirations of Centralville.

Urban design

Urban structure – form

The city should employ strategies that re-integrate the waterfront into the Centralville community. The design of the waterfront should reflect a relationship, a dialogue between land and water, with a tremendous focus on public access. Connection is therefore vital in the waterfront’s urban design, could be enhanced through the treatment of streets running perpendicular to the water’s edge, open spaces,

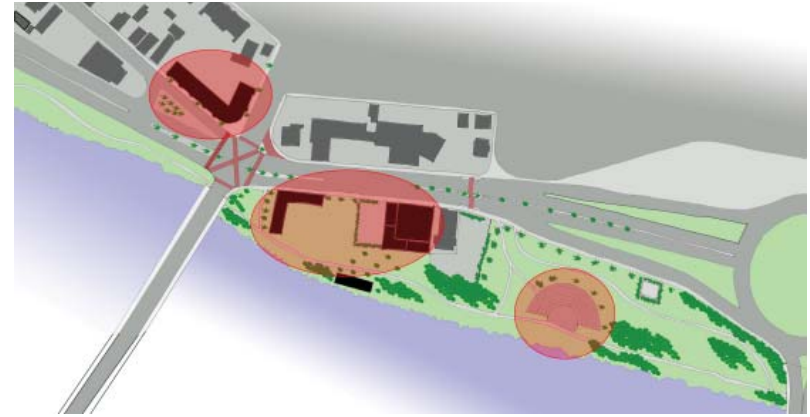

Figure 11: Illustration of revitalization plan emphasizing the diversity of activities, promoting active uses of ground floor and spaces to accommodate cultural activities

and other elements that physically link the waterfront to abutting neighborhoods (Figure 10).

Urban structure – extending and intensifying activity

Urban design standards should encourage a diversity of activities that bring people to the waterfront on weekdays, weekends, and around the clock. They should provide participants with “authentic” Centralville experiences. Ground floors should contain active uses, with street-addressing shops or other active frontages. The design of external spaces, including streets and courtyards, should accommodate a range of small and large-scale cultural, community and commercial events and activities. Through a focus on key development sites acting as catalysts, the city can pursue a strategy that extends and intensifies the number of activity nodes across the waterfront, (Figure 11).

Urban structure – movement

Improvements to the pedestrian and road network must increase the ease and directness of movement, sight lines, legibility, and safety within the waterfront and between the waterfront and surrounding neighborhood. Vehicular movement through the waterfront is critical to its vitality and its economic success and must be maintained and managed to minimize conflict with pedestrian movement (Figure

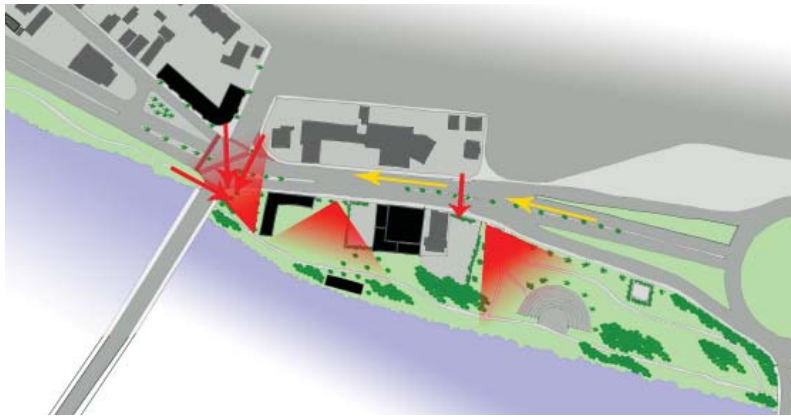

Figure 12: Illustration of revitalization plan emphasizing enhanced sightlines, pedestrian access and techniques to mitigate the VFW Parkway

12).

Urban design guidelines

- Buildings at the Gateway and waterfront should reinforce the city street pattern and avoid continuous walls parallel to the water's edge by maintaining view and access corridors, especially at cross-streets.
- Building elements on a site should generally step down in height towards the water's edge.
- The design of open space, building entrances, shop fronts, shop windows, shop entrances, terraces, gardens, arcades, and similar elements should enhance pedestrian activity and access to the waterfront. Blank walls, without windows or entrances facing onto pedestrian areas, should be avoided to the extent practicable in building designs.
- Facade treatment, building materials, and design details should complement the traditional character of Centralville's historic waterfront development patterns.

- Setbacks, corner treatments, and other design details should help to minimize the sense of bulk of structures, and ornamental and decorative elements appropriate to the urban and historical waterfront context are encouraged.
- The design of building roofs should help minimize the visibility of roof structures and penthouses normally built above the roof and not designed to be used for human occupancy.
- A proposed project should promote and enhance the quality of the pedestrian environment, by means such as: (a) pedestrian pathways connecting to the waterfront and, where appropriate, linking the waterfront and the bridge; (b) spaces accommodating pedestrian activities and public art; (c) use of materials, landscaping, public art, lighting, and furniture that enhance the pedestrian and waterfront environment; (d) pedestrian systems that encourage more trips on foot to replace vehicular trips; (e) other attributes that improve the pedestrian environment and pedestrian access to the waterfront; (f) appropriate management and maintenance of pedestrian access within the proposed project.

Zoning for the transitions

The UMU district in which the Gateway is located provides a great deal of flexibility to encourage new development in the Gateway area. This new development is likely necessary in order to define and assert Centralville's identity. We also feel, however, that there is a potential issue concerning the transitions from UMU to other zoning districts, particularly the Traditional Multi-Family (TMF) districts, as the table below demonstrates. This issue of transition from one zone to the next would also apply to other district boundaries, where the use and density allowed by zoning are substantially different.

The density allowed in the existing zoning at the Gateway district is potentially the highest among all the districts in Centralville. For residential use, the allowed number of units is capped by 1000 square feet of Land Area/ Dwelling Unit (LA/DU) (i.e., a 10,000 square foot parcel could support 10 units). For non-residential use, the allowed density is capped by a FAR of 4, but there is no height limit and dimensional guidance. The abutting TMF, in contrast, district has a much lower density. For example, the allowed number of units is capped by 2500 LA/DU, less than half

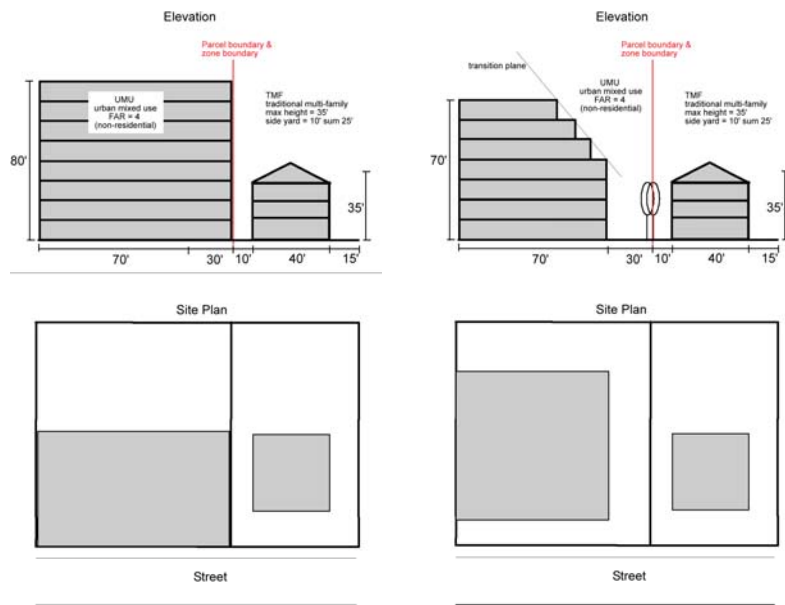

Figure 13: Transitional zoning diagrams focusing on setbacks, landscaping and height limits and sloping planes

that allowed under UMU, and the height limit for this district is 35 feet.

The image in the left column (above) shows that a new development on a large parcel in the UMU district could potentially reach eight floors, while the multi-family house in the abutting TMF is only three-stories high. A large non-residential development in the UMU district could have dramatic negative impact on the abutting homes in the residential district, such as casting shadows or creating noise. This extreme situation is unlikely to happen due to the city's strict parking requirements (for example, one space of parking required for every 900 square feet of retail area), but it is not impossible if parking can be arranged off site, put underground, or somewhere within the structure, for example.

We suggest providing additional guidance for the UMU district to smooth the transition from the UMU to other districts. These additional requirements would be applicable to the UMU parcels abutting residential districts only, such as those most

of found at the Gateway. The image in the right column (above) shows three techniques:

1. Require side yard setback to buffer new large non-residential development in UMU and existing residential buildings in other districts.
2. Require that landscaping help screen noise.
3. Set height limit for the UMU district or require a sloping plane to minimize its impact on neighbor in residential districts.

Such additional guidelines could be binding clause in zoning documents, or could be incorporated into design guidelines for citizen review groups.

Pedestrian Access/Traffic Improvements

Centralville is a strong neighborhood consisting of a business district on a main traffic artery surrounded by close-knit residential communities. The neighborhood streets provide for the mobility of residents and allow them to participate in a variety of daily activities. Cars, bicycles, and buses all use these streets to access the neighborhood. Streets of all sizes are also places where neighbors can walk and interact with the people and places that make their neighborhood special. There seems to be some resident consensus, however, that the transportation in Centralville needs attention. Residents fear for their children's safety in crossing streets, while drivers lament the gridlock at certain busy intersections. Our analysis addresses these concerns with particular focus paid to fostering a better pedestrian environment. Providing safe, comfortable, and directly accessible pedestrian walkways and street crossings throughout Centralville will increase the pedestrian activity and street life in the area.

The Gateway

The busiest roadway intersection in Centralville occurs at the intersection of Bridge Street, VFW Parkway, and Lakeview Avenue. This intersection defines the landscape at this important Gateway to Centralville. All three streets are wide and dominate the Gateway both visually and physically. During peak periods the Gateway expe-

periences high traffic volumes, while during off-peak periods lower volumes allow significantly higher speeds (see Appendix, Exhibit 1 for detailed counts). The design of the Gateway gives priority to vehicular traffic over other modes of travel as evidenced by right-turn slip out lanes, large turning radii, and wide travel lanes, which all allow for continuous traffic flows at high speeds. Pedestrian infrastructure at the Gateway is lacking despite the moderate pedestrian flows currently observed there. New, high quality pedestrian signals have recently been installed, though the signal phasing does not allow pedestrians to utilize them to their full potential. Additionally, poor signal coordination may be responsible for some of the congestion experienced here.

The intersection at Bridge Street and VFW Parkway is an important node for pedestrian trips between Downtown Lowell and Centralville. The short distance between Downtown and the businesses and residences of Centralville has historically strengthened the connection between the communities on either side of the river. Short walking distances between key areas of Centralville and Downtown combined with simple surface improvements will encourage and increase pedestrian activity around the Gateway. These kinds of improvements can promote trips from Downtown’s river edge to the businesses on Bridge Street, allow students to walk safely to school, and create a pleasant option for weekend trips to Downtown. The following recommendations for the intersection are intended to create a safe and comfortable environment for pedestrians and promote walking trips in Centralville.

Short-term solutions

The functional classification of the section of the VFW Highway that runs through Centralville is “urban principal arterial,” intended “to serve as the major conduits for interstate travel and Commerce” (2003-2025 Transportation Plan for Northern Middlesex Region). This classification is consistent with higher traffic speeds, no access to abutting properties, and continuous flows of cars. It is inconsistent with the desired pedestrian-friendly environment in Centralville, however. The option of discussing this classification with the Commonwealth should be explored, perhaps to change the designation to “minor arterial:” “to serve as links between major population centers within or between distinct geographic and economic regions.” If this seems infeasible, some alternative might be addressed to mitigate the problem.

The traffic signals at the Gateway intersection are designed to allow high traffic





Example	Alternative	Description
	Signs	Signs can be alerts to drivers to drive carefully and to be aware of pedestrians. Proper placement is important to get the attention of the driver
	Road Painting	Painting the roadway is a relatively easy way to alert motorists of areas that are used regularly by pedestrians as well as indicate preferred crossing sites to pedestrians.
	Lighting	Appropriately sized and designed lighting fixtures will not only alert drivers of pedestrians and provide for safer streets, but can also add charm to walkways.
	Police Enforcement	Police enforcement of driving speeds and acceptable behaviors will cause drivers to be more cautious and safe.

Figure 14: Short-term traffic calming techniques

flows between Bridge Street and VFW Highway. Flows crossing the Coz Bridge or following Route 38 are heavy and are given significant cycle time. However, significant back-ups in the peak periods are common, especially along Bridge Street. Specifically troubling is the conflict between northbound Bridge Street drivers and left turns from southbound Bridge to eastbound VFW which causes backups in both directions and frequent “near misses” between cars. In order to rectify these vehicular problems we recommend that the light be re-timed in order to more accurately account for the very directional nature of the peak period traffic flows. Isolating some of the high volume movements, like left turns, may also serve to ease congestion at the intersection and increase safety for drivers.

Of primary importance for the overall accessibility of the Gateway is the pedestrian signalization at the intersection. Currently, a pedestrian all walk phase is triggered by push buttons at all four corners. The push buttons are relatively new and are fully accessible to the deaf and are a great example of applied technology. Pedestrians are only allowed to cross legally after a full cycle of approximately two minutes has elapsed. Because this wait time is unacceptable to most pedestrians, they often jay-walk and cross when they are not supposed to. This is not only illegal, but it is very dangerous for pedestrians and should be discouraged. If possible, we recommend allowing pedestrians to cross parallel to moving traffic. The decreased wait time will encourage pedestrians to walk only during legal phases. This may not be possible, however, due to the complicated traffic patterns at the intersection. The pedestrian phase should also be extended to allow for seven seconds of walk time in addition to the time necessary for a slow-moving pedestrian to cross at 3.3 ft./sec. As development and pedestrian traffic increases around the Gateway, it might be beneficial to automatically include a pedestrian phase in the cycle.

Listed in the table (Figure 14) are other initiatives that can be taken in Centralville with relatively low levels of effort and cost. These solutions can be implemented while gaining support for and planning long-term projects that will have more lasting effects on mobility in Centralville. More information on carrying out transportation solutions can be found in the implementation section.



Figure 15: Traffic calming techniques: median is sufficiently wide to allow pedestrians to wait before crossing

Long-term solutions

The two-directional traffic on VFW Parkway is separated at the Gateway intersection by medians. On the east side of the intersection the median strip is low and thin and does not provide much shelter for pedestrians. However, the median on the west side is larger and contains a monument and more landscaping. These medians serve the dual purposes of providing a rest area for crossing pedestrians and of slightly calming the passing traffic. As such, the median strips on VFW need

to be improved to perform these functions better. Specifically, these medians should be re-built so that the waiting area is raised to provide protection from passing traffic. In addition, they should be widened to at least six feet wide to allow multiple pedestrians to wait there. Landscaping should also be investigated for these new larger median strips, ensuring that pedestrian and vehicular sight lines are not obstructed (Figure 15).

Lakeview Avenue meets the Gateway intersection at an odd angle at its northwest corner. At this point it is a one-way street accepting only northbound traffic and is lightly used, even during the peak hours. Because of this very low traffic there are questions about the necessity of keeping Lakeview open to traffic from all directions at this intersection. Several options are possible for regulating the inflow of traffic onto Lakeview Avenue including:

- Closing Lakeview off to all incoming traffic. This option would require construction of a cul-de-sac at the end of Lakeview to facilitate turnarounds. It would provide the most green space and would shorten pedestrian crossings. It would also slightly simplify the traffic patterns.
- Blocking right turns from Bridge Street onto Lakeview Avenue. This would increase pedestrian safety by shortening the crossing distance and would allow for the expansion of the sidewalk at the northwest corner.

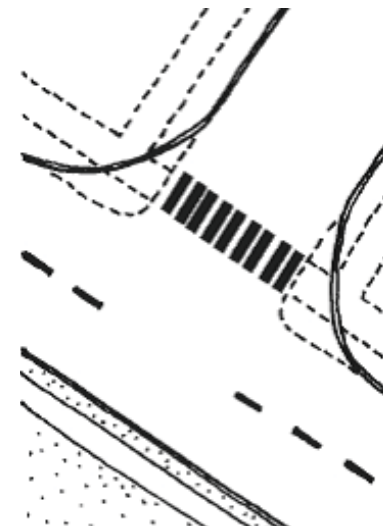

Figure 16 (Source: FHWA)

Either of these solutions could be implemented on a trial basis in order to determine the large-scale effect on traffic patterns before being implemented permanently.

Should right turns continue to be allowed onto Lakeview Avenue, then a main priority should be to improve pedestrian safety. The first method to achieve this goal would be to stop allowing right turns during red phases.

This is especially true since Massachusetts requires that during the pedestrian walk phase no cars are allowed to make any movement. Signs indicating this rule should be added at all corners of the Gateway intersection. In addition, pedestrian safety is threatened by speeding cars making the right turn onto Lakeview. Decreasing the turning radius at this corner would cause cars making that turn to slow down, in addition to expanding the pedestrian space available on the sidewalk (Figure 16).

Westbound traffic on VFW turning right onto Bridge Street have a dedicated right turn slip-out lane that allows for faster travel through the right turn at higher speeds without stopping for conflicting traffic or pedestrians. This is extremely dangerous for pedestrians trying to cross this travel lane. The goal at this corner would be to improve the pedestrian safety by slowing cars and allowing pedestrians to cross without danger from turning cars. There are several options that could be implemented in order to achieve these ends including (Figure 17):

- Install a traffic signal in the slip-out lane that stops cars during pedestrian walk phases. This improves pedestrian safety by requiring cars to stop when pedestrians are most likely to be in the intersection.
- Decrease the turning radius at the slip-out lane. This requires cars making the turn to travel at slower speeds and also expands the sidewalk at the northeast

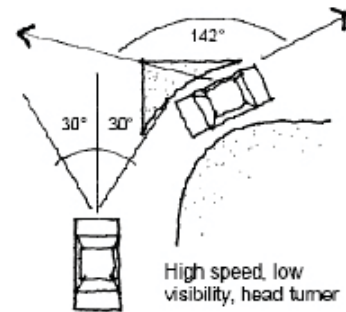

Current AASHTO Standard

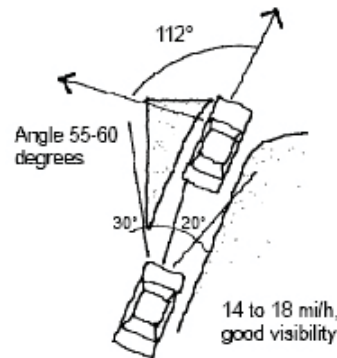

Recommended Design
1 mi/h = 1.61 km/h

Figure 17 (Source: FHWA)

corner of the intersection. This solution also improves visibility for drivers who are better able to see pedestrians who may be crossing in front of them.

- Create a right turn lane without a slip-out which requires drivers to obey the traffic light. Drivers would thus be required to stop on red lights. This redesign would shorten the pedestrian crossing distance in addition to increasing sidewalk space. This would also decrease the turning radius and slow cars during green phases.

More detailed studies of the impacts of these changes are necessary in order to determine which combination of improvements would be best for this corner.

The location and design of crosswalks is an important decision when designing for a pedestrian environment. Locating crosswalks properly indicates to pedestrians where it is safe to cross—and should therefore actually be safe. All four edges of the intersection require crosswalks that continue the existing pedestrian pattern. However, because of the significant restraints on the signal phasing, which makes it very difficult to allow pedestrian flows parallel to moving traffic, it may be necessary to implement another method for allowing pedestrians to cross two-ways (diagonally) without making any illegal and dangerous movements. To achieve this goal, we recommend adding two crosswalks diagonally across the intersection. In addition to providing a safe crossing for pedestrians, these very visible crosswalks provide a visual signal to drivers that the intersection is an important one for pedestrians and they should slow down and drive cautiously.

There are many possible designs for crosswalks that can be used at the Gateway. Colors, textures, grade changes, and patterns are all used to increase the visibility of crosswalks to make them safer and more attractive. Choosing among various options requires that the neighborhood consider many factors including price, ease of installation, maintenance requirements, replacement frequency, and design preferences.

VFW Parkway

The sections of the VFW Parkway that lie in between the Centralville neighborhoods and the Merrimack River create a barrier to pedestrian activity. High speeds



Figure 18: Alternative vision for the VFW Parkway at Read Street, connecting to Coleman Playground

on the Parkway combined with heavy flows of vehicles create dangerous obstacles for residents who would like to cross over the Parkway and go to the river or to Downtown. This situation is only slightly mitigated at the Bridge Street intersection, and nowhere else. In other words, there is no infrastructure or street enhancement to help people cross the VFW Parkway and access the resources on the other side.

A direct and safe access point for pedestrians is especially important to support any park improvements or event programming at Coleman Playground. While the park is only a stone's throw away for many Centralville residents, the lack of a crosswalk directly to the park causes neighbors to choose between two options for walking access to the park. The first option is a dangerous mid-block crossing across VFW without the aid of traffic signals or signs. The other option is walking down to the nearest crosswalk and then back towards the park, which could more than double the trip distance. Having to complete either one of these maneuvers reduces the viability of Coleman Playground as a destination. Pedestrian crossings that are safe and convenient for residents would therefore be a real asset to the community. For example, a safe crossing would be valuable at Read Street where many of the streets in the east part of the neighborhoods converge. Connecting Read Street to the west side of Coleman Playground would directly link the eastern neighborhoods in Centralville with the park. This crossing would increase the utility of Coleman Playground to residents whose use of the park would probably increase. More support for open space could, in turn, lead to better maintenance, more event programming, and future capital improvements.

The following alternatives for creating a VFW crossing were chosen because they

could work within the context of the VFW Parkway in Centralville. Some of the options are short term and could provide an effective and sometimes temporary aid to pedestrians. Other solutions will take longer to implement but their value to residents is also greater.

Short-term solutions

The short term street enhancements that would help to create a safe crossing on VFW Parkway, including changing the functional classification, road painting, signage, sidewalk lighting, and police enforcement, are detailed in the table under the Gateway transportation improvements section. This table shows examples of each of these improvements and describes the benefits that are associated with these enhancements.

Long-term solutions

Pedestrian signals (like the ones found on Bridge Street), combined with traffic lights, give both motorists and pedestrians exclusive rights to the roadway. Pedestrian signals should be designed so that they are audible and visible to pedestrians. Traffic lights can be set to allow crossings only when a pedestrian is present, or when traffic lights upstream are red.

Crossing islands (Figure 19) are useful tools for alerting drivers and pedestrians of crosswalks, providing a safe refuge for pedestrians, and adding room for landscaping. A path cut through the island will accommodate wheelchairs and bicycles. Mak-

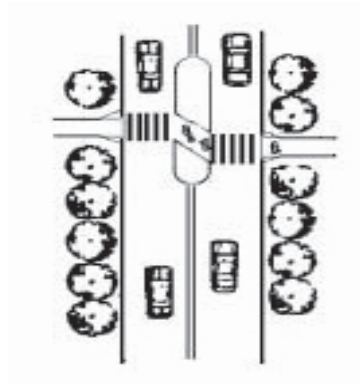

Figure 19 (Source: FHWA)

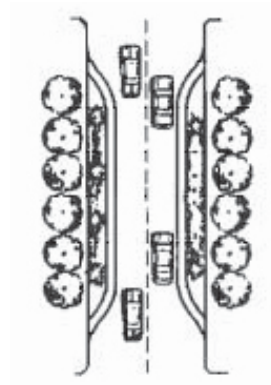

Figure 20 (Source: FHWA)

ing this path diagonal in the right direction forces pedestrians to view oncoming traffic before entering the street. These highly visible pedestrian islands will also prepare drivers to slow down and be aware of people in and near the street.

Installing chokers (Figure 20) onto VFW Parkway at the point of the crossing would also provide a powerful visual cue to drivers, alerting them to the residential area they are entering. Chokers on both sides of the roadway would slow down vehicle traffic and cause more careful driving. This desirable driving behavior will also be carried downstream as cars approach the Gateway. The extra space on each side of the VFW Parkway will also narrow the lanes, making crossing easier for pedestrians, and add room along the sidewalk for landscaping or street furniture that enhance the pedestrian's experience.

Textured crosswalks are a relatively easy way to alert motorists of areas that are used regularly by pedestrians and serve to indicate preferred crossing sites to pedestrians.

Implementation

Traffic calming measures

Larger construction projects like crossing islands, chokers and median build-outs can be tested in a temporary and cost effective manner. For example, sectioning off

Transportation Criteria for Bicycle/Pedestrian Improvement Projects (2003)

Condition	Transportation Criteria		Cost Effectiveness
	Mobility	Safety	
Magnitude of surface condition improvement	Number of new users	Effect on Bicycle Comfort Index	Cost per User
Magnitude of improvement of other infrastructure elements	Effect on travel time/access/connectivity for existing users	Effect on pedestrian safety	Cost per Linear Mile
	Consistent with State Bicycle and/or Pedestrian Plans		

Other Effects Criteria Used for All Projects

Other Effects Criteria for Transit Projects			
Air Quality/Climate	Service Quality	Environmental Justice	Land Use and Economic Development
Total Annual Tonnage Reductions in: VOC, NOx, CO2, Ozone, Particulates	Safety	Service to Minority or Low Income Neighborhoods	Serves an existing urbanized area
	Comfort	Rectifies Structural or Operational Barriers	Brownfields & Infill
	Customer Information	Burdens/Benefits to transit dependent neighborhoods	Population/Employment Served
		Addresses an RTP-Identified Issue	Existing Land Use Character
			Transit Supportive Zoning

Figure 21 (Source: Mass. Executive Office of Transportation)

the sides of the street where a choker is proposed with large planters is an easy and reversible adjustment to the roadway. These temporary solutions can be used to get feedback from the community, or to enhance the roadway until a more permanent transformation is possible.

Because both the VFW Parkway and the intersection at Bridge Street are state-owned and maintained, the process for improving the Parkway entails working with state authorized institutions. While this process does make changing the roadway and intersection more complex, it is certainly not impossible, and there are even

advantages involved in working with the state agencies.

To make changes to this roadway, a proposal should be made to the Northern Middlesex Metropolitan Planning Organization (NMMPO) for inclusion of the project into the Unified Planning Work Program (UPWP) and Transportation Improvement Program (TIP). Any work that receives federal funding must be included in these plans. Once a project has support from the NMMPO, the agencies that comprise the NMMPO will aid in technical support and procurement of funding for the project. This proposal should focus on the elements of the project which correspond to the criteria used to distribute federal funding. The two figures displayed above (Figure 21) show the criteria set up by the Massachusetts Executive Office of Transportation, and used by state MPOs when deliberating on proposed projects. Proposals to the NMMPO regarding Centralville projects should emphasize the alignment between many of the evaluation criteria and the project characteristics as well as mention the applicability of the new “Communities First” policy to these projects.

Funding

The following federal funding sources are applicable to the recommended transportation improvements and may prove useful in gaining support for these projects.

- *Highway Safety Improvement Program (HSIP)*: This program gives states the flexibility to appropriate funds to critical safety needs. Uses include construction and operational improvements to roadways.
- *Safe Routes to School*: A new program that funds both infrastructure and behavioral projects that support safe environments for children to walk or bike to school.
- *Surface Transportation Program-Enhancements (STP-E)*: Enhancement funds are federal monies for non-traditional transportation projects such as bike paths, pedestrian projects, streetscapes, historic restoration of transportation structures, etc. Transportation enhancements are funded with 80% federal monies matched with 20% state monies. In addition, the Commonwealth requires project applicants to provide a 10% overmatch. Projects are selected through a competitive process.
- *Congestion Mitigation Air Quality (CMAQ)*: Programs and projects funded under this category must contribute to the attainment of National Ambient Air Quality

Standards (NAAQS) or must be included in the State Implementation Plan pursuant to the Clean Air Act of 1990 and subsequent amendments. These funds may be utilized for both roadway and transit projects. These are 80% federal funding requiring a 20% state match.

- *Recreational Trails*: This program is aimed at developing and maintaining trails for recreational purposes. Because one of the major motivations for the proposed improvements would be to provide access to recreational trails along the Riverway, these projects may be eligible for this type of funding.
- *Scenic Byways*: Projects on highways designated as National Scenic Byways, All-American Roads, America’s Byways, State Scenic or Indian Tribe Scenic Byways that are of outstanding scenic, historic, cultural, natural, recreational, and archaeological qualities can apply for technical assistance and grants under this program.

Short Term Solution	Cost
Changing Functional Classification	Staff time
Signs	\$50 per sign
Road Painting	\$100 for a regular striped crosswalk, \$300 for a ladder crosswalk, \$3,000 for a patterned concrete crosswalk.
Lighting	Varies depending on fixture type and service agreement with local utility.
Police Effort	Redistribution of Policing Resources
Change Signal Timing	Staff time

- Total cost for long-term Gateway recommendation: \$162,000 - \$366,000
- Total cost for long-term VFW Crossing recommendation: \$56,650 - \$178,500

Riverway Open Space

The area along the Merrimack River in Centralville represents one of the neighborhood’s largest tracts of open space. The city owns approximately 170,000 square feet of space along the river, with another approximately 100,000 square feet owned by the state. About 50 percent (135,000 square feet) of this public space can-



not be developed, as it exists in long, thin parcels within the river's flood zone, and currently hosts (together with about 60,000 square feet of non-improvable private land) a poorly maintained and overgrown walking path. The rest of the Riverway's public open space, about 143,000 square feet, is also currently under-used and under-maintained. Abandoned tennis courts, overgrown trees, and a lawn with stunning views of Downtown Lowell make up what was formerly known as Coleman Playground. Little Varnum Park, at the southeastern corner of Bridge Street and VFW Parkway (as discussed above), is currently overwhelmed by overgrown trees and parked cars, and is unable to serve as a rest or viewing area for those making the trek to Downtown. The dangerous crossing across VFW Parkway to reach this public open space is likely the cause of this lack of use and attention, which has led to further disinvestment and the encroachment of socially undesirable behaviors.

Bridging this gap, however, will be worth the effort: the open space on the Riverway is unique within the City of Lowell, and even the Commonwealth, in terms of its size, orientation, and development potential. Few places can match its views of the river and of Downtown, and Centralville has no other parcels of publicly-owned open space of comparable size. This can become a space that offers activity and amenity for its potential users. It is also important for the city to have a plan for its open space as development pressures along the Riverway parcels increase.

Coleman Playground



Figures 22 and 23: current conditions; one alternative vision for Coleman Playground (above)

Coleman Playground consists of approximately two acres (three acres if the property along the river that is owned by the Church of the Nazarene is included) that is virtually unused by Centralville residents. The area consists of two abandoned tennis courts, an expansive lawn with views of Downtown, and dense overgrowth that currently serves as shelter to homeless individuals.

Given adequate pedestrian access across the VFW Parkway—a minimum requirement for this park's success—Coleman Playground has the potential to become a beloved park in Centralville and Lowell. Potential interventions range along a broad spectrum of cost and intensity. With parking on site relatively easily accommodated by converting the tennis courts to parking (or sharing the lot of the Church of the Nazarene), Coleman Playground could relatively quickly host a variety of im-

proved uses. Simple maintenance, perhaps with neighborhood cooperation, could trim back the growth and make this space more accommodating and comfortable to picnickers and pick-up ball games. Such maintenance and promotion by the city could likely encourage Centralville and Lowell residents to rediscover this unique park and use it in a variety of ways, without any major capital improvement expenditures by the city on open space amenities.

Additional investment and intervention, perhaps as real estate at the Gateway continues to develop, could turn Coleman Playground into one of the city's most interesting parks. The neighborhood and city should engage in community visioning and planning for this space, and work toward realizing one of a variety (or some mix thereof) of unique plans:

- In contrast to the industrial uses that dominated the river in year's past, Coleman Playground could play a role in educating residents and visitors about the role of the river and its watershed in New England's ecosystem. The open space could serve as a demonstration project for the ecologically-sound treatment of Centralville's runoff water, for example, or become a more "natural" waterfront that has long ceased to exist in the city. By following a nature trail, visitors could learn more about their area's natural flora and fauna, and be able to see native waterfowl and other wildlife.
- The relatively steep slope from Coleman Playground down to the water's edge suggests that this space could host a simple amphitheater. A stage at bottom, backing into the shore line and with the river and Downtown's mills as backdrop, could be used for community performances of plays or music, or as a gathering place when not being used for formal activities. With the long mill building across the river serving as the screen, this site also has the very unique potential for hosting outdoor film presentations. Other cities have made effective use of similar buildings for such public events, often sponsored by a local company or organization. This concept reflects the great range of possible public events that could be hosted by this unique facility, and that would add character and vibrancy to the Riverway.
- A relatively simpler intervention might be to develop more formal picnicking grounds and barbecue areas in Coleman Playground. The views of Downtown and the proximity to the river could make this type of use highly successful in this

area. Centralville's density, moreover, suggests that many residents, particularly those from lower income groups, likely lack private open space and therefore have a need for public space in which they can gather with family and friends.

- Again, a lack of private open space for many Centralville residents could translate into demand for public community gardens. Community gardens offer small plots to residents for no charge (usually distributed by lottery or waiting list), which gardeners can use to grow fresh fruits, vegetables, or flowers. Coleman Playground has sufficient space for a moderate-sized public garden, which would provide a variety of services to the community, including an attractive use of space, self-maintenance, fresh produce for those not otherwise able to afford it, and activity for those without a great deal of property.

In short, Coleman Playground should reflect the needs and desires of Centralville residents, its most obvious patrons. We note also that, though residents throughout Lowell report a shortage of tot lots for the city's youth, Coleman Playground, because of the need to cross fast-moving traffic for the foreseeable future as well as its proximity to fast-moving water, likely would not be an ideal location for a tot lot. It has the ability to host an array of other important and unique uses, however, that could make it a great amenity for the city and neighborhood. Ensuring the safety and promoting the comfort of those who access and use the site should be a top priority.

River Path

The path along the Merrimack River is a tremendous amenity for the community. It presents a beautiful, uninterrupted trail for joggers and sightseers and provides perfect views of the mill buildings across the water. This resource, however, is likely under utilized due to: 1) its lack of connections to other paths or to infrastructure, or 2) a perceived lack of safety along the trail (Figures 24 and 25).

Providing better access to the river path is an important intervention. As the proposed plan for the area shows, in our area of focus along the edge of Centralville, there are potentially 4 or 5 new or improved access points to the river path. Better access to the trail will increase pedestrians' ability to use it and will enhance their perceived and actual safety while on the path.



Figure 24: Current access to the River Path (above)



Figure 25: current state of the River Path (right).

Further contributing to feelings of insecurity along the river trail is its overgrowth. Maintenance along this linear park system can be difficult, but could be improved by involving community groups and interested citizens. Clearing overgrowth and improving lines of sight in and out of the path would invite new groups of people to use the path that may currently feel intimidated.

Improving access to the river path and clearing the growth along it represent both short- and long-term interventions that will greatly increase this amenity's value.

Waterfront

Clearing the plant growth directly along the water's edge could do much to reintroduce citizens to the river, but more intensive developments could make the Merrimack River a true destination in Lowell and a unique urban waterway in the region. As the country's rivers are cleaned up after decades of industrial use, many cities are rediscovering their significant aesthetic and recreational appeal. A waterfront becomes a draw for anglers, for boaters or kayakers, or simply for onlookers or couples on dates.

Developing a waterfront in Centralville, perhaps utilizing the space behind existing buildings on the south side of VFW Parkway (on land currently controlled by the Commonwealth of Massachusetts, therefore reflecting a need to cooperate with the state), is a potential long-term project that could become a great amenity for the neighborhood and the city. Landscaped or hard surface open space developed as part of the future redevelopment of 31 First Street could provide an important connection to the river for the neighborhood. This intervention would open up the river's edge and the river itself to a variety of uses, as well as to views along the water. Such uses include:

- A boardwalk surface for strolling or fishing;
- A dock for small boats;
- Park space designed to connect the water to activities at Coleman Playground, such as through environmental education displays;

- Seating areas for observers of water activities, or events taking place (such as a film screening) across the river.

Implementation

Throughout this section we have highlighted a number of different open space interventions to enliven the Riverway as a destination, to establish better physical and visual connections to the River and to Downtown, and to improve safety and comfort in the area. In our view, the most important intervention along the Riverway could possibly be relatively easy and inexpensive: improving maintenance, particularly through the trimming of overgrowth. Cooperation and participation by community and citizen groups in this effort not only saves costs, but also mobilizes an important part of the community to have care and appreciation for this large swath of public open space. Citizens themselves can start to make this an active, safe place.

Closely following the issue of maintenance is the importance of access, both across VFW Parkway (as discussed in the traffic section of this chapter) and along the river. For the Riverway to succeed as an active place, citizens must have confidence in accessing it. Access to the River Path, for example, is currently too difficult to locate or, once located, to negotiate, particularly for users with even minor walking difficulties. Improving the stairways down to the path (and adding ramps) and providing new access points must be a top priority. As shown on our overall open space map, new and improved access points should be established at Varnum Park, behind the Church of the Nazarene, at a proposed Amphitheater, and at the far east side of Coleman Playground.

The remaining priorities largely depend on how Centralville and the City of Lowell envision their use of the open space. We highly recommend clearing non-indigenous, overgrown flora and opening views from Centralville to the river and to Downtown, as well as instituting policies to curb use of the space for informal dwellings. Beyond these two important interventions, the City of Lowell should ensure that the open space along the river becomes an amenity that fits the current and future needs and desires of a broad spectrum of users from Centralville and the rest of the city. Possible sources of funding beyond the municipal budget include (this is just a sample list of public funding sources):

- The NOAA *Open Rivers Initiative* (ORI): Provides funding to improve river habitats, such as through removing dams or other barriers for fish, particularly diadromous fish. The National Oceanic and Atmospheric Administration looks to fund projects that have broader educational, cultural, or social benefits. For more information: <http://www.nmfs.noaa.gov/habitat/restoration/>.
- *Learn and Serve America*, Corporation for National and Community Service: Funds development of community service programs for youth in a wide variety of areas, such as community development, education, agriculture, and natural resources. The city could not directly apply for funding under this program, but nonprofit (including universities) city partners could do so. For more information: <http://www.nationalservice.org/about/programs/learnandserve.asp>.
- *Technical Assistance to Develop and Implement Conservation Programs*, Natural Resources Conservation Service: Administered by state offices of the Natural Resources Conservation Service, these grants can be used to assist city governments in planning, designing, implementing, monitoring, and evaluating fish and wildlife habitat development projects (we are not aware of whether this program is currently in force in Massachusetts). For more information: <http://www.nrcs.usda.gov/programs/>.
- *Fish Passage*, U.S. Fish and Wildlife Service: Funding to improve fish passage in waterways; funds a variety of different types of water projects. For more information: <http://www.fws.gov/fisheries/>.
- *Grants for Arts Projects*, National Endowment for the Arts: Provides funding for various types of arts activities, including community art programming along the Riverway. For more information: <http://www.nea.gov/grants/apply/index.html>.
- *Self-Help Conservation Land Acquisition Program*, Massachusetts Executive Office of Environmental Affairs (and the similar Urban Self-Help Program): “Provides grant assistance to city and town conservation commissions for the acquisition of open space for conservation and passive recreation purposes.” For more information: <http://www.mass.gov/envir/dcs/selfhelp/default.htm>.
- *Recreation Trails Program*, Massachusetts Executive Office of Environmental Affairs: “Provides funding for construction and improvement of publicly accessible

recreational trails.” For more information: <http://www.mass.gov/dcr/stewardship/greenway/grants.htm>

- There are a variety of grant programs covering waterways, trails, open space, and conservation available from the Massachusetts Executive Office of Environmental Affairs. See http://www.mass.gov/envir/grant_loan/ for more information.

Implementation and Priorities

Making the Riverway an active destination, vibrant connection, and safe and comfortable place will require addressing it comprehensively. Traffic improvements should support open space development; new buildings should complement open space; zoning should be drafted to prevent undesired development, etc. As any improvements will necessarily be tackled in phases, however, it is important to prioritize the interventions. One way to do this is by assessing the relationship between the proposed interventions’ degree of beneficial impact on the Riverway with its ease of implementation (in terms of both cost and effort required to implement).

Figure 26 graphically illustrates this relationship for the four broad categories of interventions we have proposed, and suggests a rough list of priorities for the city in implementing these projects. It is important to note that this simple analysis takes into account the possibility of implementing short-term or partial solutions for each type of implementation. This factor directly influences the outcome, as some interventions, such as Open Space, have a wide variety of potential projects with varying degrees of difficulty, while others, such as Real Estate Development, basically involve only one type of process.

Open Space, largely because of the variety of options the city could pursue to dramatically improve this aspect of the public realm, therefore becomes our recommended top priority regarding efforts to improve the Riverway. As noted above, even relatively minor projects, such as better maintenance and clearance of overgrowth, could make significant improvement to this space, while larger ones, such as developing a waterfront, could dramatically improve the level of amenity in Centralville.

Zoning and other regulations to protect Urban Design are second on the proposed list of priorities, largely due to their relative ease of implementation. As with any

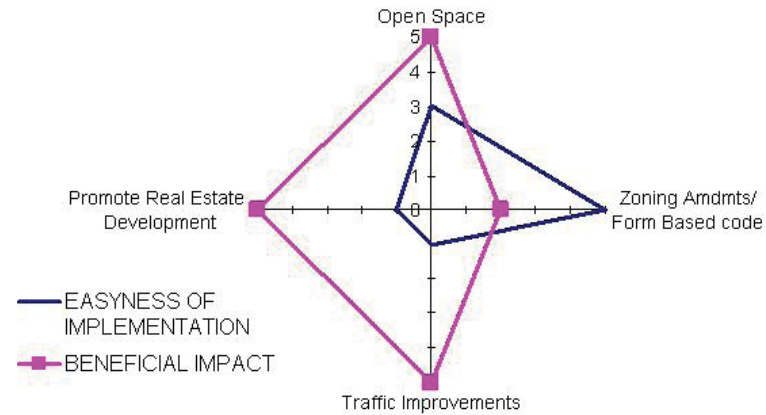

Figure 26: Implementation diagram

regulation, outcomes are always somewhat uncertain until the matter is applied in the built environment; passing definitive judgment on their expected beneficial impact is therefore difficult. As we explain above, however, certain aspects of the current zoning should be addressed in order to promote an enhanced character for development along the Riverway. Though pushing legislative changes or amendments through the proper channels can be difficult and time consuming for city officials, this method is far less expensive than other options.

Traffic and Pedestrian Improvements are extremely important to improving connections to and from Downtown, as well as in making the Riverway an active destination. This area’s safety and comfort depends on providing good passage to the pedestrian as well as ensuring the smooth flow of traffic. Implementing traffic calming strategies, primarily because of city-state jurisdictional issues, might prove to be very difficult, however. Still, even less intensive measures would dramatically improve the transportation experience at the Riverway.

Real Estate Development also has a potentially huge impact on the long-term character of the Riverway. The buildings developed on the site will have a lasting im-

pact—positive or negative—on the quality of this space for years to come. Beyond land use regulation – which has its limitations – or acting as the actual developer, however, the city has very little direct impact on what ultimately gets built. Despite the importance of quality real estate at the Gateway, we suggest that the city therefore focus its priorities on matters more under its direct control. We have the confidence, moreover, that this will help inspire quality, pedestrian-oriented development at the Gateway, and along the Riverway.



EVENT PROGRAMMING

Center on Centralville

According to public opinion research conducted by the City during its master planning process, residents rank Lowell very highly for its planning of public events and citywide festivals. Lowell is widely known for its mill-focused National Park and annual Folk Festival, and the City, National Park Service, and other local groups sponsor a number of other successful city-wide events.

However, our research indicates that there are very few public events held in the Centralville neighborhood. The National Park Service limits its activities to the Downtown area and the Industrial Revolution. The City itself holds no events in Centralville other than organized sports like soccer and baseball. According to the president of Lowell Celebrates Kerouac!, the group sponsoring that annual festival, occasionally there are tours or events in Centralville, the birthplace of Jack Kerouac, but this is not a regular occurrence.

Given this current lack of organized events in Centralville as well as a lack of regular contact between residents from different parts of Centralville, we have focused on generating ideas for very local events in shared spaces that target bringing the residents of Centralville together and enhancing community pride.

Centralville Community-wide Events

CentralvilleWorks!

We propose that a number of community-wide *CentralvilleWorks!* days be held every three to four months at different locations in the neighborhood throughout the year. These events would bring the community together around specific beautification or community art projects that improve the neighborhood, serving the dual purposes of gathering volunteer labor for improvements and uniting the community around a shared resource. Without a strong collective community identity upon which to build, the community is most likely able to rally around the shared space and place of the neighborhood.

Some locations which we propose for the *CentralvilleWorks!* days include:

1. The Riverway. In another section of this report, recommendations include enhancing access to the Riverway and removing some of the trees which block views of the river and Downtown. Perhaps a Volunteer Beautification Day could be organized around the clearing of underbrush, fence repair, and other improvements to the existing path along the river. (Figure 1)
2. The Reservoir is a unique asset of the Centralville neighborhood. While it has beautiful views, some benches, and a walking path around the reservoir, some consideration of new landscaping or park furniture could further enhance this as an open space resource. Attention from volunteers as well as professionals can help to give this open space more of a sense of place. (Figure 2)
3. Moulton Square has already benefited from beautification efforts by the City and the community. As a key central open space that is heavily utilized by residents, Moulton Square (including Keenan Playground) could be further enhanced through efforts such as a community art project or additional street furniture and plantings. (Figure 3)

These are merely suggestions that should be further developed by residents. Perhaps they know of particular residential streets or nodes that need extra care.

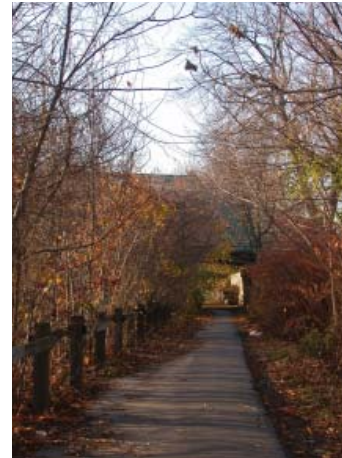

Figure 1: The Riverway.



Figure 2: The Reservoir



Figure 3: Moulton Square

A Jack Kerouac Trail

Birthplace of the writer who inspired the Beat Generation, Centralville could create more opportunities to integrate the life of Jack Kerouac into the neighborhood. While the National Park Service does show a movie about Kerouac in Lowell and has information about him in the Visitor Information Center, it currently has little connection to Centralville. However, a website called “Jack Kerouac’s Lowell” has published self-guided tours of Downtown, Centralville, and Pawtucketville online and in hard copy, available at the Visitor Information Center.

We recommend that a heritage trail be created that traces the early years of Kerouac’s life in Centralville. This trail would not only provide assistance for self-guided tours for Jack Kerouac admirers, Beat Generation fans, and other visitors and tourists but would also provide a spatial connection to Kerouac for residents of the neighborhood (see Figure 4).

A plan for the trail would include:

1. A marking of the trail on the sidewalk like the Freedom Trail in Boston. While it might eventually be marked in pavers or brick, a colored painted line would be sufficient and more cost-effective. The trail would link important locations in Centralville from his life and books, and commemorative plaques would be placed at these locations. Currently, a plaque marks only the house of

his birth. 2. A map and poster of the trail. Copies of a user-friendly map would be made available at the Visitor Information Center in Downtown Lowell, local libraries and community centers, and other places of congregation. If the trail followed “Jack Kerouac’s Lowell: Centralville,” there is an existing set of maps already available at the Visitor Information Center.

Commemorative plaques along the trail might include:

1. Kerouac’s birthplace at 2 Lupine Road in Centralville.
2. St. Louis de France Church, where Kerouac was baptized. While this parish was closed by the Archdiocese in 2004, masses continue to be held and the congregation still functions as a community.
3. St. Louis School, which Kerouac attended. Sister Irene, the principal of St. Louis School confirmed that Kerouac fans and tours occasionally drop by the school.
4. 34 Beaulieu Street, family home.
5. 320 and 240 Hildreth Street, family homes
6. 66 West Street, family home

The trail might be extended later to connect to significant locations in Pawtucketville and Downtown. Such significant locations include: the Jack Kerouac Commemorative Park, the Pawtucketville Social Club which his father managed, family homes in Pawtucketville, Lowell High School, local pubs which he frequented, and Edson Cemetery. However, while links to other Kerouac-significant neighborhoods would eventually be appropriate, our focus here is to emphasize Kerouac’s significance to the Centralville neighborhood and its residents.

The trail might also be an opportunity to commemorate the contributions and history of the French and French-Canadian immigrant community in the Centralville neighborhood.



Figure 4: Apossible Jack Kerouac Trail around significant places in Centralville.

Maximizing Use of Centralville's Open Space Assets

Open Space Opportunities

As mentioned above, the river and reservoir are two special resources in the Centralville community. Other sites with open space that are centrally located in the neighborhood with potential for community events include Moulton Square/Keenan Playground and the St. Louis parish site. These open spaces could be maximized more fully with the planning of the following events and/or improvements.

1. The River and Riverway are currently underutilized due to limited access, trees in need of pruning, and concerns about safety. If the walkway along the river were cleaned up and access were improved, it could be a site for activities during RiverFest or other events. At some locations, the pathway has ample room for small festival booths or event tables in addition to space for walking. (Figure 5)

2. The Reservoir is unique to the Centralville neighborhood (Figure 6). As outlined in a previous section, we recommend that it be enhanced in the following ways:

- a. Increase accessibility and a sense of place through improving its function as a place for science education, individual exercise (walking/jogging), and relaxation.
- b. Enhance visibility and visual aesthetic through landscaping and park furniture improvements.
- c. Ensure safety of users (sledders) and water through improved signage.
- d. Build connections to the rest of the community through new signage, greenmapping signage throughout the neighborhood, and street trees leading to the Reservoir.

3. St. Louis Parish. Though closed by the Archdiocese of Boston in 2004, masses are still held at this church, and the school continues to operate. The site of St. Louis includes a large open field and parking lot that have the potential to be



Figure 5: At some locations, the pathway along the Riverway has ample room for small festival booths or event tables in addition to space for walking.



Figure 6: The open space at the Reservoir is unique to the Centralville neighborhood.



Figure 7: Open space at St. Louis parish might be used for community events.

used for community events. We spoke with the principal of the school, and she readily agreed that the community could use the space for events or activities when mass and school are not in session. As there are few stores nearby with fresh produce, a farmers' market could provide a needed amenity to the neighborhood. While the financial viability of a farmers' market at this location has not been analyzed, this would be an ideal central location within Centralville with ample space for parking and farmers' booths. (Figure 7)

St. Louis could also be a location for a neighborhood-based festival, such as a cross-cultural food fair. With increasing numbers of immigrants with different cultural backgrounds, the neighborhood should maximize opportunities to learn about and share in other cultures. A cross-cultural festival, perhaps focused on food or culture, would enable many subgroups within Centralville to feel invested such an event.

Greenmapping of Centralville's Open Space Assets

With the reservoir and the river, Centralville has access to open space opportunities that many other neighborhoods lack. We are recommending that the City encourage the planning of events and activities in these spaces that are focused on the neighborhood residents. Though most residents we spoke to knew of and utilized Moulton Square and the Reservoir at least on occasion, we perceive that the open

spaces could be publicized to a greater extent.

The Green Map System is a "locally adaptable, globally shared framework for environmental mapmaking" (Source: www.greenmap.com). It encourages communities to design maps of environmental resources through a locally-driven design process. We encourage the schools in Centralville to drive such a process. A greenmapping exercise led by students would gather local knowledge of environmental and cultural resources; maps could then be distributed and placed on signs around the community, thereby educating residents about the locations of open spaces and other community assets. Both the process and the product of a greenmapping exercise would benefit the Centralville community. (Figure 8)

Implementation through Connections and Partnerships

City staff could organize these events and community activities, but we believe the activities would be most effective if they were organized by a group of representative residents who could encourage their friends and neighbors to participate. If appropriate, the City could catalyze the process by designating or nominating representative community members to work on a task force that would organize the first events. In addition, churches, schools, and organizations like Keep Lowell Beautiful could also be potential partners in these endeavors.

Community Institutions & Potential Partners

Centralville is fortunate to have a rich set of community institutions. With four public schools, two parochial schools, and numerous churches, there are numerous existing community resources on which to draw—both in terms of mobilizing people and utilizing space. For example, while the St. Louis parish was officially closed in 2004, masses are still held there twice weekly and the school still serves as a center for the congregation. The St. Louis parish site also has a sizeable open space which can be used for community events or activities.

In addition, the Patrick J. Mogan Cultural Center is a potential partner for the community. Under the umbrella of the National Historic Park, the Mogan Cultural Center cosponsors many ethnic festivals and cultural events in Lowell and is eager to partner with individuals and organizations with new ideas for events and other projects. The Mogan Cultural Center has already partnered with some Centralville

PRELIMINARY VIEWS OF THE SEATTLE GREEN MAP, VERSION 2005

THIS MAP IS INTENDED AS AN ALTERNATIVE TO THE INTERACTIVE ONLINE MAP. THIS MAP WILL BE ENHANCED IN THE DAYS FOLLOWING WORLD ENVIRONMENT DAY, INCLUDING THE ABILITY TO IDENTIFY SITES.



Figure 8: An example of a “Green Map” from Seattle.

organizations, including an African dance group and the Centralville Neighborhood Partnership. The Mogan Cultural Center has indicated that it is open to new partnerships and new ideas for events, and it might be an ideal co-sponsor for a cross-cultural event in Centralville.

Connections to City-wide Events

As noted above, the City of Lowell, the National Park Service, and community groups plan a number of well-known and successful festivals and public events. From the Lowell Celebrates Kerouac! annual weekend-long festival and the Lowell Folk Festival to open studios, Riverfest, and many other city-wide events, Lowell provides a variety of opportunities for residents and visitors to enjoy the city and its culture. However, most of these events are centered on Downtown. We believe there is an opportunity to extend some of them over the bridge and into Centralville, particularly those events and activities associated with the Merrimack River and Jack Kerouac. Working with the Lowell Celebrates Kerouac! organization to make Centralville a regular event location for the annual Kerouac weekend would be a first step.

To increase pride of place within the Centralville community, we recommend that the City partner with organizations planning these popular events and bring some activities to Centralville. The river, the reservoir, and other open spaces in Centralville are assets that many other neighborhoods do not have available to them, and they should be used to their fullest extent.

CONCLUSIONS [ACDODGE]

Tue facillam dunt exero odolobore ming enissi bla consequis nissed te facilla orpero commodi pissisis at. Feum iliquipsum diamcoreet, quissim veliscing eugue dolore feui tem etue ming et verit, quisi tio cor iliquat dit wis amet, venim iurero ea feugiat augiamet lut wisl iure te tatie faccum nonsequat. Ut lore dit la feuisl ea feugait, suscipit, sumpsandiat, vel exero ecte moluptat nisi.

Rem dolortie magna at. Andre modignis deliquat.

Cin vel dolut at, sisit aliquis dolor sis alis euis nostin erat luptat adio cuipsum cincipit adit auguer at laorting eugait iustrud ectet velent in hent wissit aut utpatue dolore digna ad magnisi.

Met in hent nos ad dolum volorer aessit non ver sequis alis eu feum zzriure volorperate feugiamcorer suscinim in exer sum zzriliquisim aciliquis nullum zzrillut nit augiat volor ipsummy nim doluptatum illa feu faccum volor ipit venim il utem del

APPENDIX–RIVERWAY

Exhibit 1: Riverway Traffic Counts

Exhibit 2: 318 Bridge Street Parcel Financials

Exhibit 3: 15 First Street Parcel Financials

Exhibit 4: Development and Construction Costs

Exhibit 1: Riverway Traffic Counts

Movement:	Hourly Traffic	
	AM Peak	PM Peak
VFW Eastbound	736	556
VFW Eastbound to Bridge St. North	16	32
VFW Eastbound to Bridge St. South	84	84
Bridge St Southbound	464	344
Bridge St Southbound to VFW Eastbound	344	344
Bridge St Southbound to VFW Westbound	64	44
Bridge St Southbound to Lakeview (West)	0	24
Bridge St Northbound	236	448
Bridge St Northbound to VFW Westbound	100	44
Bridge St Northbound to VFW Eastbound	48	100
Bridge St Northbound to Lakeview	16	188
VFW Westbound	440	868
VFW Westbound to Bridge St Northbound	236	368
VFW Westbound to Bridge St Southbound	192	104
VFW Westbound to Lakeview	84	208

Exhibit 2: 318 Bridge Street Parcel Financials

Development of "Tavern" parcels (318 Bridge St)

Land (sq ft) = 27,088

WITH EXISTING ZONING	
Zoning Limitations	# dwelling units
Limitation due to Parking	25
Limitation due to Land Size	27
FAR limit of 4 (sq ft)	108,352

Program	Footprint sq ft	Revenue sale or \$ yr psf	Bldg Cost
ground retail	13177	13.2	\$ (2,371,860)
2nd Fl condos	13177	\$ 190,000	\$ (1,976,550)
3rd Fl condos	13177	\$ 190,000	\$ (1,976,550)
4th Fl condos	13177	\$ 175,000	\$ (1,976,550)
		land =	\$ (1,250,000)
Grade Parking	13,911	200	\$ -
Total Bldg	52,708		\$ (9,551,510)

	AS OF RIGHT	w/ RECOMMENDED PARKING VARIANCE
Dwelling units	25	36
Parking Spc	70	70
Revenues	\$ 8,499,806	\$ 10,184,806
Gain / (Loss)	\$ (1,051,704)	\$ 633,296

DEVELOPMENT
ECONOMICALLY NOT
VIABLE BY PRIVATE
DEVELOPER

Exhibit 3: 15 First Street Parcel Financials

Optional Development of Autoparts Warehouse: +18 condos & Sports Club

Land	53,773						
Exist Bldg	25490						
Total FAR	215,092						
Actual FAR	0.53	39,600					
Building A	sq.ft	apt.units	parking	rental \$/yr/psf		Revenues	Bldg.Cost
Sport Club	8,000		13.3	10.8 \$		1,234,286 \$	(1,480,000)
restaurant	3000		5.0	15.6 \$		668,571 \$	(555,000)
2st Fl apartmt	7,075	4	8.8	200,000 \$		800,000 \$	(1,061,250)
3st Fl apartmt	3,150	2	4.4	200,000 \$		400,000 \$	(472,500)
Building B							
1st Fl apartmt	6,125	4	8.8	200,000 \$		800,000 \$	(918,750)
2st Fl apartmt	6,125	4	8.8	200,000 \$		800,000 \$	(918,750)
3st Fl apartmt	6,125	4	8.8	200,000 \$		800,000 \$	(918,750)
			land =			\$	(2,481,403)
Possible parking	12,000		60			\$ 1,200,000	\$ (72,000)
Landscape	2,173					\$ 6,702,857	\$ (8,878,403)
						\$	(2,175,546)



 DEVELOPMENT
 ECONOMICALLY NOT
 VIABLE BY PRIVATE
 DEVELOPER

Exhibit 3: 15 First Street Parcel Financials

Development of Autoparts Warehouse: Centralville Indoor Sport Center

SUMMARY

Land = 53,773 Parcels ID: 0177 2325 0015 0000 & 0177 2327 0031 0000

Program	dimmmensions (feet)		sq ft	rental \$ yr psf	Revenues	Bldg Cost
Indoor Soccer	180	85	15300	15.8	\$ 242,152	\$ (1,836,000)
Sm Ind Soccer	154	85	13090	15.8	\$ 207,174	\$ (1,570,800)
Sm Ind Soccer	154	85	13090	15.8	\$ 207,174	\$ (1,570,800)
food & beberage / restaurant			3000	15.6	\$ 46,800	\$ (540,000)
Locker rooms & other			3000			\$ (555,000)
Parking	200		6,000	30		\$ (36,000)
	sfp space		53480		land value =	\$ (2,481,403)
					\$ 703,300	(\$8,590,003)

cap rate = 7%
 Revenue Value= \$ 10,047,143
IRR = 12%

Time (year)	Cash Flow
0	\$ (2,481,403)
1	\$ (6,108,600)
2	\$ 703,300
3	\$ 727,916
4	\$ 753,393
5	\$ 779,761
6	\$ 807,053
7	\$ 835,300
8	\$ 864,535
9	\$ 894,794
10	\$ 926,112
11	\$ 15,131,013

Three Indoor Soccer & Multi-Sports fields, plus other facilities for outdoor activities
 Development economically feasible with Internal Rate of Return of 12%
 Activation and enchancement of riverfront and Coleman Playground

Exhibit 3: 15 First Street Parcel Financials

Development of Autoparts Warehouse: Centralville Indoor Sport Center

INDOOR SPORTS PROGRAM INPUT TABLE																					
Schedule	Mo			Tue			Wed			Thursday			Frid			Sat			Sun		
	Big Field	Field 2	Field 3	Big Field	Field 2	Field 3	Big Field	Field 2	Field 3	Big Field	Field 2	Field 3	Big Field	Field 2	Field 3	Big Field	Field 2	Field 3	Big Field	Field 2	Field 3
morning	C			C			C			C			C			A	A	A	A	A	A
afternoon	A	A	A	A	A	A	A	A	A	A	A	A	A	A	A	B	B	B	B	B	B
evening	B	B	B	B	B	B	B	B	B	B	B	B	B	B	B	A	A	A	A	A	A

Youth League = A Adult League = B Events = C

	event ren	Gross revenue	Annual Prog Rev
weekly events =	5	\$125	\$625
weekly Youth =	54	\$125	\$6,750
weekly Adults =	42	\$125	\$5,250

Center to accommodate Youth League and Adult League, as well as various events
 Complements and provides infrastructure for outdoor activities and sports at riverfront
 Three Indoor Soccer & Multi-Sports fields, plus other facilities for outdoor activities

Exhibit 4: Development and Construction Costs

Development and Construction Costs

Expected inflation in all costs 3.50% per year

SITE COSTS

Driveways	\$3.40 /l.f.
Peripheral/Buffer Landscaping (Sod, Shrubs, sprinklers)	\$11 /gsf
Public Open Space	\$29 /gsf
Semi-Public & Private Open Space	\$26 /gsf
Demolition costs	\$7 /gsf

PARKING CONSTRUCTION COSTS

1 Struc. Below Grade 1	\$23,000 /car
2 Struc. BG 2	\$34,000 /car
3 Struc. AG	\$20,000 /car
1 At Grade Bitum.	\$1,200 /car
2 AG Conc.	\$1,800 /car
3 AG Cobble.	\$3,400 /car
4 AG Brick	\$3,000 /car

Structured Below Grade (up to 1 level below grade):
 Structured Below Grade (2 levels below grade):
 Structured Above Grade (on conventional foundations):
 At grade:
 Bituminous
 Concrete
 Cobblestone
 Brick

BUILDING CONSTRUCTION COSTS

Base Building (New Construction - includes shell, elevators, stairs and basic electrical, water, sewer, fire protection service; no mechanicals)

1 1 s	\$75 /gsf (assumes spread footings)
2 1-4 w/s	\$120 /gsf (assumes light piling fndns)
3 1-4 s/c	\$170 /gsf (assumes piling fndns)
4 4-8 s/c	\$230 /gsf (assumes piling fndns)
5 8+ s/c	\$270 /gsf (assumes piling fndns)
6 Rehab	\$70 /gsf

1 story steel bldg - 15% masonry (whse/retail shell)
 1 to 3-1/2 floor wood/steel stud frame; wood or Dryvit exterior
 1-4 floor steel/concrete; masonry & glass ext.
 4-8 floor steel/concrete; masonry & glass ext.
 8+ Steel/Concrete w/ stone veneer & glass
 Shell prep costs (rehab)

TENANT FIT UP (includes mechanical & electrical)

Sports Center	\$65 /nsf
Art Galery	\$100 /nsf
Retail	\$60 /nsf
Apartments - 2nd floor	\$30 /nsf
Apartments - 3rd floor	\$30 /nsf
Apartments - Afford. 10%	\$30 /nsf
Apartments - 4th floor	\$30 /nsf
Rental Hsg - Market	\$80 /nsf
Rental Hsg - Afford.	\$78 /nsf
Community Center	\$110 /nsf
Big Box Retail	\$30 /nsf

DEVELOPMENT SOFT COSTS

Architecture/Engineering	7.5% of hard costs
Legal and other Professional	6.0% of hard costs
Retail/Office/Lab Leasing	17.0% of annual rent roll
Residential Condo Marketing/Sales Commissions	5.0% of gross rent/sales
Property Tax	
Development Mitigation Fees to City	1.5% of total development costs
Overhead	5.0% of total development costs

CONSTRUCTION FINANCING

Interest Rate	6.00% annual, fixed
Term	24 months
LTV	75% value as of time = 36 months or when last phase is stabilized, whichever comes first
Loan to Cost Ratio	75% total costs (undiscounted gross costs)

(Required equity contribution to be paid out before first draw)

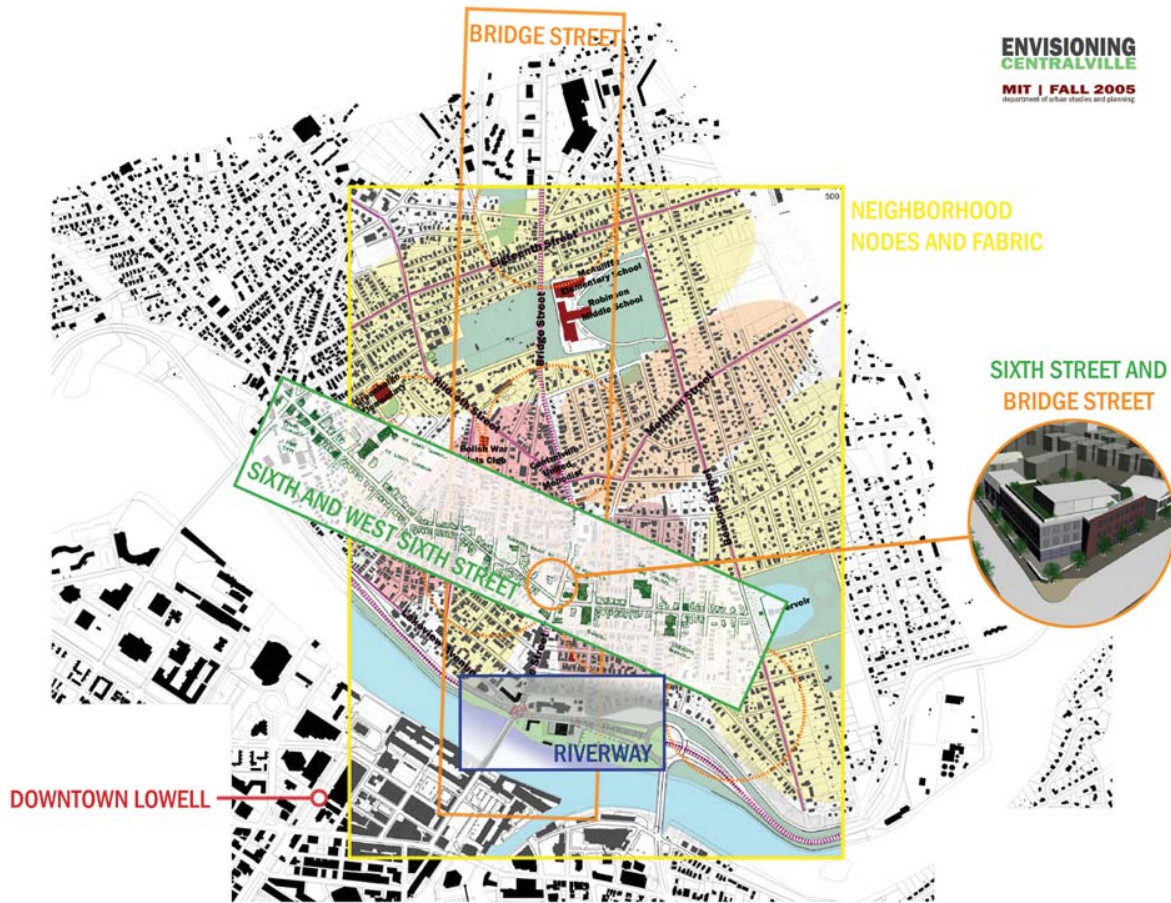



AFTERWORD

Students in “Community Growth and Land Use Planning,” a graduate level planning course offered in the Department of Urban Studies and Planning at MIT, have for more than two decades undertaken challenging planning projects, usually sponsored by municipal clients. This semester, our students have discovered that Lowell’s Centralville neighborhood is a place with many built and natural assets. But the greatest of these assets are its people. We wish to thank all those who have joined with us in the planning process for Centralville: residents, business owners, city officials, and others. We appreciate the opportunity provided to our students by the City of Lowell, and wish it every success as it explores the many ideas and recommendations included in this plan.

Sincerely,

Terry S. Szold, Adjunct Associate Professor

Eran Ben-Joseph, Associate Professor

PRESENTATION TO COMMUNITY | THURSDAY, OCTOBER 20, 2005

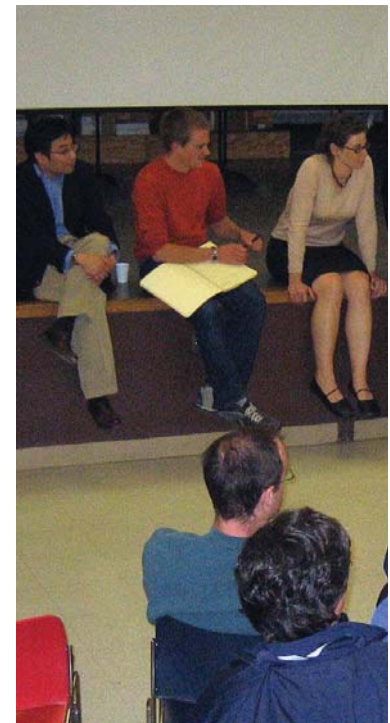



PRESENTATION TO COMMUNITY | TUESDAY, DECEMBER 06, 2005





ACKNOWLEDGEMENTS & PARTICIPANTS

CREDITS

While we thank the inputs and contributions of the individuals listed in the acknowledgements, the MIT students and instructors directly involved in the workshop assume full responsibility for the content of this report and any errors therein.

LOWELL

City of Lowell

Armand P. Mericer
Mayor

William F. Martin, Jr.
Vice Mayor

CITY COUNCIL MEMBERS

Kevin Broderick
Edward P. Caulfield
Eileen M. Donoghue
Rodney M. Elliot
Richard P. Howe
Rita M. Mercier
James L. Milinazzo

PLANNING BOARD

George Zaharoolis
Chairman

ZONING SUBCOMMITTEE

Bill Martin
Chairman

John Cox
City Manager

J. Matthew Coggins
Assistant City Manager/DPD Director

Adam Baacke
Deputy Director, DPD

Anne Barton
Deputy Director, DPD

George Proakis
Chief Planner

Brian Connors
Economic Development Director

James Errickson
Associate Planner

Christine Thomas
Environmental Officer/
Conservation Commission

Mario Madrid
Traffic Engineer

CENTRALVILLE

Maria Dickinson
Economic Development Officer
Office of Economic Development

Joe Boyle
Neighborhood Planner

Stephen Stowell
Historic Board Administrator

Jason Carter
Lowell DPD Intern

Joseph Guthrie
Building Commissioner

Andrew St. Onge
Special Event Coordinator

NATIONAL PARK SERVICE
Mehmed Ali
Coordinator, Patrick J. Mogan
Cultural Center

Philip Lupsiewicz
Public Information Officer

**CENTRALVILLE
NEIGHBORHOOD ACTION GROUP**

Conrad Gauthier
James Jozokos
Ann Marie Page

**CENTRALVILLE
NEIGHBORHOOD PARTNERSHIP**

Richard Lockhart

CENTRALVILLE RESIDENTS

Dick Barry
Mike Walsh

Reverend Albert L. Capone
St. Michael Parish

Sister Irene Martineau
Principal, St. Louis School

Lawrence Carradini
President, Lowell Celebrates Kerouac!

Edmund Mulcahy
Owner, Store 24

In addition we would like to thank all of the **Centralville businesses and local residents** who took the time to meet and listen to us.

INSTRUCTORS

PROFESSORS

Terry S. Szold
Adjunct Associate Professor of
Land Use Planning

Eran Ben-Joseph
Associate Professor of
Landscape Architecture and Planning

TEACHING ASSISTANT

Marlon Aranda

GROUP EDITORS

Anne Dodge
Stephanie Groll
Taylor Mammen
Anna Wells

STUDENTS



NEIGHBORHOOD NODES & FABRIC

Xixi Chen, MCP
Anne Dodge, MCP
Shilpa Mehta, MCP
Harris Morrison, MSRED
Brittanya A. Murillo, MCP

SIXTH AND WEST SIXTH STREET

Karl Baker, MCP/JD
Yew Chin Tan, MSRED
Thacher Tiffany, MCP
Kristy Wang, MCP/MSRED
Anna Wells, MCP

RIVERWAY

Tara Blakey, MST
Luis Canizo, MSRED
Ifeoma Ebo, MCP
Taylor Mammen, MCP
Hua Wang, MCP

BRIDGE STREET

Stephanie Groll, MCP
Dalia Leven, MCP/MST
Miguel Rodriguez, MCP
Carrie Vanderford, MCP
Albert S. Wei, MCP/SMArchS
Barrett E. Yates, MSRED



MASSACHUSETTS INSTITUTE OF TECHNOLOGY
DEPARTMENT OF URBAN STUDIES AND PLANNING

City Design and Development Group
77 Massachusetts Avenue, Room 10-485
Cambridge, Massachusetts 02141
<http://dusp.mit.edu>