

13.42 Design Principles for Ocean Vehicles

Prof. A.H. Techet
Spring 2005

1. Dynamical Systems

Dynamical systems are representations of physical objects or behaviors such that the output of the system depends on present and past values of the input to the system. For example:

$$y(t) = \int_{t-3}^t u^3(t_1) dt_1$$

$$y(t) = u(t) + \sum_{n=1}^N u(t - nd)$$

In order to model dynamical systems we need to build a set of tools and guidelines that can be used to analyze systems such as a ship in waves. This section will introduce tools for analyzing linear systems.

- System:** Recognize a set of physical objects (behaviors) of interest
- Modeling:** Representing the behavior of this system through a set of equations that approximate the original *physical* system.
- Inputs:** Identify external actions influencing the system behavior.
- Outputs:** Identify the outputs of interest.

1.1. Time Invariant System

Systems are time invariant if their behavior and characteristics do not vary over time. In other words, if the input to a system is shifted in time, the resulting output experiences an identical time shift. In order to determine whether the system is time invariant, we use the following procedure in three steps:

- Step 1:** Replace $u(t)$ by $u(t+\mathbf{t})$ (Change of variables)
- Step 2:** Replace $y(t)$ by $y(t+\mathbf{t})$ (Replace all occurrences of t with $t+\mathbf{t}$)
- Step 3:** Are the results from steps 1 and 2 equal?

To illustrate this procedure we can use a few simple examples of basic systems with input, $x(t)$, and output, $y(t)$.

Example 1: $y(t) = [u(t)]^{3/4}$ System is clearly time invariant: $y(t+\mathbf{t}) = [u(t+\mathbf{t})]^{3/4}$

Example 2: $y(t) = \int_0^t \sqrt{u(t_1)} dt_1$ Check time invariance:

Step (1): Plug in $t_1 + \mathbf{t}$ for t_1 on the RHS and perform a change of variables (let $\mathbf{z} = t_1 + \mathbf{t}$). Note that the limits of integration must also shift with this change of variables.

$$\int_0^t \sqrt{u(t_1 + \mathbf{t})} dt_1 = \int_{\mathbf{t}}^{t+\mathbf{t}} \sqrt{u(\mathbf{z})} d\mathbf{z}$$

Step (2): Plug in $t+\mathbf{t}$ for t on the LHS. Notice that the limits of integration do not change in the same fashion as in step 1. The original integral on the RHS is bounded from zero to t , and since we are simply replacing all occurrences of t with $t+\mathbf{t}$ we do not shift the limits of integration as we did in step 1.

$$y(t+\mathbf{t}) = \int_0^{t+\mathbf{t}} \sqrt{u(t_1)} dt_1$$

Step (3): Compare results from steps (1) and (2). They are **not** equal, therefore this system is not time invariant.

$$\int_{\mathbf{t}}^{t+\mathbf{t}} \sqrt{u(\mathbf{z})} d\mathbf{z} \neq \int_0^{t+\mathbf{t}} \sqrt{u(t_1)} dt_1$$

Example 3: $y(t) = \int_{t-5}^t u^4(t_1) dt_1$

Step (1): Plug in $t_1 + \mathbf{t}$ for t_1 on the RHS and perform a change of variables (let $\mathbf{z} = t_1 + \mathbf{t}$):

$$\int_{t-5}^t u^4(t_1 + \mathbf{t}) dt_1 = \int_{t-5+\mathbf{t}}^{t+\mathbf{t}} u^4(\mathbf{z}) d\mathbf{z}$$

Step (2): Plug in $t + \mathbf{t}$ for t on the LHS, and again, note the shift in integration limits:

$$y(t + \mathbf{t}) = \int_{t-5+\mathbf{t}}^{t+\mathbf{t}} u^4(t_1) dt_1$$

Step (3): Compare steps (1) and (2). They are equivalent, therefore system is time invariant!

$$\int_{t-5+\mathbf{t}}^{t+\mathbf{t}} u^4(\mathbf{z}) d\mathbf{z} = \int_{t-5+\mathbf{t}}^{t+\mathbf{t}} u^4(t_1) dt_1$$

1.2. Linear Dynamical System

A subset of dynamical systems is linear dynamical systems. A system is considered to be linear if it satisfies properties of linear superposition and scaling. Typically we can represent, mathematically, a system with some input, $x(t)$, and output, $y(t)$. Figure 1 illustrates typical notation for a linear system, L , where the function $x(t)$ is input into the system, shown as a box, and the system returns the output signal $y(t)$. The arrows indicate whether the function is being input or output from the system.

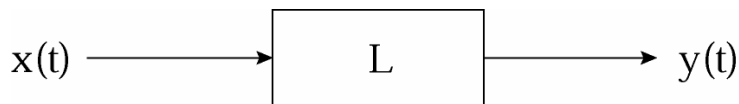

Figure 1. Block diagram of linear system with input $x(t)$ and output $y(t)$.

In general, given a *linear system* L , as shown in figure 1, and some input, $x_1(t)$, the system would result in an output, $y_1(t)$, conversely some other input, $x_2(t)$, into the same system would simply yield the output, $y_2(t)$, such that the inputs and outputs obey the following properties:

Linear Superposition:

$$x_1(t) + x_2(t) \longrightarrow y_1(t) + y_2(t)$$

Scaling:

$$ax_1(t) \longrightarrow ay_1(t)$$

Superposition and Scaling:

$$a_1x_1(t) + a_2x_2(t) \longrightarrow a_1y_1(t) + a_2y_2(t)$$

A system must satisfy both the superposition and the scaling criteria for it to be considered linear.

Example 1: $y(t) = C \frac{du}{dt}$. This system is linear.

Example 2: $y(t) = \int_0^t u(t_1) dt_1$. This system is linear. (But it is not time invariant!)

Example 3: $y(t) = au^3(t)$. This system is not linear. (But it *is* time invariant!)

1.3. Linear, Time-Invariant (LTI) Systems

Systems that satisfy both the linear and the time invariant criteria are considered Linear Time-invariant, or LTI, systems. The property of superposition makes LTI systems easier to analyze. By representing complex inputs as the superposition of basic signals, such as an impulse, we can then use superposition to determine the system output.

1.4. Unit Impulse

We can characterize a time-continuous LTI system by understanding its response to a unit impulse. A unit impulse, $u_o(t)$, otherwise known as the delta function (see fig 2), is an idealization of a pulse which is so short that its duration, dt is inconsequential for any real system.

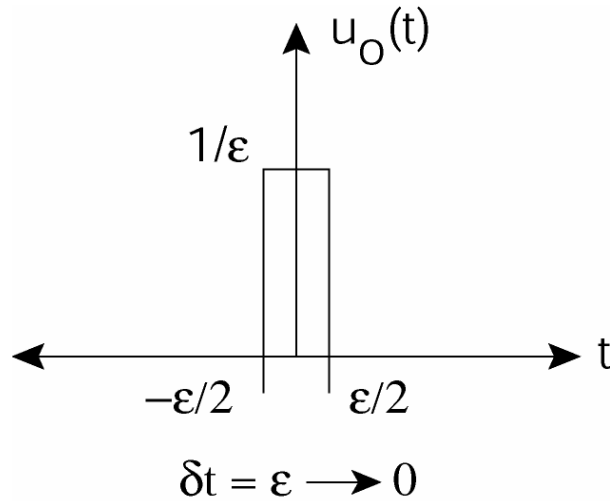

Figure 2. Delta (impulse) function with height $1/\epsilon$ between times $-\epsilon/2$ and $\epsilon/2$ as $\delta t = \epsilon$ goes to zero.

Any continuous single-valued function, $f(t)$, can be represented as a sum of scaled and time shifted unit impulses:

$$u_o(t) = \begin{cases} 1/\epsilon; & |t| \leq \epsilon/2 \\ 0; & |t| > \epsilon/2 \end{cases} \quad (1)$$

The integral of an impulse from minus infinity to infinity is 1 and $u_o(t)$ is an even function: $u_o(t) = u_o(-t)$. Impulses can be scaled, shifted and summed to represent a function $f(t)$, see figure 3.

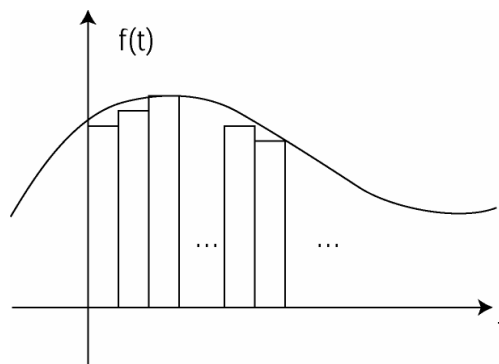

Figure 3. A function $f(t)$ represented as a sum of scaled and time-shifted impulses.

The impulse function has the following properties:

$$\int_{-\infty}^{+\infty} u_o(t) dt = 1 \quad (2)$$

$$f(t) = \int_{-\infty}^{+\infty} f(\mathbf{t}) u_o(t-\mathbf{t}) dt \quad (3)$$

$$\int_{-\infty}^{+\infty} f(t) u_o(t-a) dt = f(a) \quad (4)$$

Let's take a closer look at equation (4) from above. Here the value of the constant a is set to zero and we see that the integral simply equals that function $f(t)$ evaluated at $t=0$.

$$\begin{aligned} \int_{-\infty}^{+\infty} f(t) u_o(t) dt &= \lim_{\epsilon \rightarrow 0} \int_{-\epsilon/2}^{+\epsilon/2} f(t) u_o(t) dt \\ &= \lim_{\epsilon \rightarrow 0} f(0) \int_{-\epsilon/2}^{+\epsilon/2} u_o(t) dt \\ &= f(0) \end{aligned}$$

1.5. Impulse Response of an LTI system

We can obtain a complete characterization of a continuous-time LTI system in terms of its unit *impulse response*. The impulse response is simply the response of the system to a unit impulse input. Since it is possible to characterize a signal, or input, $x(t)$, as a series of scaled impulses, we can also represent the output as a series of scaled and shifted impulse responses, given that the system is LTI. But we'll get to that in a moment.

For now let's just look at a simple continuous time LTI system with a impulse input, $u_o(t)$, shown in figure 4. The output corresponding to the impulse input is the impulse response, $h(t)$. Understanding the impulse response will be pivotal in determining the behavior of the system to an arbitrary input.



Figure 4. The impulse response of a linear time-invariant (LTI) system.

1.6. Convolution

Given a continuous-time LTI system characterized by a unique impulse response, $h(t)$, the response of this system to some input, $x(t)$, at time $t = t$ is simply the input weighted by the time-shifted impulse response: $x(t)h(t - t)$.

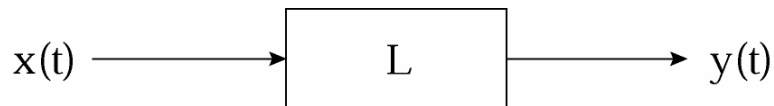

Figure 5. Linear system with input $x(t)$ and output $y(t)$.

Therefore, in order to determine the output of the system, $y(t)$, to an input, $x(t)$, we can integrate all possible outputs (responses), $x(t)h(t - t)$, in the time interval from minus infinity to positive infinity:

$$y(t) = \int_{-\infty}^{+\infty} x(t)h(t - t)dt \quad (5)$$

Thus for any continuous time LTI system, the output $y(t)$ is a weighted integral of the input, $x(t)$, where the weight on $x(t)$ is $h(t - t)$, the time shifted unit impulse response. The integral in equation 5 is the convolution integral, which, through a change of variables, can also be written as

$$y(t) = \int_{-\infty}^{+\infty} x(t - t)h(t)dt. \quad (6)$$

Symbolically, we typically represent the convolution integral as

$$y(t) = x(t) * h(t). \quad (7)$$

1.7. Causality

A causal system responds only *after* being excited (i.e if the input $x(t)$ is zero before t_0 therefore the output is also zero before t_0). In reality all physical systems are causal. Thus the response, $y(t)$, to the input is *zero* before time $t = 0$ and we can rewrite the convolution integral with integration limited to the interval $[0 < t < +\infty]$:

$$y(t) = \int_{-\infty}^{+\infty} x(\mathbf{t})h(t-\mathbf{t})d\mathbf{t} = \int_0^{+\infty} x(\mathbf{t})h(t-\mathbf{t})d\mathbf{t} \quad (8)$$

Since we are considering dynamical systems that depend only on past and present inputs, and that cannot “see” into the future, the response is also bounded by the current time, t :

$$y(t) = \int_0^t u(\mathbf{t})h(t-\mathbf{t})d\mathbf{t} \quad (9)$$

2. Finding the impulse response of a typical linear system

Take for example a linear mass-spring-dashpot system as shown in figure 6, which in our case could be a floating vessel in heave, where the damping forces is determined from viscous damping, the spring constant is the hydrostatic restoring force, the system mass is the ship mass plus the ship added mass, and the forcing term, $f(t)$, is the wave forces acting on the floating vessel.

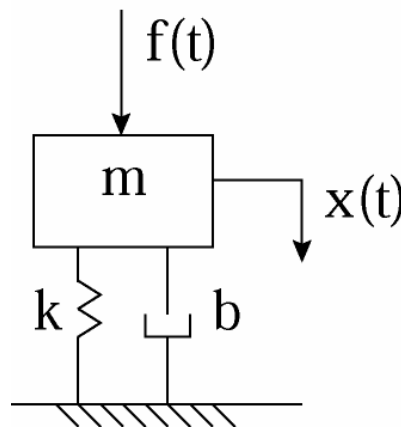

Figure 6. Mass-spring-dashpot system

This system has a lumped mass, m , that moves some distance, $x(t)$, as a function of time. The mass experiences a spring restoring force, $f_s = -kx(t)$, proportional to the spring constant times the distance the mass moves, and a damping term, $f_d = -b\dot{x}(t)$, proportional to the damping coefficient times velocity of the mass, and an external applied body force, $f(t)$. A simple free body diagram helps illustrate that the sum of the spring, damping, and applied forces must, by Newton's second law, equal the system mass times the acceleration of the object:

$$\sum F_{body} = -b\dot{x}(t) - kx(t) + f(t) = m\ddot{x}(t) \quad (10)$$

Reordering terms we arrive at the classic differential equation for a mass-spring-dashpot system.

$$m\ddot{x}(t) + b\dot{x}(t) + kx(t) = f(t) \quad (11)$$

In order to evaluate the system appropriately, we can use the following steps:

1. First, we need to identify the initial conditions. In this case, we assume our system starts at rest, such that the position and velocity of the mass are zero:

$$\begin{aligned} x(0) &= 0 \\ \dot{x}(0) &= 0 \end{aligned} \quad (12)$$

2. Next we need to apply an impulsive force, $f(t) = u_o(t)$, as the input to our system, at time $t = 0$, to characterize our system. Thus integrating the system equation over the duration of the impulse, $\mathbf{d}t = \mathbf{e}$, yields:

$$\int_{-\mathbf{e}/2}^{\mathbf{e}/2} \{m\ddot{x} + b\dot{x} + kx\} dt = \int_{-\mathbf{e}/2}^{\mathbf{e}/2} \{f(t)\} dt = 1 \quad (13)$$

Since $\mathbf{e}/2$ is an infinitesimally small time interval, before time zero we can write $t = -\mathbf{e}/2$ as $t = 0^-$. Following the same logic we can also write $t = +\mathbf{e}/2$ as $t = 0^+$. Considering the integral in equation 13 and the initial conditions on

position and velocity, we arrive at

$$m\{\dot{x}(0^+) - \dot{x}(0^-)\} = 1 \quad (14)$$

The term $\dot{x}(0^-)$ is zero since there is no motion before time zero and we are left with the velocity just after the force is applied:

$$\dot{x}(0^+) = \frac{1}{m} \quad (15)$$

3. For time, $t > 0$, the initial value problem becomes:

$$m\ddot{x} + b\dot{x} + kx = 0 \quad (16)$$

$$x(0) = 0 \quad (17)$$

$$\dot{x}(0^+) = \frac{1}{m} \quad (18)$$

The solution to this initial value problem takes the form

$$x(t) = C_1 e^{s_1 t} + C_2 e^{s_2 t} \quad (19)$$

We can find the constants using the original system equation such that

$$ms^2 + bs + k = 0$$

$$s_{1,2} = -\frac{b}{2m} \pm \frac{\sqrt{b^2 - 4km}}{2m}$$

$$\text{let } \mathbf{d} = \frac{b}{2m} \quad \text{and} \quad \mathbf{w} = \sqrt{\frac{k}{m} - \frac{b^2}{4m}}$$

$$s_{1,2} = -\mathbf{d} \pm i\mathbf{w}.$$

Let us assume $b^2 < 4km$ ($\mathbf{z} = \frac{b}{2\sqrt{km}} < 1$), then

$$x(0) = C_1 + C_2 = 0 \rightarrow C_1 = -C_2$$

$$\dot{x}(0) = C_1 s_1 + C_2 s_2 = C_1 (s_1 - s_2) = \frac{1}{m}$$

$$s_1 - s_2 = \mathbf{d} + i\mathbf{w}_d - (\mathbf{d} - i\mathbf{w}_d)$$

$$\text{therefore } C_{1,2} = \pm \frac{1}{2im\mathbf{w}_d}$$

Thus we can formulate the system response due to the impulsive force input as

$$x(t) = \frac{1}{2i m \omega_d} \left\{ e^{-dt} \left(e^{i\omega_d t} - e^{-i\omega_d t} \right) \right\}$$

Since

$$\sin(\omega_d t) = \frac{e^{i\omega_d t} - e^{-i\omega_d t}}{2i},$$

the impulse response can be written as

$$h(t) = \begin{cases} \frac{1}{m\omega_d} e^{-dt} \sin \omega_d t; & t \geq 0 \\ 0; & t < 0 \end{cases}$$

3. Useful References

There are several good texts on signals and systems that give a thorough discussion of Linear Time Invariant systems and their properties. A few suggestions are listed below.

- <http://www.engin.brown.edu/courses/en4> Course notes on Dynamics and Vibrations.
- A.V. Oppenheim, A. S. Willsky, S.H. Nawab (1997) *Signals and Systems, 2nd ed.* Prentice Hall Signal Processing Series, New Jersey. (6.003 Course text book)
- Triantafyllou and Chryssostomidis, (1980) "Environment Description, Force Prediction and Statistics for Design Applications in Ocean Engineering"