

## Acceleration measurements with piezo-electric accelerometers

The idealized accelerometer construction is a piezo-electric crystal which produces charge when squeezed. The squeeze force is produced by the inertia of a mass  $M$  as it is accelerated by the motion  $\ddot{y}(t)$  which is to be measured. Something like the picture below.

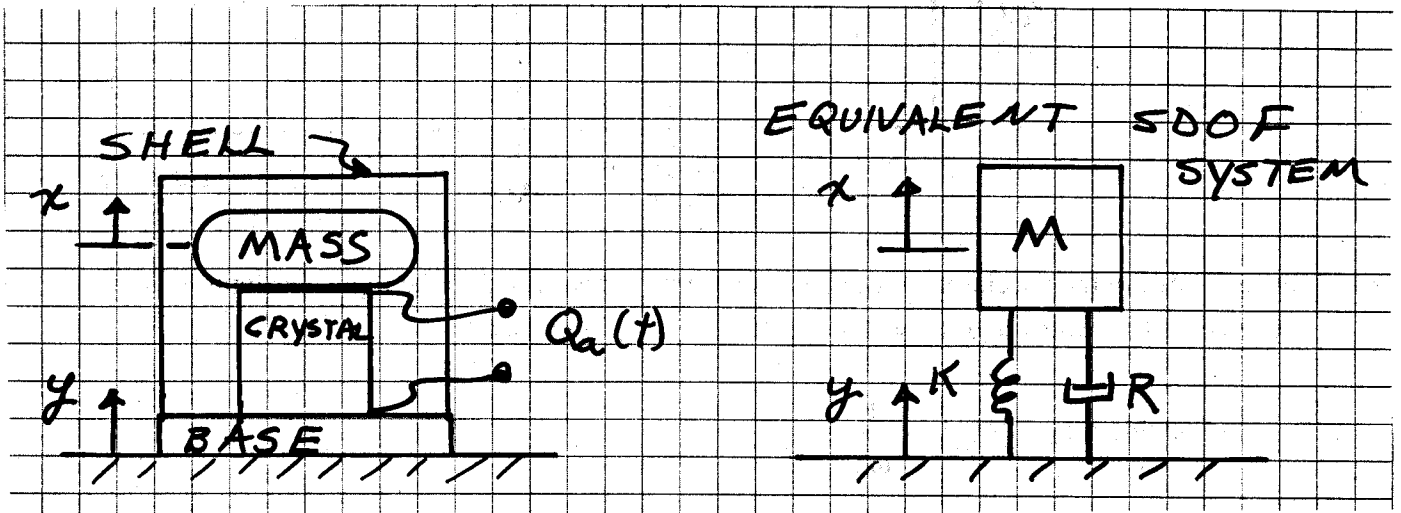

The squeeze displacement on the crystal is  $z = x - y$ . The charge produced  $Q_a(t)$  is proportional to  $z(t)$

$$Q_a(t) = b \cdot z(t)$$

The charge per unit squeeze,  $b$ , is a constant, a property of the particular crystal.

$$H_{Q/z} = b$$

The squeeze  $z(t) = x - y$  can be deduced from the equation of motion of the equivalent system.

$$M\ddot{z} + R\dot{z} + Kz = -M\ddot{y}$$

Let  $y(t) = y_0 e^{i\omega t}$  and  $z(t) = z_0 e^{i\omega t}$ , plug in and solve for the steady state transfer function  $H_{z/\ddot{y}}$ .

Note  $\ddot{y} = -\omega^2 y_0 e^{i\omega t}$

$$H_{z/\ddot{y}} = \frac{-1/\omega_0^2}{\left[ \left(1 - \frac{\omega^2}{\omega_0^2}\right) + 2i \frac{\zeta \omega}{\omega_0} \right]}$$

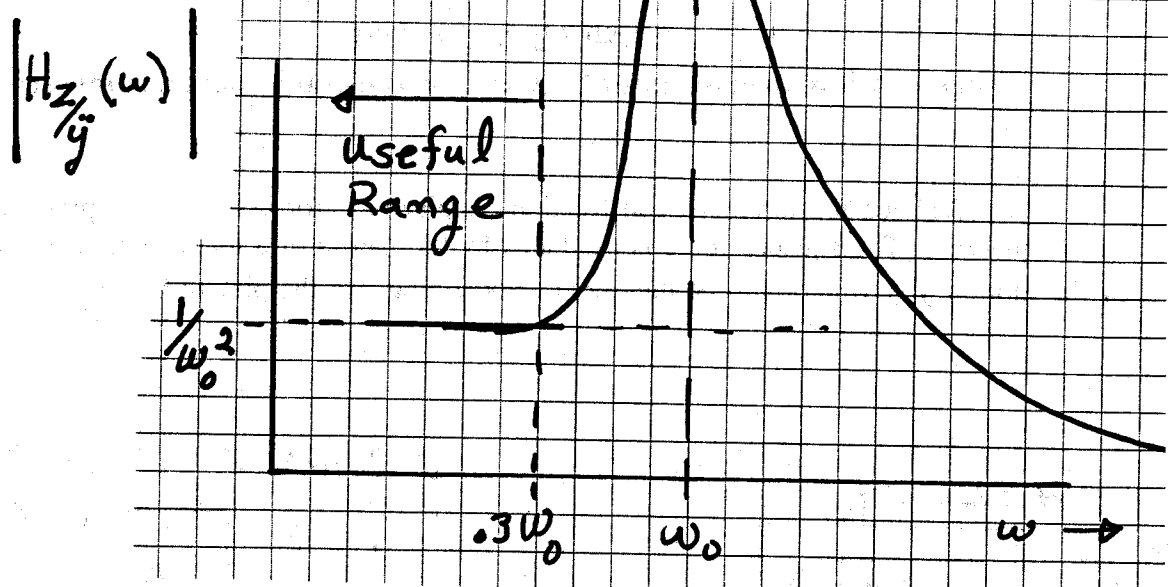

Since we desire the accelerometer to have an output proportional to the input acceleration  $\ddot{y}$ , then we restrict its useful range to  $\omega \leq 0.3\omega_0$ , where  $|H_{zy}|$  is constant

$$\text{For this range } |H_{zy}| = \frac{1}{\omega_0^2}$$

This combined with the charge produced per unit squeeze yields

$$S_{Q_{zy}} = |H_{Q_{yz}}||H_{zy}| = \frac{b}{\omega_0^2}$$

This would typically have units of pico coulombs per  $\text{m/s}^2$  ( $\text{pc/ms}^2$ )

If we multiple by  $9.8 \text{ ms}^{-2}/\text{g}$

$$S_{Q_{zg}} = S_{Q_{zy}} \times 9.8 \frac{\text{ms}^{-2}}{\text{g}} = \frac{9.8b}{\omega_0^2} \text{ (pico coulombs per g)}$$

The charge sensitivity,  $S_{Q_{zg}}$ , is a property of each accelerometer and is specified on its data sheet.

The idealized circuit equivalent of a piezo electric accelerometer is a charge source and a capacitor  $C_a$  representing the crystal.

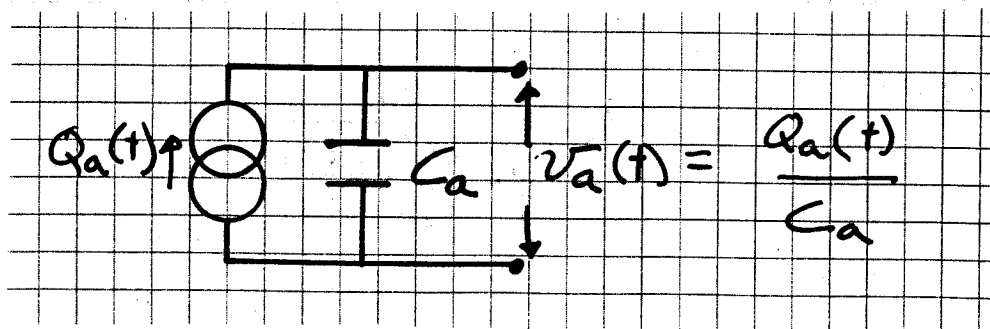

The voltage sensitivity  $S_{v/g}$  is therefore

$$S_{v/g} = S_{Q/g} \frac{1}{C_a} \text{ (typical units mv/g)}$$

$C_a$  is the capacitance of the accelerometer and is also given on the data sheet.

The properties which define a piezo electric accelerometer are  $S_{v/g}$  or  $S_{Q/g}$ ,  $C_a$ ,  $f_o$ ,  $R_a$ . We have discussed thus far all but  $R_a$ . Typical values for a rather large General Radio accelerometer are

$$S_{v/g} = 55 \frac{mV}{g}, \quad C_a = 10^4 \text{ pfarad} = 10^{-8} \text{ farad}$$

$$f_o = \frac{\omega_o}{2\pi} = 3000 \text{ Hz}, \quad R_a = 10^7 \text{ ohms.}$$

The upper limit frequency of this accelerometer is  $f_{upper} \approx \frac{1}{3} f_o$ , therefore  $f_{upper} = 1 \text{ KHZ}$

What is the practical lower limit of the useful range? How does external capacitance and measurement resistance affect the measured output from the accelerometer. A more realistic circuit diagram follows.

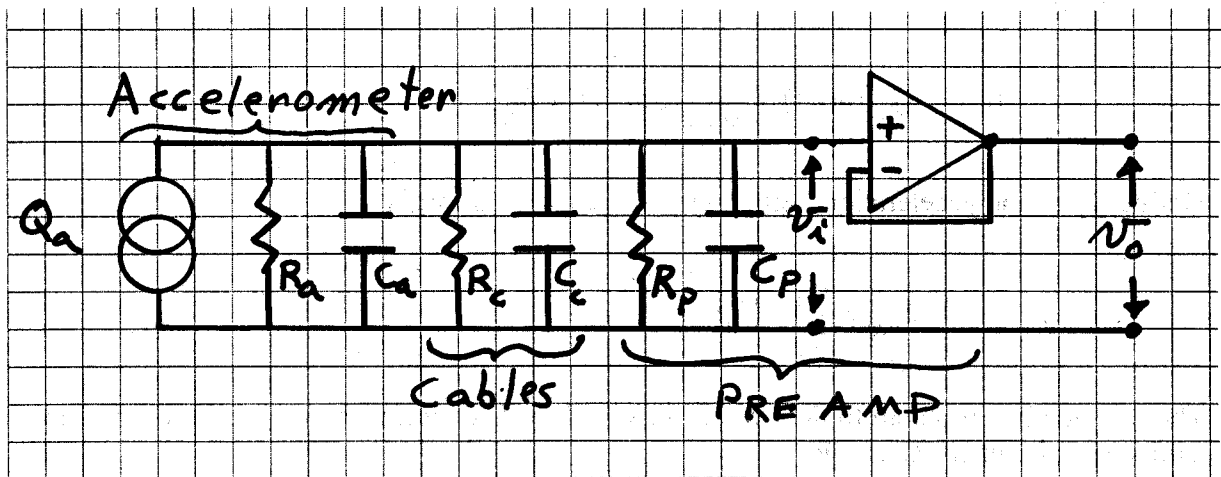

The equivalent resistance  $R_t$  and capacitance  $C_t$  are given by

$$\frac{1}{R_t} = \frac{1}{R_a} + \frac{1}{R_c} + \frac{1}{R_p}$$

$$C_t = C_a + C_c + C_p$$

where the subscripts a, c and p refer to the accelerometer, the cables, and the pre-amp respectively. The equivalent circuit would look like:

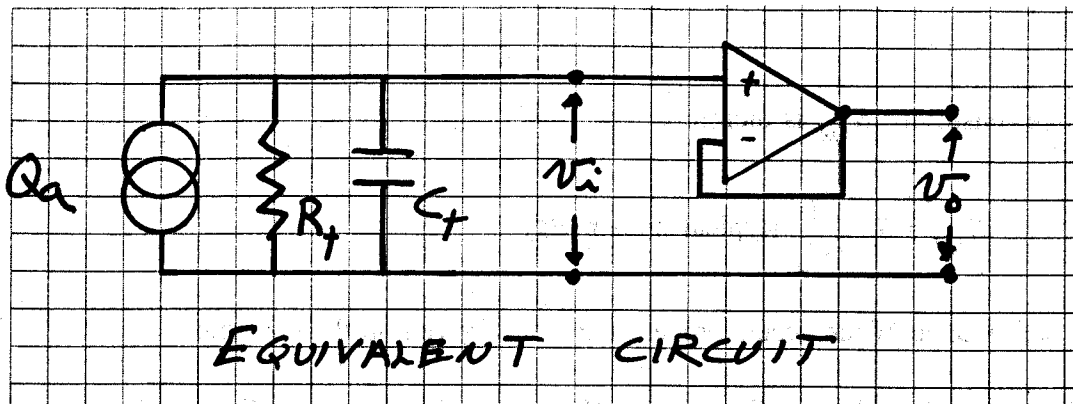

The open circuit (nothing attached) voltage sensitivity  $S_{V_{alg}}$  is effectively reduced by the additional capacitance. The effective voltage sensitivity

$$S_{V_{alg}} = S_{V_{alg}} \cdot \frac{C_a}{C_t} = S_{Q_{alg}} / C_t$$

The voltage sensitivity is reduced by the ratio  $C_a / C_t$ .

If  $\ddot{y}(t) = \ddot{y}_0 e^{i\omega t}$  and  $\omega$  is within the useful range, then the magnitude of the output of the accelerometer is

$$|v_o| = |\ddot{y}_0| (m/s^2) \times \frac{1}{9.81} (g/m-s^2) \times S_{V_{alg}}$$

Define  $\ddot{y}_g$  as the acceleration being measured expressed in g's.

$$|v_o| = S_{V_{alg}} \cdot \frac{C_a}{C_t} \cdot |\ddot{y}_g|$$

There is one last problem to deal with. At very low frequencies the charge leaks off due to the equivalent circuit resistance  $R_t$ .

If an initial charge  $Q_0$  were put on the equivalent circuit, there would be an initial voltage observed across the input to the ideal amplifier of

$$v_i(t=0) = \frac{Q_0}{C_t}$$

With time the voltage would drop in an exponential decay.

$$v_i(t) = v_i(0) [e^{-t/R_t C_t}]$$

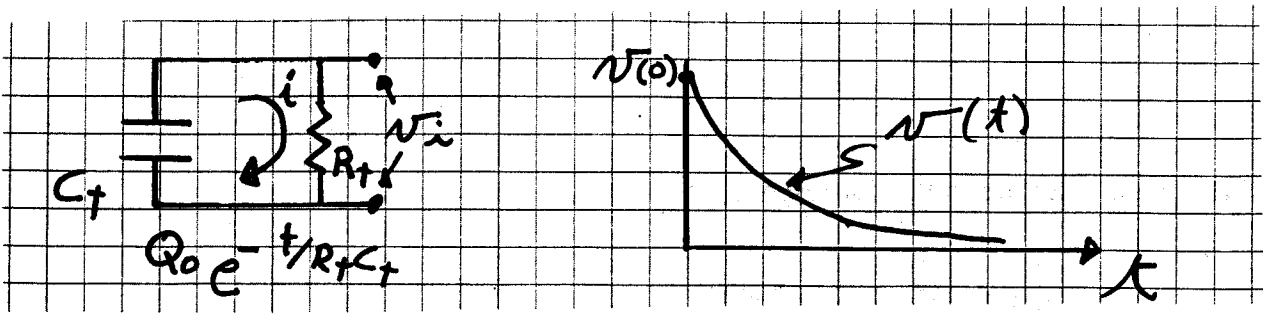

The time constant  $R_T C_T$  determines the rate of voltage decrease and the frequency response of the circuit to steady state vibration input. This circuit high pass filters the ideal voltage  $v(t)$  to yield the voltage output  $v_i(t)$ . The cutoff frequency of the filter is given by

$$f_c = \frac{1}{2\pi R_T C_T}$$

and the magnitude of the transfer function of the filter is

$$|H_{v/v_a}(\omega)| = \left| \frac{v_i}{v_a} \right| = \frac{1}{\left[ 1 + \left( \frac{1}{\omega R_T C_T} \right)^2 \right]^{1/2}}$$

$$= \frac{1}{\left[ 1 + \left( \frac{\omega_c}{\omega} \right)^2 \right]^{1/2}} = \frac{1}{\left[ 1 + \left( \frac{f_c}{f} \right)^2 \right]^{1/2}}$$

If we have a steady state acceleration  $\ddot{y}_g e^{i\omega t}$  (expressed in g's), then the voltage that would be measured at the input to the pre amp of the oscilloscope or A/D converter is given by

$$v_i(t) = |\ddot{y}_g| S_{v_d/g} \cdot \frac{C_a}{C_t} \cdot |H_{v/v_a}(\omega)| e^{i(\omega t - \phi)}$$

If one stays above the cutoff frequency of the filter then

$$|H_{v/v_a}| \approx 1.$$

If  $\omega < \omega_c = \frac{1}{R_T C_T}$  then the output voltage is reduced.

$|H_{v/v_a}|$  looks like

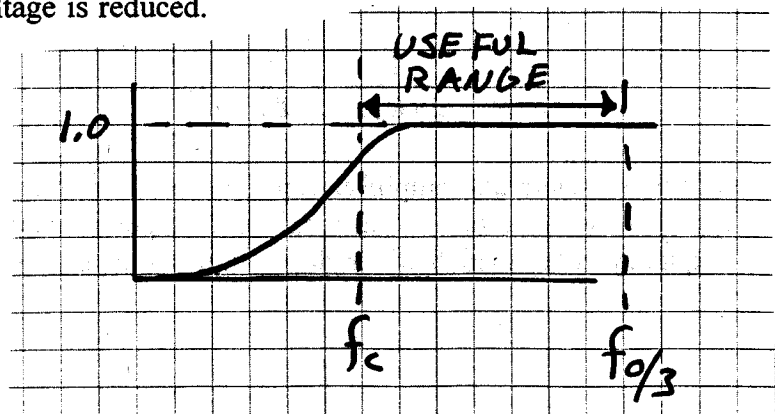

Let's assume we are in the flat response range, i.e.,

$$f_c \leq f \leq \frac{f_o}{3}, \quad \ddot{y}_g(t) = \ddot{y}_g e^{i\omega t}$$

then

$$v_o(t) = |\ddot{y}_g| S_{v_d/g} \cdot \frac{C_a}{C_t} e^{i(\omega t - \phi)}$$

What we measure is  $v_o(t)$ . What we want to know is

$$|\ddot{y}_g| e^{i(\omega t - \phi)}, \text{ so solving for}$$

$$|\ddot{y}_g| e^{i(\omega t - \phi)} = \frac{v_o(t)}{S_{v_d/g}} \frac{C_t}{C_a}$$

If  $C_a$  is reasonably large and you have a good quality scope and short cables, then  $C/C_a \approx 1.0$  is often true.

The approximate measured amplitude of the acceleration  $\ddot{y}$  (in g's) is

$$|\ddot{y}_g| \approx \frac{|v_o|}{S_{v_d/g}}$$

The absolute lowest cutoff frequency you can achieve is

$$f_{c_{best}} = \frac{1}{2\pi R_a C_a}$$

for the Gen Rad accelerometer

$$R_a = 10^7 \text{ ohms} \quad C_a = 10^{-8} \text{ farads}$$

$$f_{c_{best}} = \frac{1}{2\pi R_a C_a} = \frac{10}{2\pi} = 1.6 \text{ Hz}$$

Additional cable and amplifier capacitance will reduce the measured voltage and therefore the apparent acceleration. Additional finite input resistance of the scope will increase the low frequency cutoff which will reduce output voltage at low frequencies.

The Phase  $\phi$  between  $\ddot{y}$  and  $v_o(t)$  must usually be measured to accurately calibrate the system.

To summarize the typical steady state response or output transfer function for a piezo-electric accelerometer looks like the following

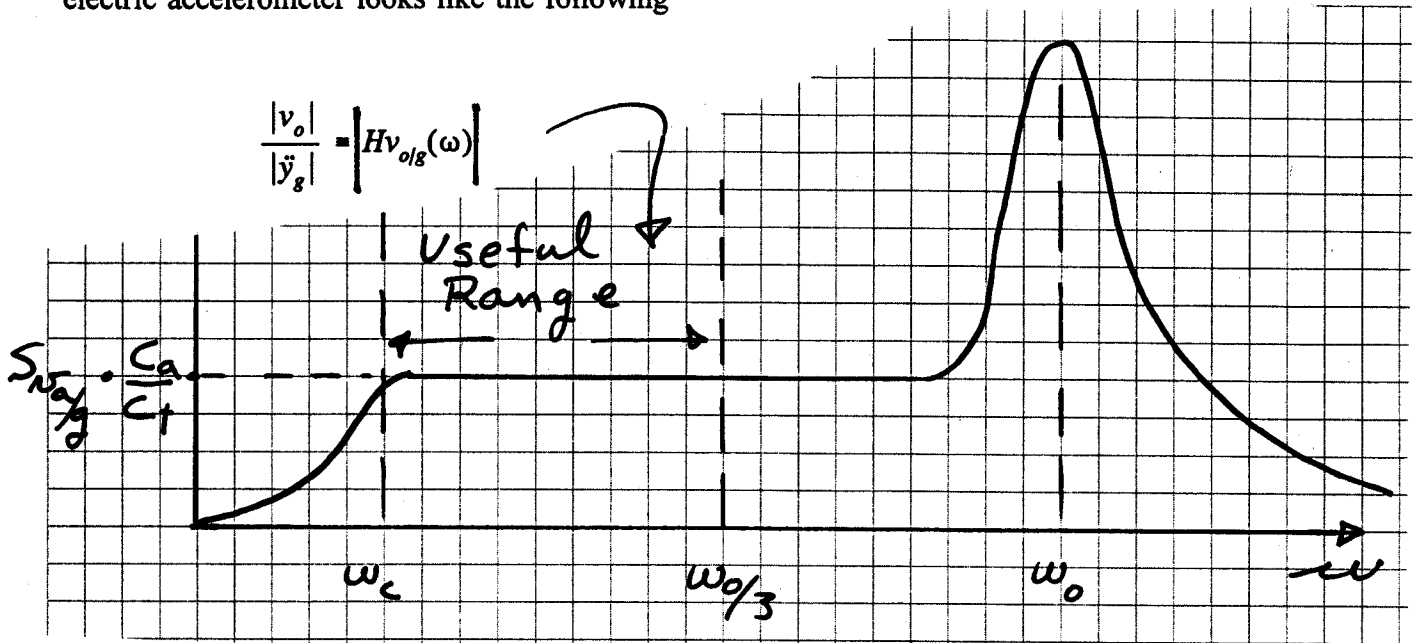

$$f_c = \frac{\omega_c}{2\pi} = \frac{1}{2\pi R_T C_T}$$

Outside of the range  $f_c \leq f \leq \frac{f_o}{3}$  the response will not be proportional to the input acceleration.

Some piezo-electric accelerometers such as ones known as ICP accelerometers come with the pre-amps built in, which eliminates the need to determine  $C_T$  and  $R_T$  because the sensitivity you are given is  $S_{v/g}$ . All ICP accelerometers have a low frequency cutoff just as in the figure. The output is only calibrated above the cutoff. All ICP accelerometers require external power. The company PMB supplies battery operated supplies which you will see in laboratory exercises. Some spectrum analyzers actually provide an option for ICP coupling. One chooses AC, DC or ICP coupling. An ICP accelerometer only has two wires. The pre-amp positive power is actually put on the output signal conductor, and then removed by a high pass filter in the spectrum analyzer or in the power supply.