

Massachusetts Institute of Technology
Department of Aeronautics and
Astronautics
Cambridge, MA 02139

16.01/16.02 Unified Engineering I, II
Fall 2003

Problem Set 10

Name: _____

Due Date: 11/12/03

	Time Spent (min)
F6	
F7	
F8	
M8	
M9	
M10	
Study Time	

Announcements:

F6. Determine the streamline shapes of the following 2-D velocity field.

$$u = \frac{-y}{x^2 + y^2} \qquad v = \frac{x}{x^2 + y^2}$$

Assuming the density is constant, does this flow obey the mass conservation law?

F7. A pipe of cross-sectional area A suddenly increases to an area of $10A$. The air velocity in the pipe is V , and the pressure at station 1 is p_1 . After undergoing mixing in the larger pipe, the velocity becomes uniform again at station 2, where the velocity is V_2 , and the pressure is p_2 . Assume the density ρ is constant everywhere (low speed flow). Be sure to clearly draw the control volume you will be using.



- Determine the velocity V_2 .
- Determine the pressure difference $p_2 - p_1$.

F8. A cascade of vanes turns the airflow around each corner of the Wright Brothers Wind Tunnel. Assume the flow parameters are:

- | | |
|------------------------|-----------------------------|
| constant air density: | $\rho = 1.2 \text{ kg/m}^3$ |
| upstream air velocity: | $V = 30 \text{ m/s}$ |
| vane spacing: | $h = 0.4 \text{ m}$ |
| vane span: | $b = 2.5 \text{ m}$ |
| upstream flow angle: | 45° |
| downstream flow angle: | -45° |

Determine the force on each vane. Again, clearly draw a suitable control volume for your analysis.

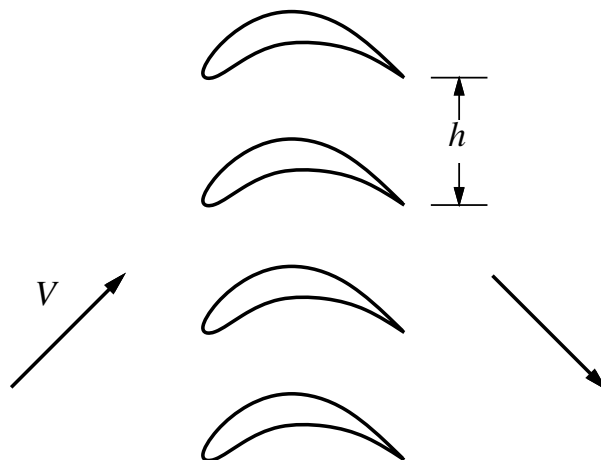

Problem M8 (Materials and Structures)

For the truss shown below (and analyzed in M7) calculate the deflection of point D under the loading shown. The bars have length L or $\sqrt{2}L$ and all angles are either 90° or 45° . The bars have cross-sectional area A and they are made of a material with Young's modulus E . **Hint**, draw a displacement diagram starting at points E and D – what can you say about the displacement of D relative to E given that this is a symmetric structure?.

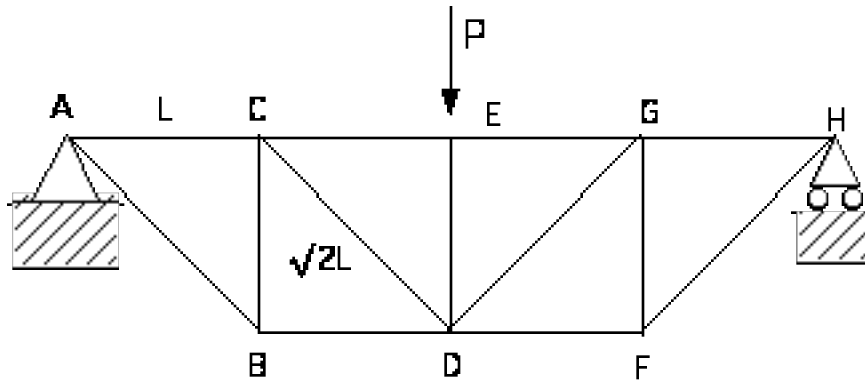

Since this is the truss that you are experimenting with in the truss lab, you can also compare the results of the experiments to the analysis. By assuming values for L , A and E (70 GPa for aluminum, 210 GPa for steel) estimate the relationship between applied load and the deflection of point D for the experimental truss and compare with your data. If the two results are not similar, suggest potential reasons for the discrepancy.

Problem M9 (Materials and Structures)

In the truss shown below determine the deflection of point D under the 10kN load shown (horizontal and vertical components). The force-displacement relationship for the bars (in the absence of any temperature change) is given by $\Delta = \frac{FL}{AE}$ where Δ is the bar extension, L, the length of the bar, A, the bar cross-section and E the Young's Modulus. For the bars in this problem $A = 500 \times 10^{-6} \text{ m}^2$, $E = 70 \times 10^9 \text{ N/m}^2$. Assume that the deformations of the bars are small compared to their length.

Angles BAC and ACD are both right angles, BC and AD are parallel to each other.

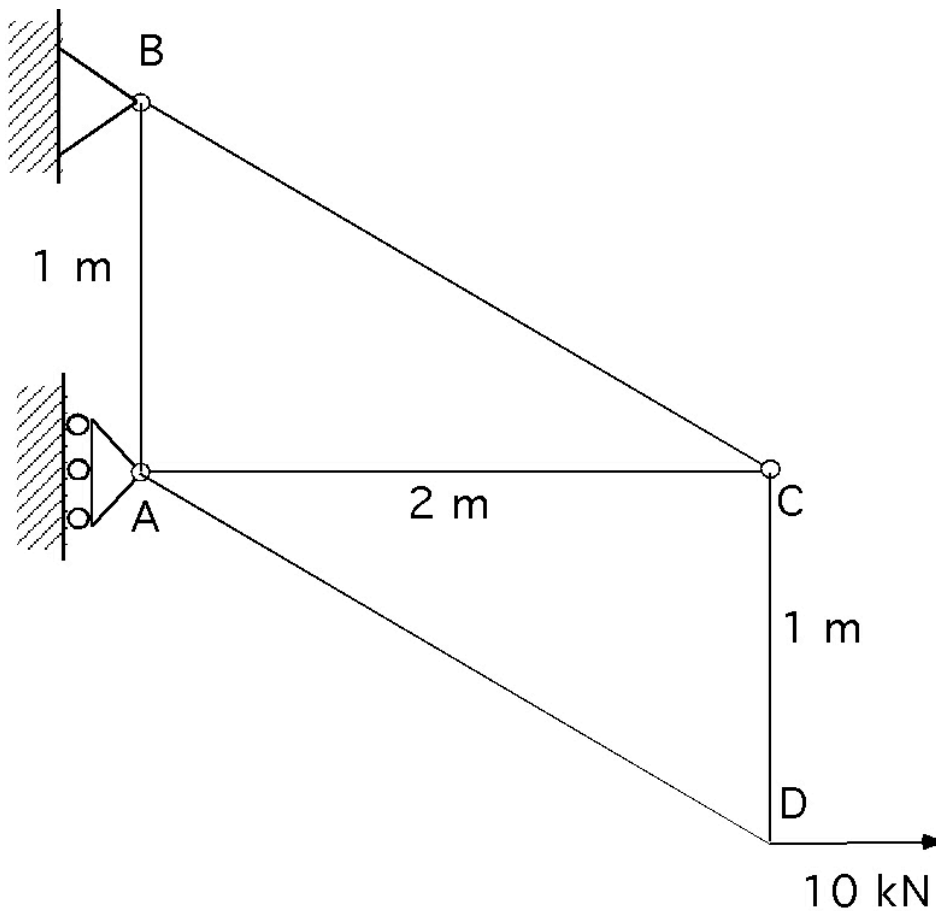

Problem M10(Materials and Structures)

An additional constraint is now applied to the truss in M9, a roller is placed at D.

- a) What is the deflection of D now?
- b) What are the reactions at A, B and D?

