

Massachusetts Institute of Technology
Department of Aeronautics and
Astronautics
Cambridge, MA 02139

16.03/16.04 Unified Engineering III, IV
Spring 2004

Problem Set 3

Name: _____

Due Date: 2/24/04

	Time Spent (min)
F7	
F8	
F9/F10	
M7/M8	
M9	
Study Time	

Announcements:

F7. The profile drag of a particular wing is assumed to be some given constant over the expected range of operating C_L 's.

$$c_d \simeq \text{constant}$$

For an elliptically-loaded wing of some aspect ratio $AR \dots$

a) Determine the operating C_L at which the lift/drag ratio C_L/C_D is maximized. This is the desirable operating point for maximum range. Determine how the C_D at this operating point compares to c_d .

b) Determine the operating C_L at which the “power coefficient” $C_L^{3/2}/C_D$ is maximized. This is the desirable operating point for maximum endurance. Determine how the C_D at this operating point compares to c_d .

F8. A wing is to have an elliptic circulation distribution.

$$\Gamma(y) = \Gamma_0 \sqrt{1 - \left(\frac{2y}{b}\right)^2}$$

The planform is to be a straight taper, with root and tip chords defined in terms of the average chord c_{avg} and the *taper ratio* $r = c_t/c_r$.

$$c_r = c_{\text{avg}} \frac{2}{1+r} \qquad c_t = c_{\text{avg}} \frac{2r}{1+r}$$

a) Define the chord distribution $c(y)$ in terms of c_{avg} and r . Assuming $c_{\text{avg}}/b = 0.125$, draw the planforms for $r = 0.75, 0.5, 0.25$.

b) Determine the spanwise $c_\ell(y)$ distribution, and plot for $r = 0.75, 0.5, 0.25$.

Note: Only the shape of the $c_\ell(y)$ curve is of interest. All scaling constants like Γ_0 , c_{avg} , etc. can be set to unity for plotting purposes.

c) Local stall is obviously undesirable. If the airfoil is the same across the span, which taper ratio appears to be most attractive for the purpose of giving the largest stall margin everywhere on the wing?

F9+F10. The circulation distribution on a wing is

$$\Gamma(\theta) = 2bV_\infty (A_1 \sin \theta + A_2 \sin 2\theta)$$

where $A_1 = 0.05$, and $A_2 = 0.01$.

a) Determine and plot $\alpha_i(y)$.

b) Determine the rolling moment on the entire wing.

$$M_{\text{roll}} = \int_{-b/2}^{b/2} \rho V_\infty \Gamma y dy$$

Problem M7 and M8 (this is a two hour question)

A simply supported aluminum alloy beam is 3 m long and has a cross-section which is an “I” cross-section 200 mm high and 100 mm wide. A uniform distributed load of 6 kN/m acts on the left hand two thirds of the beam. The Young’s modulus of the aluminum alloy is 70 GPa. The yield stress is 300 MPa.

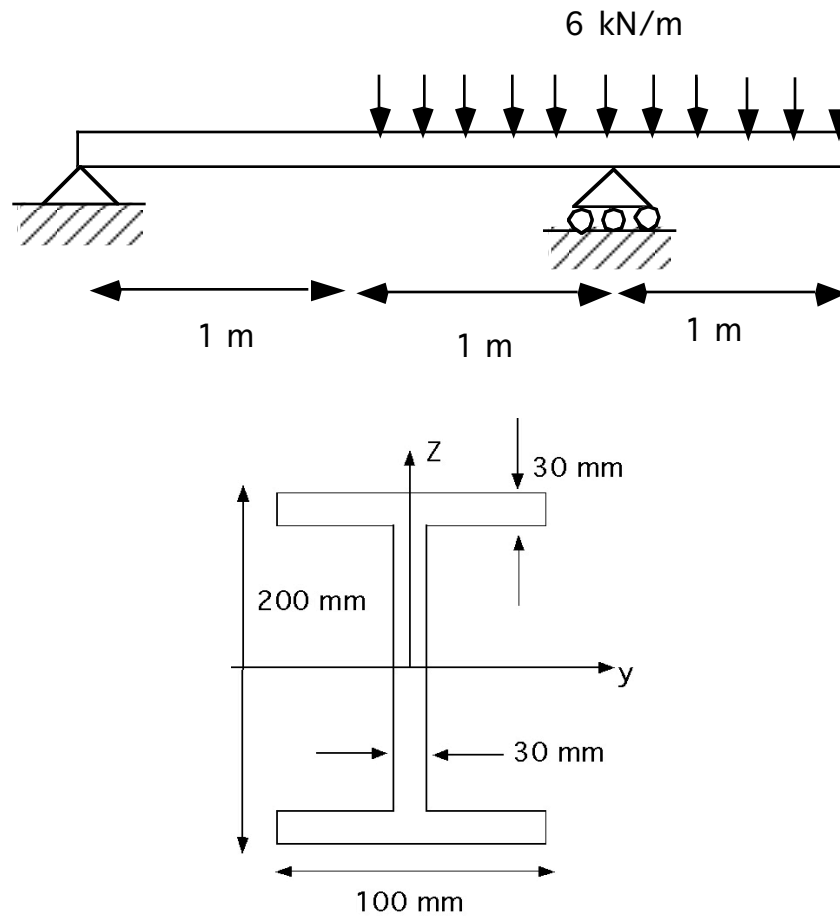



- a) Determine the loading, shear force and bending moment as functions of the distance x measured from the left end of the beam. Draw the appropriate diagrams.
- b) Determine the maximum deflection(s) of the beam and its (their) location(s).
- c) Determine the magnitudes and locations of the maximum axial stress, σ_{xx} and the maximum shear stress, τ_{xz} . Will the aluminum alloy yield?

Problem M9

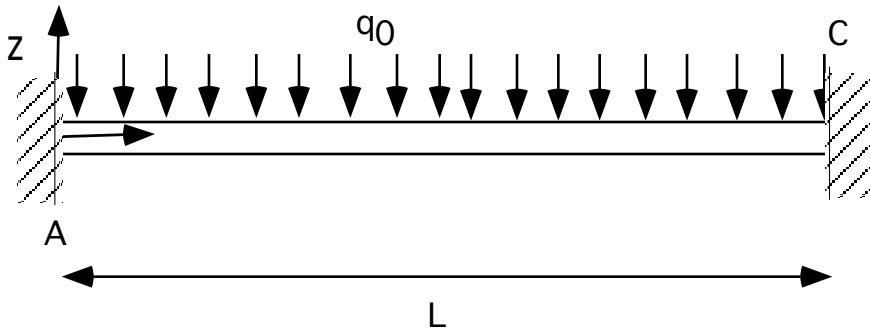
A beam of length L and flexural rigidity EI is clamped at each end. The beam has a continuous load of magnitude q_0 applied along the beam. Using the “standard solutions” below, or by other means, solve for the reactions at A and C.

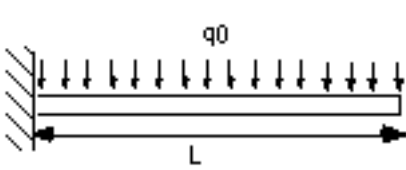
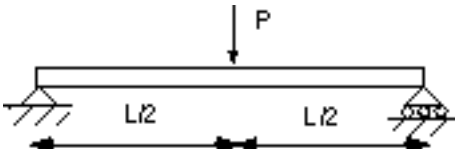
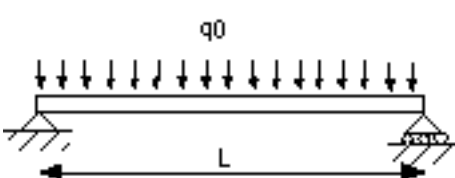

Standard solutions for deflections of beams under commonly encountered loading

Configuration	End slope $dw/dx (x=L)$	End deflection, $w(L)$	Central deflection, $w(L/2)$
	$\frac{ML}{EI}$	$\frac{ML^2}{2EI}$	
	$\frac{PL^2}{2EI}$	$\frac{PL^3}{3EI}$	
	$\frac{q_0L^3}{6EI}$	$\frac{q_0L^4}{8EI}$	
	$\frac{PL^2}{16EI}$		$\frac{PL^3}{48EI}$
	$\frac{q_0L^3}{24EI}$		$\frac{q_0L^4}{384EI}$