

1000 SERIES DC SERVOMOTORS

Brush, Rotary Servomotors

- Dynamically balanced, skewed rotor for exceptionally smooth velocity
- Standard NEMA 23, 34, 42, and 56 frame sizes
- Standard stainless-steel shaft resists corrosion
- Double shielded bearing for long motor life
- Options include tachometer, encoders, metric flange, and integral cable



The 1000 series motors are Aerotech's high-performance brush-type rotary DC servomotors. These motors are designed for a variety of general and high-performance motion control applications. Custom mechanical or electrical configurations are also available with minimal lead time.

Skewed Rotor is Better

The 1000 series DC motors feature a dynamically-balanced skewed rotor

and tachometer assembly for less cogging and smoother velocity control. The skewed laminations help reduce the effects of torque ripple that can cause velocity disturbance. The result is a much smoother velocity profile for such applications as machine tool, medical, semiconductor, and scanning.

Standard NEMA Frames

The 1000 series motors come in standard NEMA frame sizes including 23, 34, 42, and 56. The standardized flange and shaft dimensions make it easy to mount to existing NEMA-based machines.

from 0.12 N-m (17 oz-in) to 6.8 N-m (960 oz-in). Peak output torque ranges from 0.92 N-m (130 oz-in) to 31.7 N-m (4500 oz-in).

Customized for any Application

Standard motor models are available with and without a DC tachometer in different voltage gradients. Options include alternate windings, metric shafts and flanges, encoders with line driver or amplified sine-wave output, rear housings with integral cables, or MS-style heavy-duty connectors. 

Each motor is constructed from high-grade materials including a stainless-steel shaft, double-shielded bearings, and precision machined housing. Full burn-in of each motor ensures long-term reliable operation.

Wide Torque Range

The 1000 series DC motors cover a wide range of torque to meet virtually all high-end DC motor applications. Continuous output torque ranges

AEROTECH ADVANTAGES



Highly skewed armature and tachometer provide superior velocity stability and control.

1000 Series Rotary Motor Specifications

MOTOR MODEL	UNITS	1017	1035	1050	1075	1135	1210	1410	1580	1960
PERFORMANCE SPECIFICATIONS										
Stall Torque, Continuous	N-m oz-in	0.12 17	0.25 35	0.35 50	0.53 75	0.95 135	1.48 210	2.89 410	4.1 580	6.8 960
Peak Torque	N-m oz-in	0.92 130	1.84 260	2.52 355	2.87 406	5.22 736	7.1 1000	14.1 2000	16.9 2400	31.7 4500
Maximum Speed	rpm	6,500	6,000	6,000	5,000	5,000	3,000	2,750	2,750	2,750
Rated Power	W hp	60 0.1	129 0.2	146 0.2	140 0.2	200 0.3	220 0.3	380 0.5	650 0.9	1160 1.6
ELECTRICAL SPECIFICATIONS										
Winding Designation		-01	-01	-01	-01	-01	-01	-01	-01	-01
Continuous Stall Current	Amps	4.1	4.1	5.4	5.4	5.5	6.0	9.2	12.9	12.0
Torque Constant	N-m/Amp oz-in/Amp	0.03 4.1	0.06 8.5	0.07 9.3	0.10 14.0	0.17 24.5	0.25 35.0	0.31 44.5	0.31 45	0.56 80
Terminal Resistance	ohms	0.47	0.9	0.7	1.0	1.4	1.8	0.7	0.6	0.5
BEMF Constant	V _{pk} /krpm	3.04	6.3	6.9	10.4	18.2	25.9	32.8	3.04	6.3
Armature Inductance	mH	0.7	2.0	2.5	2.7	3.1	4.9	6.3	1.3	4.5
Armature Moment of Inertia	kg-m ² oz-in-s ²	2.8x10 ⁻⁵ 0.004	3.8x10 ⁻⁵ 0.005	5.7x10 ⁻⁵ 0.008	1.6x10 ⁻⁴ 0.023	3.5x10 ⁻⁴ 0.052	9.2x10 ⁻⁴ 0.13	1.3x10 ⁻³ 0.18	1.8x10 ⁻³ 0.26	2.6x10 ⁻³ 0.37
Recommended Bus Voltage	VDC	40	40	40	80	80	80	80	160	160
Maximum Terminal Voltage	VDC	72	72	72	104	104	137	137	205	205
Motor Constant	N-m/√W oz-in/√W	0.042 5.9	0.063 9.0	0.084 11.1	0.10 14.0	0.14 20.7	0.17 26.1	0.37 53.2	0.40 58.1	0.79 113
MECHANICAL SPECIFICATIONS										
Frame Size	NEMA	23	23	23	34	34	42	42	56	56
Motor Weight Without Tach	kg lb	0.8 1.7	1.2 2.5	1.6 3.5	2.4 5.3	3.7 8.1	4.1 9.0	6.0 13.3	10.0 22.0	15.5 34.0
Motor Weight With Tach	kg lb	1.2 2.5	1.6 3.5	2.1 4.5	3.3 7.3	4.6 10.1	5.2 11.5	7.2 15.8	11.5 25.5	17.0 37.5
Shaft Radial Load (Max) at Max Speed	N lb		44 10			89 20		134 30		178 40

ROTARY MOTORS

AEROTECH ADVANTAGES



1000 Series DC motors are manufactured to ISO9001 standards.



Aerotech has extensive in-house design and manufacturing capabilities. Custom configurations are available for all products.

AEROTECH ADVANTAGES



The 1000 Series DC motors can be teamed with Aerotech's BA series amplifiers for a performance-matched system.



1000 Series Rotary Motor Performance

1017

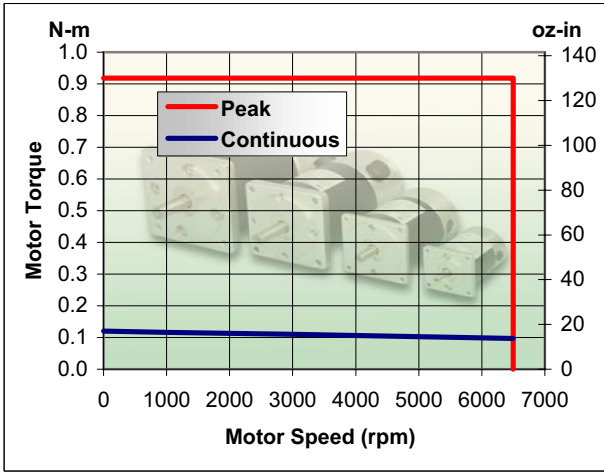

1035

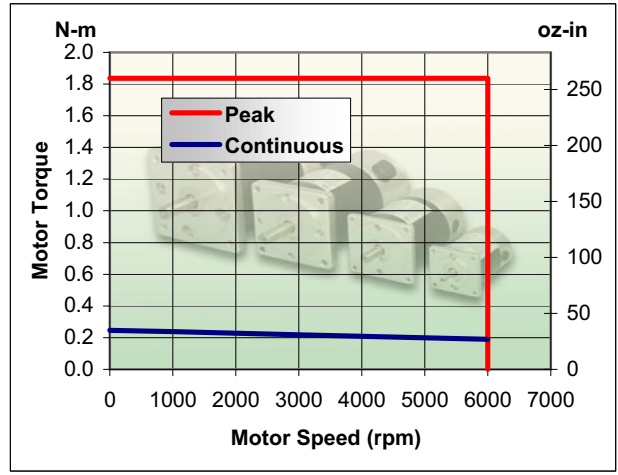

1050

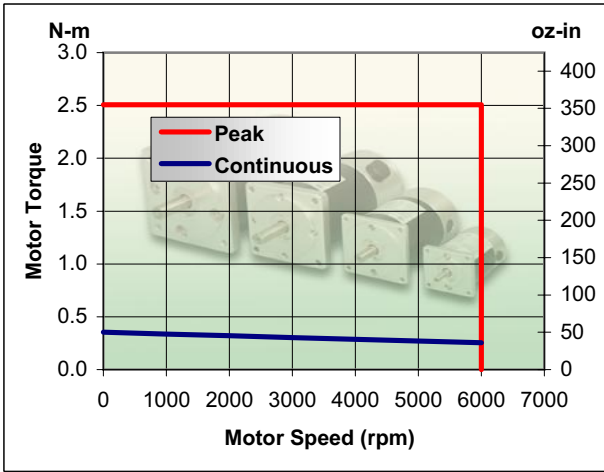

1075

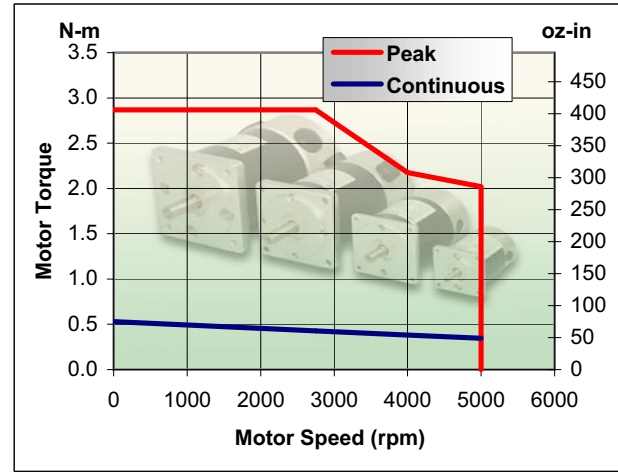

1135

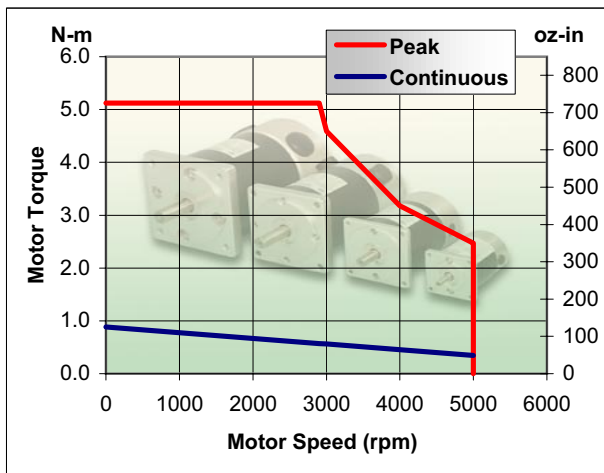

1210

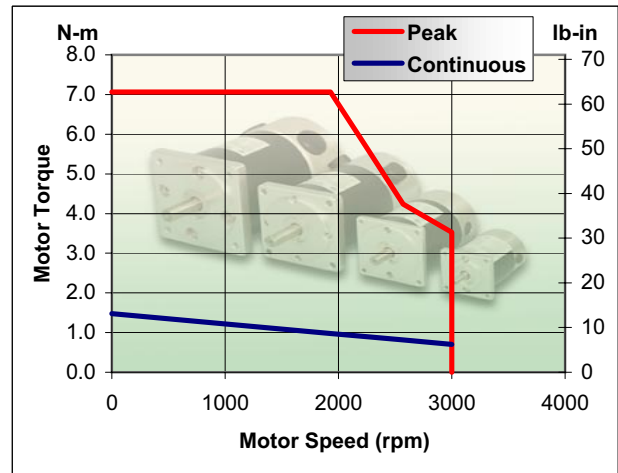

1000 Series Rotary Motor Performance / Dimensions

1410

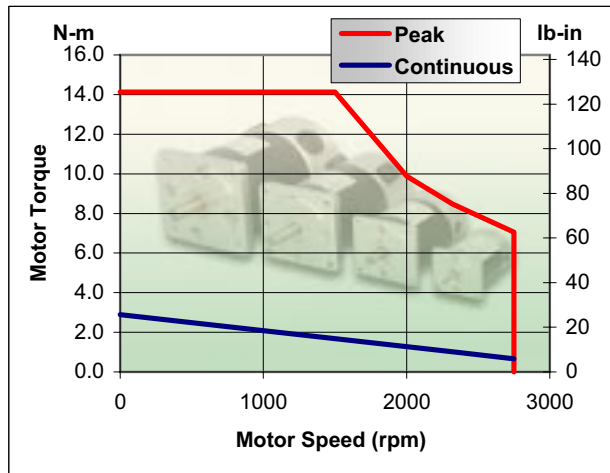

1580

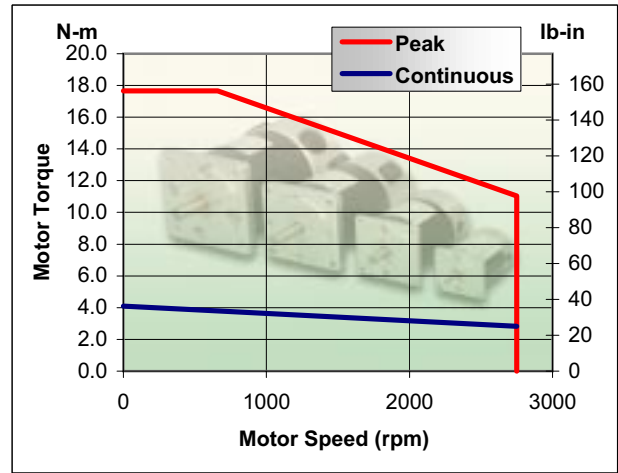

1960

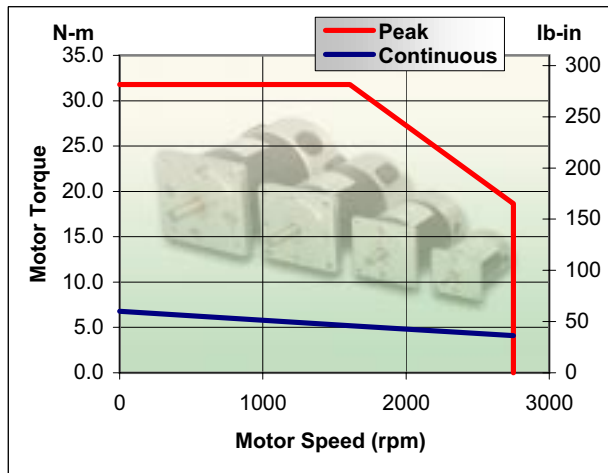

ROTARY MOTORS

NEMA 23

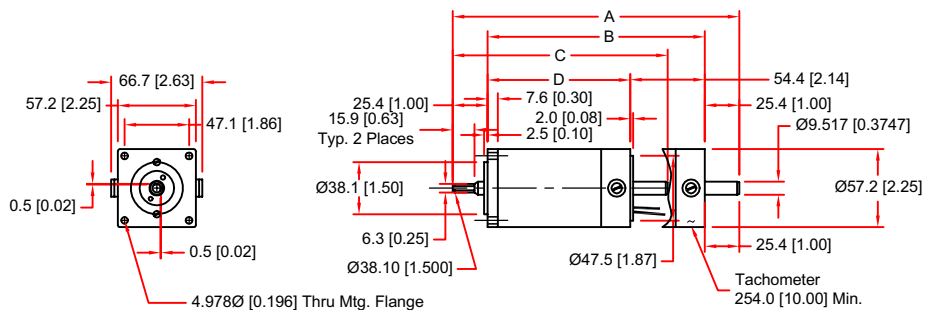

Model Name	Dimensions - Millimeters [Inches]			
	A	B	C	D
1017LT	-	-	136.7 [5.38]	83.8 [3.30]
1035LT	-	-	157.2 [6.19]	104.4 [4.11]
1050LT	-	-	177.5 [6.99]	124.7 [4.91]
1017DC	189.2 [7.45]	139.2 [5.45]	-	-
1035DC	209.6 [8.25]	158.2 [6.25]	-	-
1050LT	229.5 [9.05]	178.5 [7.05]	-	-



This CAD can be downloaded from our web site.



1000 Series Rotary Motor Dimensions

NEMA 34

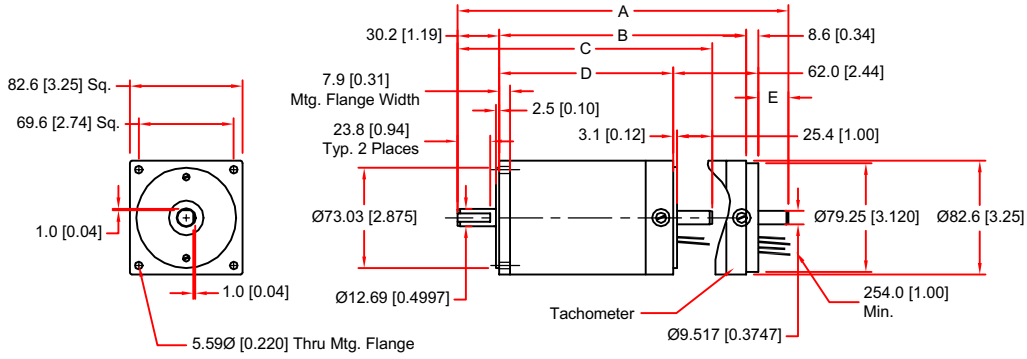

Model Name	Dimensions - Millimeters [Inches]				
	A	B	C	D	E
1075DC	242.5 [9.47]	177.3 [6.98]	-	-	24.4 [0.96]
1135DC	278.1 [10.95]	215.4 [8.48]	-	-	23.9 [0.94]
1075LT	-	-	182.6 [7.19]	124.0 [4.88]	-
1135LT	-	-	220.7 [8.69]	162.1 [6.38]	-



This CAD can be downloaded from our web site.

NEMA 42

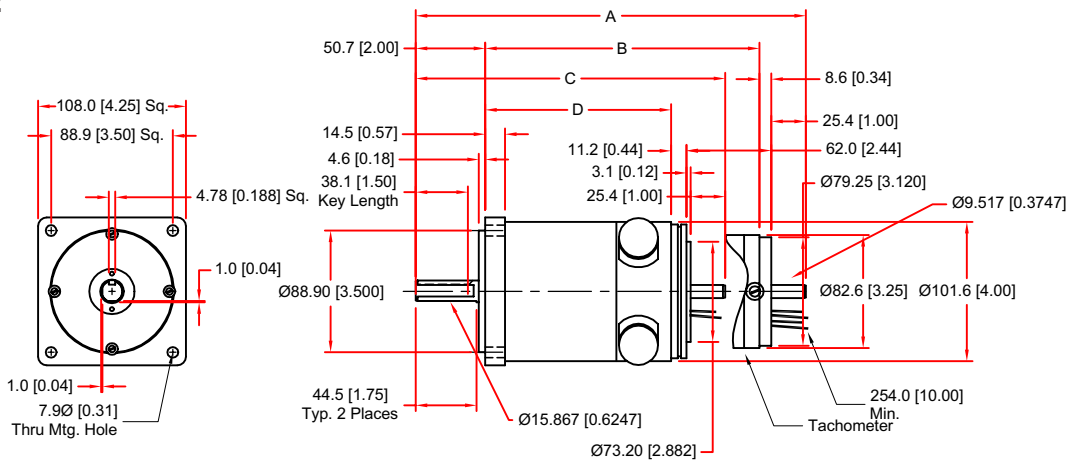

Model Name	Dimensions - Millimeters [Inches]			
	A	B	C	D
1210DC	285.0 [11.22]	200.2 [7.88]	-	-
1410DC	323.1 [12.72]	238.3 [9.38]	-	-
1210LT	-	-	226.1 [8.90]	135.6 [5.34]
1410LT	-	-	263.9 [10.39]	173.7 [6.84]



This CAD can be downloaded from our web site.

NEMA 56

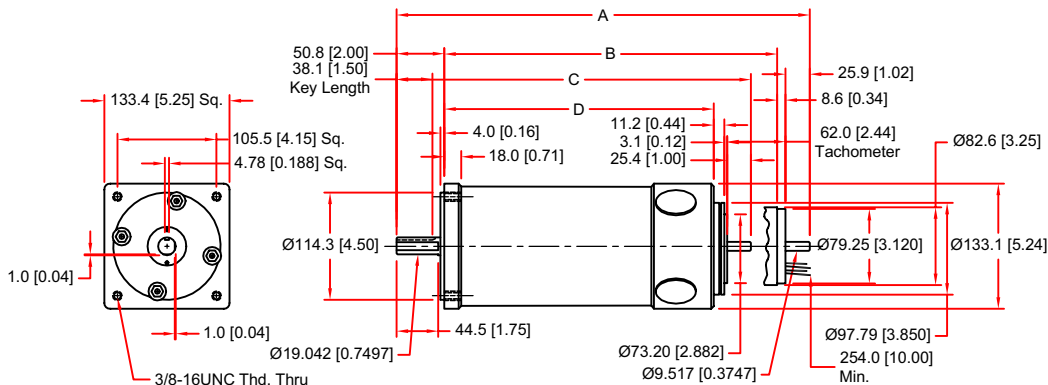

Model Name	Dimensions - Millimeters [Inches]			
	A	B	C	D
1580DC	355.6 [14.00]	270.3 [10.64]	-	-
1960DC	436.9 [17.20]	351.5 [14.86]	-	-
1580LT	-	-	296.2 [11.66]	205.7 [8.10]
1960LT	-	-	377.4 [14.86]	287.0 [11.30]



This CAD can be downloaded from our web site.



1000 Series Rotary Motor Connection and Termination Options

NEMA 23 Motor Cans



This CAD can be downloaded from our web site

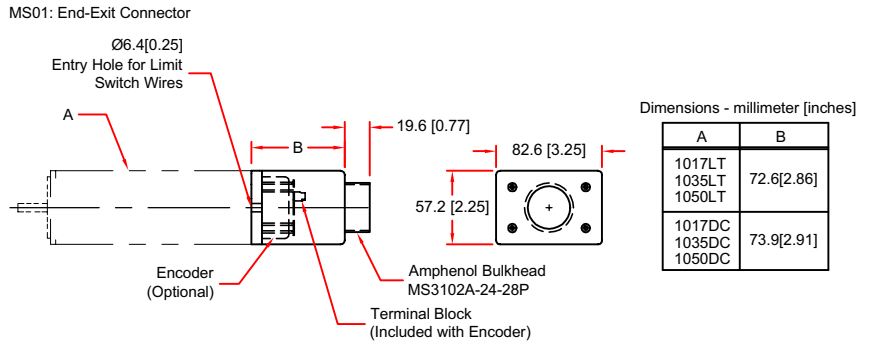

MS0F: Side-Exit Connector

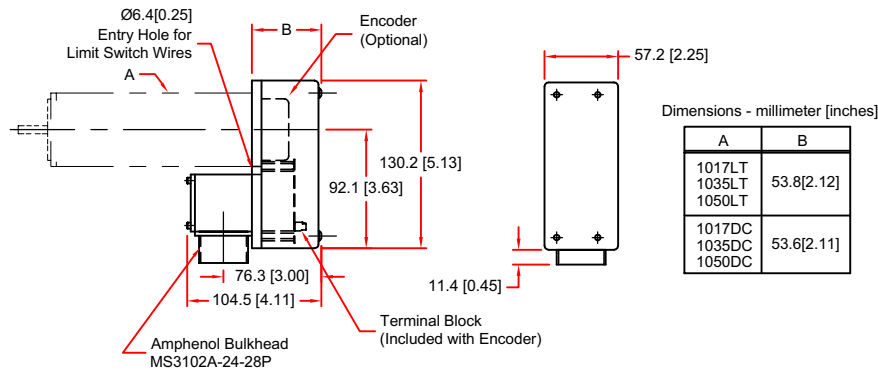

DC2: Side-Exit Integral Connector

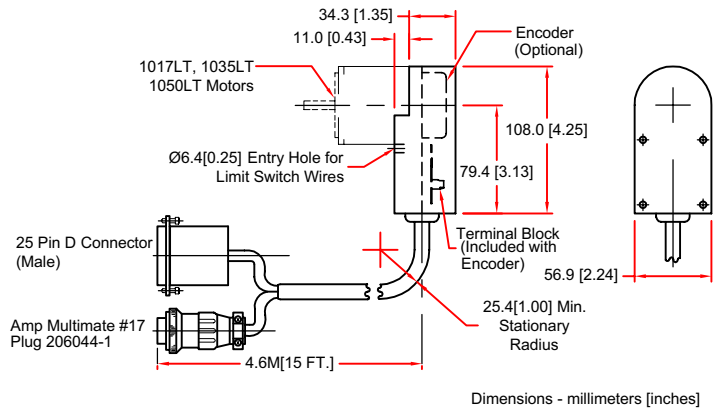

DC2E: End-Exit Integral Connector

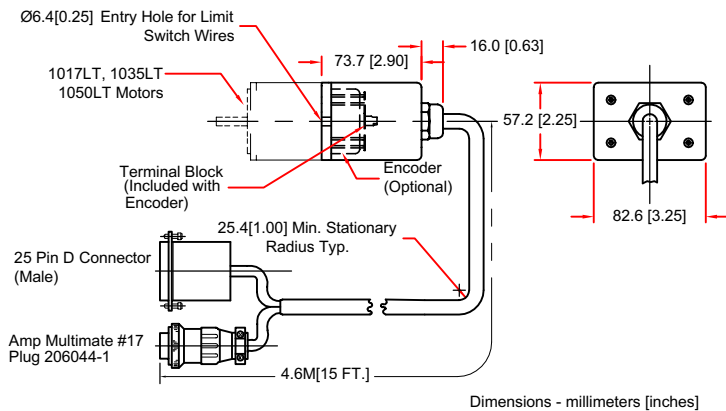

This CAD can be downloaded from our web site

ROTARY MOTORS



1000 Series Rotary Motor Connection and Termination Options

NEMA 34 Motor Cans



This CAD can be downloaded from our web site.

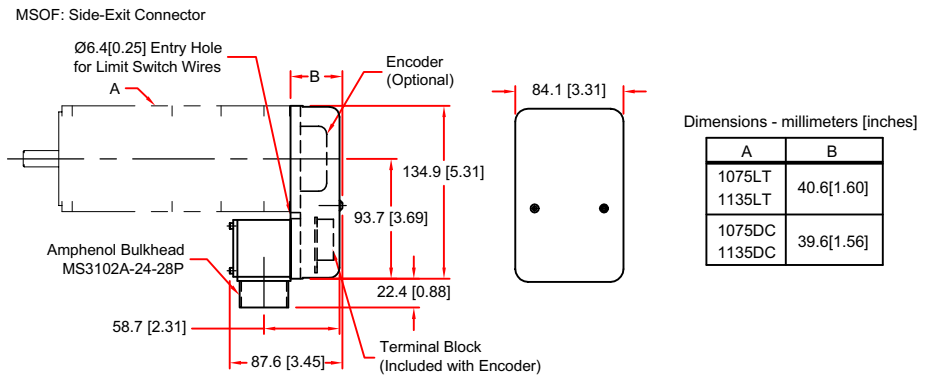
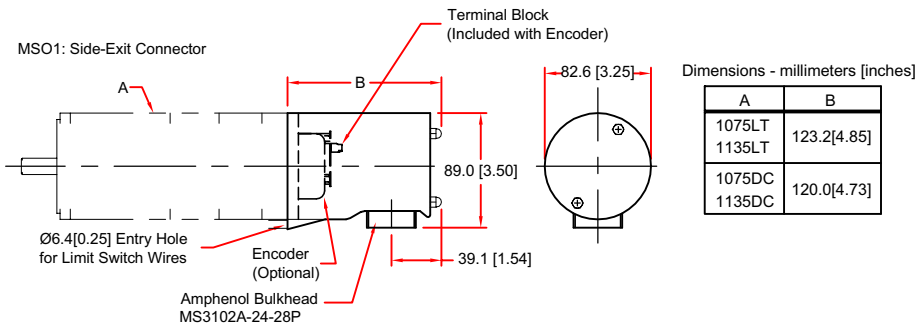

DC3: Side-Exit Integral Connector

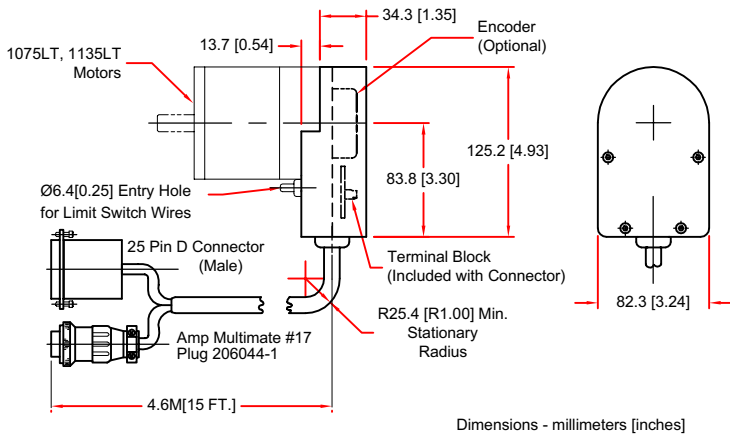

DC3E: End-Exit Integral Connector

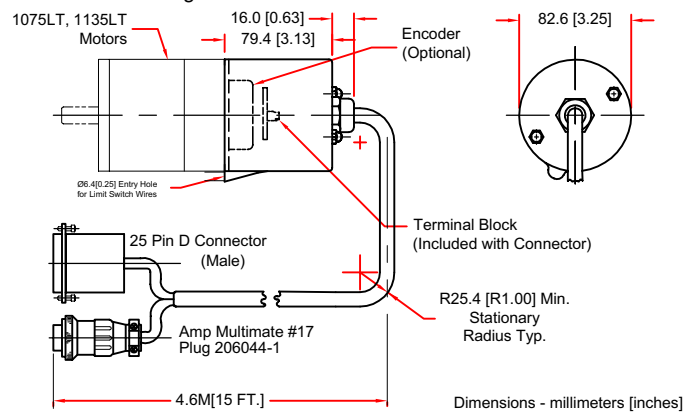

This CAD can be downloaded from our web site.



1000 Series Rotary Motor Connection and Termination Options

NEMA 42 Motor Cans



MSO1: Side-Exit Connector

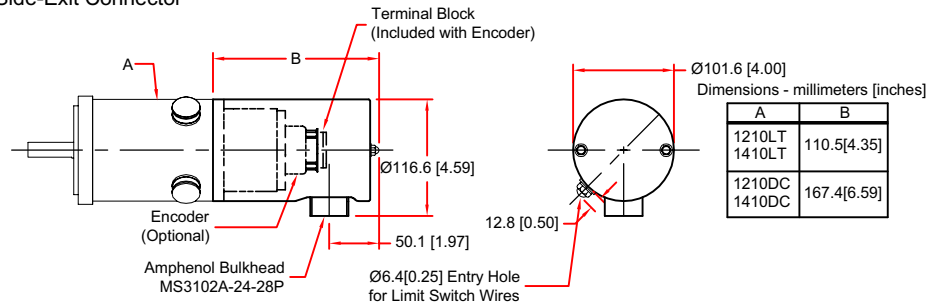

MST: Side-Exit Conduit Fitting

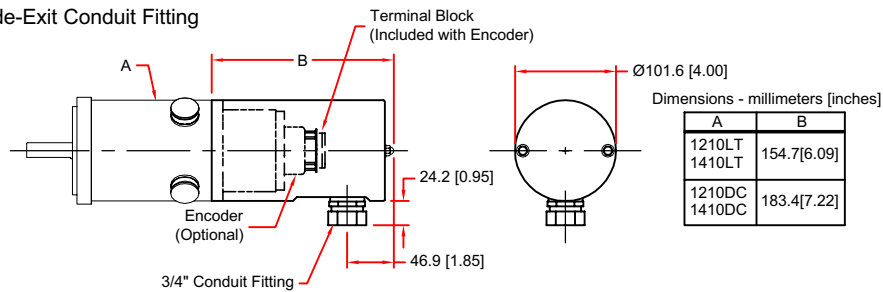

NEMA 56 Motor Cans



MSO1: Side-Exit Connector

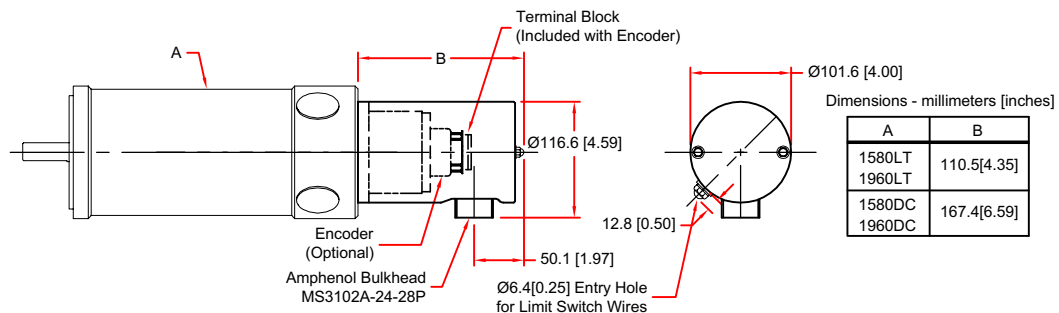

MST: Side-Exit Conduit Fitting

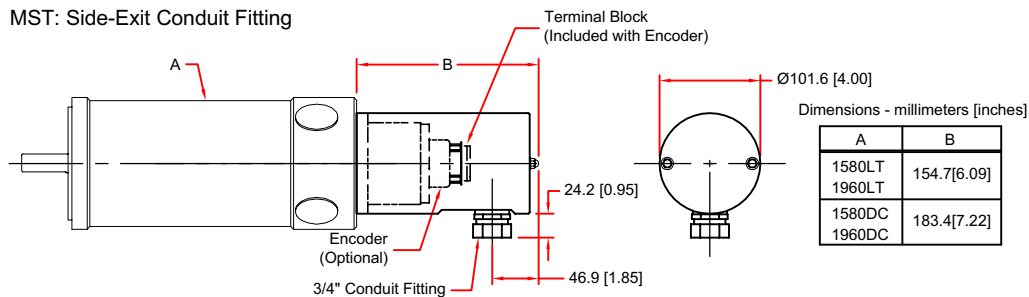

1000 Series Rotary Motor Ordering Information

PART NUMBER AND ORDERING EXAMPLE: 1135DC-MSOF-E2000AS (MOTOR & TACHOMETER & ENCODER)

1	135	DC	MSOF	E2000	AS
Model	Motor Size (continuous torque in oz-in)	Tachometer Option	Termination	Encoder Line Count Per Revolution	Encoder Output
1000 Series DC Motors	017, 035, 050, 075, 135, 210, 410, 580, 960	DC = Standard motor and tachometer winding LT = Standard motor winding (no tach)	(none) = Flying leads (std) MSO1 = Encoder can, MS conn, REAR exit for NEMA 23, SIDE exit for NEMA 34 & 42 motors MSOF = Encoder can, MS conn, low-profile SIDE exit MST = Encoder can, conduit fitting, SIDE exit (NEMA 42 & 56 only) DC2 = Encoder can NEMA 23 only, 15' integral cable, motor END exit, plugs into DR500/U511 chassis DC3 = Same and DC2 for NEMA 34 DC3E = Same as DC2E for NEMA 34 W100 = Wires DC2, DC3, DC2E, DC3E for U100 connection	200, 500, 1000 (std), 1250, 2000	LD = RS-422 line driver (std) AS = Amplifier sine wave

DC Permanent Magnet Servomotors

2 1/4" Diameter, NEMA 23 Models

1017LT	Tcont=0.12 N-m (17 oz-in) DC servomotor
1017DC	Tcont=0.12 N-m (17 oz-in) DC servomotor with 3V/krpm tachometer
1035LT	Tcont=0.25 N-m (35 oz-in) DC servomotor
1035DC	Tcont=0.25 N-m (35 oz-in) DC servomotor with 3V/krpm tachometer
1050LT	Tcont=0.35 N-m (50 oz-in) DC servomotor
1050DC	Tcont=0.35 N-m (50 oz-in) DC servomotor with 3V/krpm tachometer

Options (NEMA 23 Models)

-E200AS - E1000AS	Encoder, 3 channel, amplified sine output
-E2000AS	High density encoder, 3 channel, amplified sine output
-E200LD - E1000LD	Encoder, 3 channel, line driver output
-E2000LD	High density encoder, 3 channel, line driver output
-DC2	Rear housing, side-exit integral cable with connector (LT motor only)
-DC2E	Rear housing, end-exit integral cable with connector
-MSO1	Rear housing, end-exit connector
-MSOF	Rear housing, side-exit connector
-VAC	Vacuum preparation of motor or motor-tach to 10E-6 Torr
-02 or -03	Non-standard tachometer winding

3 1/4" Diameter, NEMA 34 Models

1075LT	Tcont=0.53 N-m (75 oz-in) DC servomotor
1075DC	Tcont=0.53 N-m (75 oz-in) DC servomotor with 3V/krpm tachometer
1135LT	Tcont=0.95 N-m (135 oz-in) DC servomotor
1135DC	Tcont=0.95 N-m (135 oz-in) DC servomotor with 3V/krpm tachometer

1000 Series Rotary Motor Ordering Information

Options (NEMA 34 Models)

-E200AS - E1000AS	Encoder, 3 channel, amplified sine output
-E2000AS	High density encoder, 3 channel, amplified sine output
-E200LD - E1000LD	Encoder, 3 channel, line driver output
-E2000LD	High density encoder, 3 channel, line drive output
-DC3	Rear housing, side-exit integral cable with connector
-MSO1	Rear housing, side-exit connector
-MSOF	Rear housing, right angle low-profile with side-exit connector (shorter than MSO1)
-VAC	Vacuum preparation of motor or motor-tach to 10E-6 Torr
-02 or -03	Non-standard tachometer winding

4" Diameter NEMA 42 Models

1210LT	Tcont=1.48 N-m (210 oz-in) DC servomotor
1210DC	Tcont=1.48 N-m (210 oz-in) DC servomotor with 3V/krpm tachometer
1410LT	Tcont=2.89 Nm (410 oz-in) DC servomotor
1410DC	Tcont=2.89 N-m (410 oz-in) DC servomotor with 3V/krpm tachometer

Options (NEMA 42 Models)

E200AS - E1000AS	Encoder, 3 channel, amplified sine output
E2000AS	High density encoder, 3 channel, amplified sine output
E200LD - E1000LD	Encoder, 3 channel, line driver output
E2000LD	High density encoder, 3 channel, line driver output
-MSO1	Rear housing, side-exit connector
-MST	Rear housing, side-exit conduit fitting
-VAC	Vacuum preparation of motor or motor-tach to 10E-6 Torr
-02 or -03	Non-standard tachometer winding

5.25" Diameter NEMA 56 Models

1580LT	Tcont=4.1 N-m (580 oz-in) DC servomotor
1580DC	Tcont=4.1 N-m (580 oz-in) DC servomotor with 3V/krpm tachometer
1960LT	Tcont=6.8 N-m (960 oz-in) DC servomotor
1960DC	Tcont=6.8 N-m (960 oz-in) DC servomotor with 3V/krpm tachometer

Options (NEMA 56 Models)

E200AS - E1000AS	Encoder, 3 channel, amplified sine output
E2000AS	High density encoder, 3 channel, amplified sine output
E200LD - E1000LD	Encoder, 3 channel, line driver output
E2000LD	High density encoder, 3 channel, line driver output
-MSO1	Rear housing, side-exit connector
-MST	Rear housing, side-exit conduit fitting
-VAC	Vacuum preparation of motor or motor-tach to 10E-6 Torr
-02 or -03	Non-standard tachometer winding



We constantly improve the quality and performance of our products. Please check our web site for the most current specifications.

