

2.094
FINITE ELEMENT ANALYSIS OF SOLIDS AND FLUIDS
SPRING 2008

Homework 5

Instructor: Prof. K. J. Bathe
TA: Do-Nyun Kim

Assigned: 03/06/2008
Due: 03/13/2008

Problem 1 (10 points):

Exercise 4.39 in the textbook, page 297.

Problem 2 (10 points):

Exercise 4.42 in the textbook, page 298.

Problem 3 (20 points):

Consider the problem shown below.

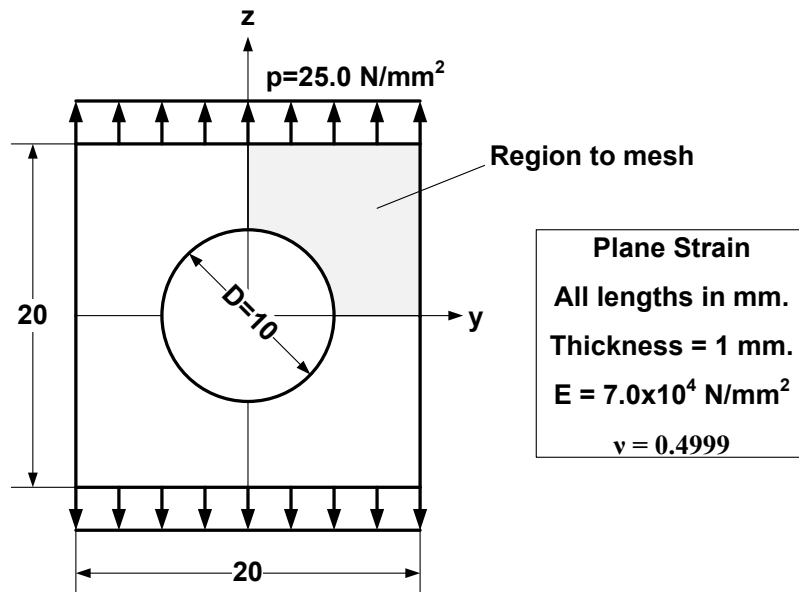

(Case 1) Use the displacement-based 4-node and 9-node elements and establish convergence curves for these elements. Thus establish the rates of convergence.

(Case 2) Use the mixed 4/1 and 9/3 u/p elements and establish convergence curves for these elements. Thus establish the rates of convergence.

In both cases, also plot the pressures on the coarsest meshes you have used.

Try to use reasonably refined meshes to obtain the optimal convergence rate. Your starting 4-node element mesh may be as shown below.

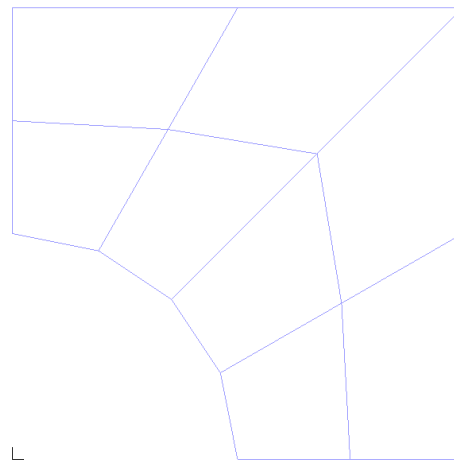

Use as the exact strain energy **E= 0.8019875218E+00** which is obtained using 20,000 9-node u/p elements.

Notes:

* You can obtain the strain energy from .OUT file after calculations.

* When you define an element group,

1) set “Incompatible Modes” to “No” in kinematic formulation tab.

2) set “Type” in “Interpolation Formulation” to “Displacement” for the displacement-based elements
to “Mixed” for the u/p elements.