

Thermoforming of thermoplastic sheets

2.810

T. Gutowski

Vacuum Thermoforming

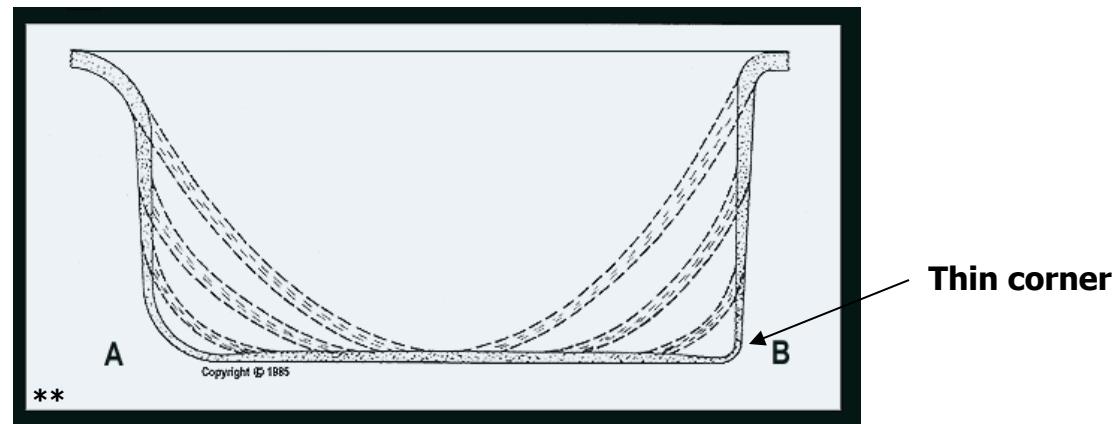
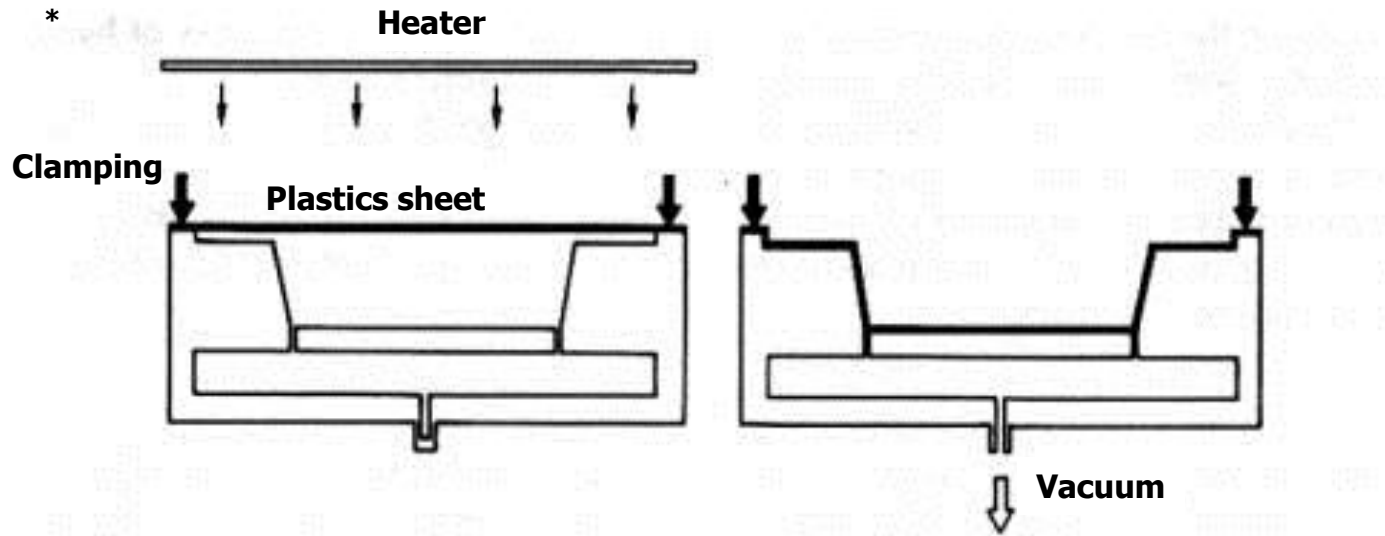

Thermoformed Parts



Some Basics

1. Heating and cooling
2. Viscoelastic behavior
 - Rubber elasticity
 - Time-Temperature behavior
3. Deformation patterns
4. Production equipment
5. Double diaphragm forming

Heat Transfer in Thermoforming

Heating

$$\dot{q} = \sigma T^4$$

Stefan's eq'n black body radiation

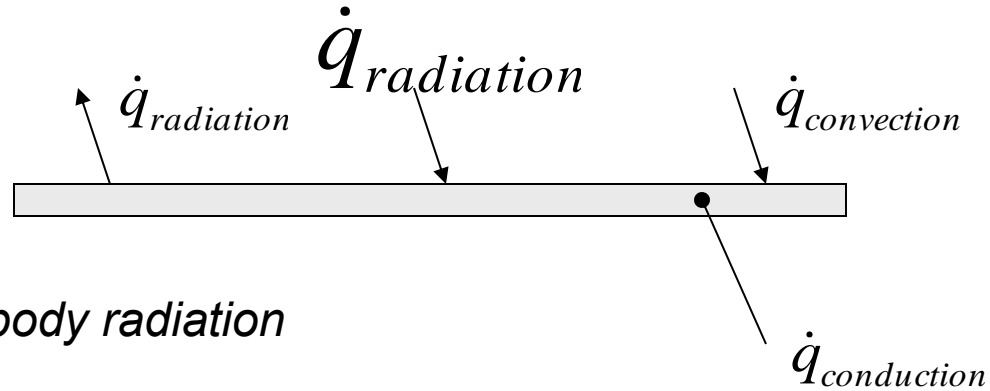

Cooling

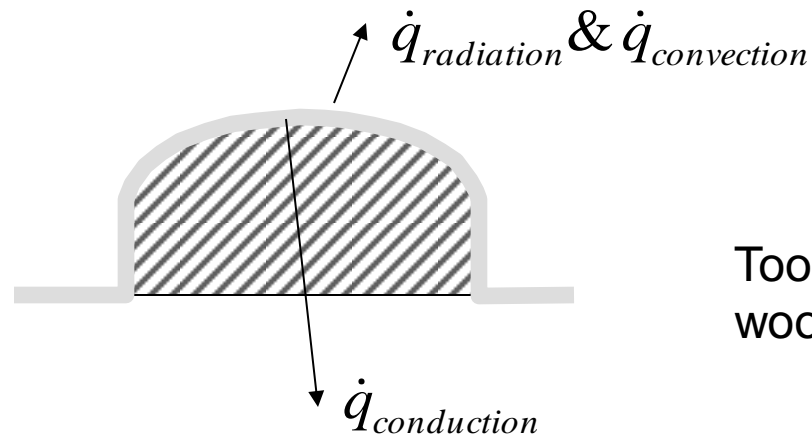

Tooling materials -
wood etc to aluminum

Radiation Heat Transfer between two parallel plates

$$\dot{q} = \frac{1}{\frac{1}{\epsilon_1} + \frac{1}{\epsilon_2} - 1} \sigma (T_1^4 - T_2^4)$$

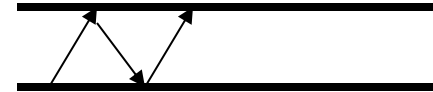

$$\sigma = 5.67 \times 10^{-8} \text{ W/m}^2\text{K}^4$$

$$\epsilon_1 \epsilon_2 = 0.85 \text{ (gray bodies)}$$

$$T_1 = 533^\circ\text{K} \text{ (heater)}$$

$$T_2 = 293^\circ\text{K} \text{ (plastic at room temperature)}$$

$$q = 4.2 \text{ kW/m}^2$$

$$\text{at } T_2 = 180^\circ\text{C} = 453^\circ\text{K} \text{ (forming temperature)}$$

$$q = 2.3 \text{ kW/m}^2$$

See Lienhard Text Ch 10 on Radiation Heat Transfer

Heating Time est. (Kydex sheet)

$$\dot{q} = \rho w c \frac{\Delta T}{\Delta t}$$

Given the flux at the face,
how long to raise temp of
sheet to forming temp?
Lumped parameter model

$$\rho = 1.35 \text{ g/cm}^3$$

$$w = 1/16 \text{ in or } 1.59 \text{ mm}$$

$$c = 1.21 \text{ J/g}^\circ\text{K}$$

$$\Delta T = 180 - 20 = 160^\circ\text{K}$$

$$\Delta t = 130 \text{ sec}$$

Temperature regimes for polymers

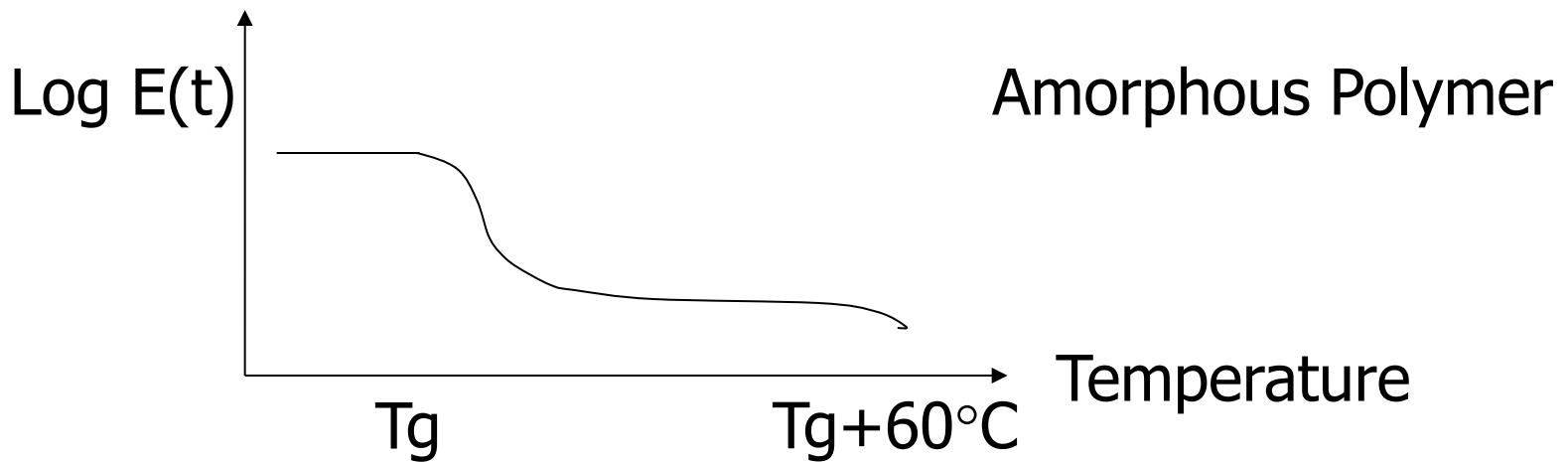
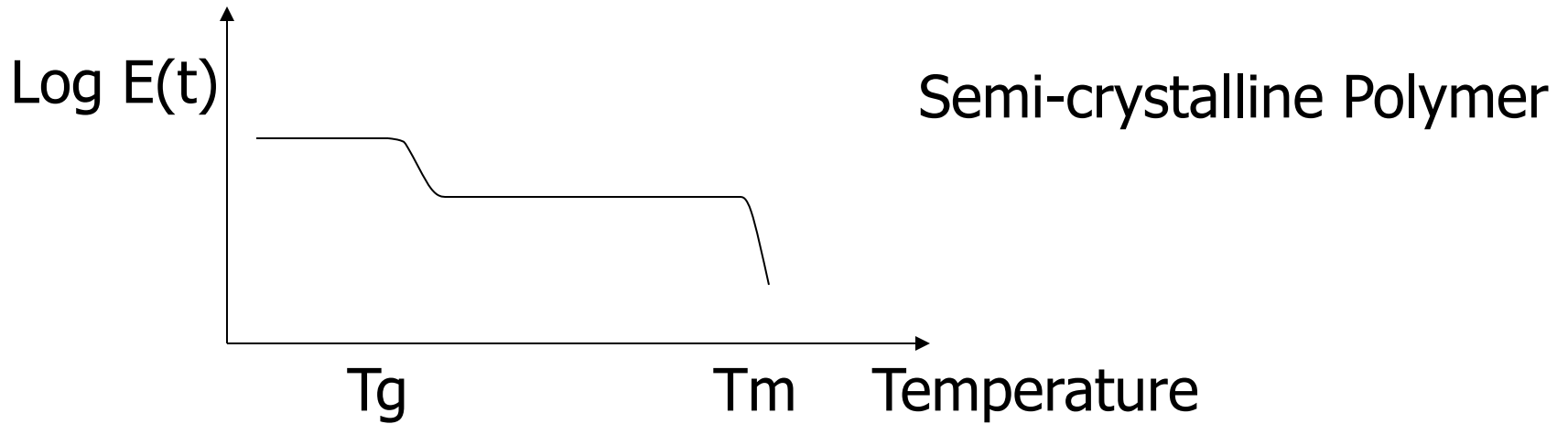

Viscous behavior of “silly putty”



Simple Viscoelastic System

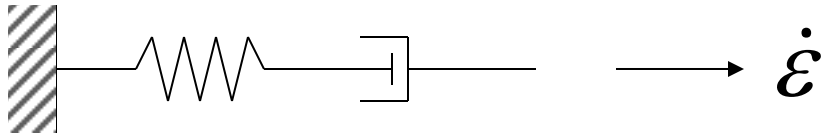

Force Equilibrium: $\sigma_s = \sigma_d = \sigma$

Kinematic compatibility: $\dot{\epsilon}_s + \dot{\epsilon}_d = \dot{\epsilon}$

Constitutive behavior: $\sigma_s = E\epsilon_s; \sigma_d = \mu\dot{\epsilon}_d$

This gives
$$\frac{\mu}{E} \dot{\sigma} + \sigma = \mu\dot{\epsilon}$$

The viscoelastic Time constant is :

$$\lambda = \frac{\mu}{E} = \frac{\text{"Newtonian" Viscosity}}{\text{Elastic Modulus}}$$

Solution to : $\lambda \dot{\sigma} + \sigma = \mu \dot{\varepsilon}$ with I.C. $\sigma = 0$ at $t = 0$

$$\sigma = \mu \dot{\varepsilon} (1 - e^{-t/\lambda})$$

Large values of t / λ i.e. $t \gg \lambda$

$$\sigma \approx \mu \dot{\varepsilon} \quad \text{viscous behavior}$$

Small values of t / λ i.e. $t \ll \lambda$

$$\sigma \approx \mu \dot{\varepsilon} (1 - (1 - t / \lambda)) = \mu \dot{\varepsilon} t / \lambda$$

let $\dot{\varepsilon} \cdot t = \varepsilon$, this gives

$$\sigma \approx E \varepsilon \quad \text{elastic behavior}$$

"FAST"

$$t \ll \lambda$$

Elastic

"SLOW"

$$t \gg \lambda$$

Viscous

"INBETWEN"

$$t \sim \lambda$$

Viscoelastic

Viscoelastic Effects During processing

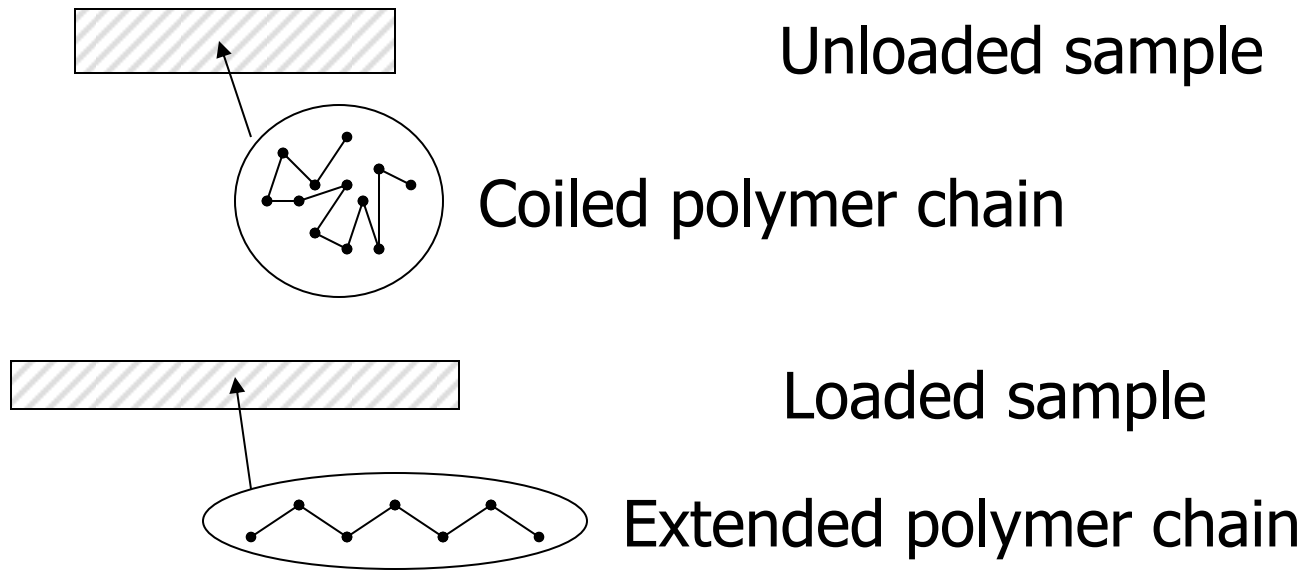

Polymer chains tend to exist in coiled configurations. Loading the sample can extend the chain and alter the mechanical behavior. Generally, abrupt, high rates of loading will extend the chain and lead to elastic effects. On the other hand, gradual slow rates of loading allow the chain to more or less retain its coiled configuration, with a resulting primarily viscous response

Simplified Rubber Elasticity

(No volume change)

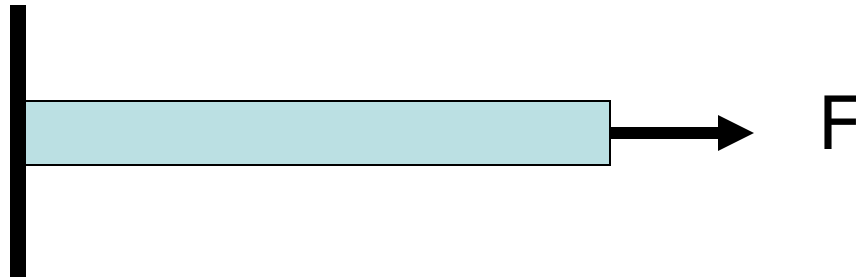

$$\Delta W = F \Delta L = \Delta A = \Delta E - T \Delta S$$

(A = Helmholtz free energy)

- Conventional materials

$$F = \Delta E / \Delta L$$

- Rubber

$$F = -T (\Delta S / \Delta L)$$



QuickTime™ and a decompressor are needed to see this picture.

Flory

note that upon extension the change in entropy is negative

Temp. Dependence of Time constant, λ

$$\lambda = \frac{\mu}{E} \cong \frac{\mu_0 e^{\Delta E/RT}}{E_0 T}$$

← Arrhenius
← Rubber elasticity

Approximation $\lambda \cong \lambda_0 e^{\Delta E/RT}$

(For better accuracy, use Time-Temp shift, WLF eqn.)

Example: PMMA

Temp	λ
40°C	114 yrs
100°C	T_g
135°C	3.5 millisec

deformation patterns

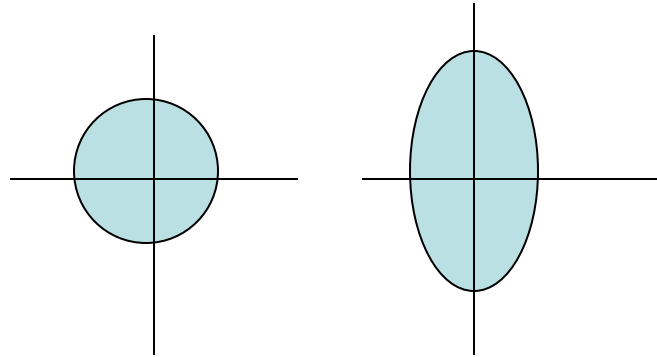

$$d(Ah) = A dh + h dA = 0$$

$$dA/A = - dh/h$$

Deformation Patterns

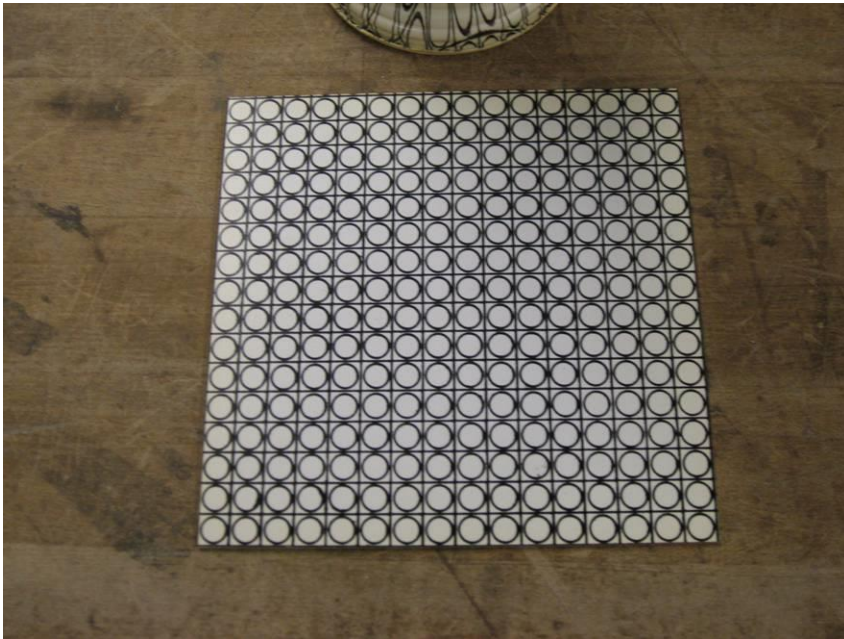

Thermofforming

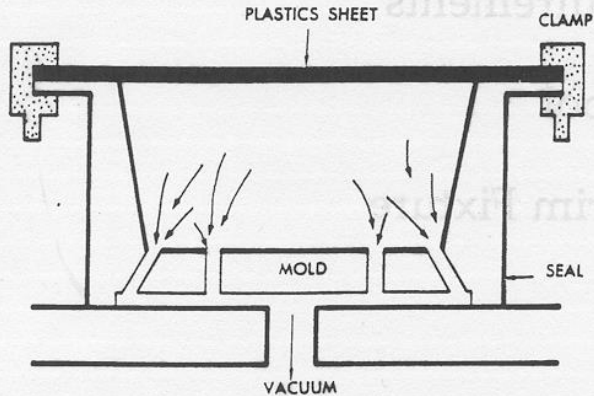

(A) A clamped and heated plastic sheet is forced down into the mold by air pressure after a vacuum is drawn in the mold. (Atlas Vac Machine Co.)

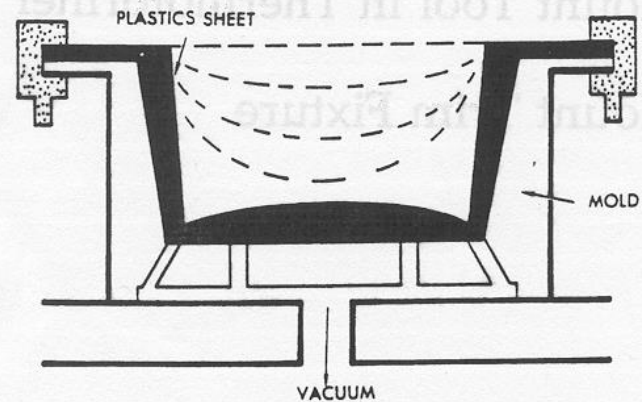

(B) Plastics sheet cools as it contacts the mold. (Atlas Vac Machine Co.)

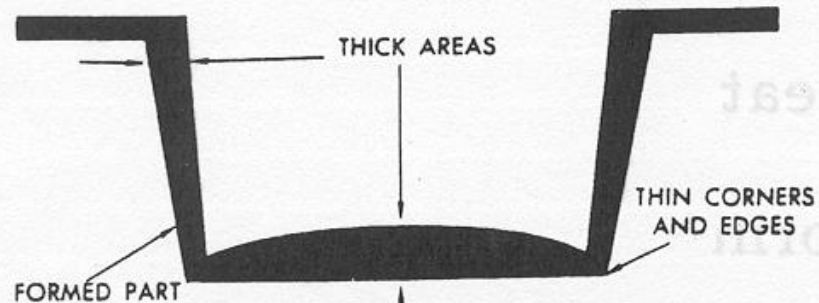

(C) Areas of the sheet that touched the mold last are the thinnest. (Atlas Vac Machine Co.)

Variations on the process

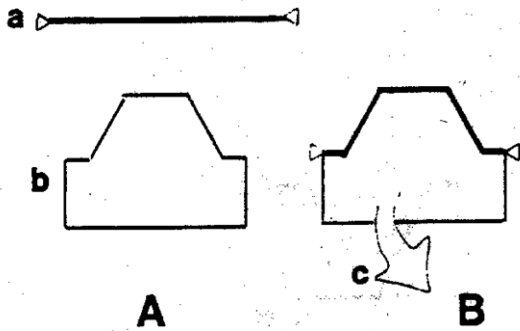

A
B
Drape Forming

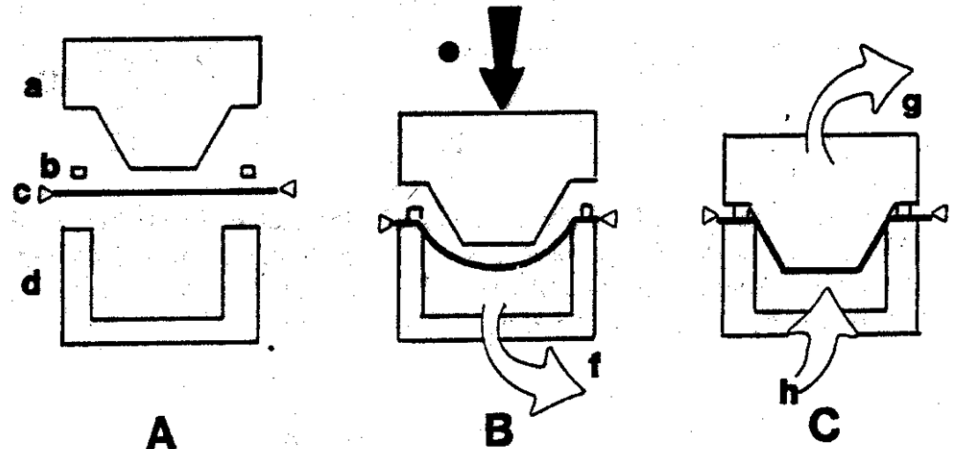

A **B** **C**
Vacuum Snap-Back Forming

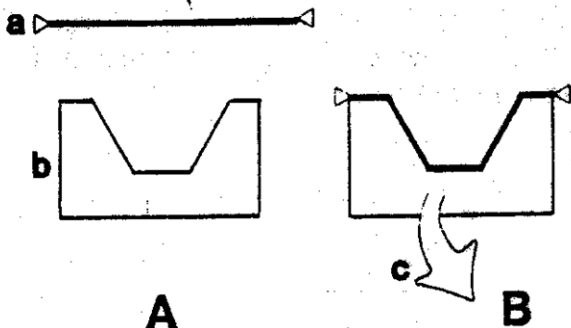

A **B**
Vacuum Forming

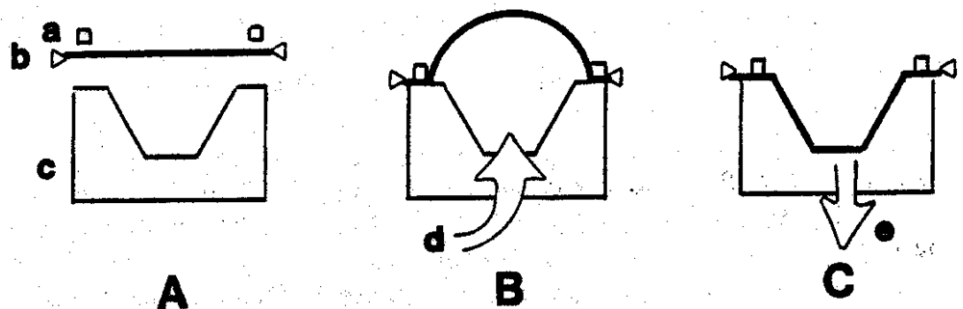

A **B** **C**
Billow Vacuum Forming

Design Issues

- Sharp corners
- Deep draws
- Ribs
- Undercuts
- Draft angles
- Thickness variation

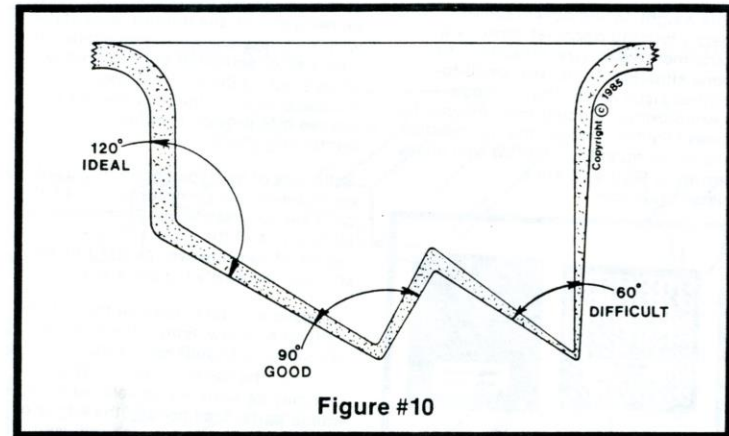

Thermoforming Patterns



Vacuum holes



Variations on the process

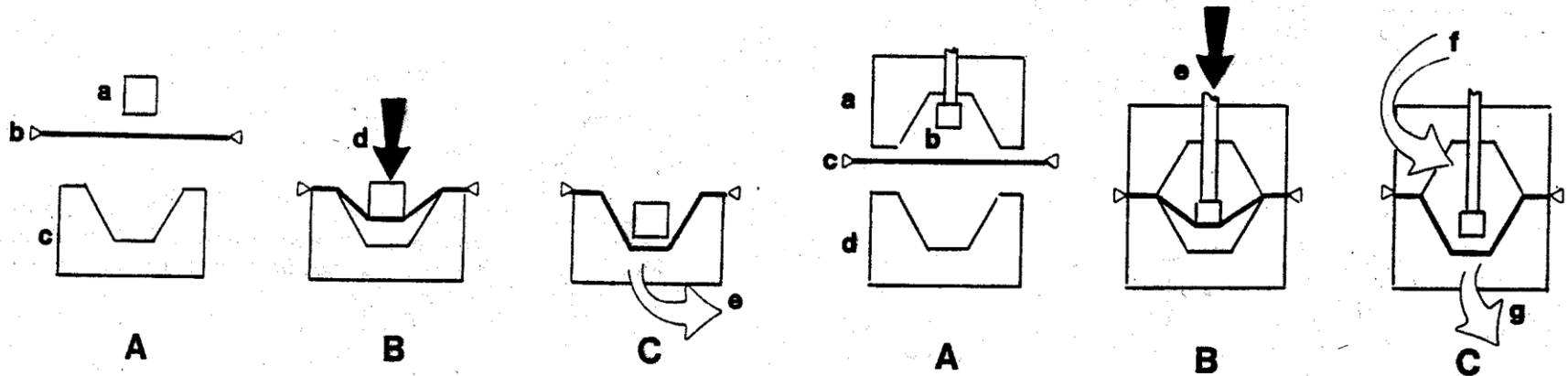

Plug-assist Vacuum Forming

Plug-assist Pressure Forming

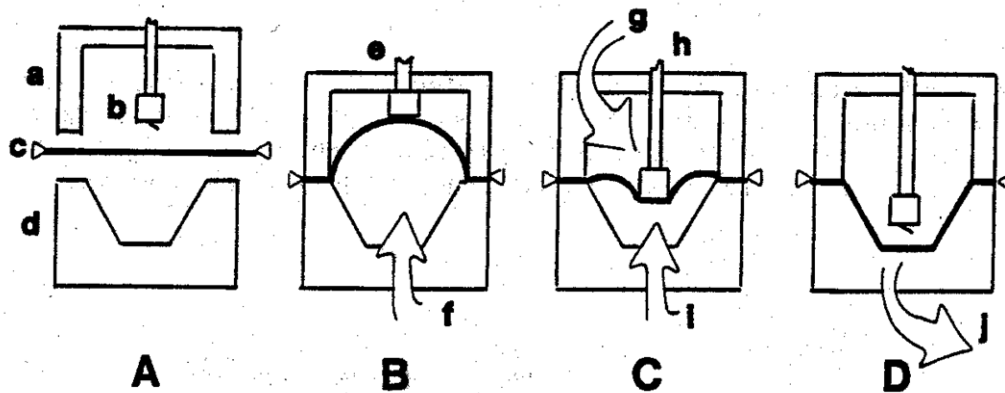

Pressure Reverse Draw with Plug-assisted

Production Equipment

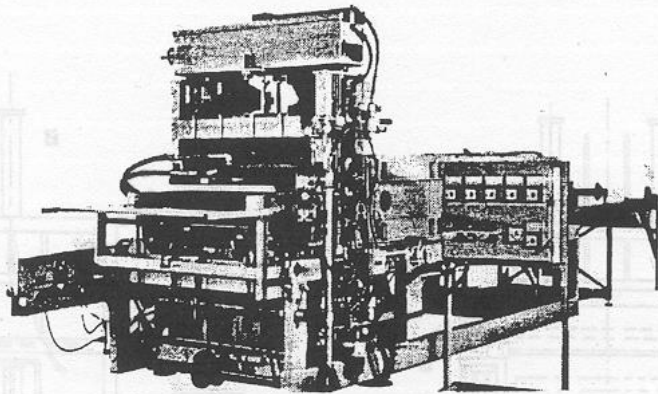

(A) High-speed pressure/vacuum former operates from either roll stock or inline with an extruder.

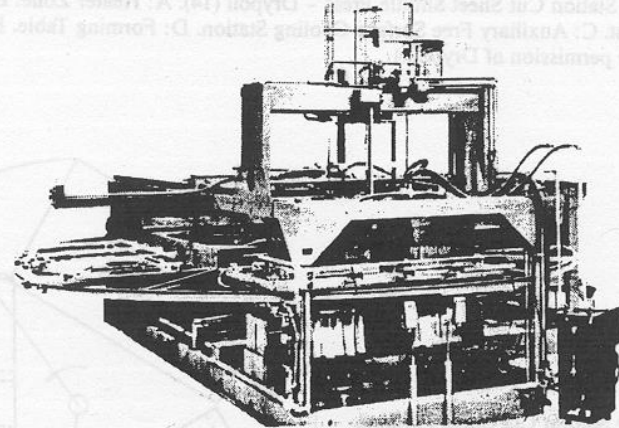

(B) Rotary style of unit used for large industrial components at a fairly high production rate.

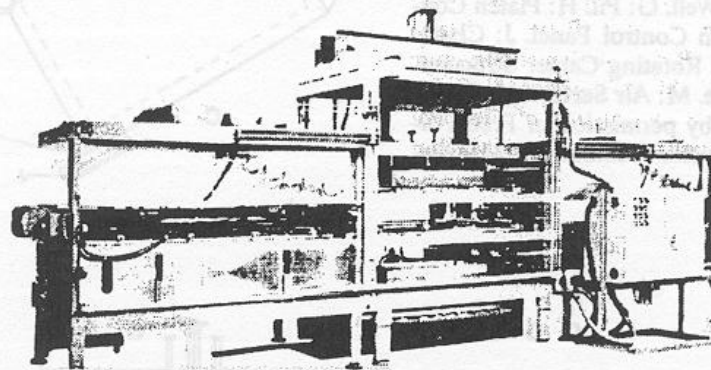

(C) Twin-sheet thermoforming machine with separate, independent clamping frames.

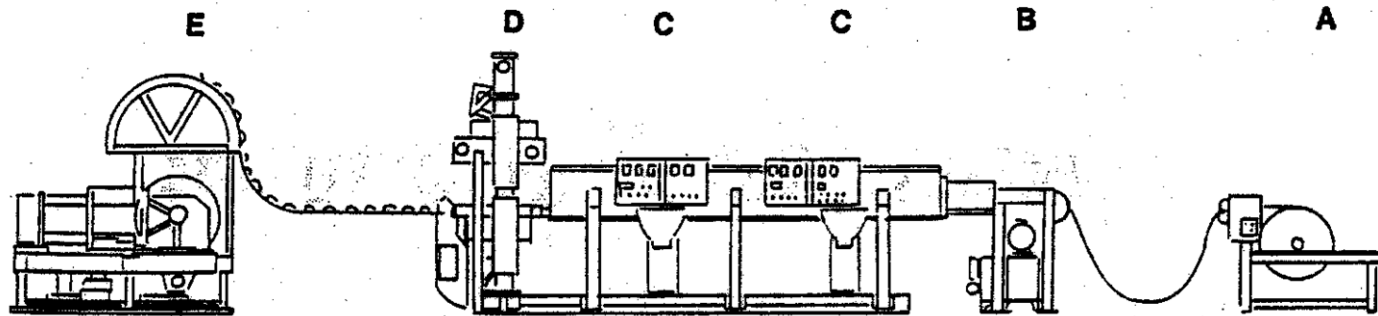

Figure 1.2 Schematic - Battenfeld Gloenco Rollfed Sheet + Thermoforming Line (13). A: Rollfed Sheet Take-off Station. B: Pin Chain Engagement. C: Heater Zone. D: Forming Station. E: In-Line Separate Mechanical Toggle-Clamp Trim Station.

Brown Machine: <http://www.youtube.com/watch?v=hAlqrDiCu-M>

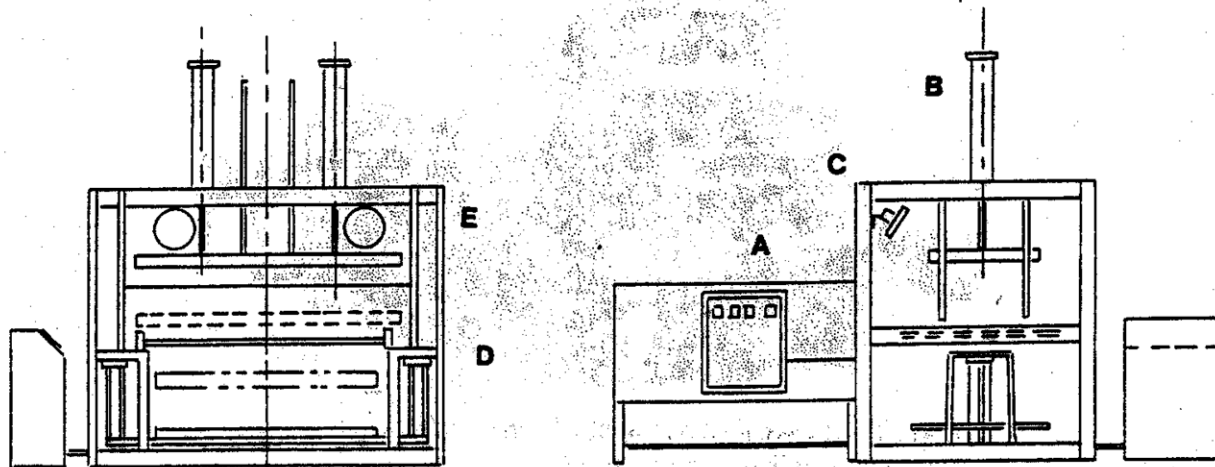

Figure 1.3 Single Station Cut Sheet Shuttle Press - Drypoll (14). A: Heater Zone. B: Pneumatic/Hydraulic Plug Assist. C: Auxiliary Free Surface Cooling Station. D: Forming Table. E: Vacuum Tanks. (Drawing used by permission of Drypoll.)

Figure 1.4 Rotary Station Cut Sheet Forming Press - Custom Automated Machinery (15). A: Heating Station. B: Forming Station. C: Load/Unload Station. D: Drive Center. E: Platen. F: Motor Well. G: Pit. H: Platen Control Panel. I: Oven Control Panel. J: Clamp Control Panel. K: Rotating Center Structure. L: Vacuum Service. M: Air Service. N: Safety Guard. (Drawing by permission of Fred Pollock, President, Custom Automated Machinery, Inc.)

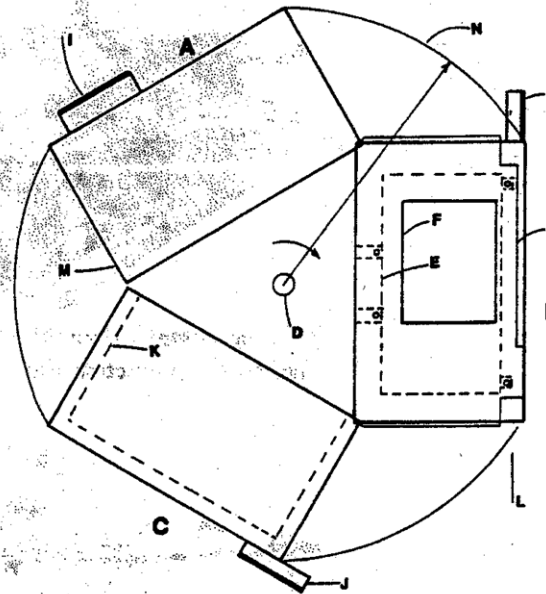

Figure 1.7 In-line Heavy-Gage Sheet Forming System - Shelly (13). A: Extruder. B: Down-Roll Stack and Cooling Table. C: Edge Trim. D: Hold-Down Table. E: Edge Clamp Engagement. F: Sheet Heating Zone. G: Forming Station. H: In-line Trimming Station.

Double Diaphragm Forming

Laminate wrinkling scaling laws: T. G. Gutowski et al.

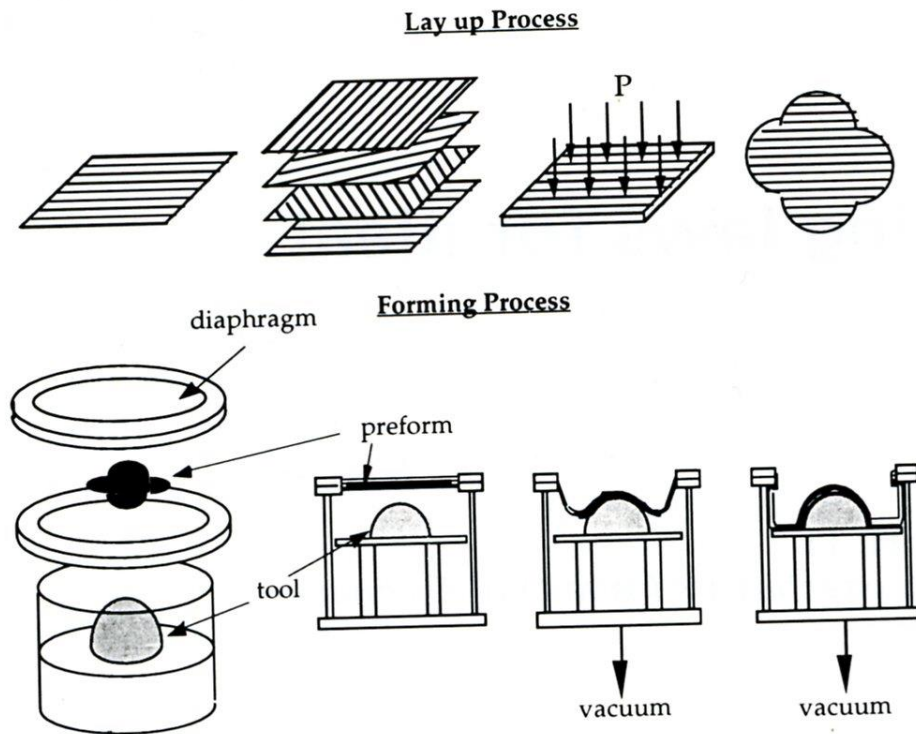

Fig.11 Hemisphere formed between elastic diaphragms

Figure 1 Schematic representation of the diaphragm forming process

Temp, Time, Size & Shear

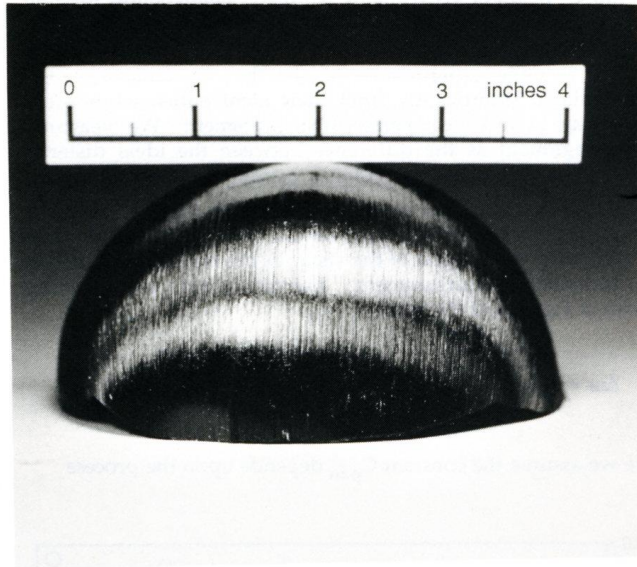

Fig.11 Hemisphere formed between elastic diaphragms

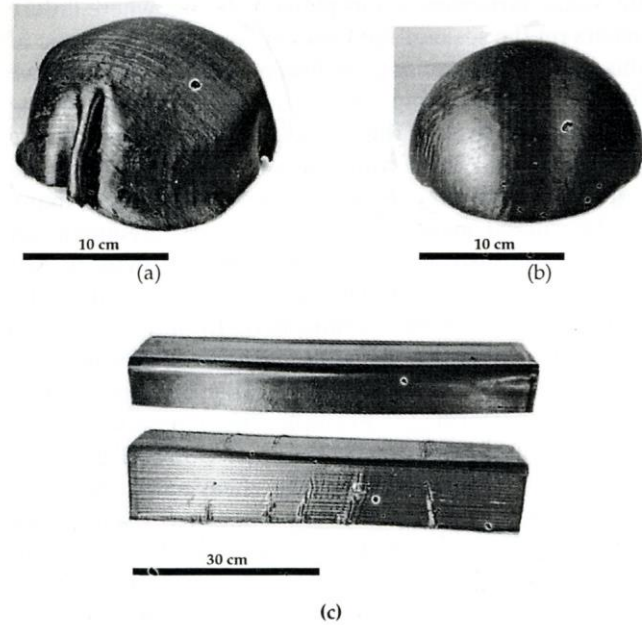

Figure 3 (a) Illustration of laminate wrinkling on a 16-ply $[0/90]$ hemisphere, (b) the same hemisphere formed without wrinkles and (c) laminate wrinkling on a C-channel

Ideal Shear Vs Actual

Laminate wrinkling scaling laws: T. G. Gutowski et al.

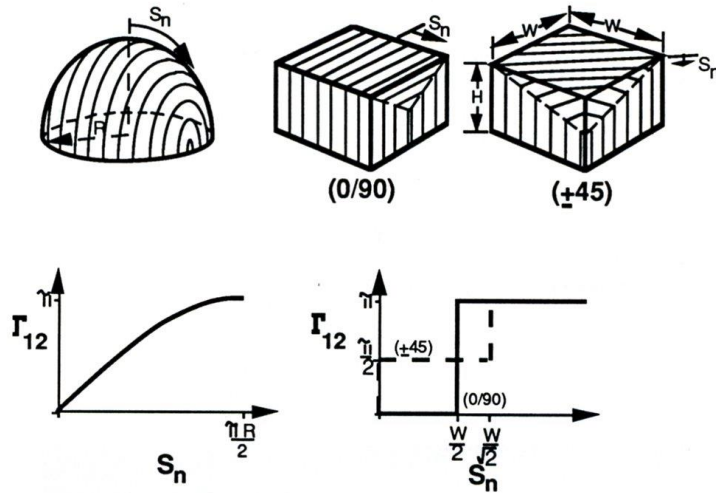

Fig.8 Fiber patterns and shear distributions for boxes and hemispheres

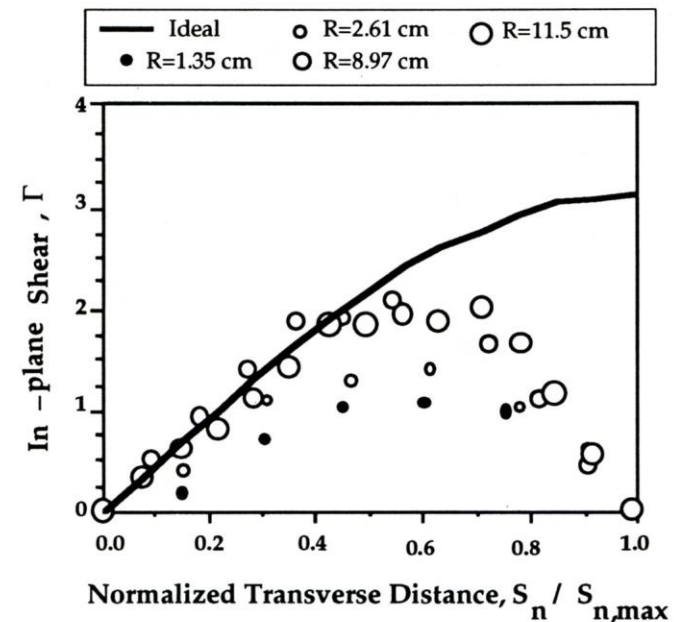

Figure 24 Comparison of ideal fibre and actual fibre shears for [0/90] hemispheres

Parts made in Lab

Laminate wrinkling scaling laws: T. G. Gutowski et al.

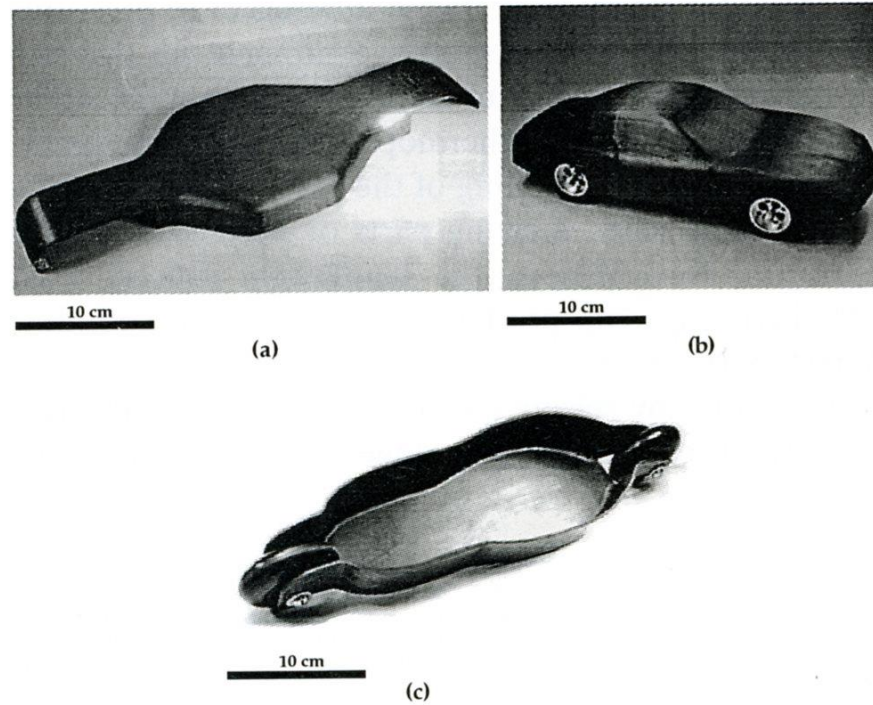
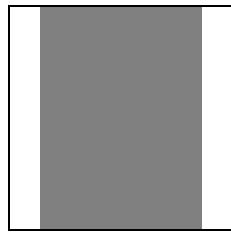
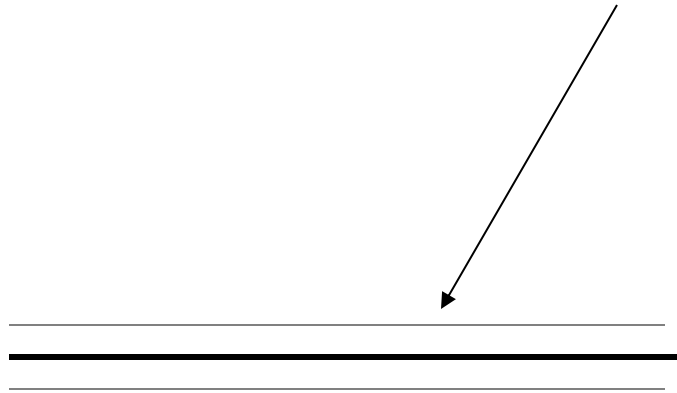

Figure 32 Thermoset matrix parts made by the diaphragm forming process: (a) chassis for a radio-controlled model car, (b) scale-model automotive body and (c) roller blade

Double diaphragm forming



Forming
tool



Curing
tool

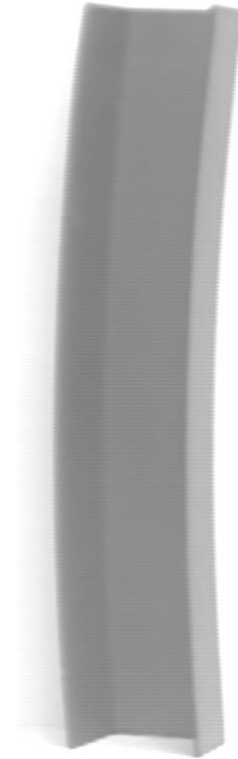

Former MIT grad student Sam Truslow



MIT Building 35



Prototype machine at Boeing

Diaphragm forming of Composites



Demo part for Boeing 377

More videos

<http://www.youtube.com/watch?v=KPF AoLmJ5og>

superplastic forming of aluminum at Kirkham University

<http://www.youtube.com/watch?v=NPLWxxyIJcE&NR=1&feature=fvwp>

thermoforming blow and then vacuum