

Appendix 1 –Two Coupled Oscillators

If the solution is irradiated with light of the proper wavelength, some fraction of the dye molecules in the solution will be promoted to an electronic excited state. The two main processes by which the excited molecules can relax are fluorescence, a process by which the excited dye monomer gives off a photon and returns to the ground state, and interaction with another dye monomer in the ground state. The second of these two processes is much more rapid, and its effect will be considered first. A small number of excited donor molecules are surrounded by a large number of unexcited acceptor molecules. Although these dye molecules are electrically neutral, motion of the electrons results in Coulomb forces acting between the molecules. The result of this interaction is that the excitation can “hop” from donor to acceptor. To completely describe how and why this interaction leads to excitation hopping, it is necessary to examine quantum mechanically the dynamic behavior of interacting electrons (see the textbook by **Cohen-Tannoudji et al. (1977)** for some heavy-duty quantum mechanics). To get a physical feeling for the process, a simple classical model can be used to understand energy hopping in an analogous system, keeping in mind, however, that the details of the interaction are different for molecular excitation transfer.

Imagine the system of springs pictured in Figure A1:

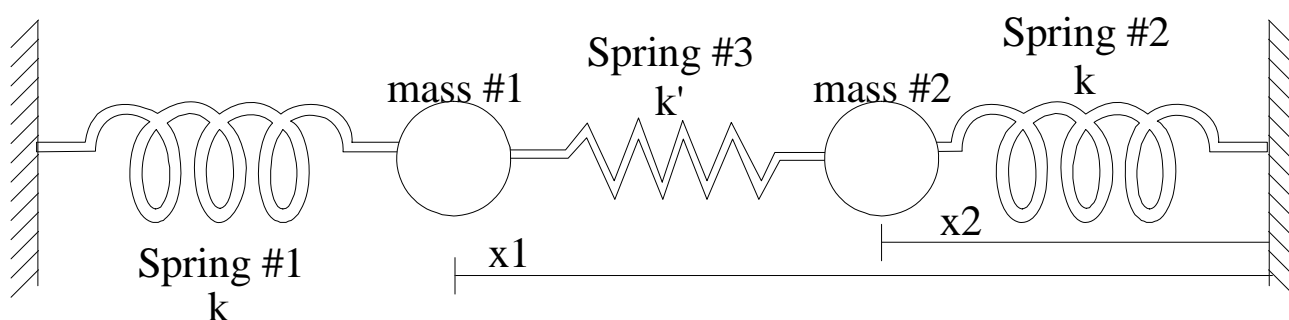

Figure A1:Two coupled oscillators.

Mass #1 represents the donor molecule and mass #2 represents the acceptor. Spring #3 represents an interaction between the two molecules. It is important to realize that this is a drastic oversimplification of the behavior of molecules, but this model still captures the fundamental physics of energy transfer. If mass #1 were pushed and set into motion, mass #2 would not remain stationary while mass #1 oscillated. Figure 3 illustrates the time

dependence of the displacements of the two masses. The displacements of mass #1 (x_1) and mass #2 (x_2) are represented in Figure A2 by the solid and dashed lines respectively. It is seen that the oscillations of mass #1 gradually decrease while the oscillations of mass #2 grow larger until mass #1 is essentially at rest and mass #2 is reaching its maximum displacement. The situation then reverses itself until mass #2 is essentially at rest and mass #1 is reaching its maximum displacement. The energy of the system sloshes back and forth between the oscillations of mass #1 and mass #2. A mathematical treatment of this model is given in appendix B where it is shown that the frequency at which this energy sloshes from one mass to another is proportional to k' , the spring constant of the spring which couples the two masses together.

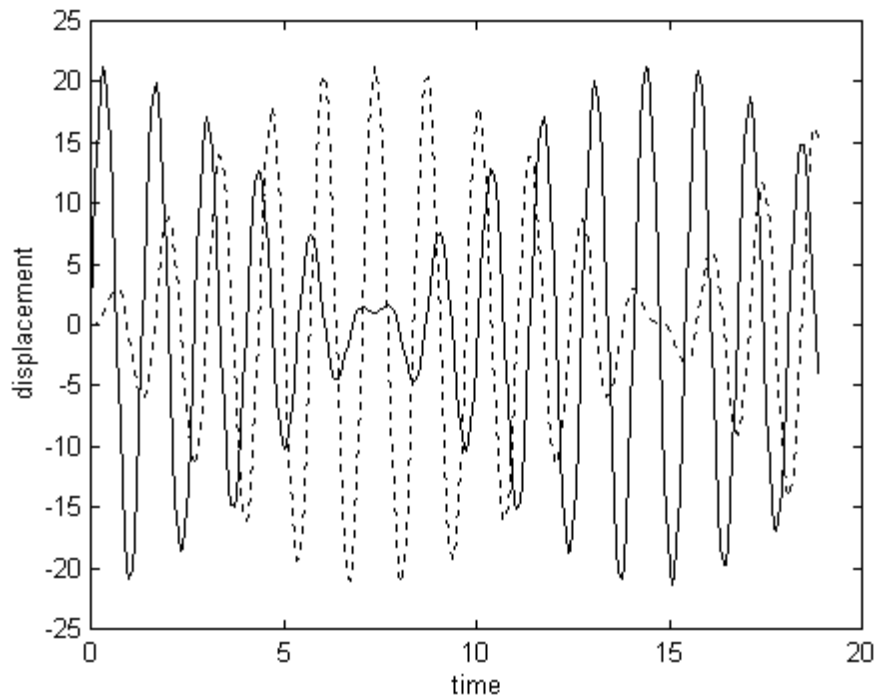

Figure A2: Time evolution of two coupled oscillators.

Pushing mass #1 is analogous to exciting a donor with light. The donor remains excited for some period of time that inversely depends on the interaction strength between the excited donor and neighboring, ground state acceptor. Then the excitation hops to the acceptor, much like the oscillations which hop from one mass to another in the model described above. The donor that was initially excited falls to its ground state and the acceptor onto which the excitation hopped is promoted to its first excited state. This process is generally called energy transfer.