

Massachusetts Institute of Technology
Department of Electrical Engineering and Computer Science

6.002 - Electronic Circuits
Fall 2000

Homework #2
Handout

Issued 9/14/2000 - Due 9/22/2000

Exercise 2.1: Determine the resistance of each network shown below as viewed from its port.

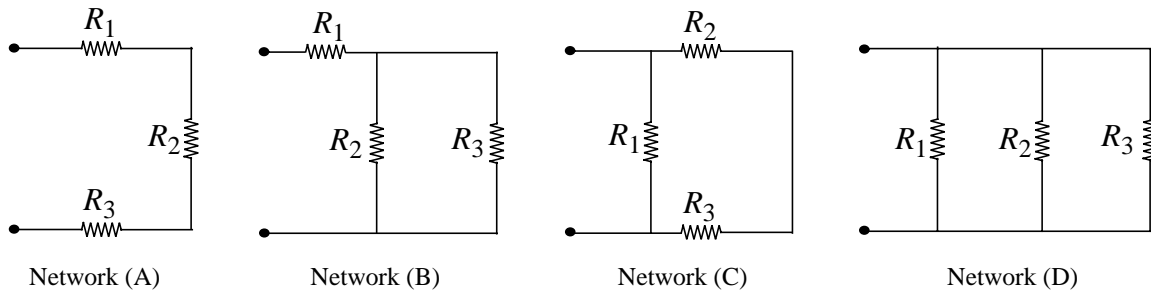

Exercise 2.2: For both networks shown below, find the voltage across each resistor. Hint: make use of the results of Exercise 2.1.

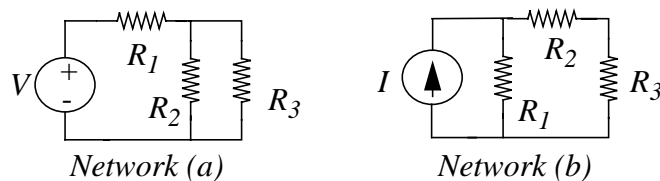

Exercise 2.3: Following the node method, develop a set of simultaneous equations for the network shown below that can be used to solve for the three unknown node voltages in the corresponding network. Express these equations in the form

$$G \begin{bmatrix} e_1 \\ e_2 \\ e_3 \end{bmatrix} = S$$

where G is a 3×3 matrix of conductance terms and S is a 3×1 vector of terms involving the sources. You need not solve the set of equations for the node voltages.

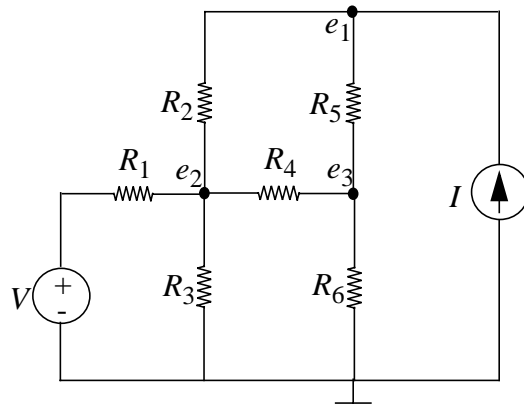

Problem 2.1: Find the Thevenin and Norton equivalents of the following networks, and graph their i - v relations as viewed from their ports.

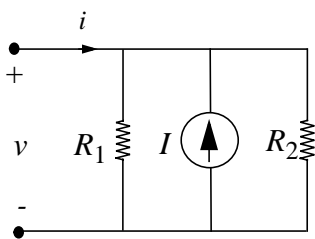

Network (A)

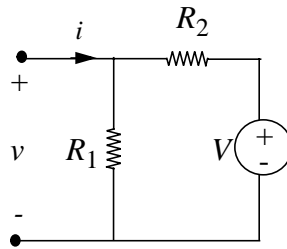

Network (B)

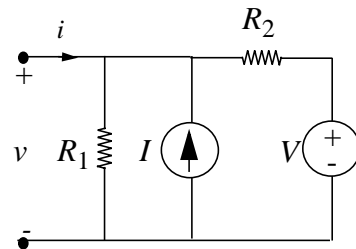

Network (C)

Problem 2.2: Do problem 9 on page 138 of the notes.