

Massachusetts Institute of Technology
Department of Electrical Engineering and Computer Science

6.002 - Electronic Circuits
Fall 2000

Homework #5

Issued 10/5/2000 - Due 10/13/2000

Reading: Sections 8.1 - 8.5

Exercise 5.1: Do Exercise 1 from Chapter 8 of the notes (pages 300-301).

Exercise 5.2: Do Exercise 3 from Chapter 8 of the notes (page 301-302).

Exercise 5.3: Determine the Thevenin equivalent of the following circuit. Note that it contains a dependant source.

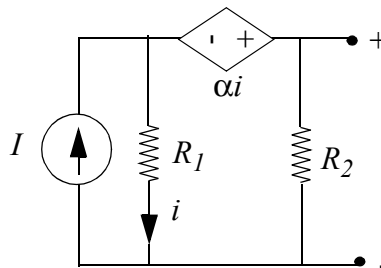

Problem 5.1: This problem studies the two amplifiers shown on the other side of the page. Amplifier A is a single-stage amplifier implemented with a voltage-dependent current source and a pull-up resistor. Assume that the current source parameters G and V_T satisfy $G > 0$ and $V_S > V_T > 0$. Also assume that $RG < \frac{V_S}{V_S - V_T}$. Amplifier B is a two-stage amplifier in which each stage is identical to Amplifier A.

- (A) Determine v_{OUT} as a function of v_{IN} for Amplifier A.
- (B) Sketch and clearly label a graph of the input-output relation found in Part (A).
- (C) Determine v_{OUT} as a function of v_{IN} for Amplifier B.
- (D) Sketch and clearly label a graph of the input-output relation found in Part (C).
- (E) Consider Amplifier A again. Show that the dependent current source sinks power for $v_{OUT} > 0$ and sources power for $v_{OUT} < 0$.

- (F) Dependent current sources are most often implemented with transistors that are passive devices, and hence not capable of sourcing power. In this case, the dependent current source in Amplifier A would saturate so that v_{OUT} actually never goes below 0 V. That is, the current through the dependent current source becomes constant and does not increase with a further increase in v_A once the voltage across the source reaches 0 V. Given this revised behavior for Amplifier A, sketch and clearly label a graph of the input-output behavior of Amplifier B for very large G .

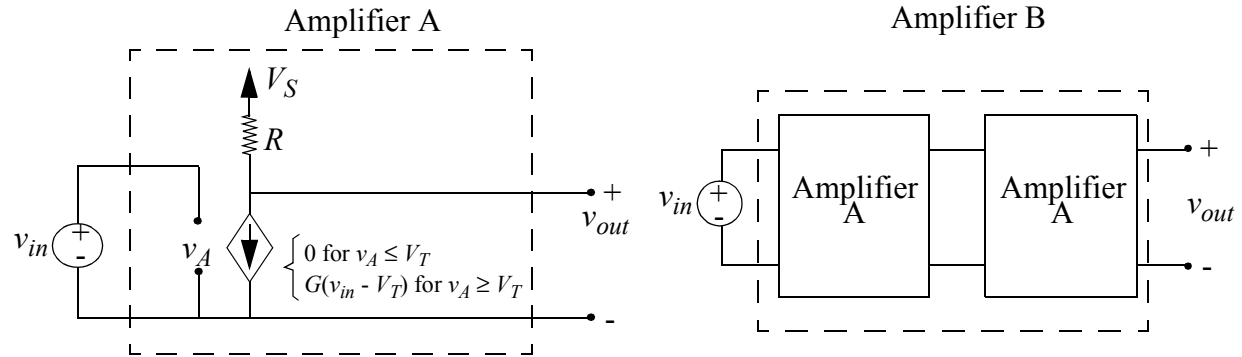

Problem 5.2: Do Problem 5 from Chapter 8 (page 308).

Problem 5.3: Do Problem 9 from Chapter 8 (page 312).