

Massachusetts Institute of Technology
Department of Electrical Engineering and Computer Science

6.002 - Electronic Circuits
Fall 2000

Homework #9
Handout F00-045

Issued 11/2/2000 - Due 11/15/2000

Read Chapter 15.

Exercise 9-1: Using one 3-nF capacitor and two resistors, construct a network that has the following zero-state response to a 1-V step input. Provide a diagram of the network, and specify the values of the two resistors.

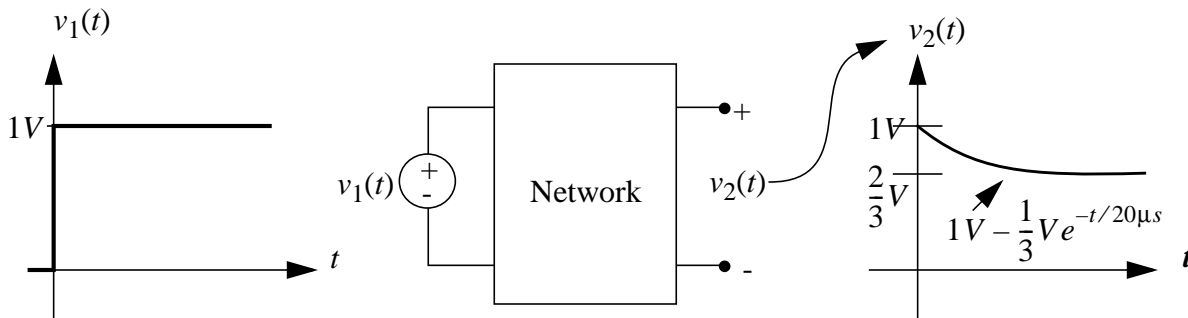

Exercise 9-2: Exercise 4, Chapter 15

Exercise 9-3: Consider a linear time-invariant system. Suppose its ZSR to a unit step applied at $t = 0$ is $A(1 - e^{-t/\tau})$. What would be its ZSR to the input $S + Mt$, applied at $t = 0$, where S and M are constants?

Problem 9.1: Problem 6, Chapter 15

Problem 9.2: In the network shown below, the inductor and capacitor have zero states prior to $t = 0$. At $t = 0$, a step in voltage from 0 to V_0 is applied by the voltage source as shown.

- Find v_C , v_L , i , and $\frac{di}{dt}$ at $t = 0$.
- Argue that $i = 0$ at $t = \infty$ so that $i(t)$ has no constant component.
- Find a second-order differential equation which describes the behavior of $i(t)$ for $t \geq 0$.

- d) Following Part b, the current $i(t)$ takes the form $i(t) = Ie^{-\alpha t} \sin(\omega t + \phi)$. Find I , ω , ϕ , and α . Hint: first find ω and α from the differential equation, and then find I and ϕ from the initial conditions; alternatively, solve this problem by any method you wish.
- e) Suppose that the input is a voltage impulse with area Λ_0 (in Volt-seconds), where $\Lambda_0 = \tau V_0$, V_0 is the amplitude of the voltage step shown below, and τ is a given time constant. Find the response of the network shown below to the impulse. Hint: Before solving this problem directly, consider the relation between step and impulse responses.

Save a copy of your answers to this problem. They will be useful during the pre-lab exercises for Lab #3.

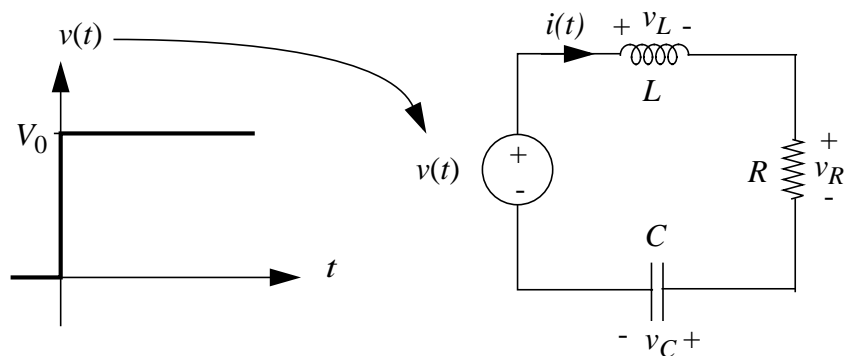

Problem 9.3: James is building a stereo system but needs some help. He needs to take the output of his 8-track tape player and somehow split it into high and low frequencies before sending the signals to the MOSFET amplifiers he built last month, and then to his loudspeakers, so he asks Amanda and Bo for help. A quick web search leads them to <http://www.eatel.net/~ampstech/elecdisc>, where they learn more than they ever wanted to know about car audio and electronic crossovers. Amanda tells him, "All you need is a resistor and an inductor in series. Take the high frequencies off one and the low frequencies off the other." She then leaves to work on her 6.002 problem set. Unfortunately, James forgot to ask which element to connect to his low-frequency woofer and which to connect to his high-frequency tweeter.

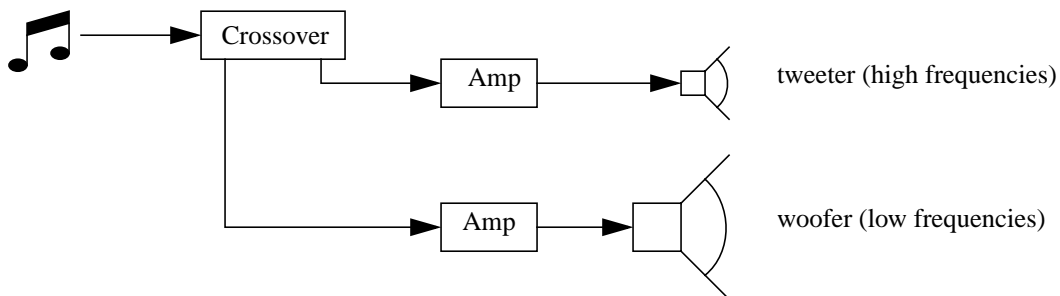

The network suggested by Amanda is shown below left. For the purpose of our analysis, it is driven in steady state by the sinusoidal input voltage $v_i(t) = V_i \cos(\omega t)$, where V_i is real. The outputs of the network are the voltages across the resistor and inductor, $v_{ar}(t) = |V_{ar}| \cos(\omega t + \angle V_{ar})$ and $v_{al}(t) = |V_{al}| \cos(\omega t + \angle V_{al})$, where $|V_{ar}|$ and $|V_{al}|$ denote the amplitude and $\angle V_{ar}$ and $\angle V_{al}$ denote the phase of complex numbers V_{ar} and V_{al} . Find the amplitude and phase, as functions of ω , for both V_{ar} and V_{al} as follows:

- a) Using the Taylor series expansions for e^{jx} , $\cos(x)$, and $\sin(x)$, show that $e^{jx} = \cos(x) + j\sin(x)$. Following this, recognize that $\cos(x) = \text{Re}\{e^{jx}\}$.
- b) Find the magnitude and phase of $A + Bj$. Express $A + Bj$ and $\frac{1}{A + Bj}$ in polar form.
- c) Find differential equations which can be solved for $v_{ar}(t)$ and $v_{al}(t)$.
- d) Following Part a, let $v_i(t) = \text{Re}\{V_i e^{j\omega t}\}$. Also, let $v_{ar}(t) = \text{Re}\{V_{ar} e^{j\omega t}\}$ and $v_{al}(t) = \text{Re}\{V_{al} e^{j\omega t}\}$, where V_{ar} and V_{al} are complex functions of ω . With these substitutions, use the corresponding differential equation to find V_{ar} and V_{al} . Hint: recall that in the differential equations we can drop the $\text{Re}\{ \}$ notation until the end.
- e) Following Parts a and b, find the magnitude and phase for both V_{ar} and V_{al} , as functions of ω and V_i .
- f) Sketch and clearly label the dependence of $\log\left(\frac{V_{ar}}{V_i}\right)$ and $\angle\frac{V_{ar}}{V_i}$, and $\log\left(\frac{V_{al}}{V_i}\right)$ and $\angle\frac{V_{al}}{V_i}$, with respect to $\log\left(\frac{\omega L}{R}\right)$. Identify the low- and high-frequency asymptotes on each sketch.
- g) The breakpoint frequency for a plot is that frequency at which its low- and high- frequency asymptotes cross. Find the breakpoint frequency for the plots in Part f. (For a low-pass filter, its output is nearly constant below this frequency, while above this frequency, its output decreases with increasing frequency. The situation is reversed for the case of the high-pass filter.)
- h) Which terminals should be connected to his high-frequency tweeter and which to his low-frequency woofer? Discuss qualitatively, but physically, how the outputs act as low-pass or high-pass filters.
- i) Meanwhile, Bo suggests the network below right; after a mighty struggle, James obtains the following equations that govern the behavior of $v_{br}(t)$ and $v_{bc}(t)$:

$$\frac{V_{br}}{V_i} = \frac{j\omega RC}{1 + j\omega RC}, \text{ and } \frac{V_{bc}}{V_i} = \frac{1}{1 + j\omega RC}.$$

By comparing these equations with those found in Part d, determine how James would use such a circuit as his crossover. Note: do not do anything complicated to the equations, just draw conclusions from the similarities with your prior answer. Feel free to comment on the location of the breakpoint for Bo's circuit.

