

Massachusetts Institute of Technology  
Department of Electrical Engineering and Computer Science

6.002 – Circuits and Electronics  
Spring 2003

Handout S03-059 - Lab #4: Audio Playback System

**Introduction**

In this lab, you will construct, test and demonstrate the audio playback system that you designed in Homework #11. The lab consists of two parts: pre-lab exercises and in-lab exercises; there are no post-lab exercises. You should complete the pre-lab exercises in your lab notebook before coming to lab. Then, carry out the in-lab exercises on your assigned lab day between May 5 and May 9. After completing the in-lab exercises, have a TA or LA check your work and sign your lab notebook. You may hand in your lab notebook to *your* TA for grading at that time, or any other time before the week of final exams.

During the in-lab exercises, you are welcome to work with a partner. In this case, it is best if one person constructs the clock and digital-to-analog converter, while the other person constructs the low-pass filter and power amplifier. These blocks can be constructed on separate protoboards. Signal and ground connections may then be made between protoboards to complete the construction of the audio playback system. The point of working with a partner is to speed up construction, but not to miss out on testing all four blocks. If you do work with a partner, make sure to participate in testing the two blocks constructed by your partner so that you see how they work.

**Pre-Lab Exercises**

- (4-1) Copy your design for the clock from Problem 1 of Homework #11 into your lab notebook. Label all resistor and capacitor names and values.
- (4-2) Next to your design for the clock, copy the graph from Part (E) of Problem 1 of Homework #11 into your lab notebook. You will use this information to determine whether the clock you construct during In-Lab Exercise 4-2 works correctly.
- (4-3) Copy your design for the digital-to-analog converter from Problem 2 of Homework #11 into your lab notebook. Label all resistor names and values.
- (4-4) Next to your design for the digital-to-analog converter, make a table showing the expected converter output  $v_{\text{DAC}}$  when each of the data-bit input voltages is 5 V and the others are all 0 V. Base the table on the actual resistor values used in your design. Also, note the expected value of the offset voltage  $v_{\text{OFF}}$  required to center the converter. You will use this information to determine whether the converter you construct during In-Lab Exercise 4-4 works correctly.
- (4-5) Copy your design for the low-pass filter from Problem 3 of Homework #11 into your lab notebook. Label all resistor and capacitor names and values.
- (4-6) Next to your design for the low-pass filter, copy the graph from Part (F) of Problem 3

of Homework #11 into your lab notebook. Also, make a table showing the expected magnitude and phase of the filter output  $v_{\text{LPF}}$  given a 2-V peak-to-peak sinusoidal input with a frequency of 4 kHz, 8 kHz and 16 kHz. Base the table on the actual resistor and capacitor values used in your design. You will use this information to determine whether the filter you construct during In-Lab Exercise 4-6 works correctly.

- (4-7) Copy your design for the power amplifier from Problem 4 of Homework #11 into your lab notebook. Label all resistor and capacitor names and values. Include the modification which provides for a variable gain of 1 to 5.
- (4-8) Next to your design for the power amplifier, make a table showing the expected magnitude and phase of the power amplifier output  $v_{\text{OUT}}$  given a 2-V peak-to-peak sinusoidal input with a frequency of 10 Hz, 100 Hz and 1 kHz. Base the table on the actual resistor and capacitor values used in your design. You will use this information to determine whether the amplifier you construct during In-Lab Exercise 4-8 works correctly.

### In-lab Exercises

The in-lab exercises involve constructing and testing the individual functional blocks of the audio playback system, and then demonstrating the operation of the system as a whole. Before you begin to work on the in-lab exercises, you must obtain from the Instrument Desk in the Lab a plug-in board with the counter and memory and a piezo-electric speaker. The 74HC14 CMOS inverter chip needed for constructing the clock can be found in your lab kit. You must return the board and the speaker or headphones after you finish this lab. There are a limited number of parts, and other students will need them.

The in-lab exercises are organized so that you will construct and test one functional block at a time. As each block is found to work properly, you will connect it to those which already work. Consequently, you will alternately construct and test various parts of the audio playback system. *As you develop the system in this manner, it is essential that you turn off the power to the protoboard before you make modifications to your system, or begin any new construction. Also, check your wiring carefully before turning the power back on.* This will avoid damaging the components in the system, and save you considerable debugging time.

Finally, construct the functional blocks as compactly and neatly as possible. In this spirit, you should find it easiest to use the components to wire themselves together, rather than using extra wires. This will save you considerable construction time, as well as considerable debugging time.

- (4-1) To minimize wiring in this lab, the counter and memory have already been assembled on a printed-circuit board. On the back of this board are pins that will plug into the protoboards in the Lab. Plug these pins into the protoboards so that each pin is inserted into a separate protoboard row. Further, locate the board so that there is considerable protoboard space on the side with the memory output data bits. This will make connection to the board easiest. For example, locating the board towards the lower left corner of the protoboard may prove best. The clock can then be constructed above the board, while the digital-to-analog converter, the low-pass filter and the power amplifier can be constructed to the right of the board.

Figure 1 shows the pin assignments for the printed circuit board. The pins for the eight memory output data bits are on the right hand side. The pins for power and ground,

and the clock input to the counter are on the left hand side. You should connect the power pin to the 5-V power supply on the protoboard, and the ground pin to ground on the protoboard. There are also four counter and memory control pins which must be connected to the 5-V power supply and ground as shown in Figure 1.

- (4-2) Following your design from Pre-Lab Exercise 4-1, construct the clock using the 74HC14 inverter chip obtained earlier. Figure 2 shows the pin assignments for the inverter chip. Use any two of the inverters in the chip, and leave the others unconnected. *Do not forget to connect 5 V to  $V_{CC}$  and ground to the inverter chip at the marked terminals!* Do not yet connect the clock output  $v_{CLK}$  to the clock input of the counter. Rather, use one channel of the oscilloscope to observe the oscillator output  $v_{OSC}$ , and trigger the oscilloscope from that channel. Use the other channel to observe  $v_{CAP}$  and the clock output  $v_{CLK}$ . Compare what you observe with the oscilloscope to the graph prepared during Pre-Lab Exercise 4-2 to determine whether or not the clock is functioning properly. In particular, the clock output  $v_{CLK}$  should remain between 0 V and 5 V so as not to damage the counter which it drives.

Note:  $V_H$  and  $V_L$  take on a whole range of values in any logic family, and vary from inverter to inverter. Because the clock was designed assuming values for these voltages, it is possible that it does not oscillate at 8 kHz. Check that it is operating at the proper frequency. If not, adjust  $C$  and  $R$ . You may find it easiest to replace  $R$  with a 10 k $\Omega$  potentiometer connected as a variable resistor.

- (4-3) Provided that the clock functions properly, and most importantly that the clock output  $v_{CLK}$  remains within the range of 0 V to 5 V, connect the clock output to the clock input of the counter. With the oscilloscope, verify that the eight data bits from the memory output are changing in time.
- (4-4) Following your design from Pre-Lab Exercise 4-3, construct the digital-to-analog converter using a 741 op-amp. Figure 3 shows the pin assignments for the 741 op-amp. Do not neglect to connect  $\pm 15$  V to the op amp! Do not yet connect the converter data-bit inputs to the data-bit outputs from the memory. Rather, adjust the offset voltage  $v_{OFF}$  to 0 V,

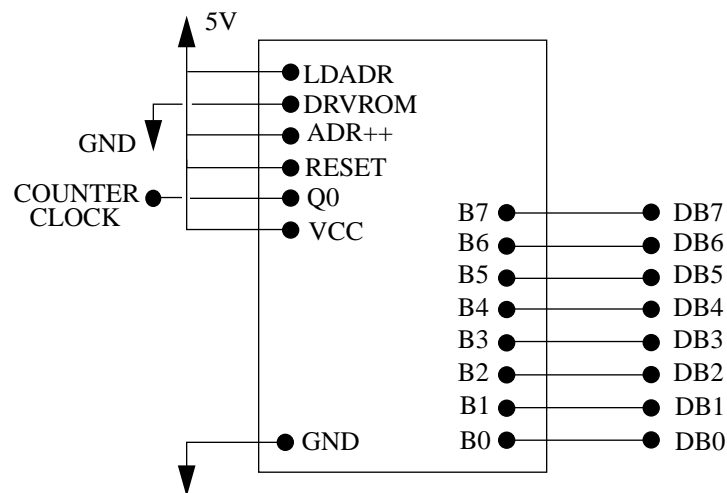

Figure 1: pin assignments for the printed circuit board that contains the counter and memory.

and connect each input individually to the 5-V power supply while leaving the other inputs grounded. Then, measure  $v_{DAC}$  with the multimeter, and compare the measurements to the data in the table prepared during Pre-Lab Exercise 4-4 to determine whether or not the converter is functioning properly.

**Note:** A common mistake here is connecting the inputs backwards to the R-2R ladder. If the output waveform can be described best as a high frequency noisy square wave, rather than as an audio signal, check that you have the data output bits on the ROM board connected in the correct order.

- (4-5) Connect the eight data-bit inputs of the digital-to-analog converter to their corresponding data-bit outputs from the memory; refer to Figure 1 for the memory pin assignments. With the oscilloscope, observe the converter output  $v_{DAC}$ . You should see an audio signal reconstructed in a piecewise constant manner. Adjust the offset voltage  $v_{OFF}$  so that the audio signal is centered around 0 V.

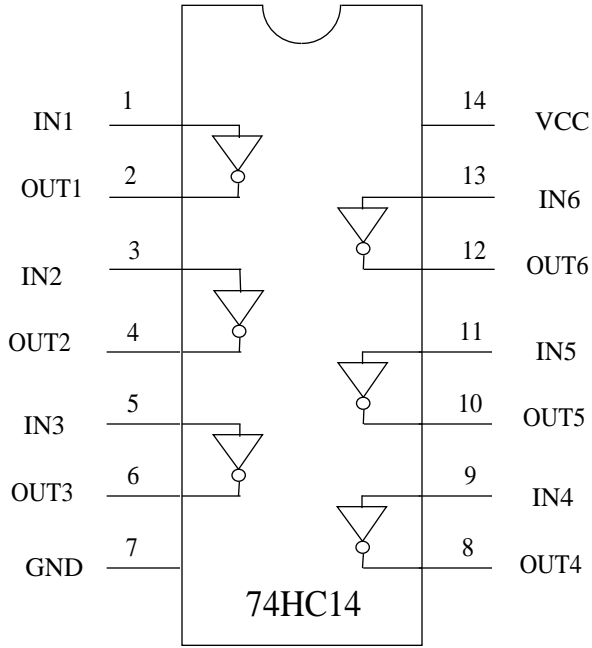

Figure 2: pin assignments for the 74HC14 inverter chip.

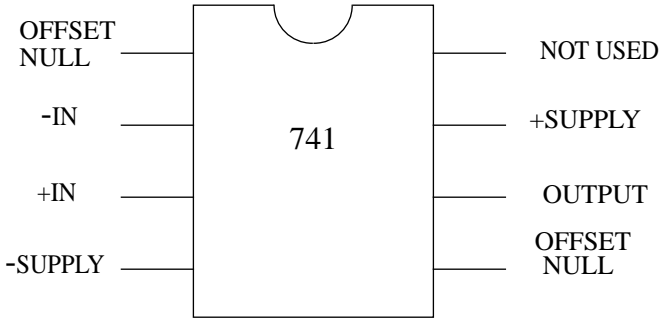

Figure 3: pin assignments for the 741 op-amp.

- (4-6) Following your design from Pre-Lab Exercise 4-5, construct the low-pass filter using a 741 op-amp. Set the function generator to produce an unbiased 1-kHz sinusoid with a 2-V peak-to-peak amplitude and connect it to the input of the filter. With one channel of the oscilloscope, observe the input to the filter, and trigger the oscilloscope from that channel. With the other channel, observe the filter output  $v_{\text{LPF}}$ . Vary the frequency of its input voltage and compare the frequency response of the filter to that predicted by the graph and table prepared during Pre-Lab Exercise 4-6 to determine whether or not the filter is functioning properly.
- (4-7) Connect the output from the digital-to-analog converter to the input of the low-pass filter. Using the oscilloscope, compare the output from the converter to the output from the filter. While the two outputs should look similar, the output from the filter should look considerably smoother upon detailed inspection.

At this point, the peaks of the audio signal should be clearly observable with the oscilloscope at the low-pass filter output  $v_{\text{LPF}}$ . If necessary, adjust  $R_2$  in the digital-to-analog converter so that the peak-to-peak amplitude of the filter output,  $v_{\text{LPF}}$ , is approximately 2.5 V. This adjustment may be necessary if the audio signal was recorded with an insufficient gain. Also, adjust the offset voltage  $v_{\text{OFF}}$  in the converter again if the low-pass filter output  $v_{\text{LPF}}$  does not appear to be centered around 0 V.

- (4-8) Since the publication of Homework #11, our choice of audio transducer has changed. Instead of using an ordinary speaker or pair of headphones, we have decided to use a piezoelectric speaker as the transducer. This is primarily because a piezoelectric speaker is more robust, and it is more easily driven with a 741 op-amp. You can obtain a piezoelectric speaker at the Instrument Desk in the Lab, Room 38-501.

Following your design from Pre-Lab Exercise 4-7, construct the power amplifier using a 741 op-amp, but do not yet connect it to the speaker. Set the function generator to produce an unbiased 1-kHz sinusoid with a 2-V peak-to-peak amplitude and connect it to the input of the power amplifier. With one channel of the oscilloscope, observe the input to the amplifier, and trigger the oscilloscope from that channel. With the other channel, observe the amplifier output  $v_{\text{OUT}}$ . With the gain of the power amplifier set to 5, vary the frequency of its input voltage and compare the frequency response of the amplifier to that predicted by the table prepared during Pre-Lab Exercise 4-8 to determine whether or not the amplifier is functioning properly. Also, vary the gain of the power amplifier and verify that it ranges from 1 to 5, at least for frequencies between 1 kHz and 10 kHz.

- (4-9) Next, connect the power amplifier to the piezoelectric speaker according to your design from Pre-Lab Exercise 4-7. Set the function generator to produce an unbiased 1-kHz sinusoid with a 2-V peak-to-peak amplitude and connect it to the input of the amplifier. You should now hear a single-harmonic tone. Sweep the frequency of the signal generator over the range of 10 Hz to 10 kHz and vary the gain of the power amplifier. As you do this, use the oscilloscope to again demonstrate that the power amplifier is working properly.
- (4-10) Complete the audio playback system by connecting the output of the low-pass filter directly to the input of the power amplifier, and set the gain of the power amplifier to 1. You should now hear the audio signal recorded in the memory as it is played back through the speaker or headphones. It is possible that the original audio signal was digitized and recorded in the memory at lower than full amplitude. In this case, the peak-to-peak voltage across

the piezoelectric speaker needs to be increased. To compensate for this, increase the gain of the power amplifier. You can do this by changing the series feedback resistor  $R_2$  in the power amplifier.

The piezoelectric speaker has an internal resonance at about 4 kHz. When this resonance is excited the speaker sounds as if it is rattling. In order to damp this resonance and produce a better sounding output, you might try covering the output port of the speaker slightly, or stuffing a very small amount of soft cotton into the speaker port.

- (4-11)** As a final in-lab exercise, experiment with the audio playback system. For example, remove the low-pass filter and see how your perception of the audio signal changes. Also, disconnect one or more of the least significant memory data bits from the digital-to-analog converter and see how your perception of the audio signal changes. Try this with and without the low-pass filter. How many data bits are necessary to make the audio signal intelligible?