

Massachusetts Institute of Technology
Department of Electrical Engineering and Computer Science

6.002 – Electronic Circuits
Fall 2000

Quiz 2

- Please write your name in the space provided below, and circle the name of your recitation instructor and the time of your recitation.
- Please verify that there are 13 pages in your exam.
- To the extent possible, do all of your work on the pages contained within this exam. In particular, try to do your work for each question within the boundaries of the question, or on the back side of the page preceding the question.
- You may use one double-sided page of notes while taking this exam.
- Good luck!

Problem	Score
1	
2	
3	
4	
5	
Total	

Name: _____

Instructor: Senturia Wilson Parker Hagelstein Sussman
Time: 9 10 10 11 11 12 12 2 3

Problem 1 – 15 Points

Consider the voltage divider shown below. Assume that the MOSFET operates in its saturation region, such that

$$i_{DS} = \frac{K}{2}(v_{GS} - V_T)^2$$

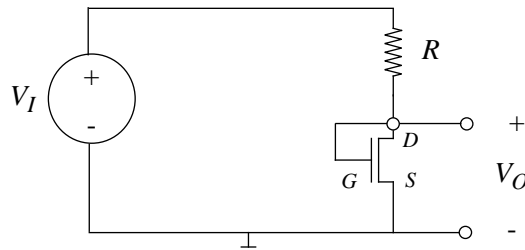

(A) Given that $V_I = 5V$, $K = 2mA/V^2$, and $V_T = 1V$, find R such that $V_O = \frac{1}{2}V_I$.

(B) Assume that $V_I = 5V$, $K = 2mA/V^2$, and $V_T = 1V$. Given that R is selected such that $V_O = \frac{1}{2}V_I$, show that the MOSFET operates in its saturation region.

Problem 2 – 10 Points

Develop the small signal model for a two-terminal device formed by a MOSFET with its gate tied to its drain (see below), operating under the saturation discipline. Under the saturation discipline, the MOSFET is characterized by the equation

$$i_{DS} = \frac{K}{2}(v_{GS} - V_T)^2$$

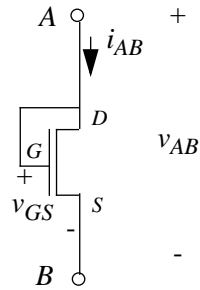

Problem 3 – 25 Points

A three-terminal device called the Frammis, its large signal model, and an amplifier based on the Frammis are shown below.

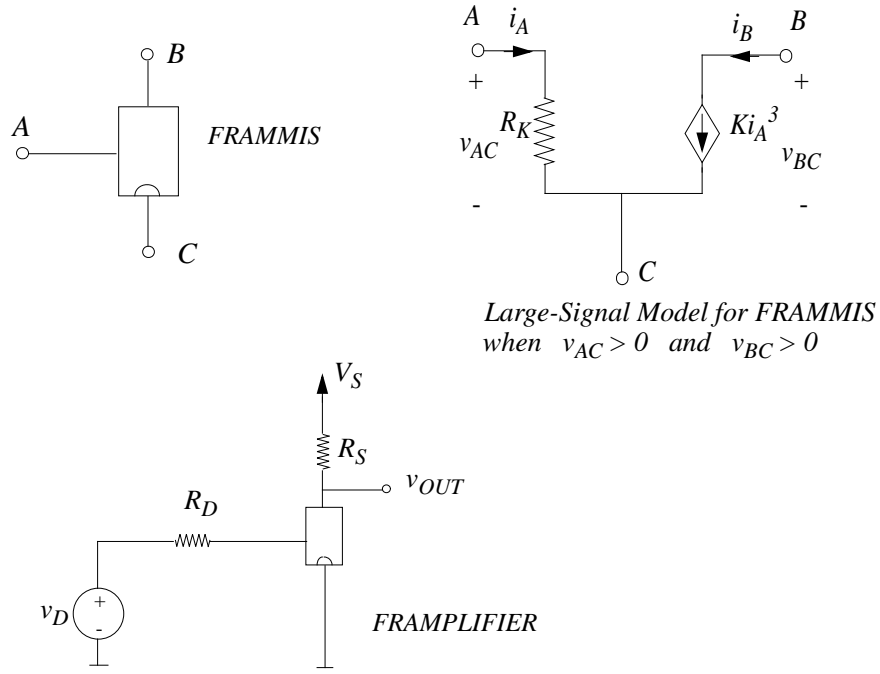

(A) Draw the equivalent large-signal circuit for the Framplifier.

(B) Determine v_{OUT} as a function of v_D .

(C) Assume that $i_A = I_A + i_a$, where i_a is an incremental signal, and I_A is an operating point current. For $I_A \geq 0$, which of the five models shown below represents a valid small signal model for the Frammis device. (Circle your choice).

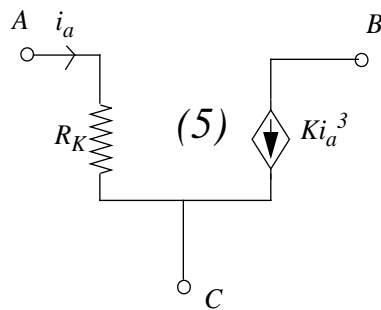
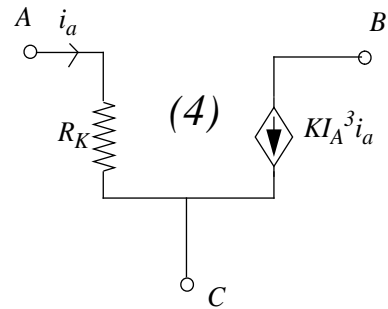
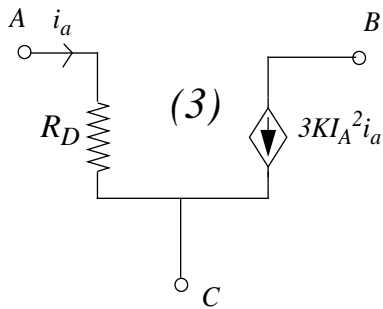
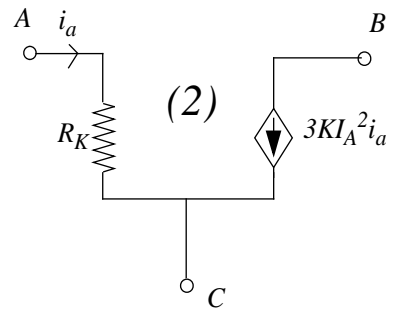
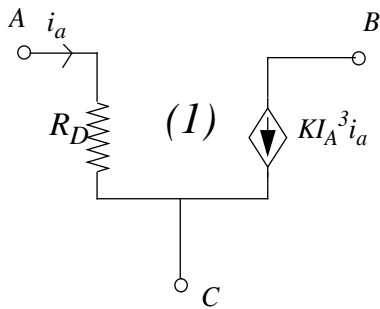

(D) Next, assume that $v_D = V_D + v_d$ and $v_{OUT} = V_{OUT} + v_{out}$, where v_d and v_{out} are incremental signals, and V_D and V_{OUT} are the operating point voltages. Assume that V_D and V_{OUT} are known. Find the small signal gain A given by

$$A = \frac{v_{out}}{v_d}$$

Problem 4 – 25 Points

Consider the circuit comprising a MOSFET and a capacitor of value $C = 0.1\mu F$ shown below. Under the saturation discipline, the MOSFET is characterized by the equation

$$i_{DS} = \frac{K}{2}(v_{GS} - V_T)^2$$

where $K = 2mA/V^2$ and $V_T = 1V$.

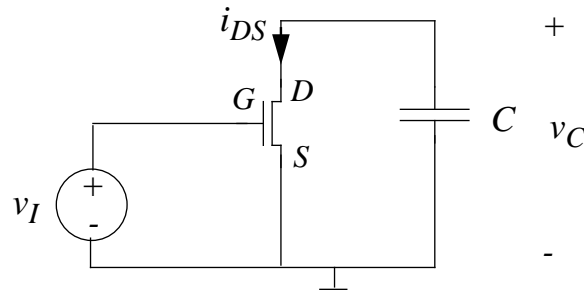

(A) Write the constraint(s) on v_C and v_I such that the saturation discipline is satisfied.

(B) Develop a differential equation relating v_C and v_I when the MOSFET operates in its saturation region.

(C) Plot v_C as a function of time t for $0 \leq t \leq 10\mu S$ given the input v_I as shown below. Assume that $v_C(0) = 20$ volts. Clearly mark the values of v_C for $t = 0$, $t = 1\mu S$ and $t = 10\mu S$.

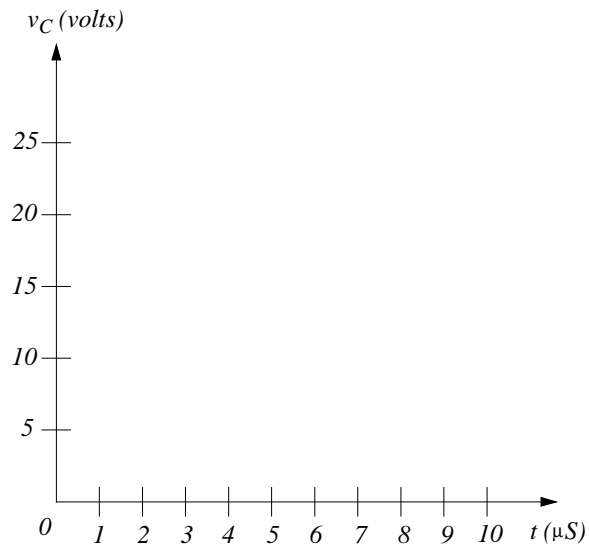
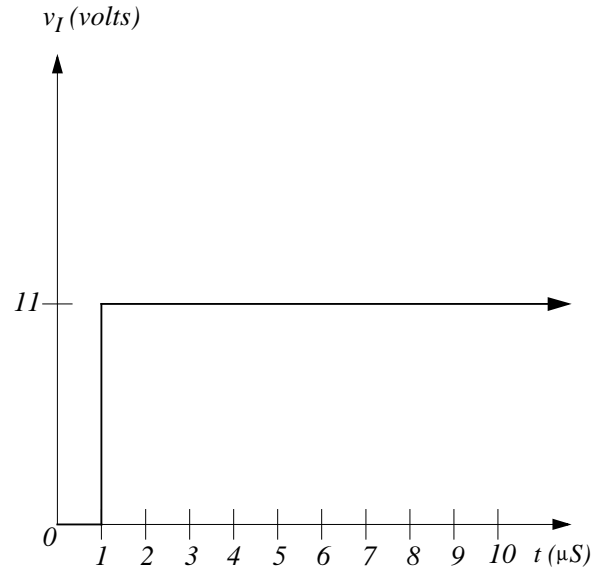

Problem 5 – 25 Points

(A) Professor Will Spark brings to lecture a $100 \mu\text{F}$ capacitor that is charged to 1000 volts. During the lecture he discharges the capacitor with a short, which results in a spark and an audible crack, thus demonstrating that it contains considerable energy. He then recharges the capacitor to 1000 volts and connects it to a $100\text{K}\Omega$ resistor by a switch as illustrated in Figure A. He offers to pass the capacitor to a student in the front row in order to demonstrate that it is safe to touch. How long should he wait to ensure that the capacitor has less than 50 volts across its terminals before passing it on? (Don't worry about simplifying your answer if you do not have a calculator).

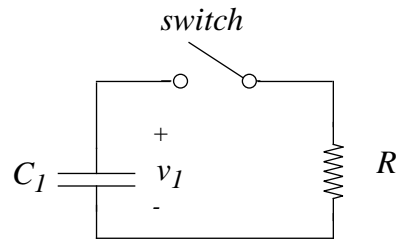

Figure A

(B) A student in the class suggests that to discharge the capacitor faster, he should discharge it through the resistor into a second capacitor C_2 that is initially uncharged. This is illustrated in Figure B. Write a differential equation that can be solved for the current i after the switch is closed in the circuit in Figure B.

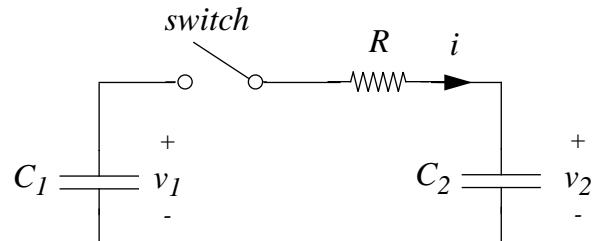

Figure B

(C) If C_2 has half the capacitance of C_1 , what is the characteristic time constant for the circuit in Figure B after the switch is closed?

(D) Assuming that C_1 is initially charged to 1000 volts and that C_2 is initially uncharged, what is the initial value of the current i at the instant the switch is closed?

(E) You will now determine whether the student's idea illustrated in Figure B to discharge the capacitor faster was a good one. Accordingly, given his 50 volt maximum safety criteria, show that Professor Spark can never pass the capacitor C_1 around, or determine the length of time that Professor Spark must wait after the switch is closed before passing capacitor C_1 to the students to handle. Assume as in Part (C), C_2 has half the capacitance of C_1 , and as in Part (D), C_2 is initially uncharged and C_1 is initially charged to 1000 volts.