

# Real Time Wireless ECG Monitoring System

Guilherme K. Kolotelo

Rogers G. Reichert

# Features

- Remote monitoring of patient's heartbeat
- Low heart rate warnings
- Increased mobility by eliminating wired connections

# Modular Design

- 7 Modules
  - Modulator, demodulator
  - Heartbeat detector
  - Low heart rate detector
  - Emergency signal
  - Sound amplifier
  - ECG capture board

# Modulator and Demodulator

- AM transmission
  - Long distance communication
  - Less power consumption
  - Cheaper
- Carrier frequency: 455 kHz
  - Synthesization of carrier wave by separate circuitry

# Carrier Wave Synthesization

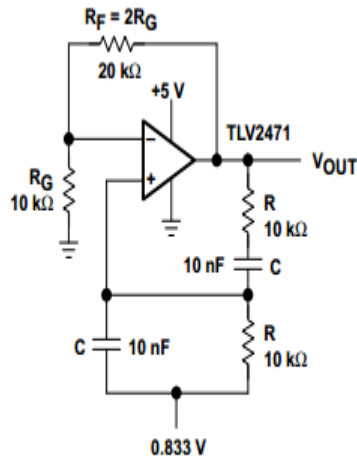

Wien-Bridge Oscillator

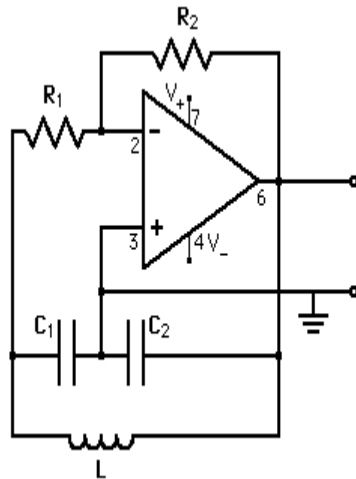

Colpitts Oscillator

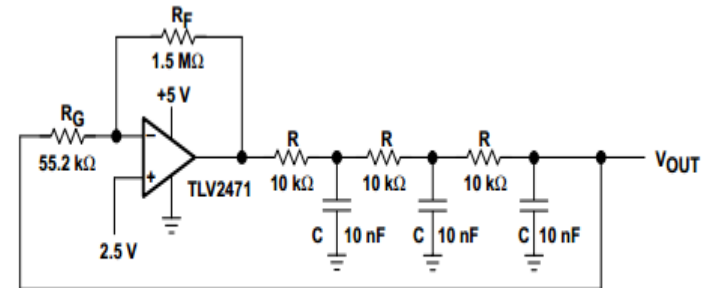

Phase-Shift Oscillator

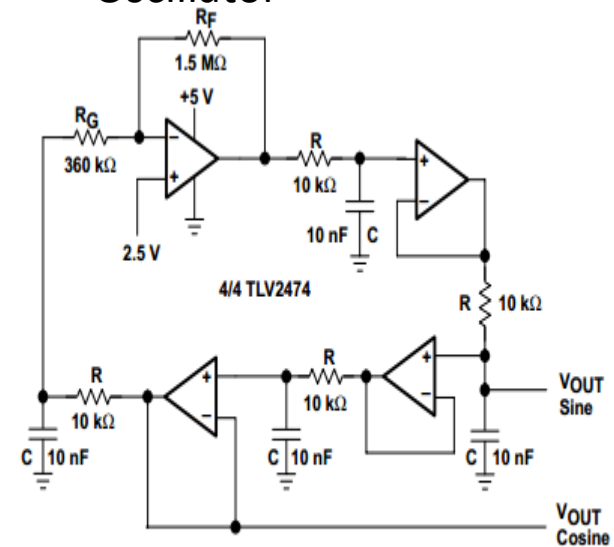

Bubba Oscillator

# Wien-Bridge Oscillator

- Few components
- Good frequency stability
- Designed values translate well into reality
- No inductors

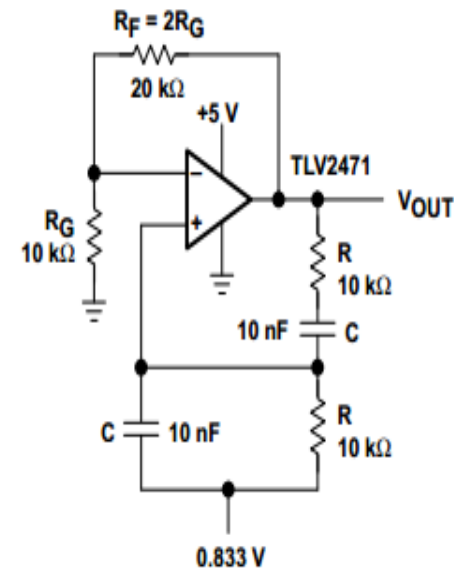

Wien-Bridge  
Oscillator

# Heartbeat detector

- R peak detection
- Translates heartbeats into pulses
- Outputs signal to modulator

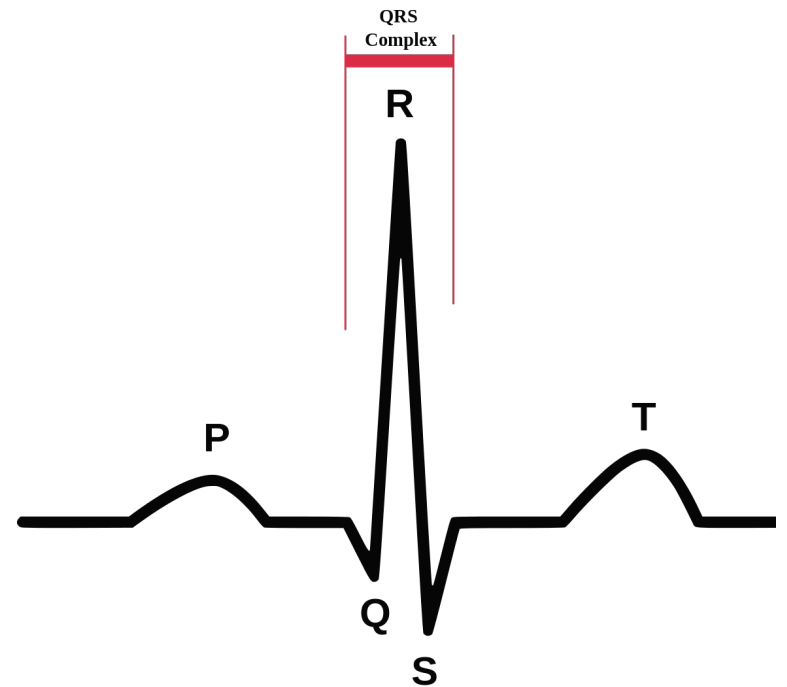

# Low heart rate detection

- Warns user of low heart rate (adjustable)
- Outputs continuous warning tone to audio amplifier

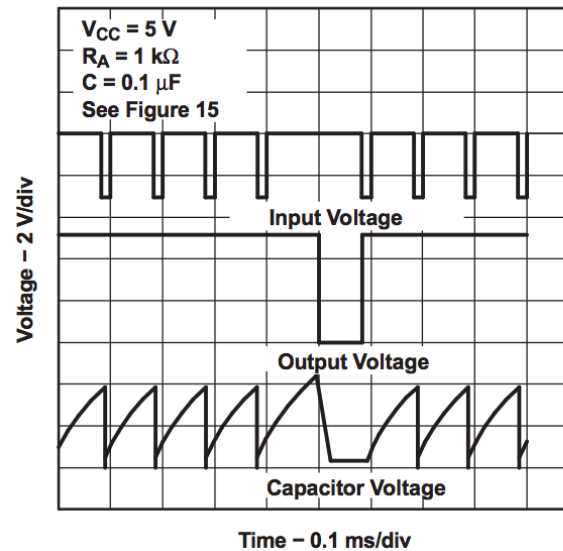
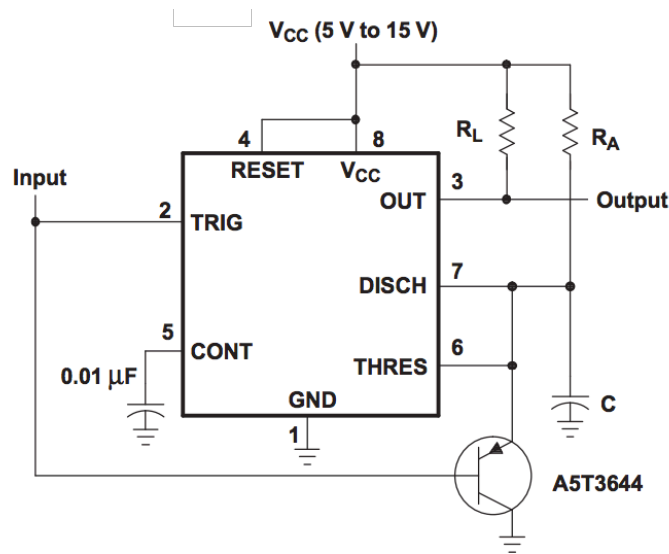



# Sound Amplifier

- Amplifies heartbeat sound and emergency signal to speaker
- Class B amplifier

# ECG capture

- Developed on Lab 5

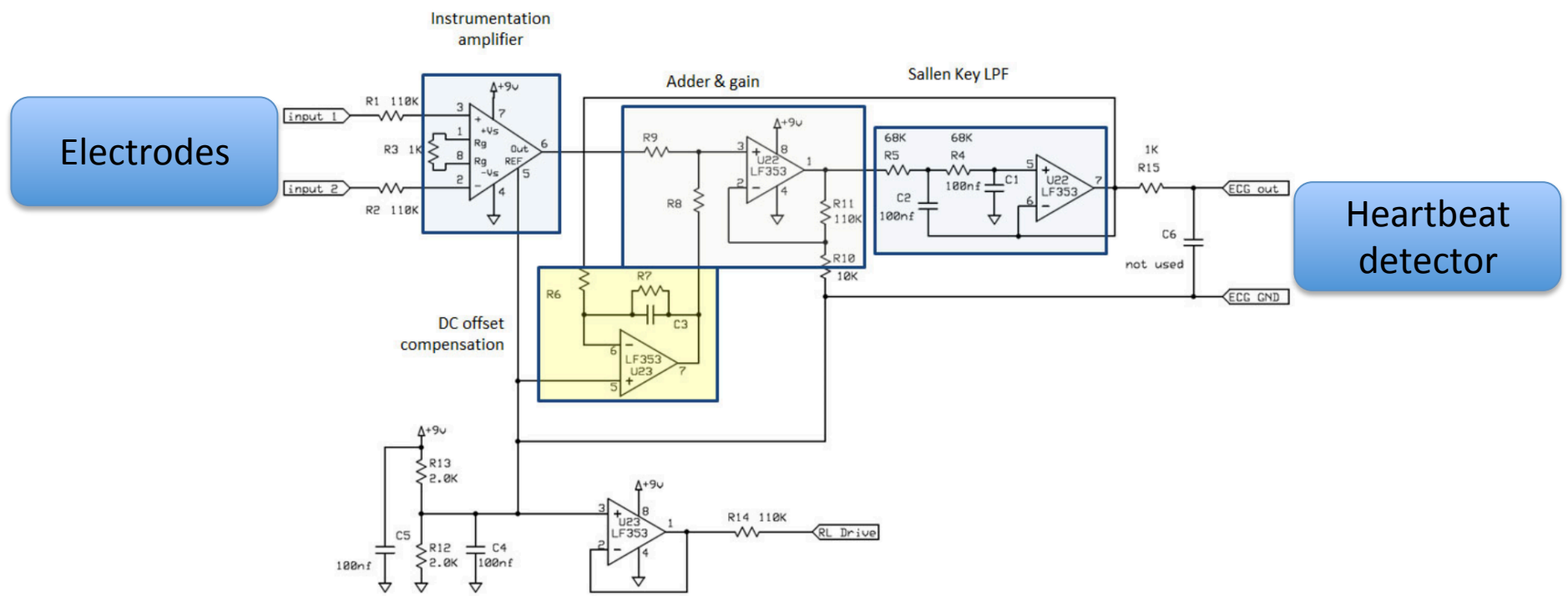

# Block diagram

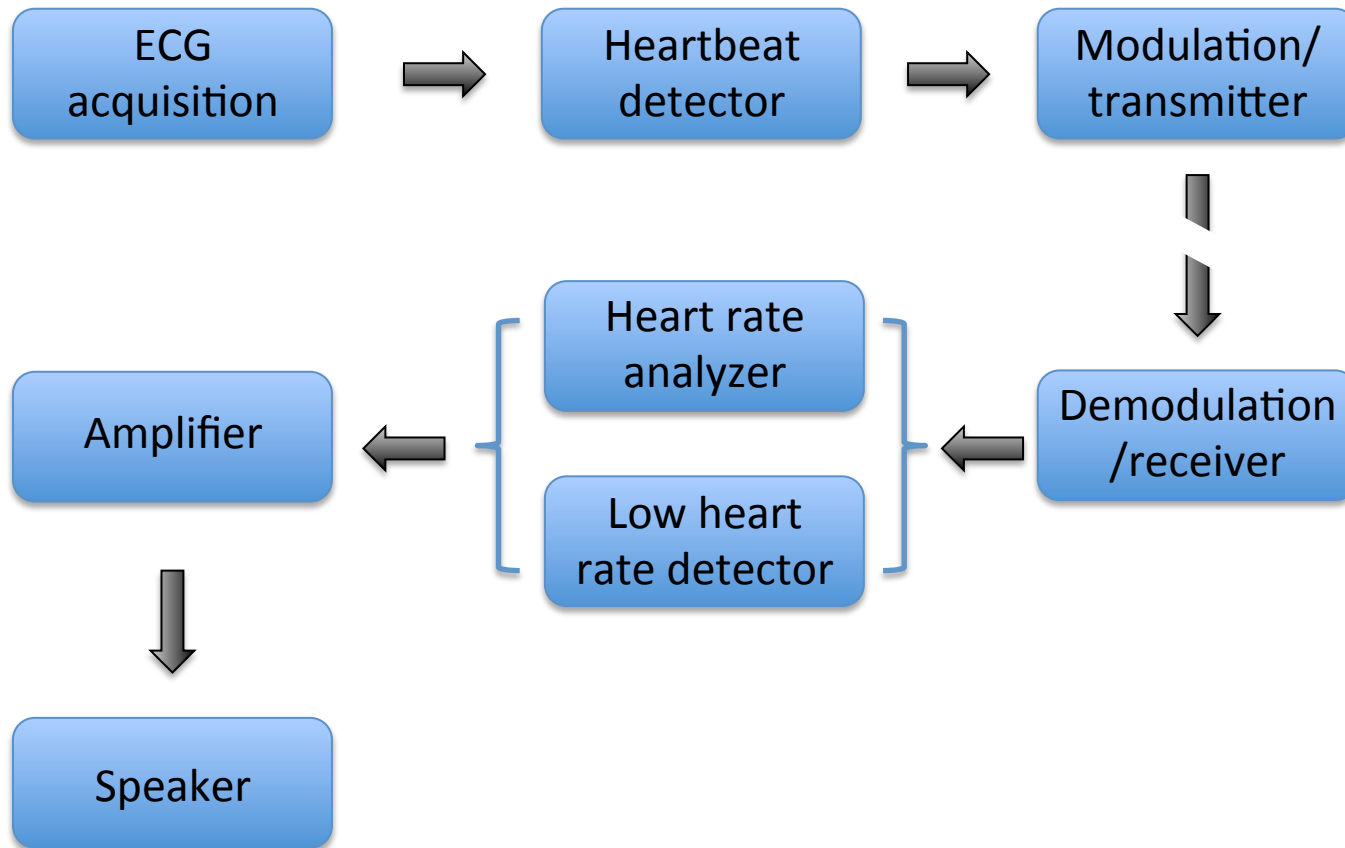

# Schedule

- 1<sup>st</sup> week: designing of modules and circuitry
- 2<sup>nd</sup> week: building of modules and preliminary tests
- 3<sup>rd</sup> week: testing and fixing problems
- 4<sup>th</sup> week: writing of report