

Programmable Audio Visualizer

Dany Qumsiyeh
Mike Spindel

Goals

1. Visualize audio.
2. ???
3. Profit!

Goals

1. Visualize audio.
2. Make it Programmable!
3. Profit!

High Level Architecture

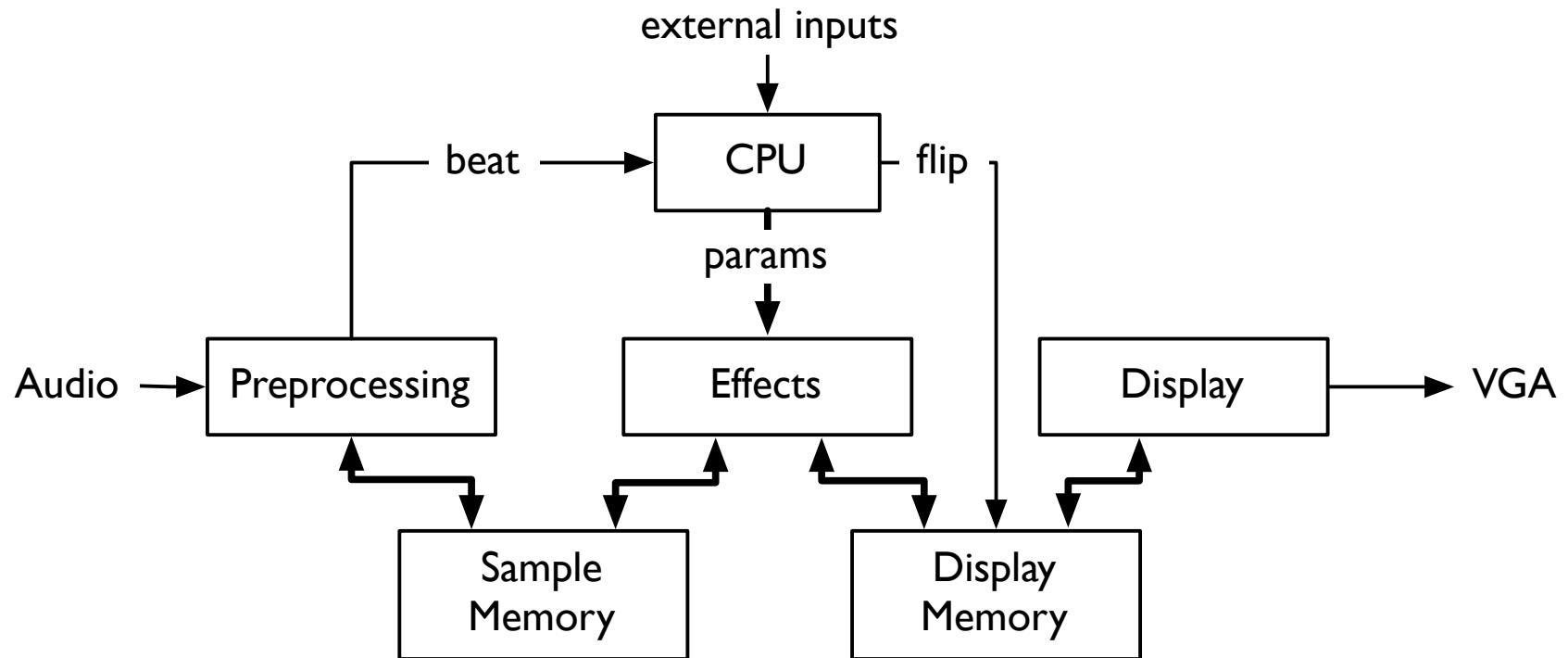

Audio Preprocessor

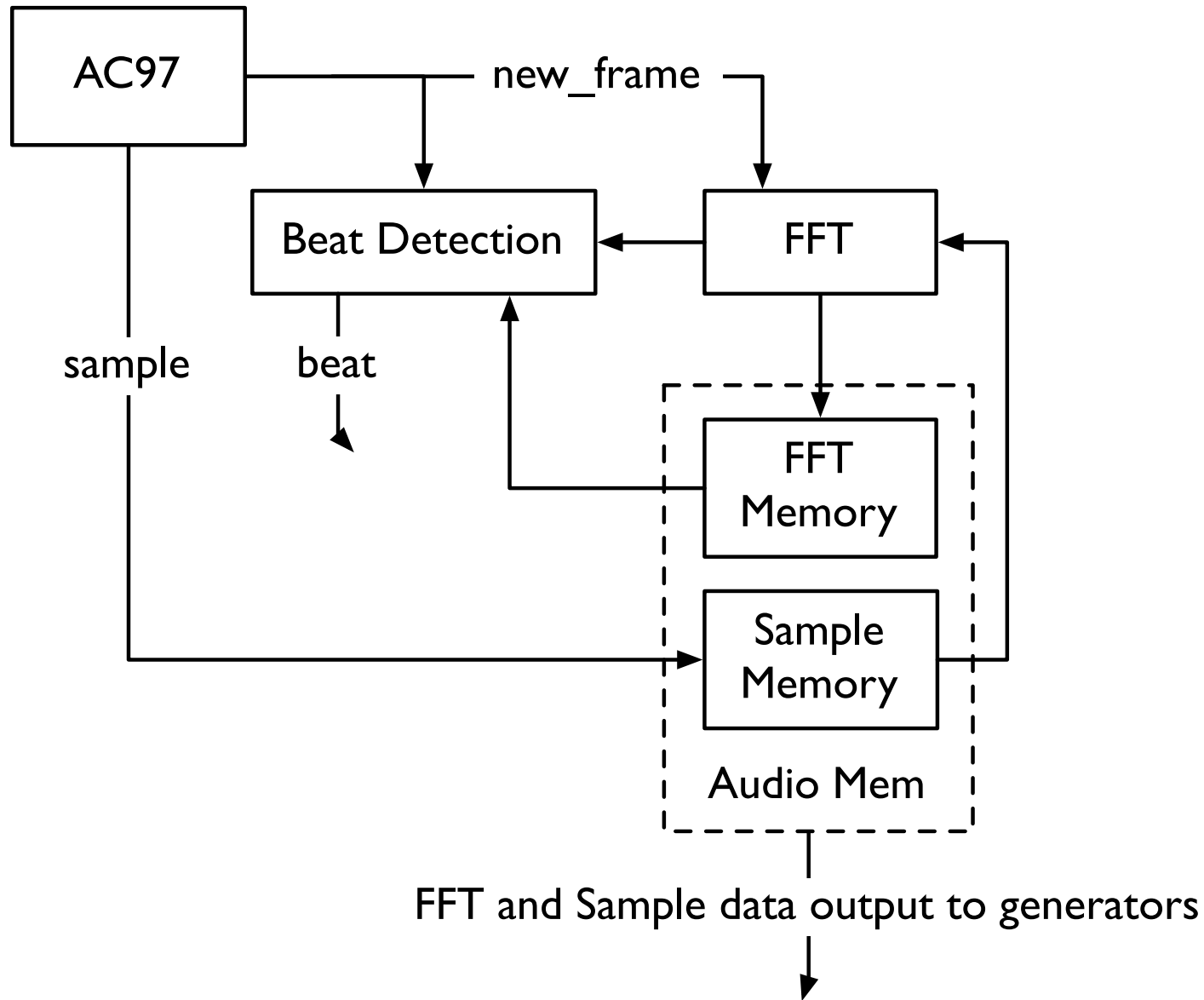

CPU

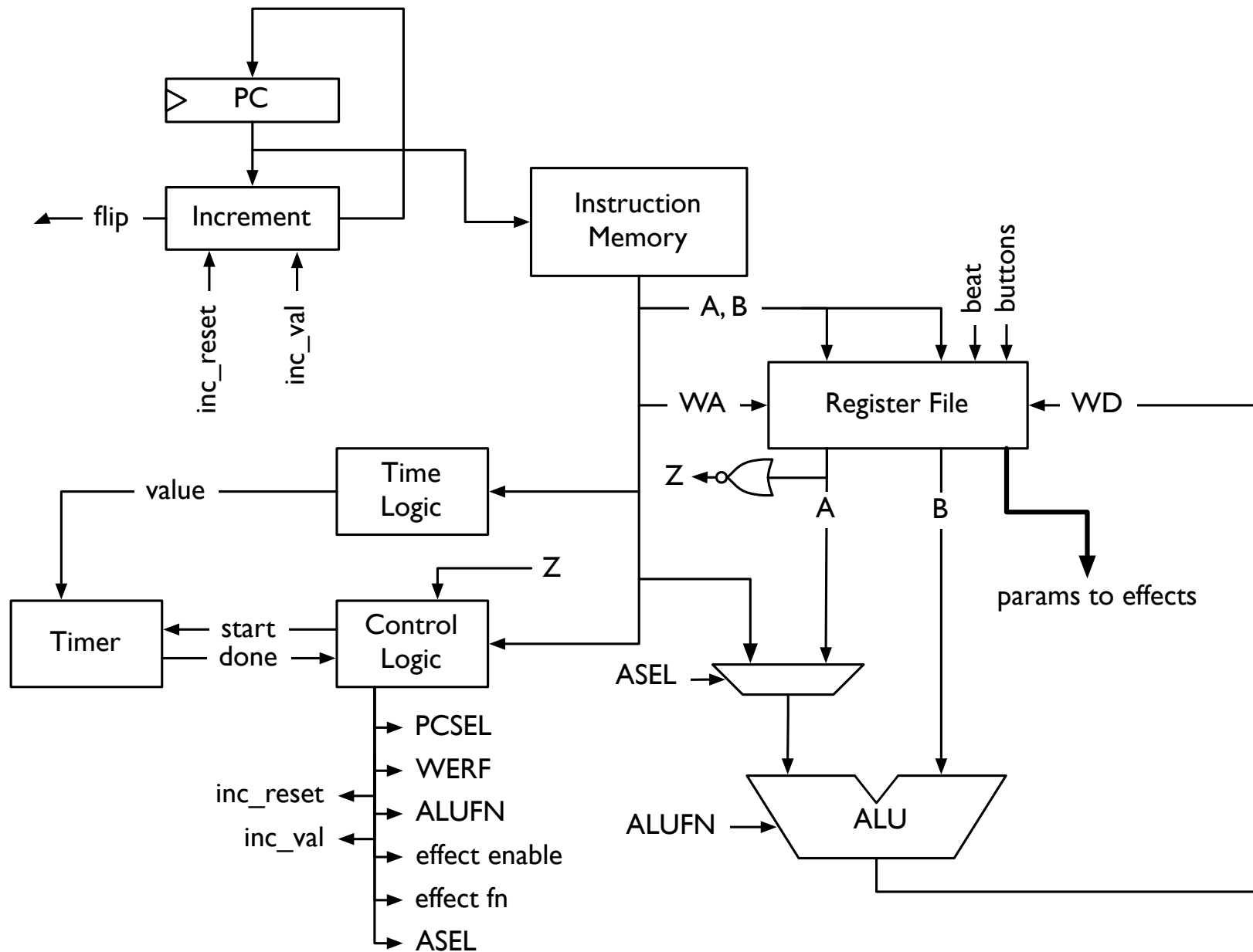

Programming

```
//initialize r1 on reset button
SKIPIF(rBUTTON0,1) //if rBUTTON0==0, skip 1 instruction
CMOVE(r1,0) //set r1 to 0

CMOVE(rDPARAM0,2)
MOVE(rDPARAM1,r1)
... //configure distortion registers

CMOVE(rGPARAM0,1)
MOVE(rGPARAM1,r1)
... //configure generators

GENERATE //run distortion/generators on buffer

... //reconfigure distortion/generators
GENERATE

CMOVE(rC00,-1)
CMOVE(rC01,1)
...
CMOVE(rC22,-1) //specify 2D convolution (3x3)

CONVOLVE //run convolution on buffer

ADDC(r1,1,r1) //vary parameters
```

Effects

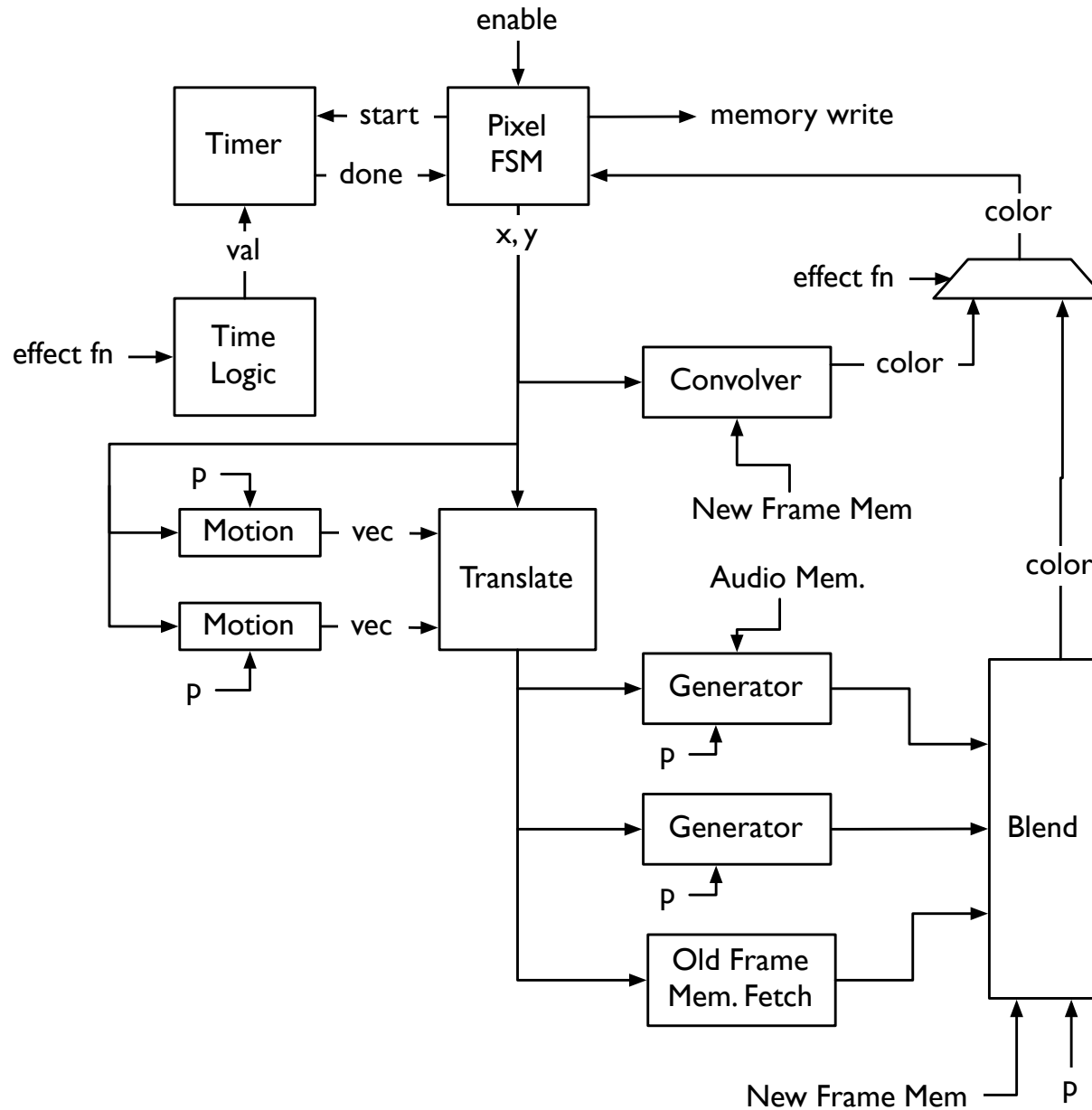

Display

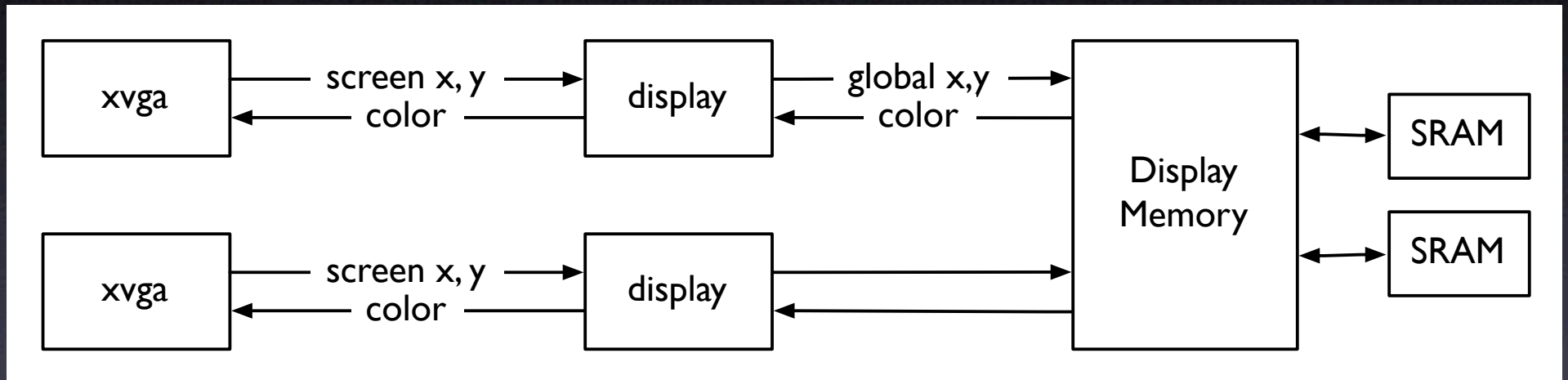

Timeline

Mike Spindel	Dany Qumsiyeh	Date
AC97 → Sample Mem, Pixel FSM	VGA, simple Display, SRAM	11/21
Generator, Blending	Display Memory, CPU substitute	11/28
Translate, Convolve	Full CPU	12/05
FFT, Beat Detection	Display scaling, motion/generators	12/12