

# Voice Over IP

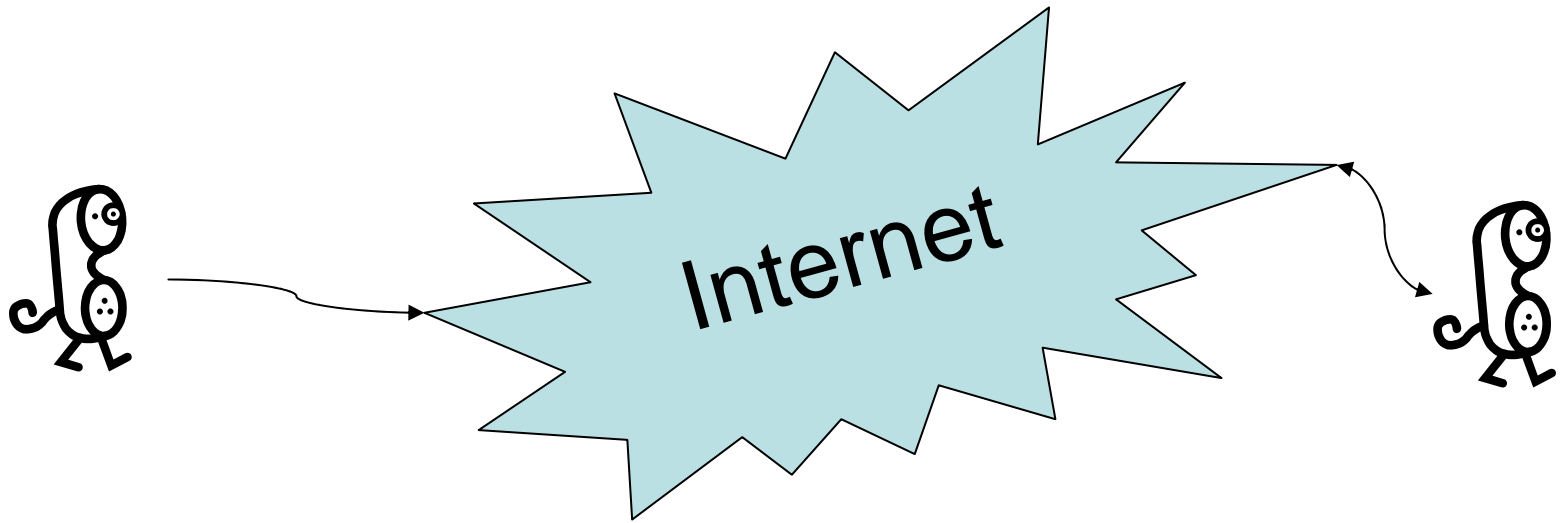

Brian Schmidt

Matt Welsh

# Goals

- Transmit bi-directional voice over the internet
- Implement Internet Protocol packet handling
- Interface with Ethernet controller

# Block Diagram

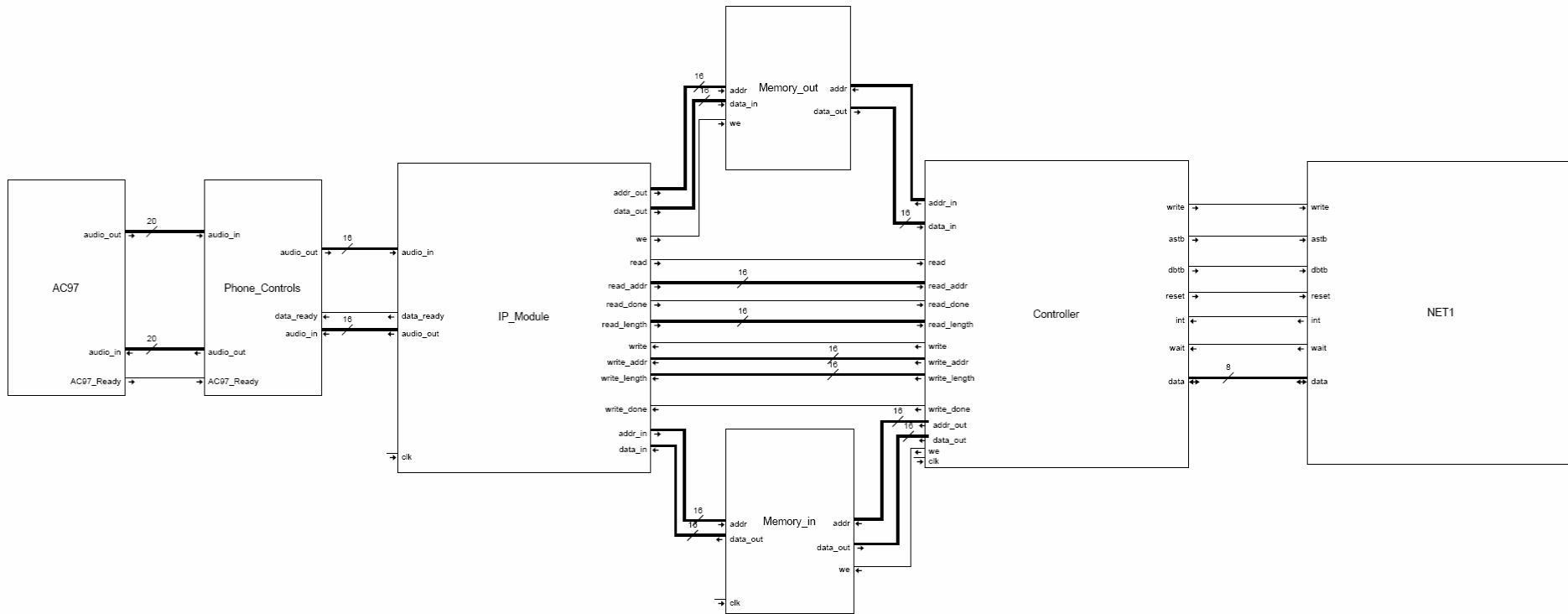

# Controller

- Interface to NET1 Ethernet controller and Ubicom IP2022 Chip
- Communicates with IP handler through FIFO memories
- Testing: Simulation testing for memory modules and Computer program to test data transfers.

# Controller

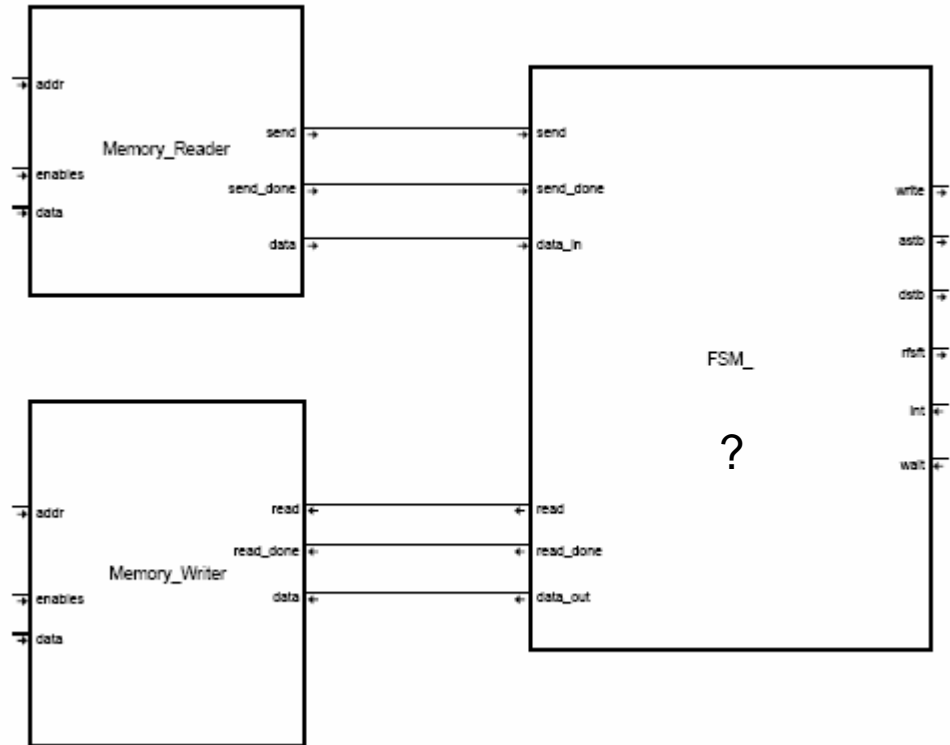

# IP Handler

- Encodes packets using data from AC97
- Decodes packets from Controller to send to AC97
- De-fragments fragmented packets
- May be tested by interfacing with computer

# IP Handler Decoder

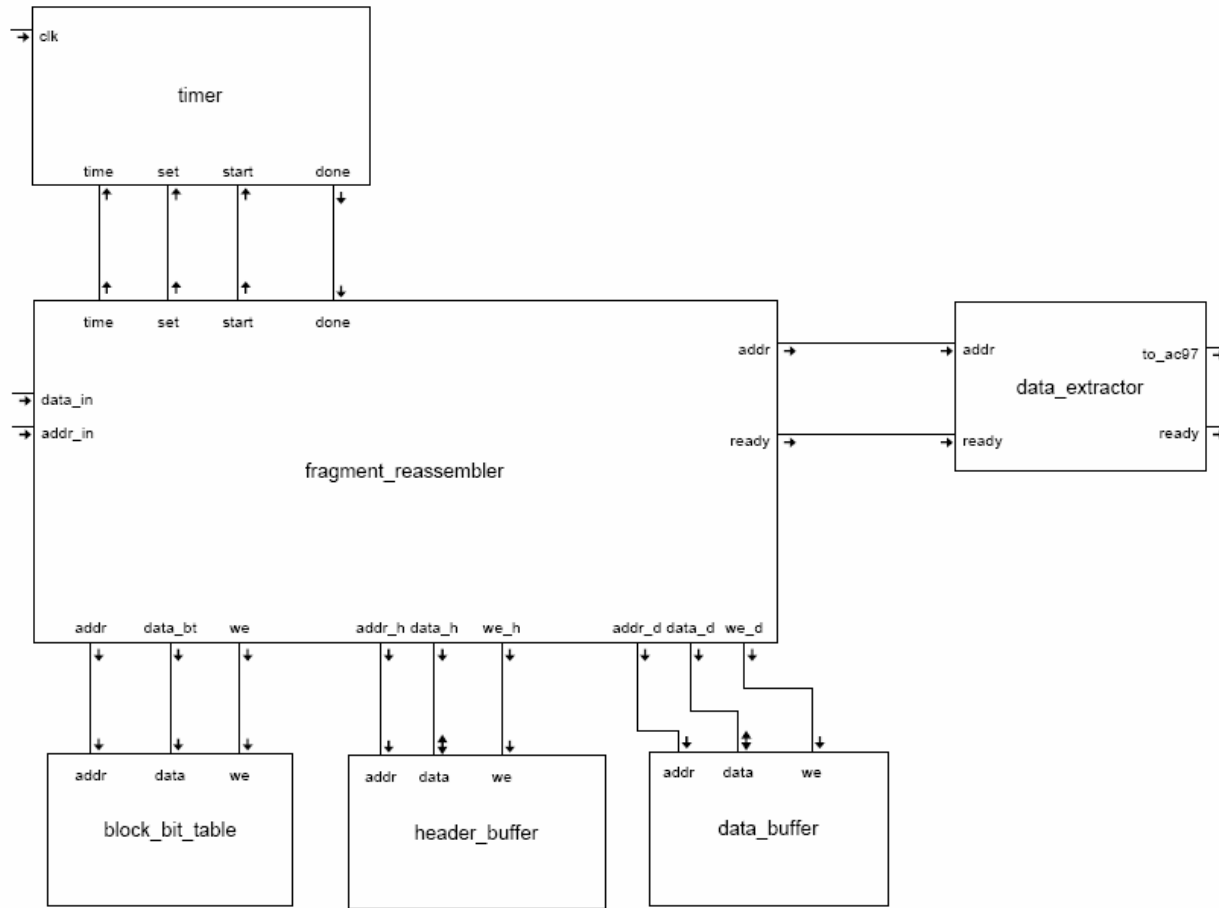

# IP Handler Encoder

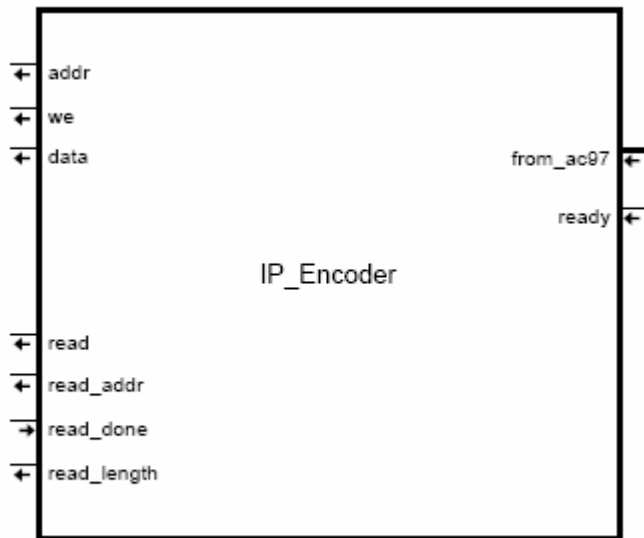

- Encodes IP packets using set IP addresses
- Writes data to RAM until it has collected enough to fill a packet

# Phone Controls

- Very similar to Lab 3
- Writes to IP handler instead of BRAM
- Down-samples to 16 bits instead of 8 bits
- Samples at 8kHz

# Timeline

Nov 13	14	15 Presentation	16	17	18 Check-off List Finalized	19
20 NET1 Interface researched and understood	21 IP Handler Encoder Complete	22	23	24	25	26
27 Data Sent/Received from Controller	28 IP Decoder w/o Fragmentation Complete	29	30 Controller Memory Modules Complete	Dec 1	2	3
4 Controller Module Complete	5 IP Decoder w/ Fragmentation Complete	6	7	8	9	10
11	12 Project Demo	13 Project Report Completed	14			