FPGA Telephone Exchange

Tristan Honscheid



Hardware Background

Landline Phones



Landline Phones - Interfacing



Can we hook these up to the labkit?

Yes, but some special interfacing circuitry is needed.

100-year-old technology meets modern digital logic.

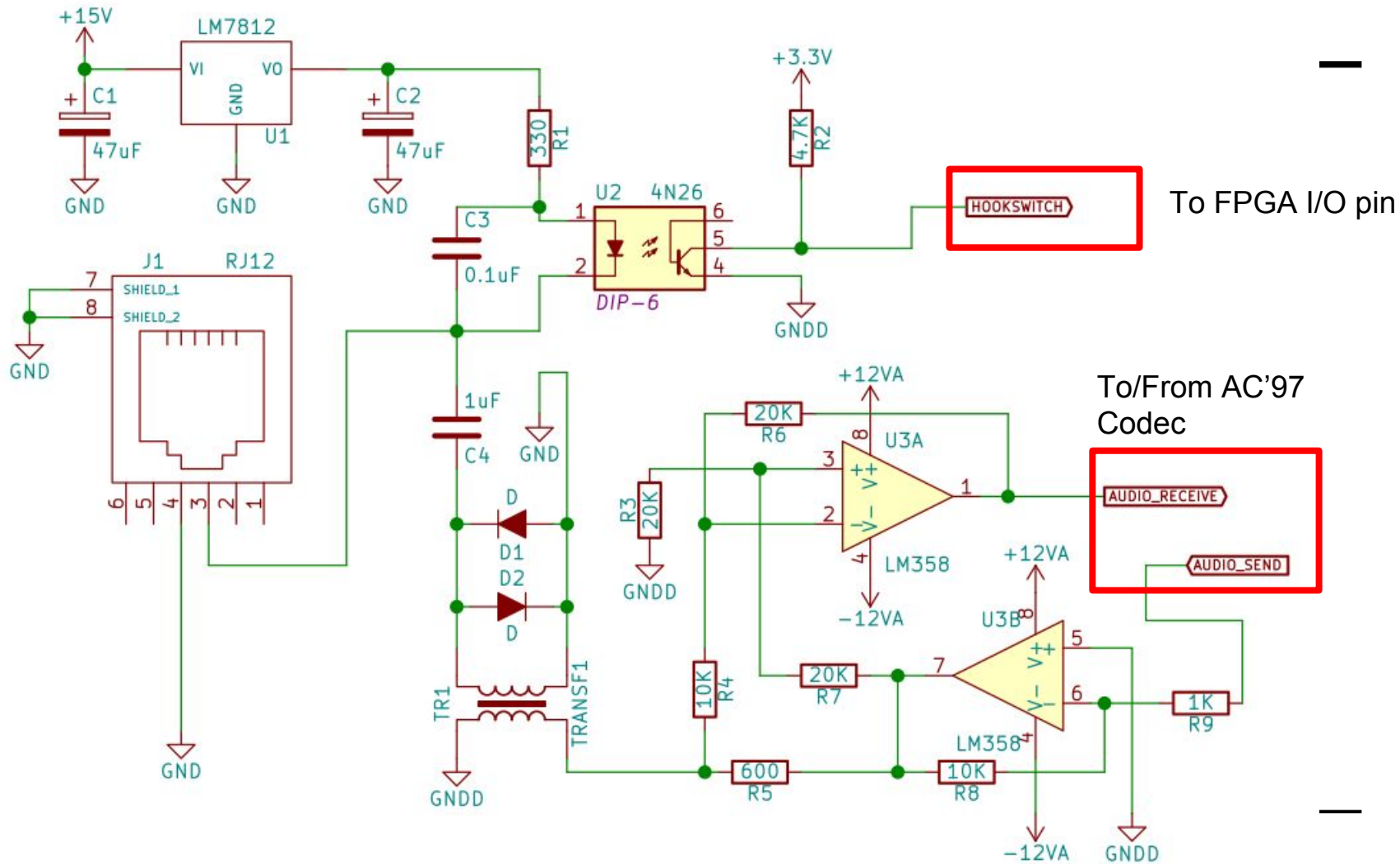

To FPGA I/O pin

To/From AC'97 Codec

Design Goal

We can now digitally interact with the phones (dialing, pickup, hangup, send/receive audio)

- Make an interactive phone exchange
 - Users can pick up and call each other
 - Realistic features like dial tone, busy tone, ringing tone, etc.
 - Display on VGA output for monitoring status
-

—

Black: Analog Audio
Blue: Digital Input
Orange: Digital Output

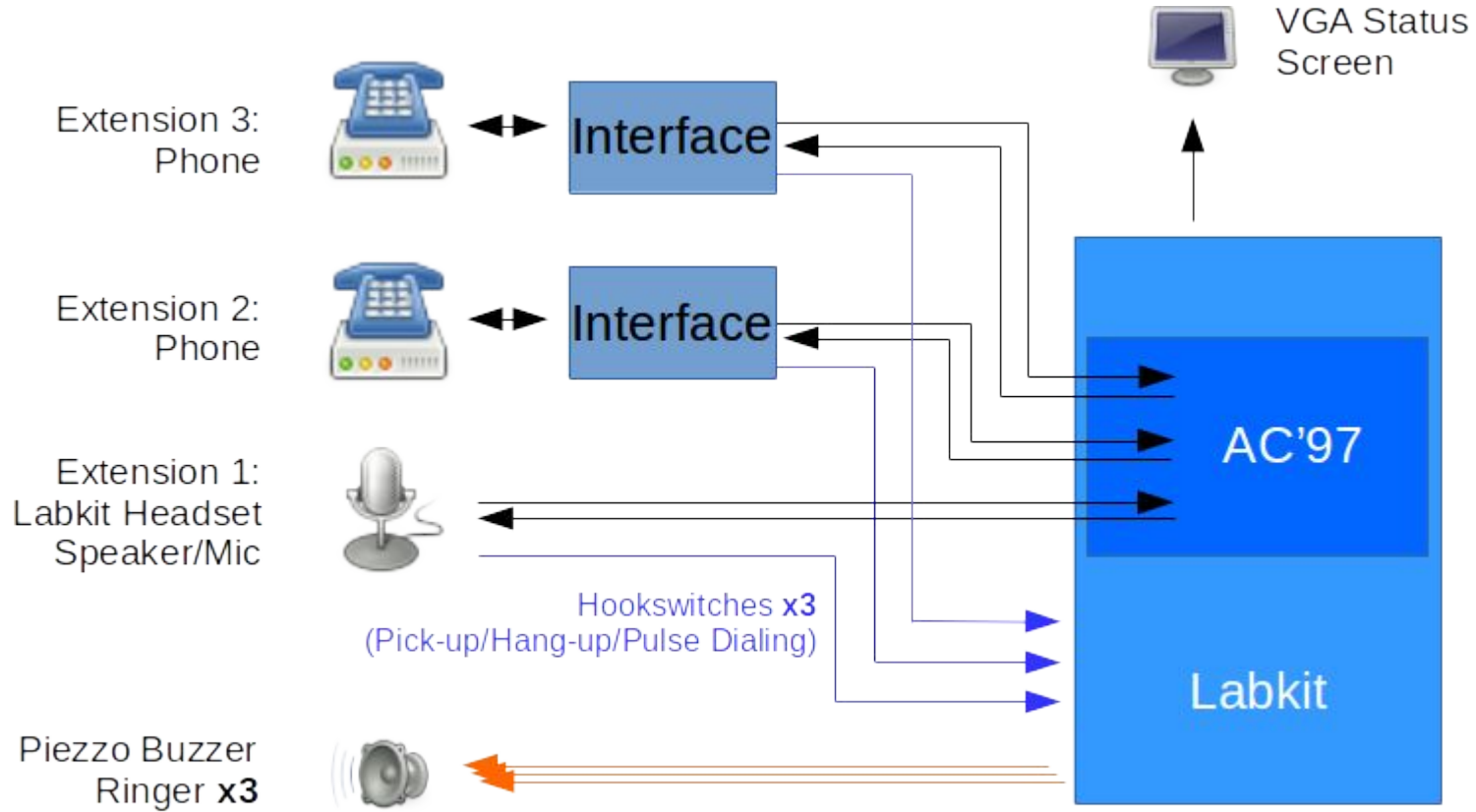

Overview

FPGA Modules

What do we need?

1. Layers of abstraction
 - a. Line Interface for the phones
 - b. Interface to the AC'97 audio ports
 - c. VGA character generator for status screen
 2. State machine for setting up and tearing down calls (PBX Core)
 3. Audio Router to make connections between the phones
-

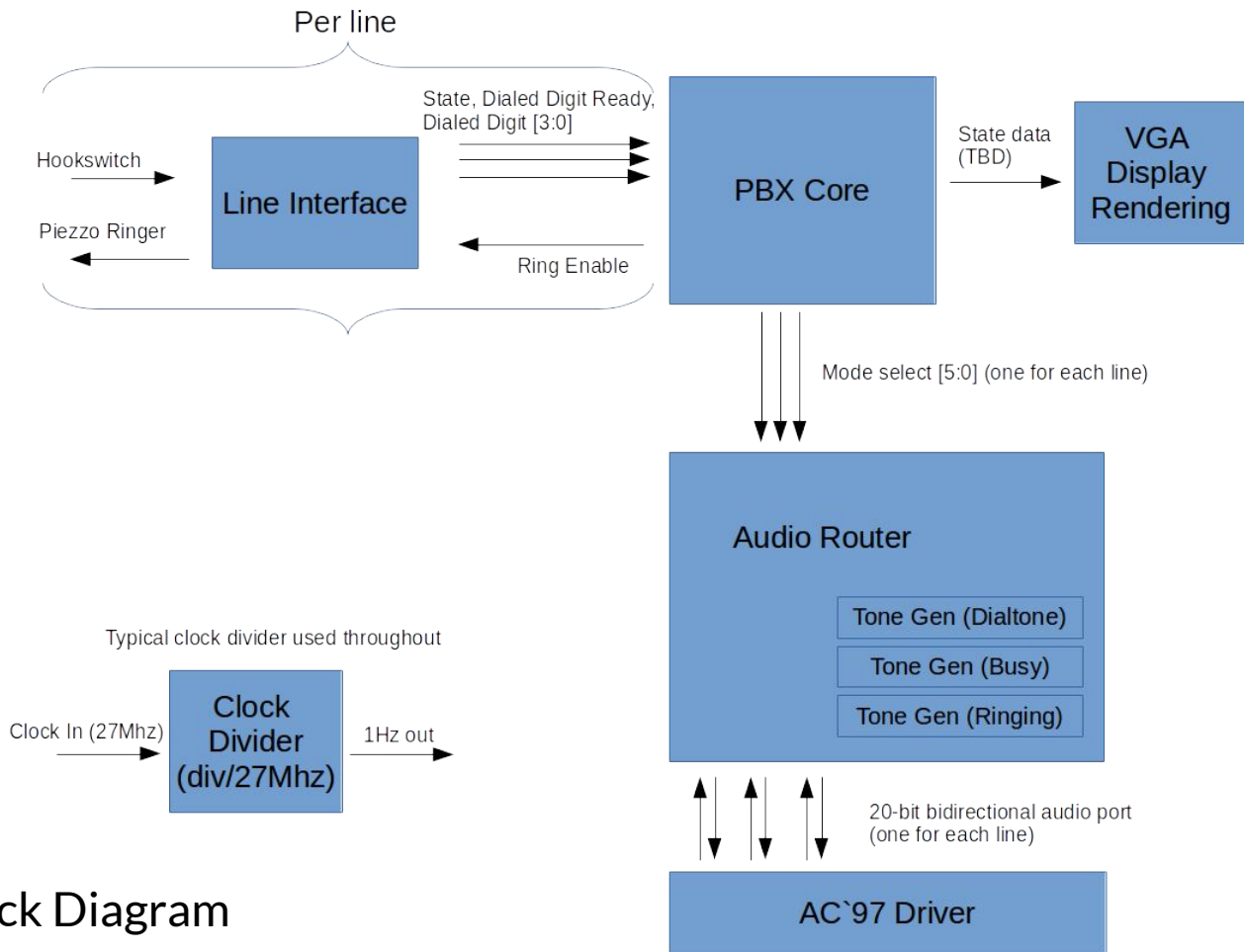

Working Block Diagram

Block Diagram

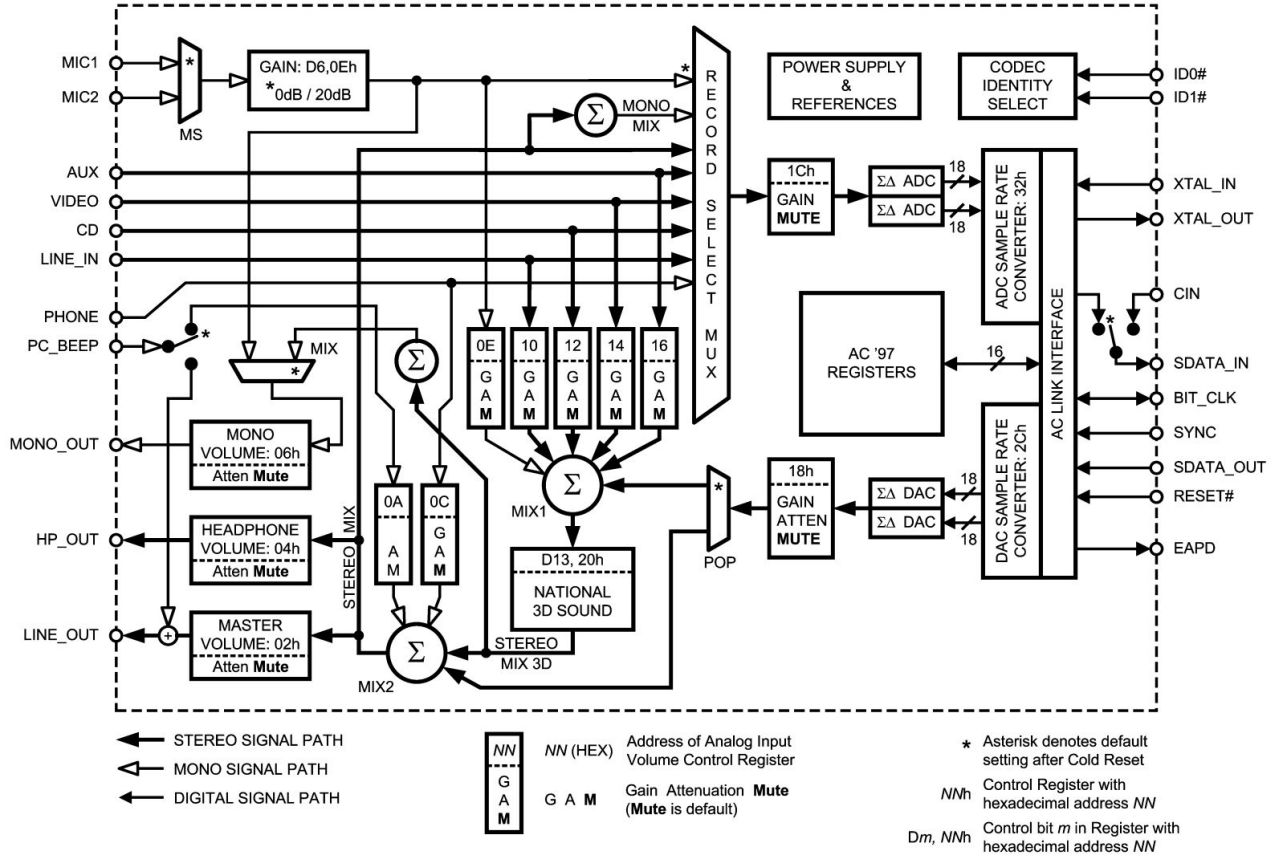

Stretch Goals

- Voicemail system. Use on-board memory to record messages if nobody picks up
 - Touch-tone (DTMF) dialing
-

Timeline

Week of 7 Nov: *HW Testing (phone and AC'97 interfacing)*

Week of 14 Nov: *Audio Router*

Week of 21 Nov: *Line interfaces, VGA status screen*

Week of 28 Nov: *PBX Core*

Weeks of 5 Dec, 12 Dec: *Debugging, Finalizing, Checkoff*
