



Logic Synthesis

- Primitive logic gates, universal gates
- Truth tables and sum-of-products
- Logic simplification
- Karnaugh Maps, Quine-McCluskey
- General implementation techniques:
muxes and look-up tables (LUTs)

Reminder: Lab #1 due this Thursday!



Lab Hours

Lab hours: eds.mit.edu/labs
 Sun 1-11:45p, M-R 9-11:45p, F 9-5p

6.111 Fall 2017: Schedule of Lab Coverage (Administrative interface)															
time:	12p	1p	2p	3p	4p	5p	6p	7p	8p	9p	10p	11p	12a	1a	2a
Sat	Lab Closed														
Sun						Elizabeth					Lab_closed				
Mon	Joe		Joe			Elizabeth			Lab_closed						
Tue	Gim				James			Diana					Lab_closed		
Wed	Joe		Joe			James			Weston					Lab_closed	
Thu				Gim			James			Diana			Lab_closed		
Fri	Mitchell		Mitchell						Lab closed						



Fall 2017

[Home](#)
[Announcements](#)

[Labkit](#)
[Handouts](#)
 » [Lectures](#)
 » [Labs:](#)
 » [Final Project info](#)

*MIT cert required
 *On-line Grades
 *Submit PDFs
 *Submit Verilog
 *Staffed Lab Hours

[Course info](#)
[Course objectives](#)
[Course calendar](#)

Late Policies

- Lab 1 check-offs - sign-up on checkoff queue in lab - FIFO during staffed lab hours. **Note bench number...**
- Please don't assume that *you* can wait until the last minute!
- No check-offs Saturday
- **Checkoff must start no later than 9PM**
- Lab grade = Checkoff + Verilog grade (~~equal weighting~~)
- Late labs:
 - 20%/day late penalty (no penalty for Saturday)
 - Max penalty 80% reduction.
 - Penalty waived for first 5 slack days. This covers illness, interviews, overload, etc. without S³ involvement.
- **A missing lab will result in a failing grade.** We've learned that if you're struggling with the labs, the final project won't go very well.
- Lpset - must be submitted on time.

Conflicts

week			MIT calendar	6.111	6.034
# 6.111 students who are also in the other subject:					16
% of 6.111 who are also in the other subject:					29%
	Oct 15	Sun			
7	Oct 16	Mon			
	Oct 17	Tue			
	Oct 18	Wed			Quiz 2
	Oct 19	Thu		Lab 5	
	Oct 20	Fri			
	Oct 21	Sat	Birth of Baha'u'llah		
	Oct 22	Sun			

week			MIT calendar	6.111	6.034
# 6.111 students who are also in the other subject:					16
% of 6.111 who are also in the other subject:					29%
	Nov 05	Sun			
10	Nov 06	Mon			
	Nov 07	Tue		Project presentation	
	Nov 08	Wed			Quiz 3
	Nov 09	Thu		Project Presentation	
	Nov 10	Fri	No classes (Veterans Day)		
	Nov 11	Sat			
	Nov 12	Sun			

Schematics & Wiring

- IC power supply connections generally not drawn. All integrated circuits need power!
- Use standard color coded wires to avoid confusion.
 - red: positive
 - black: ground or common reference point
 - Other colors: signals
- Circuit flow, signal flow left to right
- Higher voltage on top, ground negative voltage on bottom
- Neat wiring helps in debugging!

Wire Gauge

- Wire gauge: diameter is inversely proportional to the wire gauge number. Diameter increases as the wire gauge decreases. 2, 1, 0, 00, 000(3/0) up to 7/0.
- Resistance
 - 22 gauge .0254 in 16 ohm/1000 feet
 - 12 gauge .08 in 1.5 ohm/1000 feet
 - High voltage AC used to reduce loss
- 1 cm cube of copper has a resistance of 1.68 micro ohm (resistance of copper wire scales linearly : length/area)

CMOS Forever?

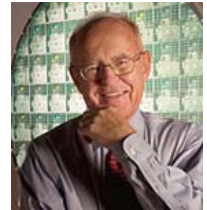

Mastering Moore's Law

Intel's progress in packing more transistors on mainstream microprocessor chips

Logarithmic scale

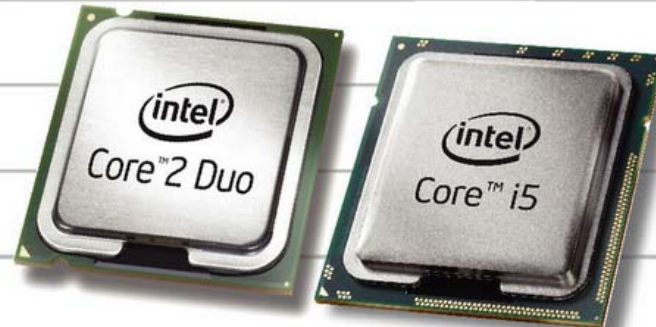
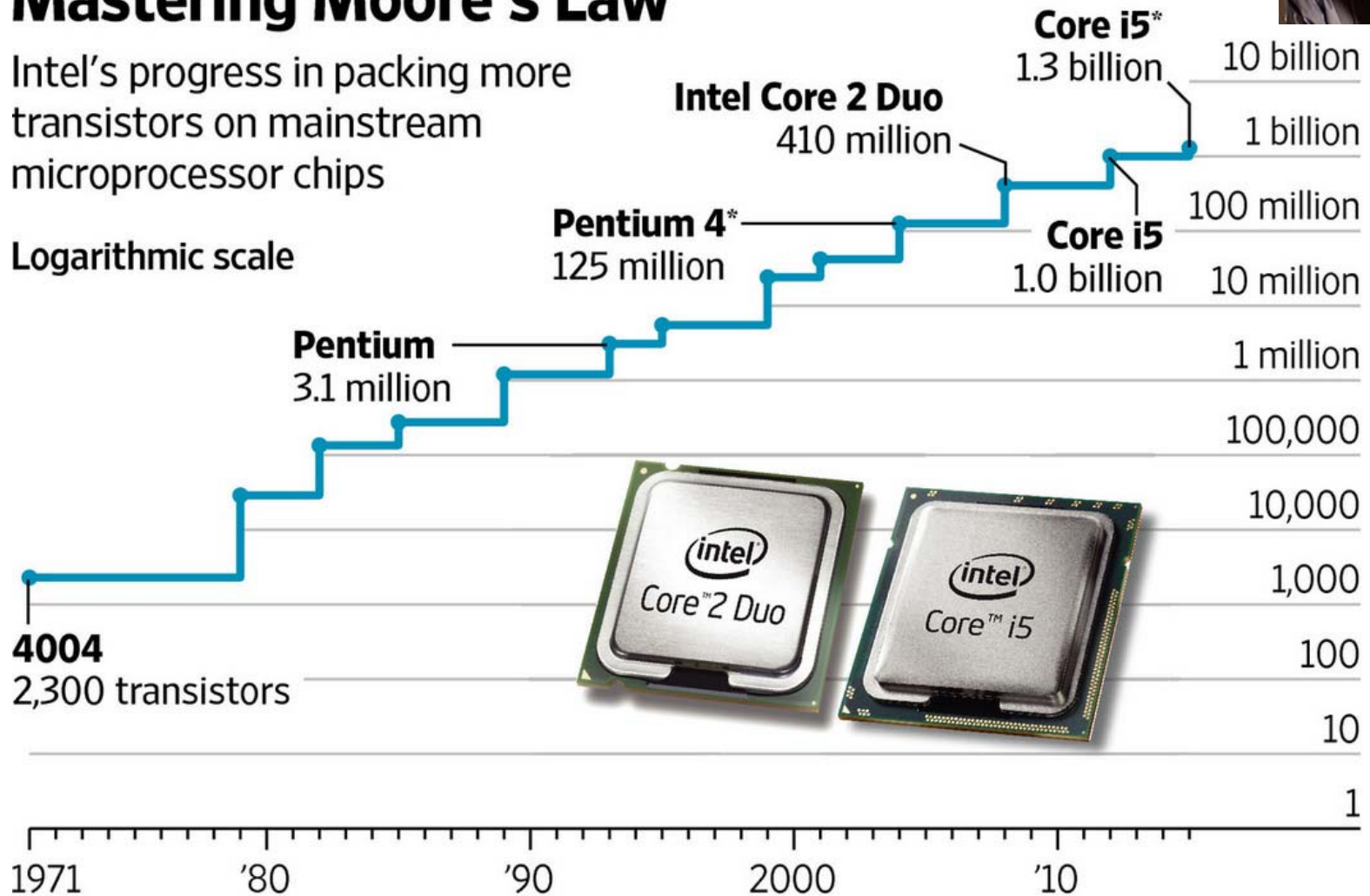

*Upgraded versions of prior models
Source: Intel

THE WALL STREET JOURNAL.

CMOS Forever?

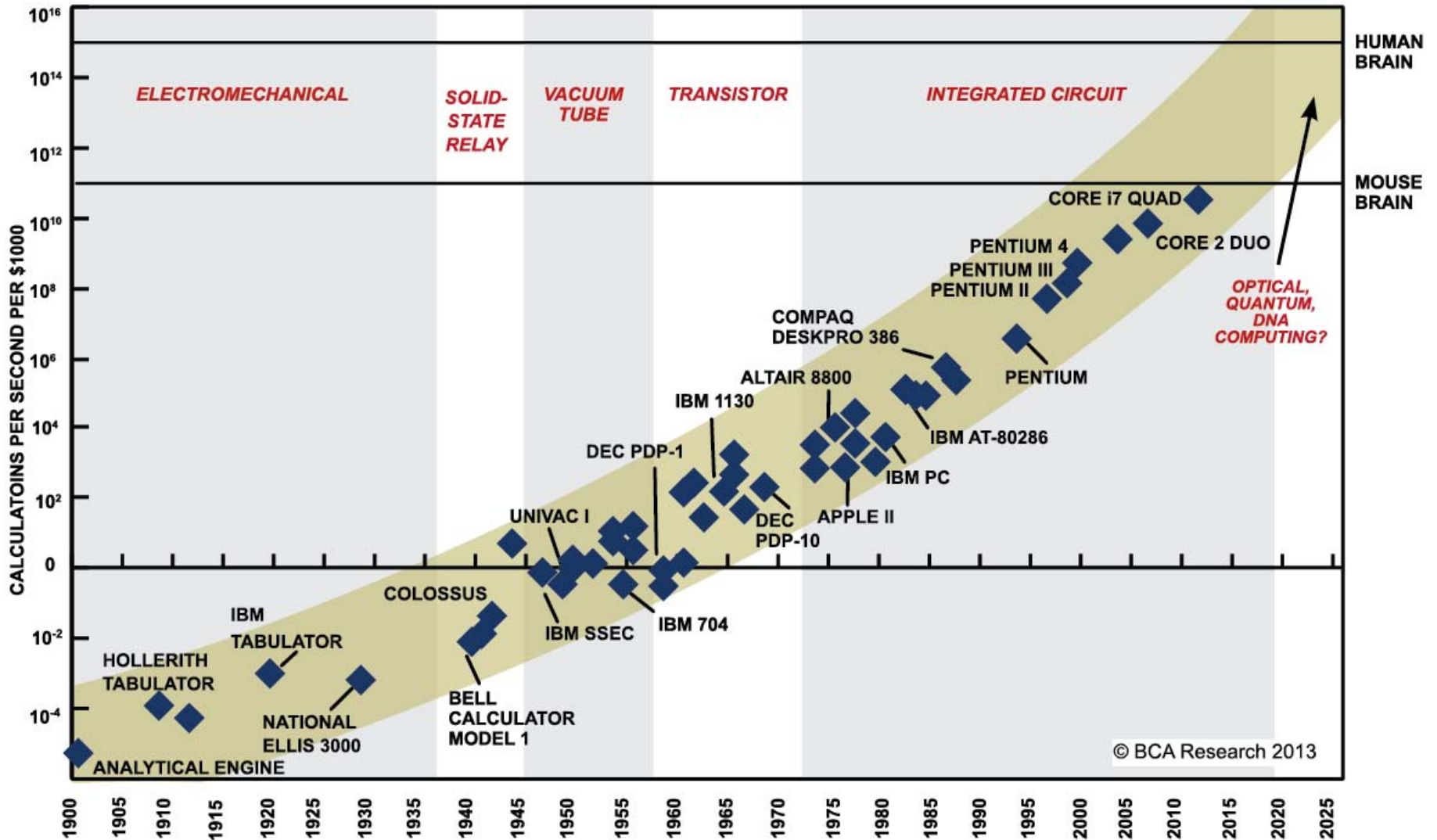

SOURCE: RAY KURZWEIL, "THE SINGULARITY IS NEAR: WHEN HUMANS TRANSCEND BIOLOGY", P.67, THE VIKING PRESS, 2006. DATAPOINTS BETWEEN 2000 AND 2012 REPRESENT BCA ESTIMATES.

Diminishing Returns *

Creating smaller circuitry has placed more transistors on chips but triggered higher costs.

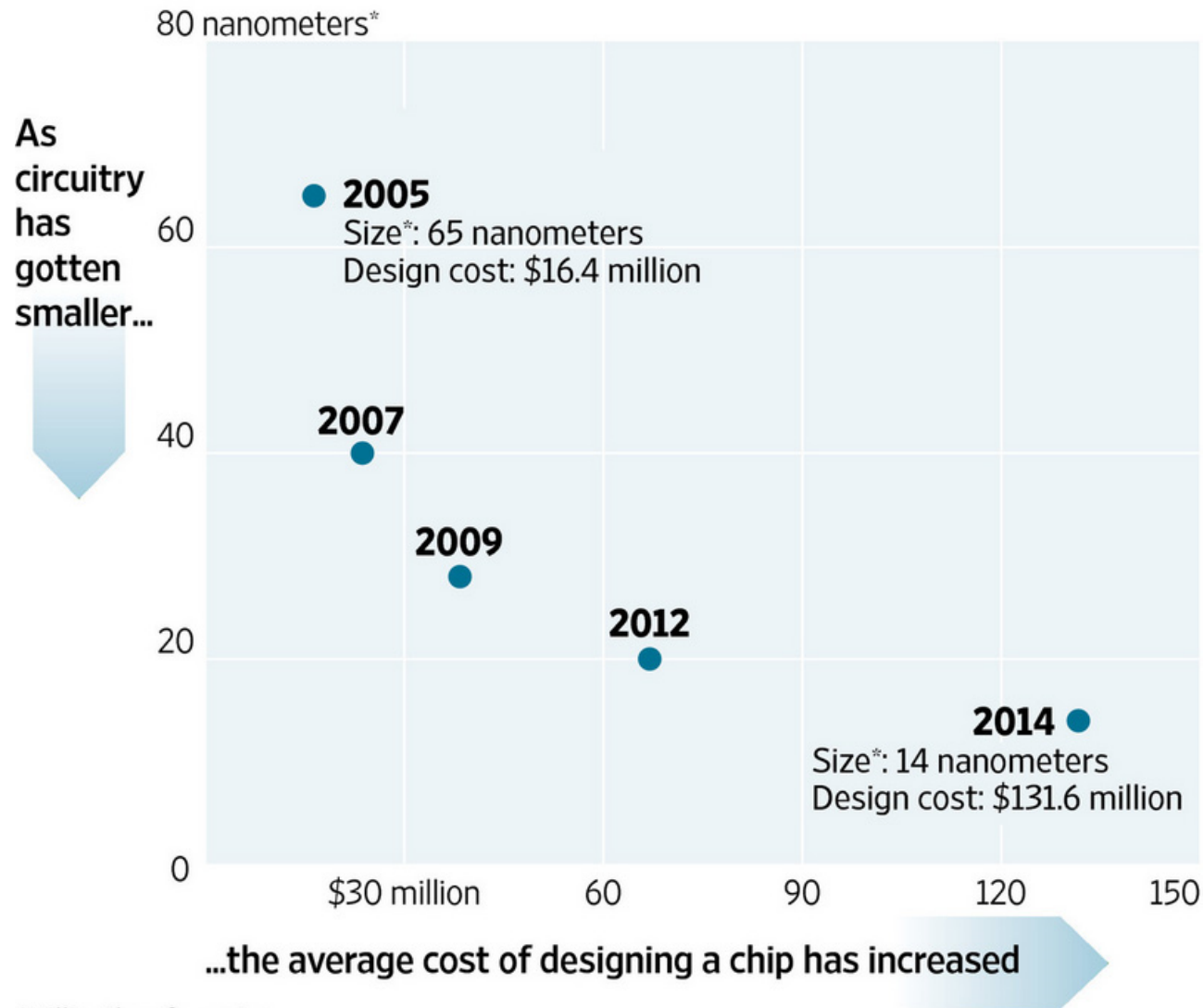

* Intel

*Billionths of a meter

Timing Specifications

Propagation delay (t_{PD}): An upper bound on the delay from valid inputs to valid outputs (aka " $t_{PD,MAX}$ ")

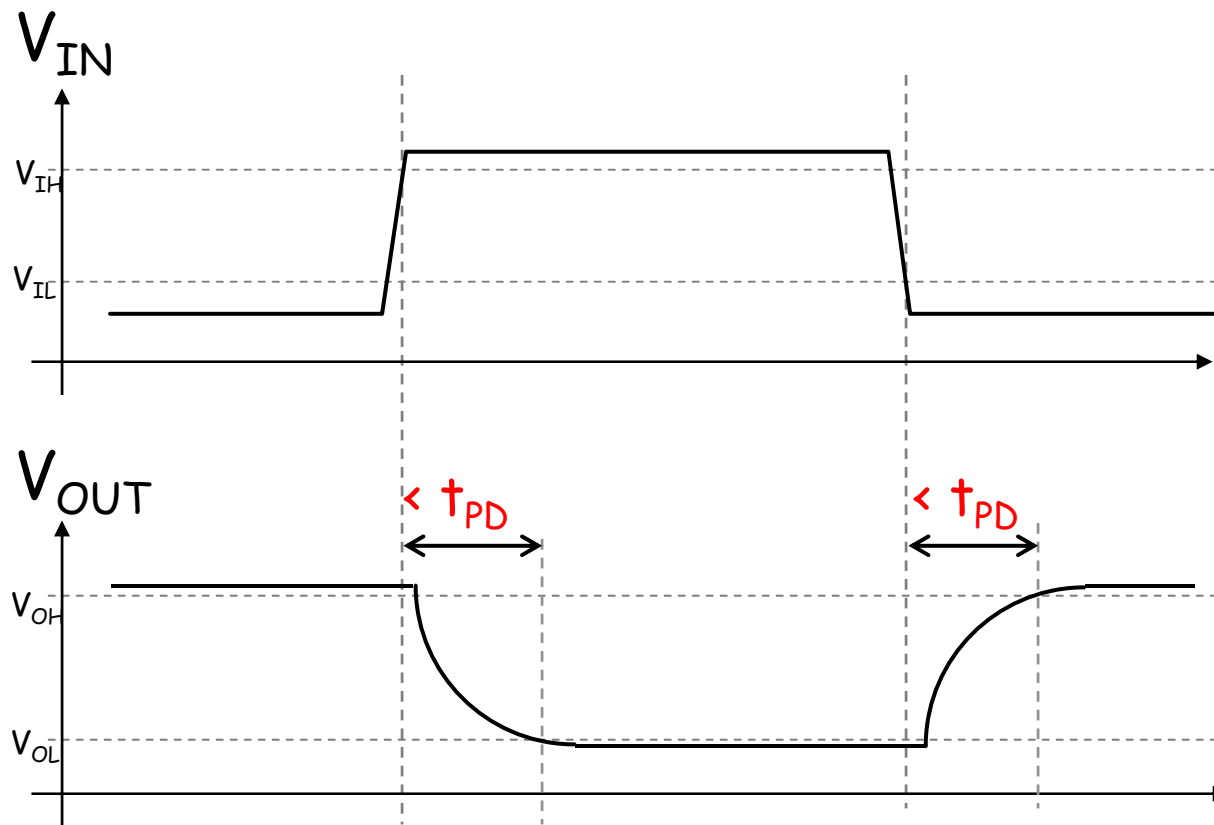

Design goal:
minimize
propagation
delay

Contamination Delay

an optional, additional timing spec

Contamination delay (t_{CD}): A lower bound on the delay from invalid inputs to invalid outputs (aka “ $t_{PD,MIN}$ ”)

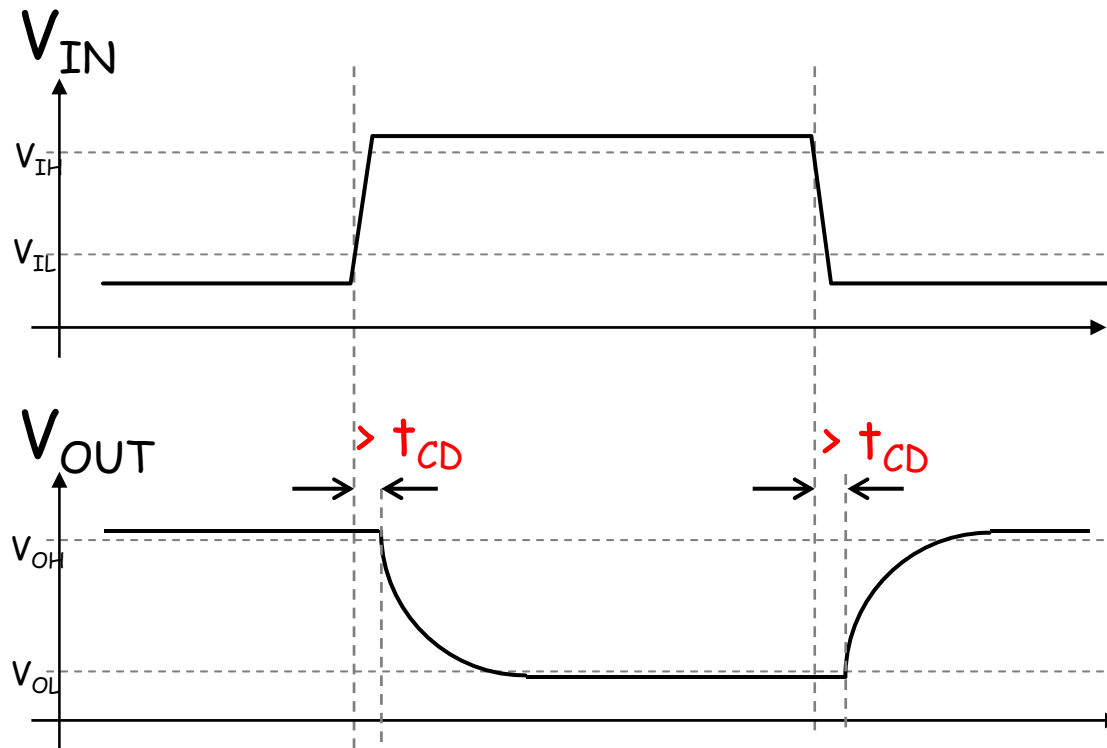

Do we really need t_{CD} ?

Usually not... it'll be important when we design circuits with registers (coming soon!)

If t_{CD} is not specified, safe to assume it's 0.

The Combinational Contract

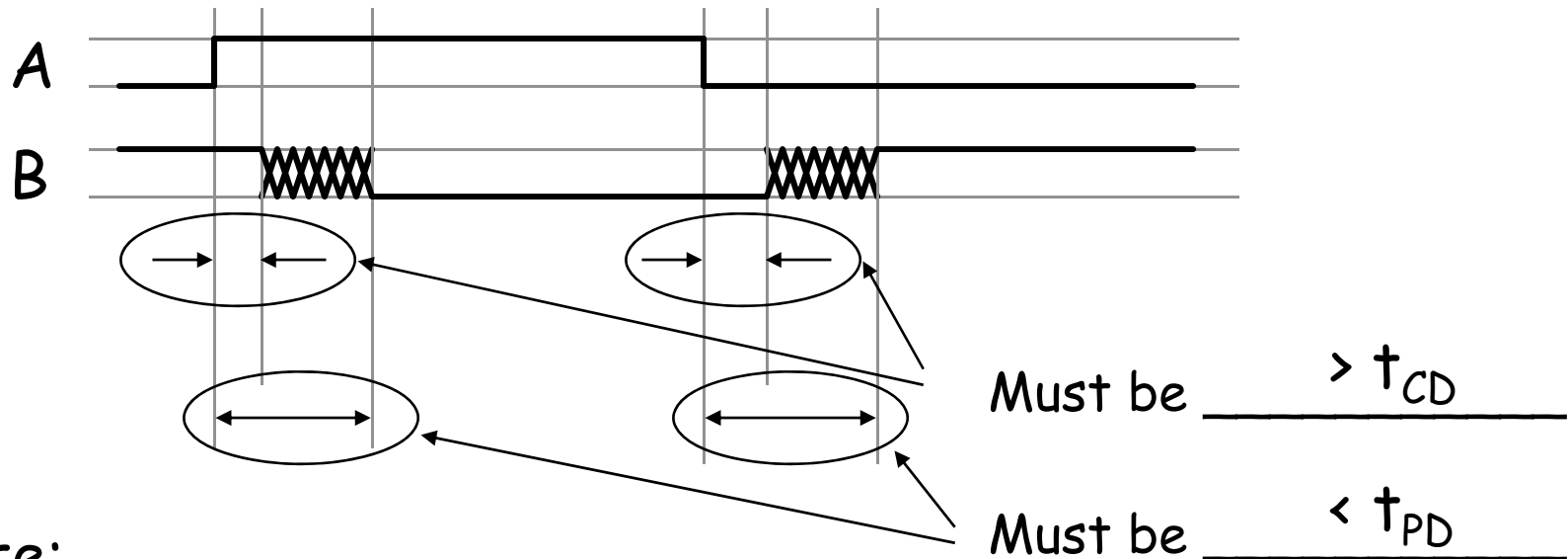
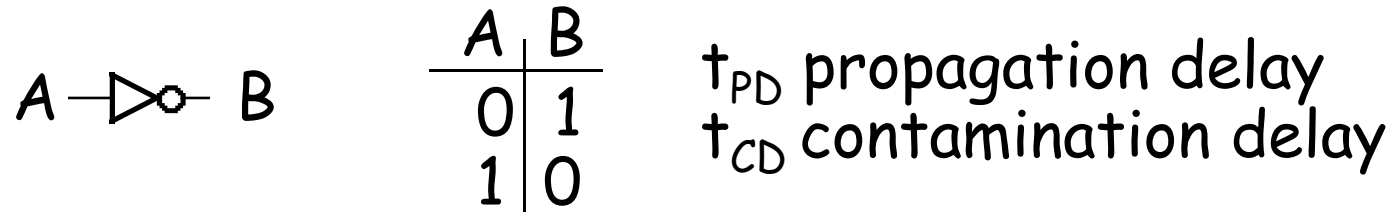

Note:

1. *No Promises* during XXXXXX
2. Default (conservative) spec: $t_{CD} = 0$

Functional Specifications

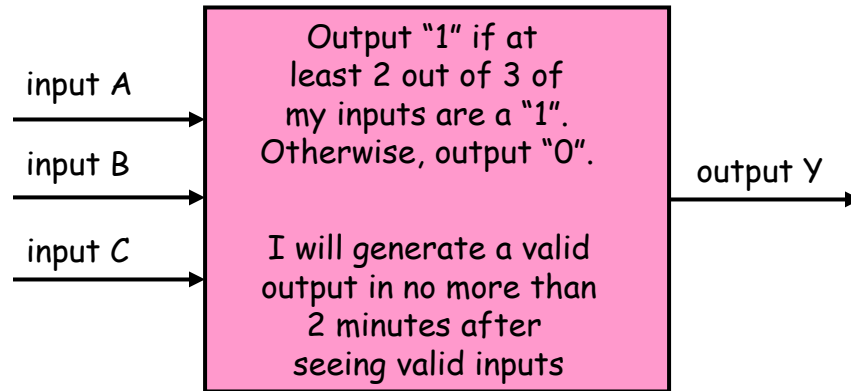

A	B	C	Y
0	0	0	0
0	0	1	0
0	1	0	0
0	1	1	1
1	0	0	0
1	0	1	1
1	1	0	1
1	1	1	1

*3 binary inputs
so $2^3 = 8$ rows in our truth table*

An concise, unambiguous technique for giving the functional specification of a combinational device is to use a *truth table* to specify the output value for each possible combination of input values (N binary inputs $\rightarrow 2^N$ possible combinations of input values).

Here's a Design Approach

1. Write out our functional spec as a truth table
2. Write down a Boolean expression with terms covering each '1' in the output:

A	B	C	Y
0	0	0	0
0	0	1	0
0	1	0	0
0	1	1	1
1	0	0	0
1	0	1	1
1	1	0	1
1	1	1	1

$$Y = \bar{A} \cdot B \cdot C + A \cdot \bar{B} \cdot C + A \cdot B \cdot \bar{C} + A \cdot B \cdot C$$

This approach creates equations of a particular form called

SUM-OF-PRODUCTS

Sum (+): ORs

Products (\cdot): ANDs

- it's systematic!
- it works!
- it's easy!
- are we done yet???



S-O-P Building Blocks

INVERTER:

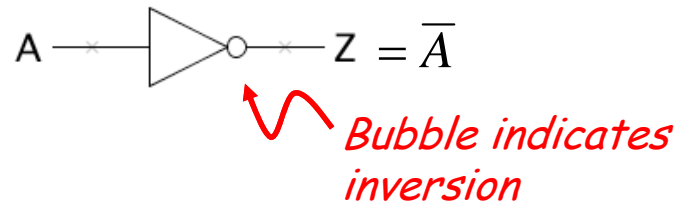

A	Z
0	1
1	0

AND:

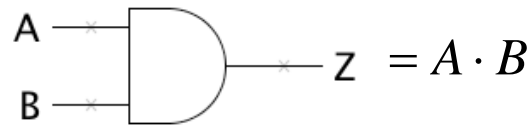

A	B	Z
0	0	0
0	1	0
1	0	0
1	1	1

OR:

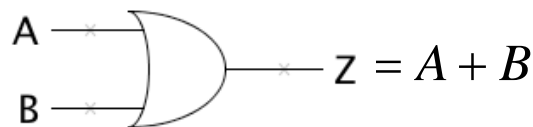

A	B	Z
0	0	0
0	1	1
1	0	1
1	1	1

Straightforward Synthesis

$$Y = \bar{A} \cdot B \cdot C + A \cdot \bar{B} \cdot C + A \cdot B \cdot \bar{C} + A \cdot B \cdot C$$

We can use

SUM-OF-PRODUCTS
to implement *any* logic
function.

Only need 3 gate types:
INVERTER, AND, OR

Propagation delay:

- 3 levels of logic
- No more than 3 gate delays assuming gates with an arbitrary number of inputs. But, in general, we'll only be able to use gates with a bounded number of inputs (bound is ~ 4 for most logic families).

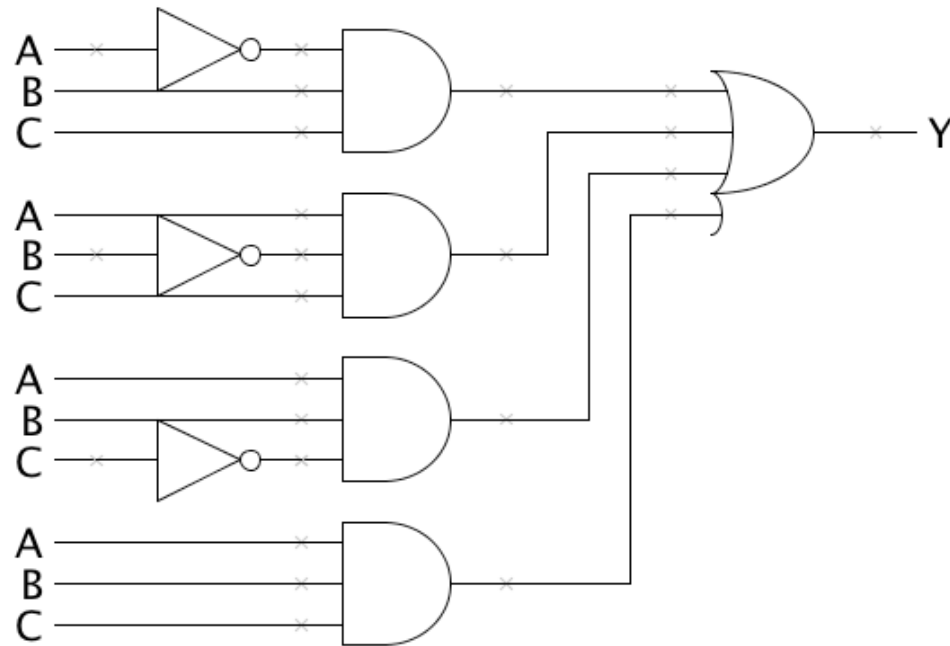

ANDs and ORs with > 2 inputs

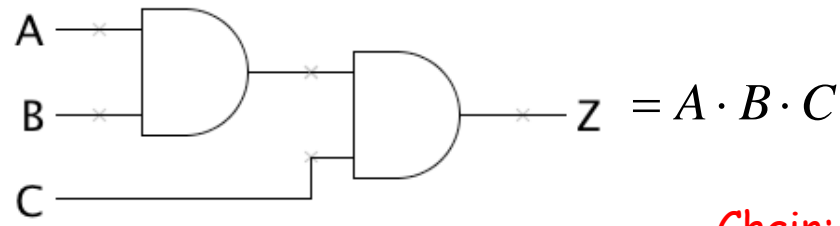

Chain: Propagation delay increases linearly with number of inputs

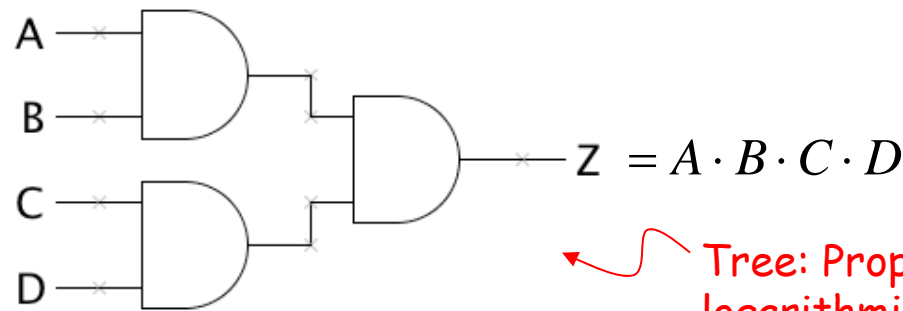
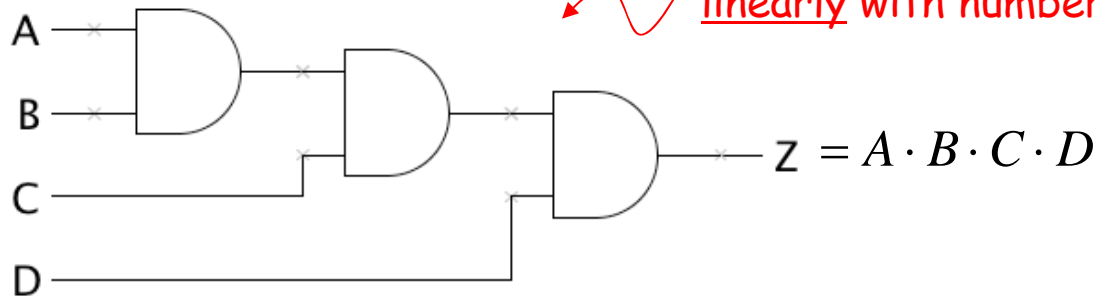

Which one should I use?



Tree: Propagation delay increases logarithmically with number of inputs

SOP w/ 2-input gates

Previous example restricted to 2-input gates:

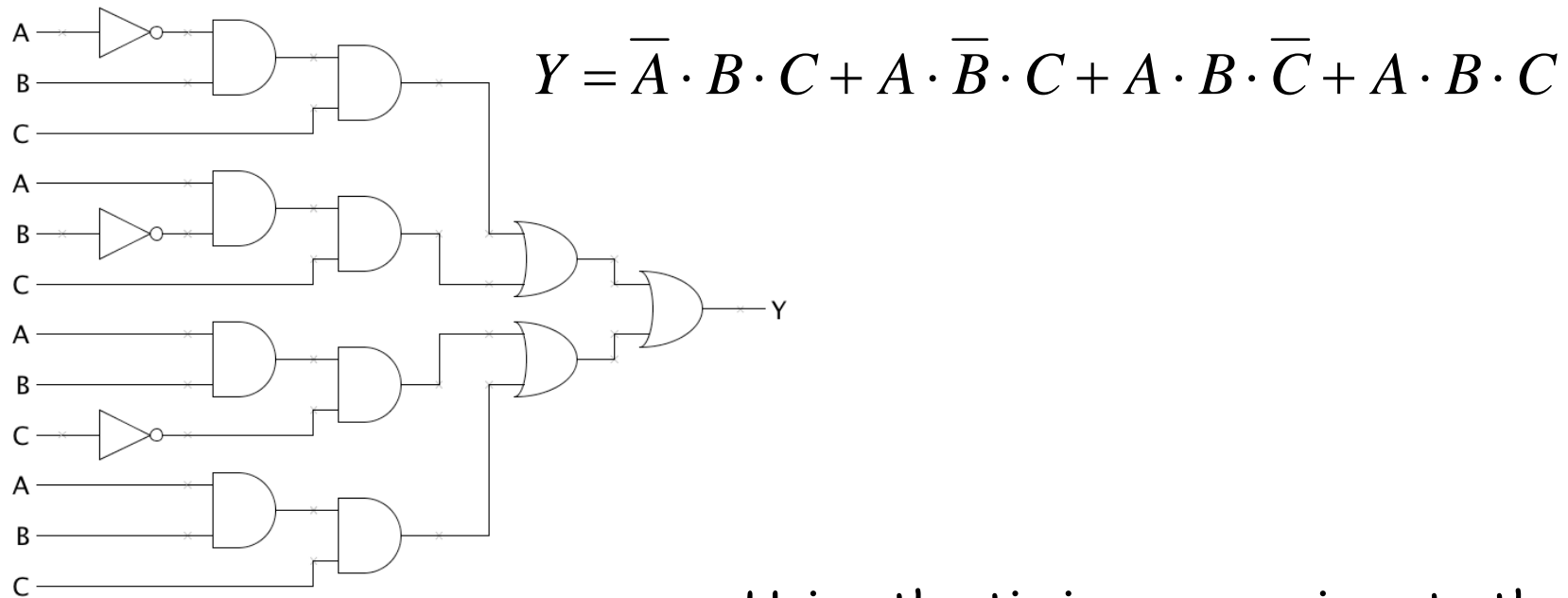

	INV	AND2	OR2
t_{PD}	8ps	15ps	18ps
t_{CD}	1ps	3ps	3ps

Using the timing specs given to the left, what are t_{PD} and t_{CD} for this combinational circuit?

Hint: to find overall t_{PD} we need to find $\max t_{PD}$ considering all paths from inputs to outputs.

More Building Blocks

NAND (not AND)

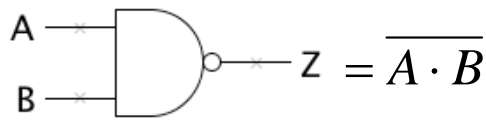

A	B	Z
0	0	1
0	1	1
1	0	1
1	1	0

NOR (not OR)

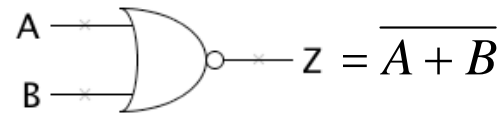

A	B	Z
0	0	1
0	1	0
1	0	0
1	1	0

CMOS gates are naturally inverting so we want to use NANDs and NORs in CMOS designs...

XOR (exclusive OR)

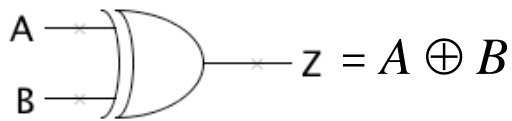

A	B	Z
0	0	0
0	1	1
1	0	1
1	1	0

XOR is very useful when implementing parity and arithmetic logic. Also used as a "programmable inverter": if $A=0$, $Z=B$; if $A=1$, $Z=\sim B$

Wide fan-in XORs can be created with chains or trees of 2-input XORs.

NAND - NOR Internals

Dual-In-Line Package

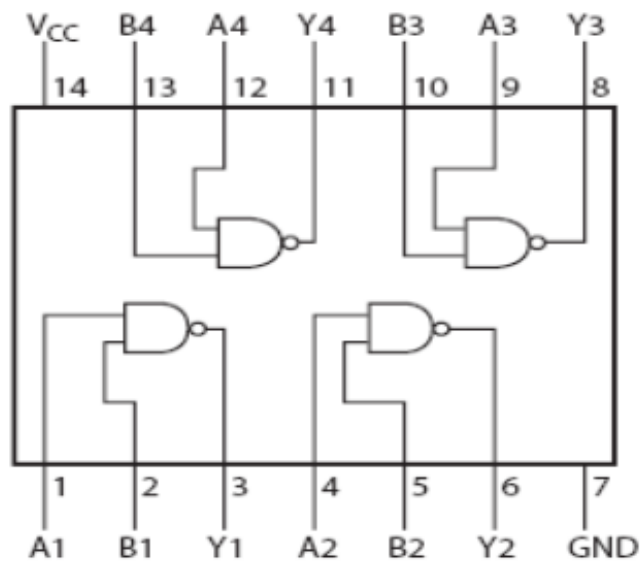

This device contains four independent gates each of which performs the logic NAND function.

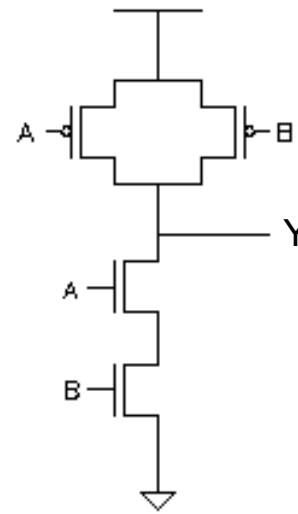

NAND

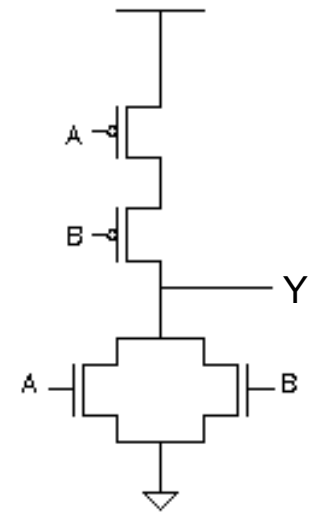

NOR

Universal Building Blocks

NANDs and NORs are universal:

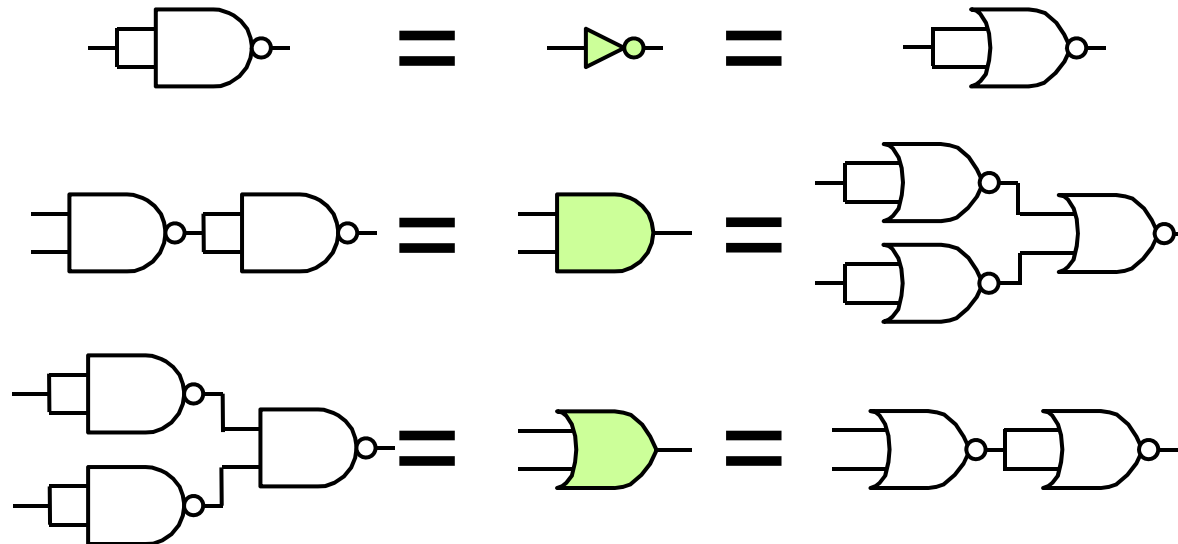

Any logic function can be implemented using only NANDs (or, equivalently, NORs). Note that chaining/treeing technique doesn't work directly for creating wide fan-in NAND or NOR gates. But wide fan-in gates can be created with trees involving both NANDs, NORs and inverters.

SOP with NAND/NOR

When designing with NANDs and NORs one often makes use of De Morgan's laws:

NAND form: $\overline{A \cdot B} = \overline{A} + \overline{B}$

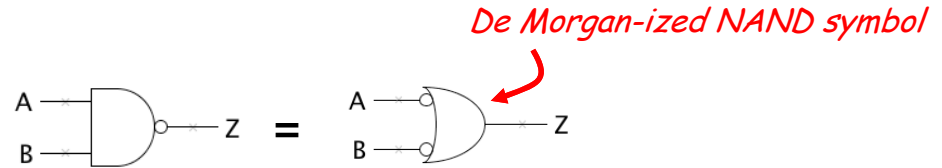

NOR form: $\overline{A + B} = \overline{A} \cdot \overline{B}$

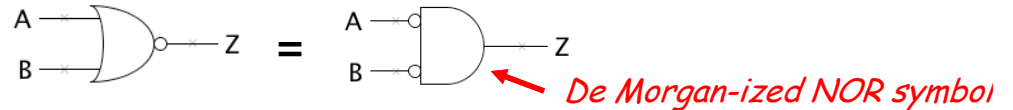

So the following "SOP" circuits are all equivalent (note the use of De Morgan-ized symbols to make the inversions less confusing):

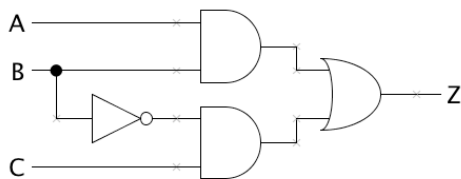

AND/OR form

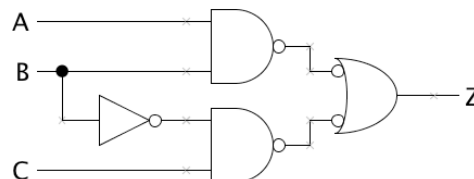

NAND/NAND form

This will be handy in Lab 1 since you'll be able to use just 7400's to implement your circuit!

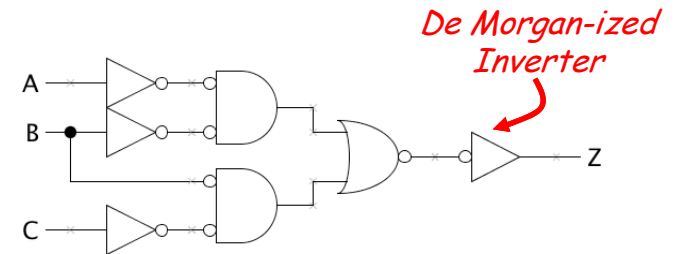

NOR/NOR form

All these "extra" inverters may seem less than ideal but often the buffering they provide will reduce the capacitive load on the inputs and increase the output drive.

Logic Simplification

- Can we implement the same function with fewer gates? Before trying we'll add a few more tricks in our bag.

- **BOOLEAN ALGEBRA:**

OR rules: $a+1=1$ $a+0=a$ $a+a=a$

AND rules: $a \cdot 1=a$ $a \cdot 0=0$ $a \cdot a=a$

Commutative: $a+b=b+a$ $a \cdot b=b \cdot a$

Associative: $(a+b)+c=a+(b+c)$ $(a \cdot b) \cdot c=a \cdot (b \cdot c)$

Distributive: $a \cdot (b+c)=a \cdot b+a \cdot c$ $a+b \cdot c=(a+b) \cdot (a+c)$

Complements: $a+\bar{a}=1$ $a \cdot \bar{a}=0$

Absorption: $a+a \cdot b=a$ $a+\bar{a} \cdot b=a+b$ $a \cdot (a+b)=a$ $a \cdot (\bar{a}+b)=a \cdot b$

De Morgan's Law: $\overline{a \cdot b}=\bar{a}+\bar{b}$ $\overline{a+b}=\bar{a} \cdot \bar{b}$

Reduction: $a \cdot b+\bar{a} \cdot b=b$ $(a+b) \cdot (\bar{a}+b)=b$



Key to simplification: equations that match the pattern of the LHS (where "b" might be any expression) tell us that when "b" is true, the value of "a" doesn't matter. So "a" can be eliminated from the equation, getting rid of two 2-input ANDs and one 2-input OR.

Boolean Minimization:

An Algebraic Approach

Lets simplify the equation from slide #3:

$$Y = \bar{A} \cdot B \cdot C + A \cdot \bar{B} \cdot C + A \cdot B \cdot \bar{C} + A \cdot B \cdot C$$

Using the identity

$$\alpha A + \alpha \bar{A} = \alpha$$

For any expression α and variable A :

$$Y = \bar{A} \cdot B \cdot C + A \cdot \bar{B} \cdot C + A \cdot B \cdot \bar{C} + A \cdot B \cdot C$$

$$Y = B \cdot C + A \cdot C + A \cdot B$$

The tricky part: some terms participate in more than one reduction so can't do the algebraic steps one at a time!

Karnaugh Maps: A Geometric Approach

K-Map: a truth table arranged so that terms which differ by exactly one variable are adjacent to one another so we can see potential reductions easily.

A	B	C	Y
0	0	0	0
0	0	1	0
0	1	0	0
0	1	1	1
1	0	0	0
1	0	1	1
1	1	0	1
1	1	1	1

Here's the layout of a 3-variable K-map filled in with the values from our truth table:

		AB			
		00	01	11	10
C	Y	0	0	1	0
	1	0	1	1	1

Why did he shade that row Gray?



It's cyclic. The left edge is adjacent to the right edge. It's really just a flattened out cube.

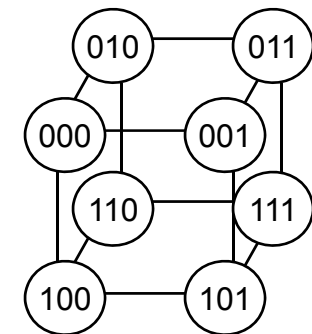

On to Hyperspace

Here's a 4-variable K-map:

		AB			
		00	01	11	10
CD	Z	00	01	11	10
	00	1	0	0	1
	01	0	0	0	0
	11	1	1	0	1
10	1	1	0	1	

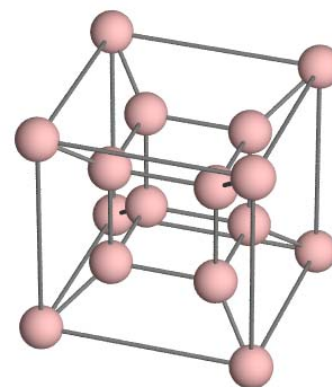

Again it's cyclic. The left edge is adjacent to the right edge, and the top is adjacent to the bottom.

We run out of steam at 4 variables - K-maps are hard to draw and use in three dimensions (5 or 6 variables) and we're not equipped to use higher dimensions (> 6 variables)!

Finding Subcubes

We can identify clusters of "irrelevant" variables by circling adjacent subcubes of 1s. A subcube is just a lower dimensional cube.

		AB			
Y		00	01	11	10
C	0	0	0	1	0
	1	0	1	1	1

Three 2x1 subcubes

		AB			
Z		00	01	11	10
CD	00	1	0	0	1
	01	0	0	0	0
	11	1	1	0	1
	10	1	1	0	1

Three 2x2 subcubes

The best strategy is generally a greedy one.

- Circle the largest N-dimensional subcube (2^N adjacent 1's)
4x4, 4x2, 4x1, 2x2, 2x1, 1x1
- Continue circling the largest remaining subcubes
(even if they overlap previous ones)
- Circle smaller and smaller subcubes until no 1s are left.

Write Down Equations

Write down a product term for the portion of each cluster/subcube that is invariant. You only need to include enough terms so that all the 1's are covered. Result: a **minimal sum of products** expression for the truth table.

		AB			
		00	01	11	10
C	0	0	0	1	0
	1	0	1	1	1

$Y = A \cdot C + B \cdot C + A \cdot B$

		AB			
		00	01	11	10
CD	00	1	0	0	1
	01	0	0	0	0
	11	1	1	0	1
	10	1	1	0	1

$Z = \bar{B} \cdot \bar{D} + \bar{B} \cdot C + \bar{A} \cdot C$

We're done!



Morse Code to ASCII Exercise

- Morse code - variable length encoding, 6 bits max
 - Letter "e" •
 - Period • ■ ■ • ■ ■
- ASCII (American Standard Code for Information Interchange)
 - 8 bit binary representation of text
- How many bits are required to represent any morse code input?

A	010	φφφφ	10	0	1	0	0	0	0	0	1
B	110	φφ	0001	0	1	0	0	0	0	1	0
C	001	φφ	0101	1	1	0	0	0	0	1	1
D	110	φφφ	001	0	1	0	0	0	1	0	0
E	100	φφφφφ	0	1	1	0	0	0	1	0	1
F	001	φφ	0100	1	1	0	0	0	1	1	0
G	110	φφφ	011	0	1	0	0	0	1	1	1
H	001	φφ	0000	0	1	0	0	1	0	0	0
I	010	φφφφ	00	1	1	0	0	1	0	0	1
J	001	φφ	1110	1	1	0	0	1	0	1	0
K	110	φφφ	101	0	1	0	0	1	0	1	1
L	001	φφ	0010	1	1	0	0	1	1	0	0
M	010	φφφφ	11	0	1	0	0	1	1	0	0
N	010	φφφφ	01	0	1	0	0	1	1	1	0
O	φ1	0φφφ	111	1	1	0	0	1	1	1	1
P	001	φφ	0110	0	1	0	1	0	0	0	0
Q	001	φφ	1011	1	1	0	1	0	0	0	1
R	110	φφφ	010	1	1	0	1	0	0	1	0
S	110	φφφ	000	0	1	0	1	0	0	1	1

m_1, m_2	00	01	11	10
M_3	0	S	R	C
	1	U	W	O
				K

m_1, m_2	00	01	11	10
M_3, M_4	00	H	L	Z
	01	V	φ	φ
	10	φ	J	φ
	10	F	P	φ
				C

Two-Level Boolean Minimization

Two-level Boolean minimization is used to find a sum-of-products representation for a multiple-output Boolean function that is optimum according to a given cost function. The typical cost functions used are the number of product terms in a two-level realization, the number of literals, or a combination of both. The two steps in two-level Boolean minimization are:

- Generation of the set of prime product-terms for a given function.
- Selection of a minimum set of prime terms to implement the function.

We will briefly describe the Quine-McCluskey method which was the first algorithmic method proposed for two-level minimization and which follows the two steps outlined above. State-of-the-art logic minimization algorithms are all based on the Quine-McCluskey method and also follow the two steps above.

Prime Term Generation

Start by expressing your Boolean function using 0-terms (product terms with no don't care care entries). For compactness the table for example 4-input, 1-output function $F(w,x,y,z)$ shown to the right includes only entries where the output of the function is 1 and we've labeled each entry with it's decimal equivalent.

$$F = f(W,X,Y,Z)$$

W	X	Y	Z	label
0	0	0	0	0
0	1	0	1	5
0	1	1	1	7
1	0	0	0	8
1	0	0	1	9
1	0	1	0	10
1	0	1	1	11
1	1	1	0	14
1	1	1	1	15

Look for pairs of 0-terms that differ in only one bit position and merge them in a 1-term (i.e., a term that has exactly one '-' entry). Next 1-terms are examined in pairs to see if they can be merged into 2-terms, etc. Mark k-terms that get merged into (k+1) terms so we can discard them later.

1-terms:

0, 8	-000	[A]
5, 7	01-1	[B]
7, 15	-111	[C]
8, 9	100-	
8, 10	10-0	
9, 11	10-1	
10, 11	101-	
10, 14	1-10	
11, 15	1-11	
14, 15	111-	

2-terms:

8, 9, 10, 11	10--	[D]
10, 11, 14, 15	1-1-	[E]

3-terms: none!

Label unmerged terms:
these terms are prime!

Example due to
Srini Devadas

Prime Term Table

An "X" in the prime term table in row R and column K signifies that the 0-term corresponding to row R is contained by the prime corresponding to column K.

Goal: select the minimum set of primes (columns) such that there is at least one "X" in every row. This is the classical minimum covering problem.

	A	B	C	D	E	
0000	X	→ A is essential -000
0101	.	X	.	.	.	→ B is essential 01-1
0111	.	X	X	.	.	
1000	X	.	.	X	.	
1001	.	.	.	X	.	→ D is essential 10--
1010	.	.	.	X	X	
1011	.	.	.	X	X	
1110	X	→ E is essential 1-1-
1111	.	.	X	.	X	

Each row with a single X signifies an essential prime term since any prime implementation will have to include that prime term because the corresponding 0-term is not contained in any other prime.

In this example the essential primes "cover" all the 0-terms.

$$F = f(W, X, Y, Z) = \bar{X}\bar{Y}\bar{Z} + \bar{W}XZ + W\bar{X} + WY$$

Logic that defies SOP simplification

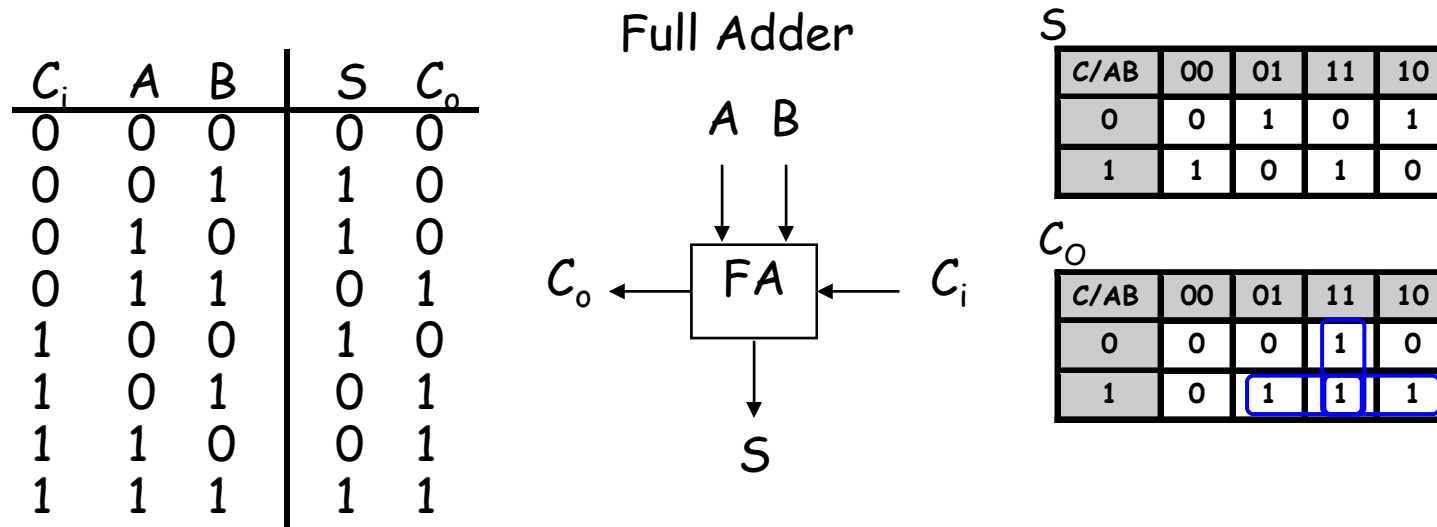

$$S = \bar{A} \cdot B \cdot \bar{C} + A \cdot \bar{B} \cdot \bar{C} + \bar{A} \cdot \bar{B} \cdot C + A \cdot B \cdot C = A \oplus B \oplus C_i$$

$$C_o = A \cdot C + B \cdot C + A \cdot B$$

The sum S doesn't have a simple sum-of-products implementation even though it can be implemented using only two 2-input XOR gates.

Logic Synthesis Using MUXes

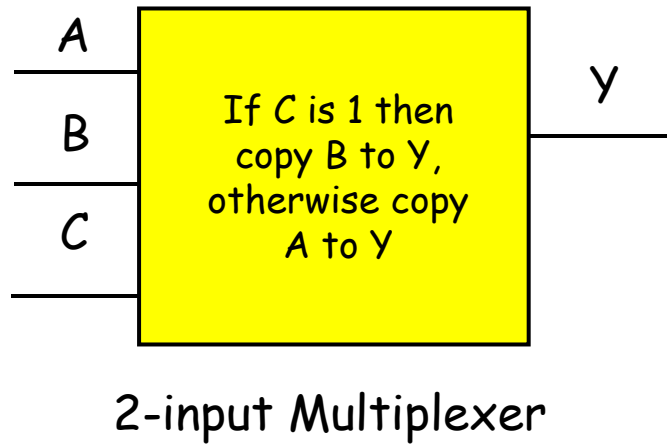

Truth Table

C	B	A	Y
0	0	0	0
0	0	1	1
0	1	0	0
0	1	1	1
1	0	0	0
1	0	1	0
1	1	0	1
1	1	1	1

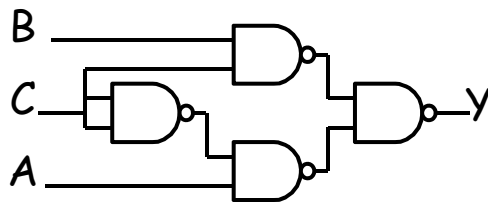

schematic

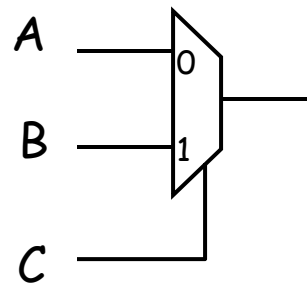

Gate symbol

A 4-input Mux implemented as a tree

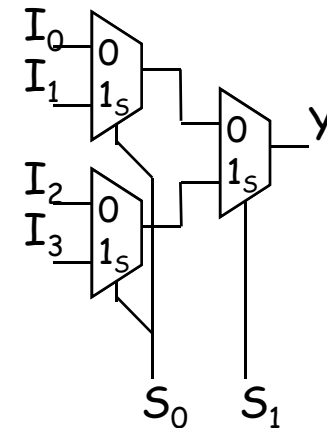

Systematic Implementation of Combinational Logic

Consider implementation of some arbitrary Boolean function, $F(A,B)$

... using a MULTIPLEXER as the only circuit element:

A	B	C	Y
0	0	0	0
0	0	1	0
0	1	0	0
0	1	1	1
1	0	0	0
1	0	1	1
1	1	0	1
1	1	1	1

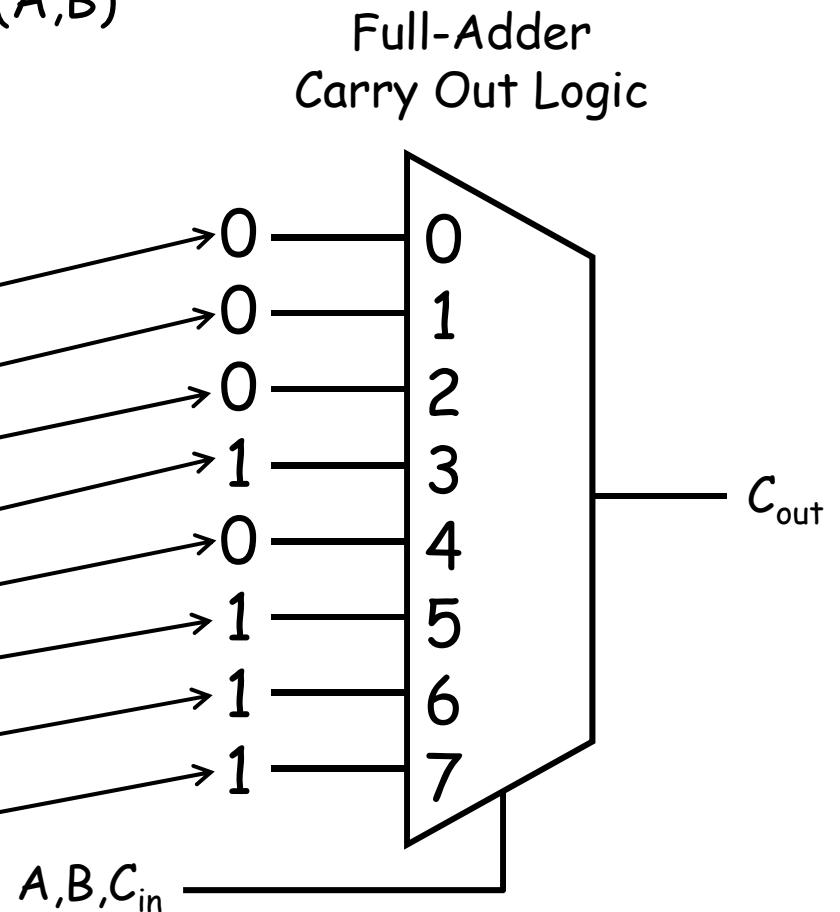

Systematic Implementation of Combinational Logic

Same function as on previous slide, but this time let's use a 4-input mux

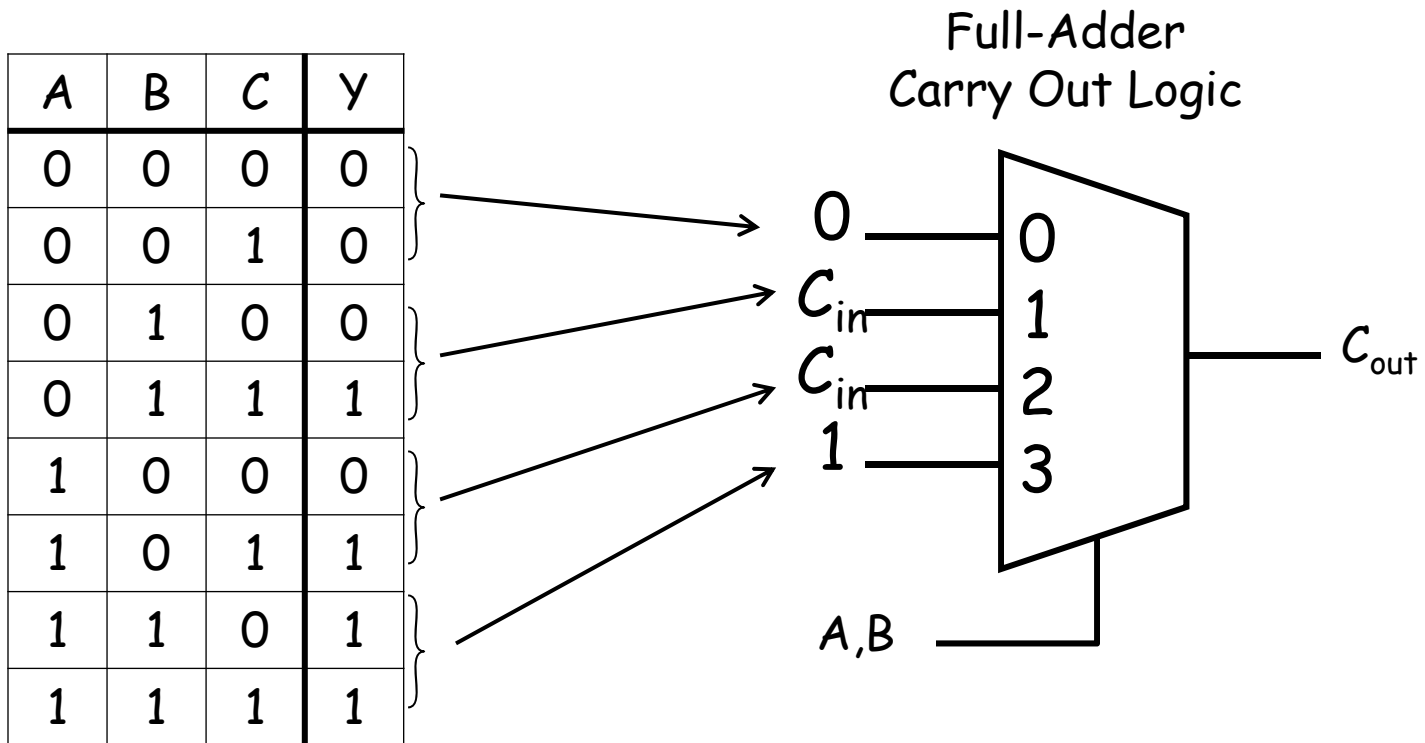

Xilinx Virtex II FPGA

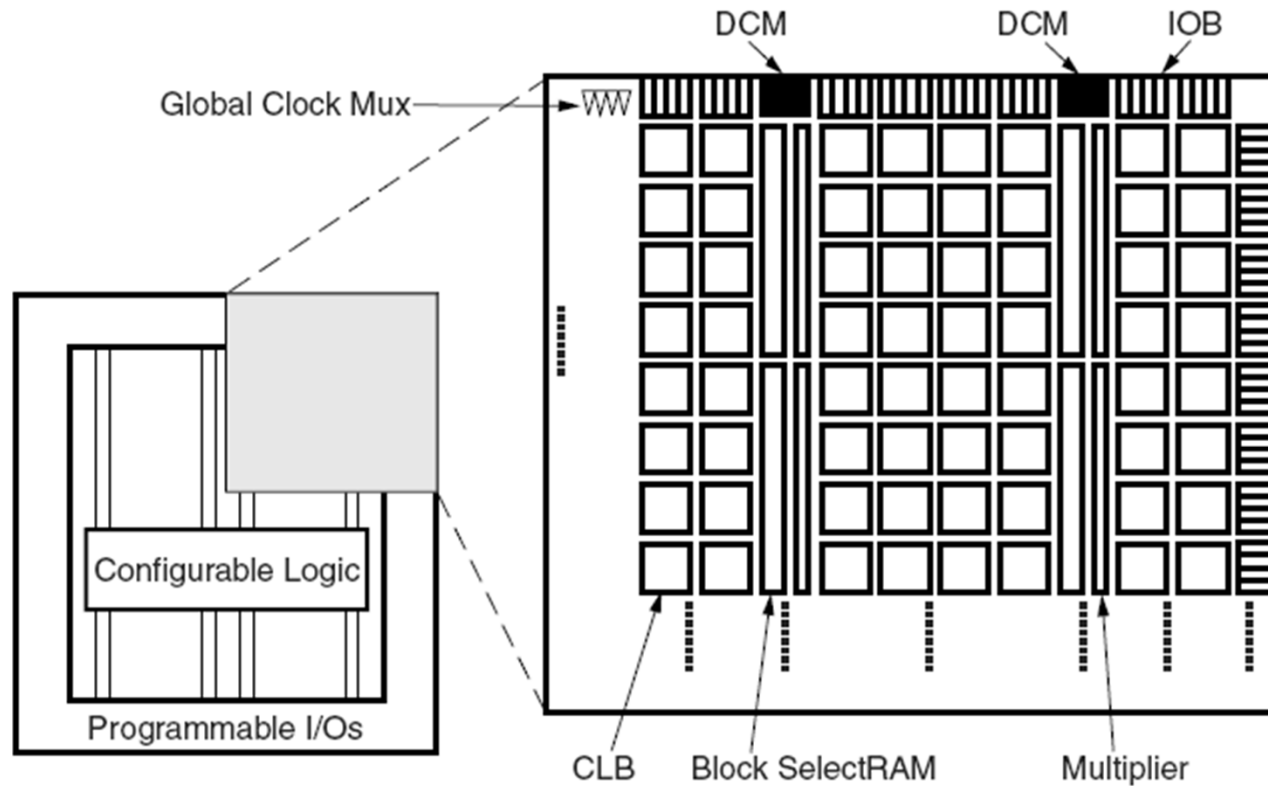

Virtex-II Architecture Overview

XC2V6000:

- 957 pins, 684 IOBs
- CLB array: 88 cols x 96/col = 8448 CLBs
- 18Kbit BRAMs = 6 cols x 24/col = 144 BRAMs = 2.5Mbits
- 18x18 multipliers = 6 cols x 24/col = 144 multipliers

Virtex II CLB

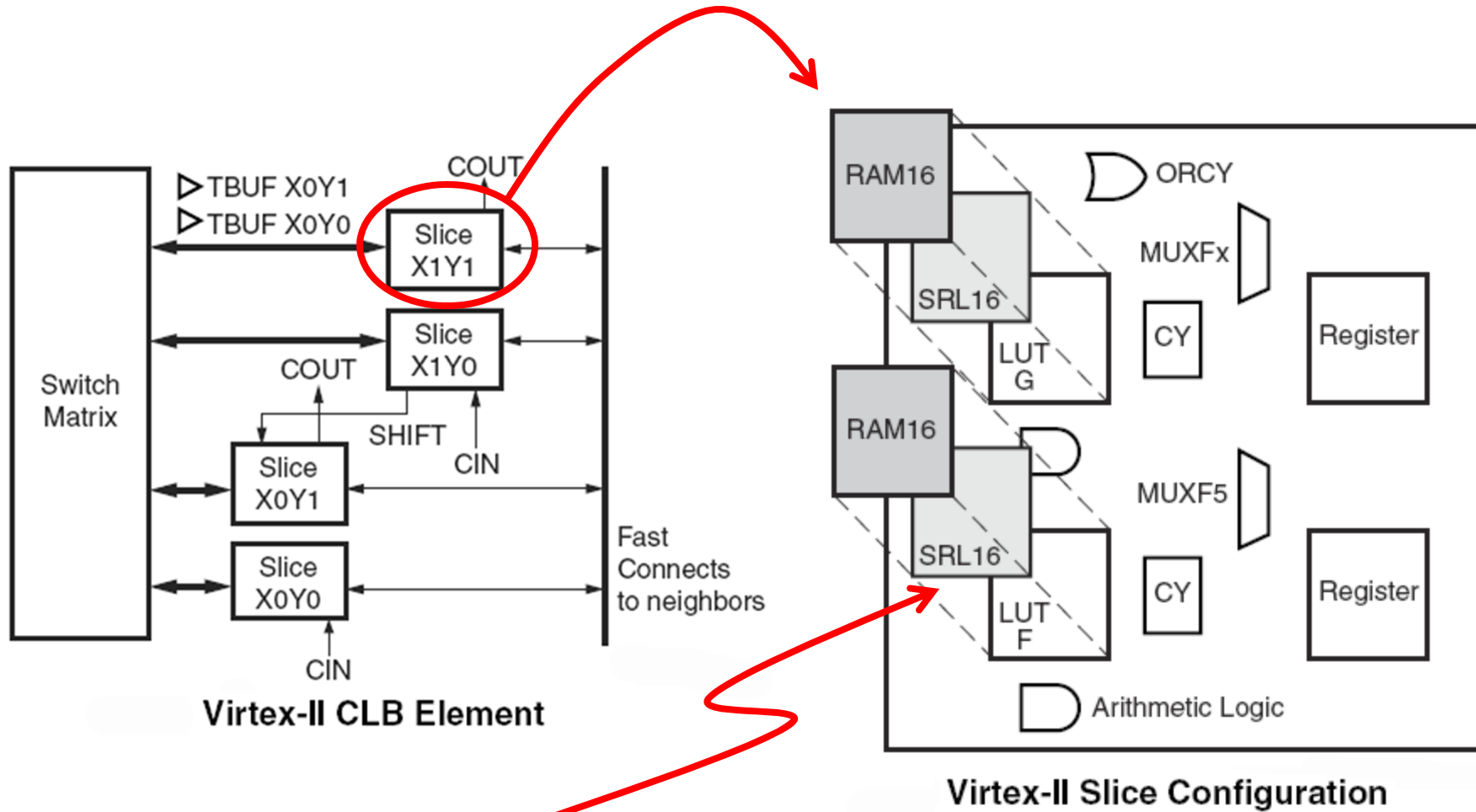

16 bits of RAM which can be configured as a 16x1 single- or dual-port RAM, a 16-bit shift register, or a 16-location lookup table

Figures from Xilinx Virtex II datasheet

Virtex II Slice Schematic

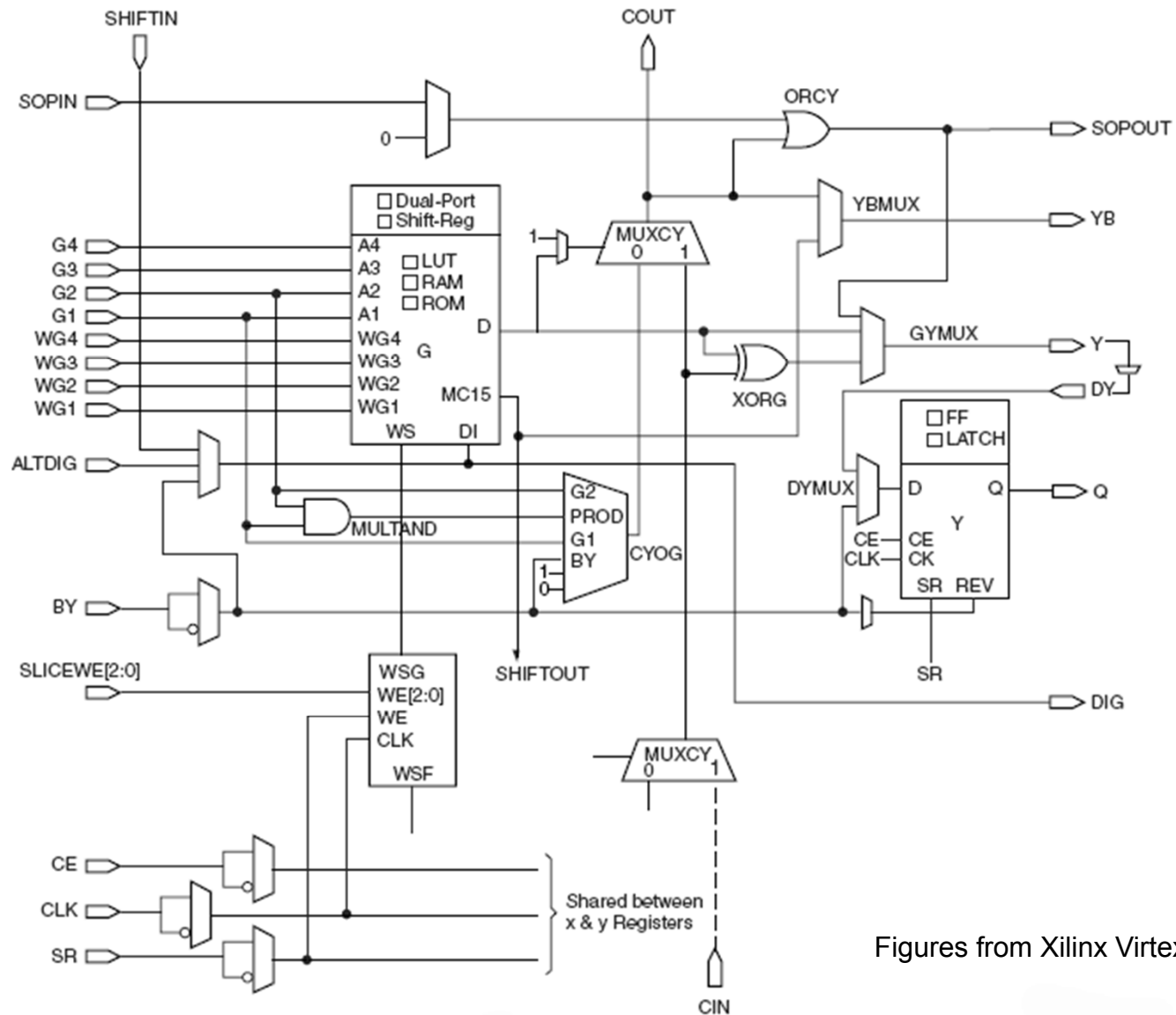

Figures from Xilinx Virtex II datasheet

Virtex-II Slice (Top Half)

Virtex II Sum-of-products

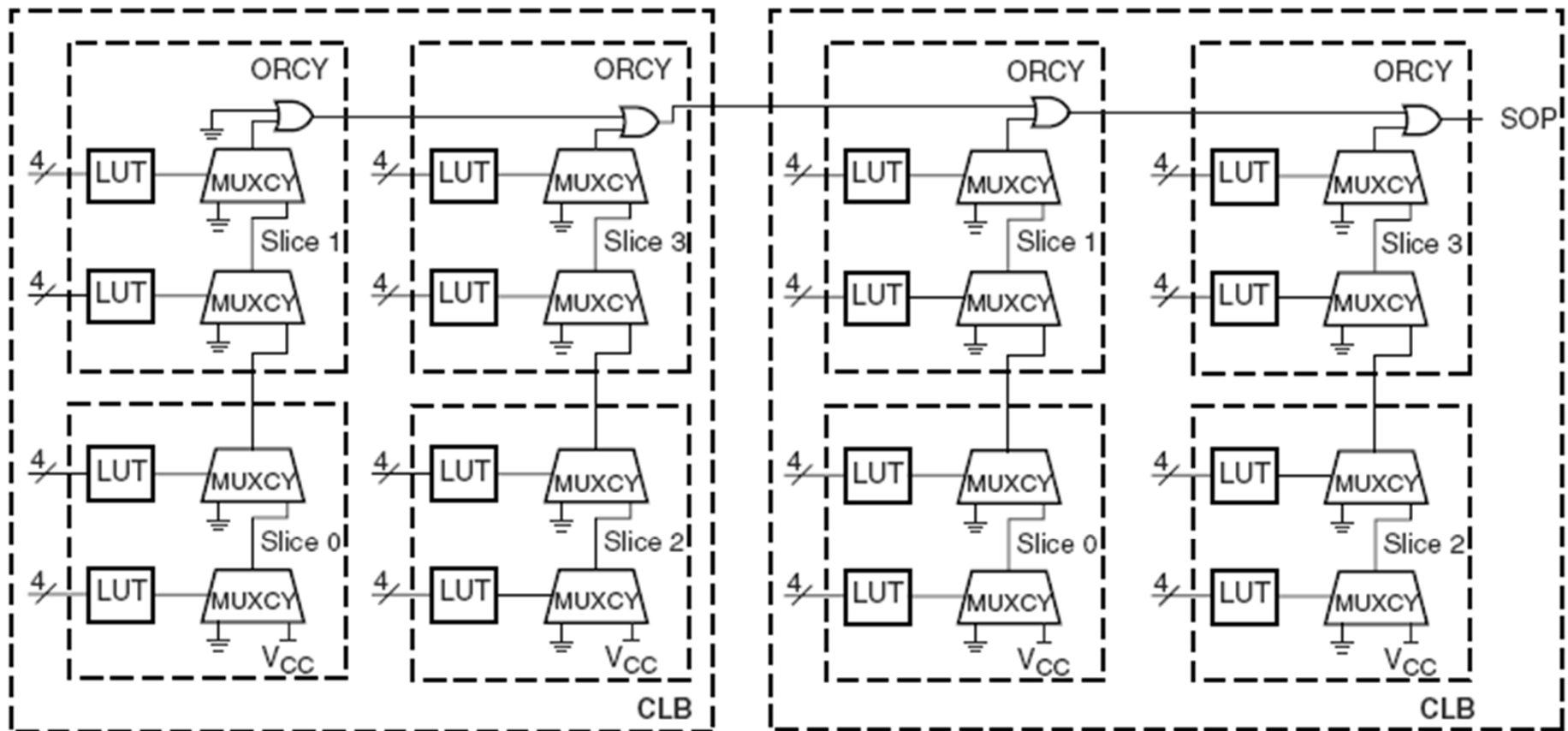

Horizontal Cascade Chain

Figures from Xilinx Virtex II datasheet

Spartan 6 FPGA

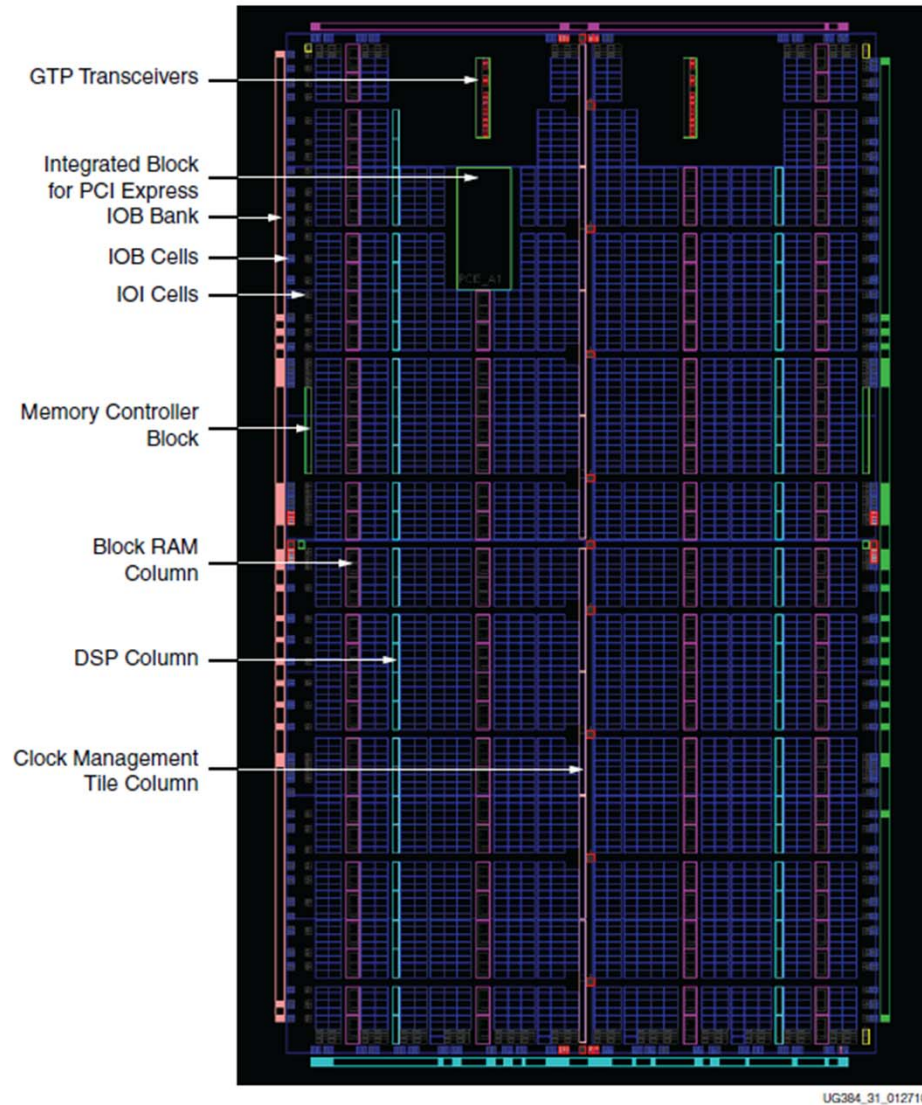
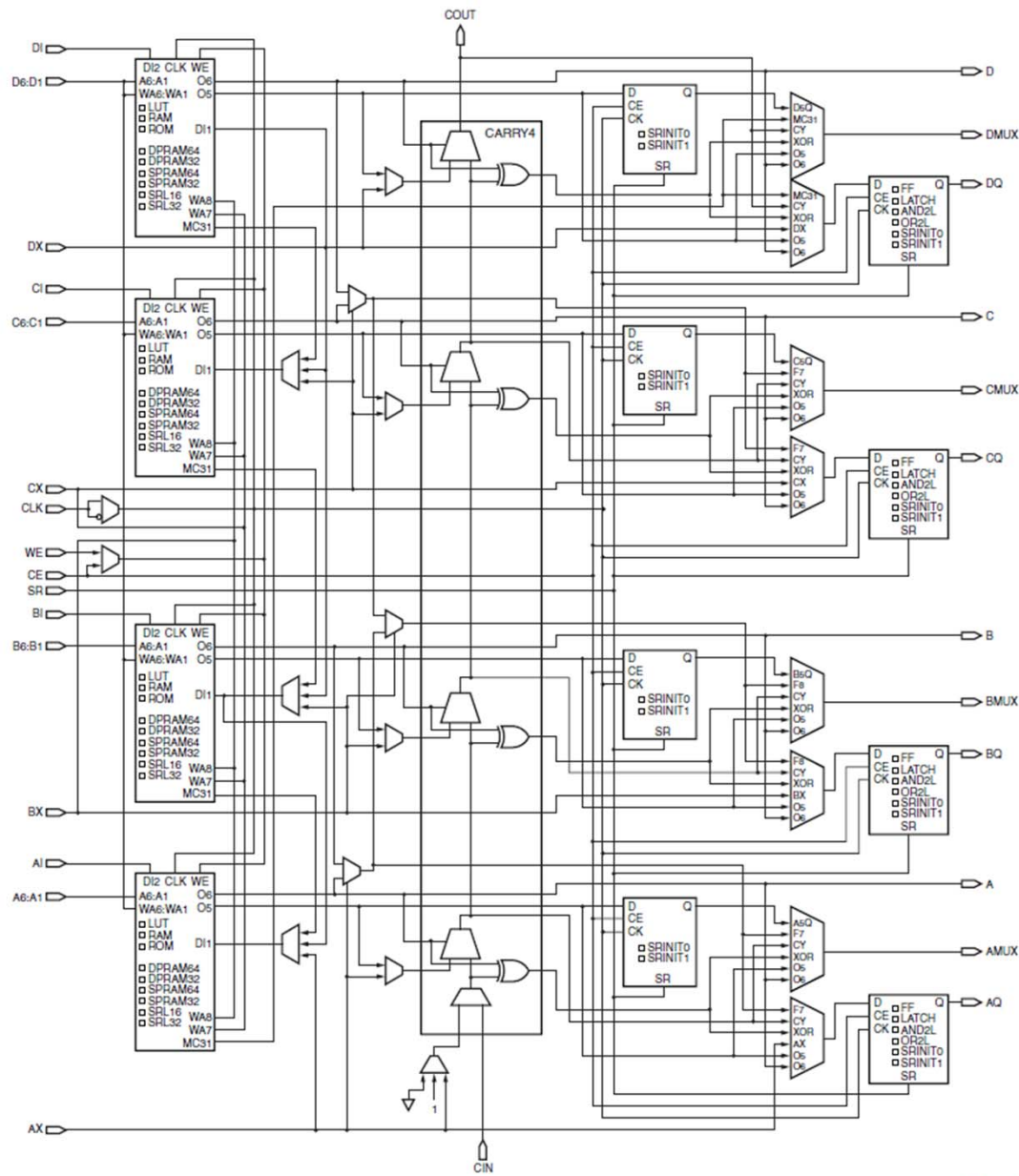

Figure 31: XC6SLX45T Floorplan View in PlanAhead

Spartan 6 SliceM Schematic



Figures from Xilinx
Spartan 6 CLB datasheet

vg384_03_042309

Oscilloscope

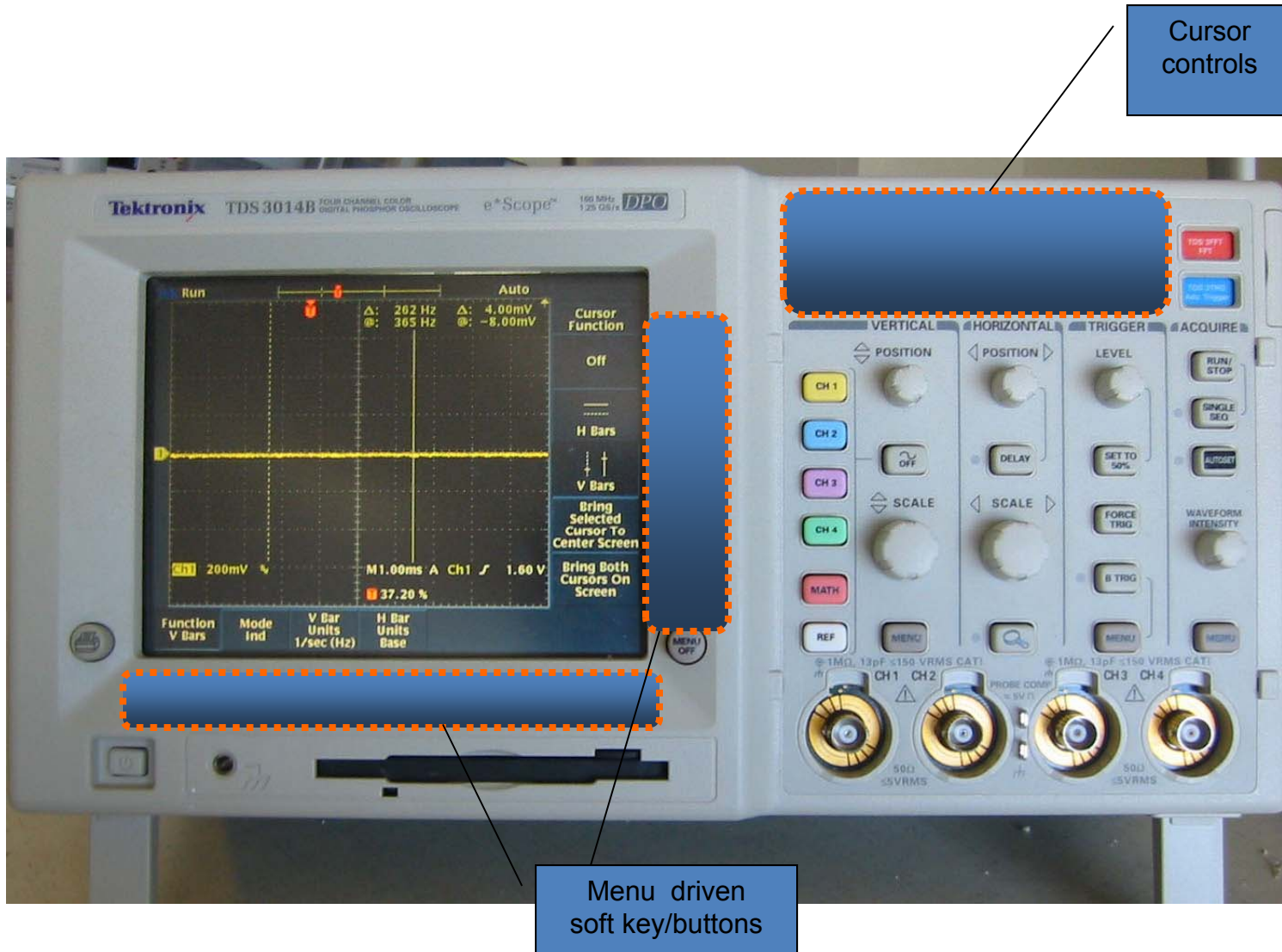

Oscilloscope Controls

- Auto Set, soft menu keys
- Trigger
 - channel,
 - slope,
 - Level
- Input
 - AC, DC coupling,
 - 10x probe,
 - 1khz calibration source,
 - probe calibration,
 - bandwidth filter
- Signal measurement
 - time,
 - frequency,
 - voltage
 - cursors
 - single sweep
- Image capture

Gesture Controlled Drone

Fall 2014



- Track hands with a camera and determine x,y coordinates
- Based on movement of the coordinates, recognize gestures.
- Generate real time digital signals and convert to analog format for transmission to drone - controlling pitch, roll, hover
- Innovation: using hand motion and recognition of gestures to control flight

