

Student Name _____ Date _____

MASSACHUSETTS INSTITUTE OF TECHNOLOGY
Department of Electrical Engineering and Computer Science

6.161 Modern Optics Project Laboratory

Laboratory Exercise No. 1

Fall 2009

Safety, Polarization States of Optical Waves, Dielectric Reflection and Geometric Optics

The Pre-Lab Exercises and the Pre-Lab questions for each In-Lab experiment must be completed BEFORE entering the Lab. In your lab notebook record data, explain phenomena you observe, and answer the questions asked. Remember to answer all questions in your lab notebook in a neat and orderly fashion. No data are to be taken on these laboratory sheets. Tables provided herein are simply examples of how to record data into your laboratory notebooks. Expect the in-lab portion of this exercise to take about 3 hours. **Also note that instead of a formal written report, your report for this Laboratory Exercise will be presented in oral fashion before the TA and the Writing Coordinator. Detailed instructions for the presentation will be given later.**

PRE-LAB EXERCISES

PL1.1 - Safety

Read the entire Laboratory and laser Safety Packet that was handed out in Lab 0. Be prepared to answer questions about high-voltage and laser safety before arriving at the MOL.

PL1.2 – – Get Prepared to Start the Laboratory Exercises

Read the **entire** laboratory handout, and be prepared to answer questions before, during and after the lab session. Determine all the equations and constants that may be needed in order to perform all the laboratory exercises. **Write** them all down in your laboratory notebook before entering the Lab. This will ensure that you take all necessary data while in the Lab in order to complete the lab write-up. This preparatory work will also count toward your Lab Exercise grade.

PL1.3 – Telescope Design

For this exercise, you are encouraged to work in groups of 2-3 people.

In this exercise, you are to design a telescope given the optical components listed in Table I. Your telescope must be a refractor (lenses-only). The entire telescope assembly must not be any longer than the 2 feet (the shorter, the better). Your telescope will need to contain **at least** 2 optical elements, but no more than 4. The telescope must be a terrestrial telescope (meaning that the image as seen by a viewer must be erect). Your total system magnification must be at least 4x and at most 40x at an imaging distance of either 15 meters or adjusted to infinity (a collimating telescope – this is the most common form of telescope, and is preferred for simplicity and robustness of design).

Be sure to use the ABCD matrix approach to simplify the design of your telescope. You should include all of your system specifications in the pre-lab write-up – including any computer code, hand-calculations or other materials used in the design. Be sure to specify the focal lengths, total system magnification as well as the locations of the lenses, the object and the image. Remember, there is no one ‘correct’ way to design your telescope. The Lab staff will be very sad if everyone designs the same telescope. Additional points will be awarded for ingenuity and thoughtfulness in design. Also, be sure not to use too many elements; each additional element in your system will lead to decreased contrast and decreased resolution. “Ingenuity and thoughtfulness” means designing smart, and minimizing complexity.

TABLE I. Optical elements available for building your telescope:

Size	Type	Focal Length	Quantity
2"	Bi-Convex	200mm	1
2"	Bi-Convex	100mm	2
2"	Bi-Convex	75mm	1
1"	Bi-Convex	200 mm	1
1"	Bi-Convex	150 mm	1
1"	Bi-Convex	100 mm	1
1"	Bi-Convex	75 mm	1
1"	Bi-Convex	50 mm	1
1"	Bi-Convex	35 mm	2
1"	Bi-Convex	25.4 mm	2
1"	Bi-Concave	-100mm	1
1"	Bi-Concave	-75mm	1
1"	Bi-Concave	-50mm	1
1"	Bi-Concave	-25mm	1

Hints: Remember to use larger lenses at the input of your system (the side facing the world), and smaller lenses close to the eye. Also, before you start designing, determine which element in the ABCD matrix must equal zero for angular magnification to occur.

PL1.3 Extra Credit (not required): Design a zoom-optic system with the components listed above. (With a zoom-optic system, you can adjust the magnification of your telescope by moving a central lens while keeping the outer most lenses at *approximately* the same location – basically the same setup as is used in an SLR camera zoom lens.)

“Two brothers bought a cattle ranch and named it "Focus." When their father asked why they chose that name, they replied: "It's the place where the sons raise meat."

-- Prof. W. B. Pietenpol, Physics Department, University of Colorado,
Boulder, Colorado

LAB EXERCISES

1.1 Linear Polarizer

Pre-Lab Question

Explain using electric dipole arguments and with the aid of diagrams why the light reflected from the floor wax is predominantly polarized perpendicular to the plane of incidence.

In-Lab Assignment

As was discussed in lecture, light reflected off the waxed floor tiles is predominantly polarized perpendicular to the plane of incidence. Holding the given sheet of linear polarizer close to your eye, use such reflections to determine the axis of the polarizer. Convince the T.A. that you have identified the polarizer axis.

T.A. or L.A.
Signature

1.2 Two-Polarizer Diagnostic System

The setup you are given consists of a randomly polarized (unpolarized) laser beam of intensity I_0 , a pair of polarizers, and a screen arranged as illustrated in Figure 1. The second polarizer is often called an analyzer. Its axis is generally oriented perpendicular (crossed) or parallel to the axis of the first polarizer.

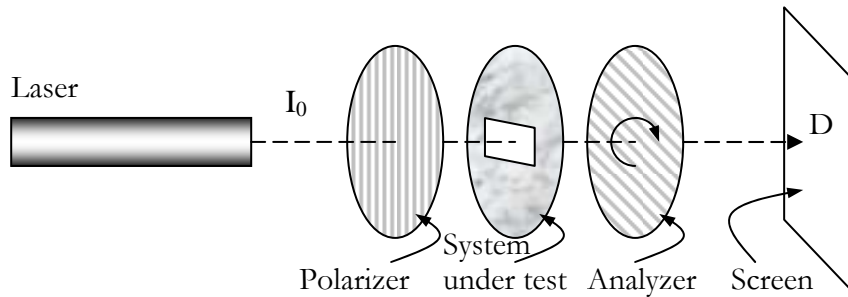

Figure 1 – Diagnostic two-polarizer system

In-lab Assignment

With the first and second polarizers crossed in the above system, place a third sheet of linear polarizer in the system between the two stationary crossed sheets and observe the intensity of the transmitted light on the screen as you rotate the third polarizer. Make sure to record the orientation of every element in the diagnostic system in your lab notebook.

Now place a photodetector at D and record below the intensity on the screen as a function of the angle of rotation of the third polarizer. About 10 points between (and including) two adjacent intensity maxima should be sufficient. Record this chart into your lab notebook.

Angle	Relative Intensity

Post-lab Questions

- Explain why the intensity on the screen changes as the central polarizer is rotated?
- Derive the form of the theoretically expected intensity at the detector, and compare it with your measurement (you may use Jones matrices for this, or use basic trigonometry). Explain the discrepancy, if any.

1.3 Quarter and Half Wave Plates

In-Lab Assignment

- (a) You are given one quarter-wave plate and one half-wave plate (labeled A and B) but it is not known which plate is which. Use the system in Figure 1 to: (i) find the axes of the quarter-wave plate, (ii) find the axes of the half-wave plate, and (iii) distinguish one plate from the other. Convince the T.A. that you have indeed found the axes and distinguished the two wave plates.

T.A. or L.A.
Signature

Describe the experiments you performed on the two wave plates. Tabulate the results, and explain how you arrived at your conclusions. Make sure to record the orientation of every element in the diagnostic system in your lab notebooks.

Post-lab Questions

A half-wave plate can be used to convert vertically polarized light into horizontally polarized light, and vice versa. Another useful application of a half-wave plate is as a linear polarization rotator. Indeed, if linear polarized light is incident at normal incidence on a half-wave plate and the plate is rotated through an angle θ about an axis parallel with the propagation direction, the polarization of the transmitted beam is rotate by 2θ .

- (a) In your lab notebook, draw diagrams and explain how a half-wave plate converts vertically polarized light to horizontally polarized light,
- (b) In your lab notebook, draw diagrams and explain how and why a half-wave plate achieves polarization rotation.

Note: We are not looking for detailed calculations, but instead a detailed written description using diagrams as visual aids.

1.4 Magic Sheet

In-Lab Assignment

You are given a sheet of "magic" material, which transmits light when folded in one direction, but blocks light when folded in the other direction. Observe this for yourself. Using only linear polarizers, devise nondestructive experiments to determine the possible optical elements that constitute the "magic" material. Record your data in tabular form in your lab notebook, and explain with the help of diagrams why light is blocked or passed in each experiment you perform. Show clearly how you arrive at your conclusion about the magic material.

1.5 Dielectric Reflection and the Brewster Angle

In-Lab Assignment

The Brewster angle is defined as the angle of incidence for which the reflected light intensity from a dielectric boundary goes to zero for TM polarization. This effect can be demonstrated by the experiment shown schematically below.

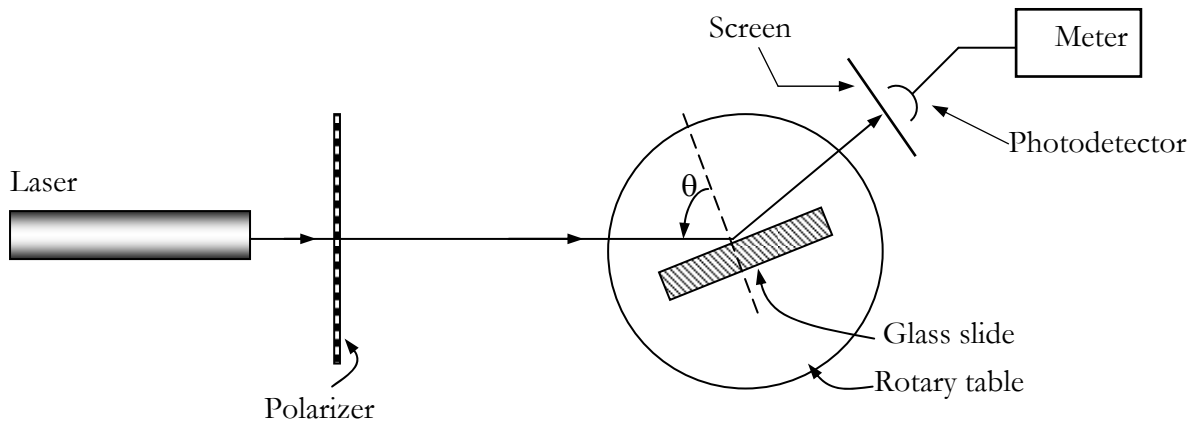

Figure 2. - Experimental setup to demonstrate Brewster's angle.

Use a randomly polarized laser beam for this experiment. Align the glass slide so that its axis of rotation is perpendicular to the laser beam. This can be accomplished by adjusting the laser or the glass slide so that at normal incidence, the reflected beam goes back close to or into the laser cavity.

- (a) Where is the plane of incidence in your experiment?
- (b) With the linear polarizer aligned with its axis horizontal, and the laser beam centered on the axis of rotation of the glass slide, rotate the glass slide and observe the intensity of the reflected beam on the screen. Rotate the polarizer sheet by 90° and repeat the experiment. Copy the table below into your lab notebook. Record your observations of the **reflected beam** for each of the two polarization cases in your lab notebook.

	Horizontal Polarization		Vertical Polarization	
Polarization in plane of incidence?	<input type="checkbox"/> Yes	<input type="checkbox"/> No	<input type="checkbox"/> Yes	<input type="checkbox"/> No
Does its intensity ever vanish?	<input type="checkbox"/> Yes	<input type="checkbox"/> No	<input type="checkbox"/> Yes	<input type="checkbox"/> No
If yes, corresponding angle of incidence	_____		_____	

- (c) Now, use the photodetector to measure the reflectivity of the glass slide as a function of the angle of incidence for both polarizations. About every 5° is good enough (the most accurate measurements are obtained if measurements for both polarizations are made before the angle of incidence is changed). Record the raw data in your lab notebook in a similar fashion to the

1.6 Total Internal Reflection System

You are given a 45°-right-angle glass prism on a rotary table and a HeNe laser set up in the arrangement shown in the Figure 3. Illuminate one of the small faces with the laser beam at normal incidence (reflection off this surface goes back into the laser cavity) and observe the phenomenon of total internal reflection.

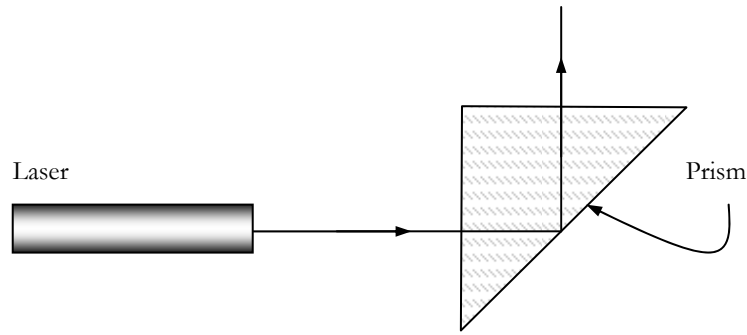

Figure 3 – Setup for observing total internal reflection using 45° - right angle prism.

Pre-Lab Questions

- On a sketch of Figure 4, indicate which direction you would have to rotate the prism to get light transmitted through the hypotenuse.
- Derive an expression relating the index of refraction and the rotation angle at which you should first observe light transmitted through the hypotenuse.

In-Lab Assignment

- Sketch the actual system used for this experiment.

Illuminate one of the small faces with the laser beam at normal incidence (reflection off this surface goes back into the laser cavity) and observe the phenomenon of total internal reflection. Slowly rotate the prism until the transmitted beam just grazes the hypotenuse of the prism.

- Measure the angle of rotation, and use it to calculate the refractive index of the glass block. You should have come up with an equation to do this in the pre-lab exercises. Use your derived equation, while in the Lab to perform a reality check on the index of refraction.

1.7 Imaging Properties of a Convex Lens

In this exercise, we will explore the imaging properties of a simple symmetric biconvex lens. The setup we will use is shown in Figure 4. It consists of a white light source, a transmission object (slide), a biconvex lens, and a screen, all mounted along an optical rail.

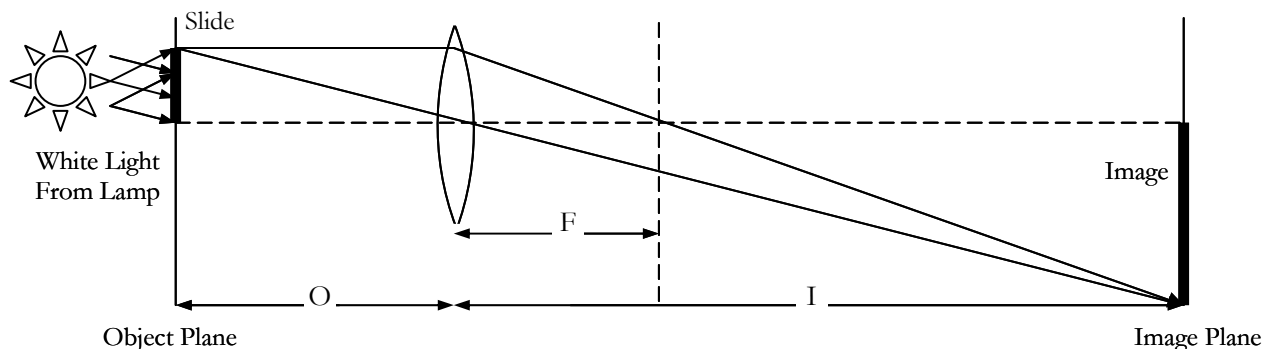

Figure 4. - Setup to explore the imaging properties of a convex lens.

In-Lab Assignment

Using the setup in Figure 4, and keeping the light source (slide) and object (lamp) fixed, select five different object distances, O , (distance from the lens to the object) by moving the lens. For each object distance, measure: (1) the corresponding image distance, I , for sharply defined image on the screen, and (2) the size of the image.

Post-Lab Questions

- Make a plot of $1/I$ versus $1/O$ and from your plot determine the focal length of the lens (use all your data points – if you are not sure how to fit the data, please ask). Include the raw data, the plot and your calculation of the focal length in your report.
- If the refractive index of the lens is 1.52, what is the radius of curvature of its convex surfaces?
- Why is a sharp image not seen when the object distance is less than the focal length of the lens?
- If two lenses of focal length F_1 and F_2 are abutted, what is the focal length of the combination? Show your calculation.
- How would you go about measuring the focal length of a biconcave lens?

1.8 Telescope Fabrication (optional - for extra credit)

Build the telescope you designed in the pre-lab exercise. Comment on the performance of your telescope. Did your telescope operate as you expected? Why or why not? Explain the operation of your telescope to the TA.

T.A. or L.A.
Signature

Congratulations, you have finished Laboratory #1. Please write down in your notebook how long it took (start to finish) to complete: (a) the pre-lab work, (b) the in-lab portion, and (c) the post-lab writeup.