

Student Name _____ Date _____

MASSACHUSETTS INSTITUTE OF TECHNOLOGY
Department of Electrical Engineering and Computer Science

6.161 Modern Optics Project Laboratory

Laboratory Exercise No. 2

Coherence and Interferometry

Fall 2011

To get the most out of your in-lab experience, you must come to Lab prepared (makes life easier for you and the TA and minimizes your time in the Lab). Thus, you should go through this Lab manual, complete the Pre-Lab Exercises, and answer all the Pre-Lab questions BEFORE entering the Laboratory. In your lab notebook record data, explain phenomena you observe, and answer the questions asked. Remember to answer all questions in your lab notebook in a neat and orderly fashion. No data are to be taken on these laboratory sheets. Tables provided herein are simply examples of how to record data into your laboratory notebooks. Expect the in-lab portion of this exercise to take about 3 hours. **Please note that a formal written report is required for this Laboratory Exercise. The CIM grading rubric is given in the Appendix.**

PRE-LAB EXERCISES

PL2.1 – Getting Prepared to Start the Laboratory Exercises

Read the **entire** laboratory handout, and be prepared to answer questions before, during and after the lab session. Determine all the equations and constants that may be needed in order to perform all the laboratory exercises. **Write** them all down in your laboratory notebook before entering the Lab. This will ensure that you take all necessary data while in the Lab in order to complete the lab write-up. This preparatory work will also count toward your Lab Exercise grade.

PL2.2 Michelson Interferometer Considerations

For this exercise, you are encouraged to work in groups of 2-4 people. On Lab day, you will be asked to build and analyze one of the most commonly used interferometers in science and industry - a Michelson interferometer (see Fig. 1). Michelson interferometers are used in coherence-detection apparatus, like FTIRs (Fourier Transform Infrared Spectroscopy), in countless mechanical systems (to maintain precise alignment), as well as in the space-based Laser Interferometer Gravitational Wave Observatory (LIGO), just to cite a few examples. Michelson interferometers are relatively simple to build, easy to align and have some advantages over alternate interferometer designs. In this pre-lab exercise, you are asked to analyze a Michelson interferometer that will be used to measure the coherence length of a diode laser source. This interferometer has one stationary arm and one with a movable mirror as shown in Fig. 1.

First we would like you to determine the angular accuracy required to perform a ‘rough alignment’ of a Michelson interferometer.

- (a) Using collimated 632.8 nm (wavelength) light, you must determine the angular accuracy needed to form fringes of 1mm spacing on a test plane, given a nominal Michelson interferometer arm length of $l_1 = l_2 = 20$ cm.

- (b) If the movable mirror is gimbaled from a ball bearing on one edge of a one-axis angular-rotation mount which uses a micrometer screw located at a distance $r = 2.5$ cm away at the opposite edge of the mirror, what is the corresponding distance the micrometer must travel to rotate the mirror between the angular alignment calculated above and the state of ‘perfect’ alignment (both output beams perfectly collinear)? Below is a diagram to illustrate the principle of the Michelson interferometer.

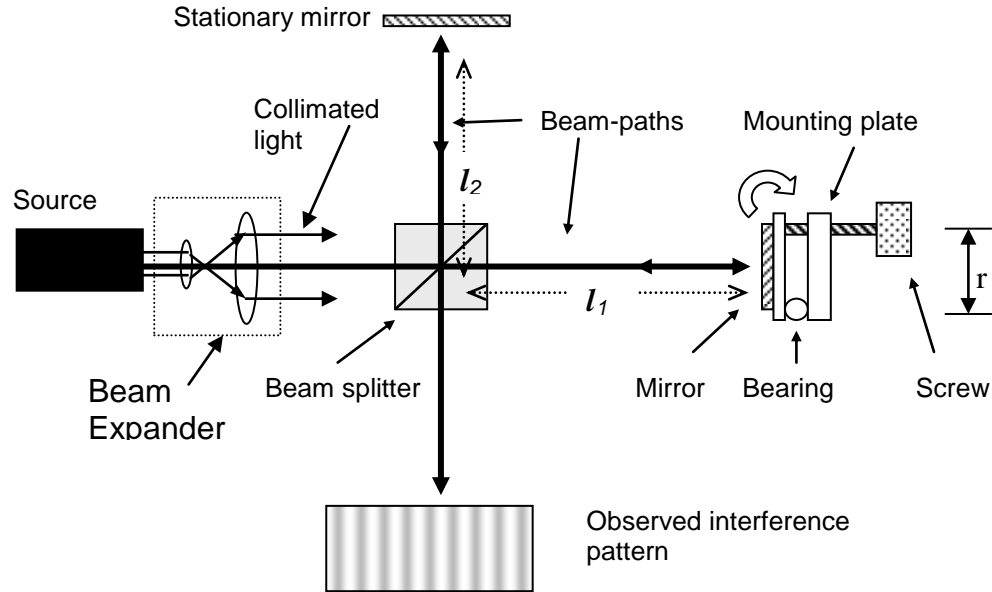

Fig. 1 The Michelson Interferometer

- (c) If the light from the source is divergent (spherical waves instead of plane waves), what would the fringe pattern look like for a ‘perfectly’ aligned Michelson interferometer?
- (d) Although you are not being asked to do a full design of a coherence-detecting Michelson interferometer, you should think about how all of the parts listed in the table below could be used to build one. So please make a drawing in your lab notebook showing how all of the **optical** components listed below could be used to build a coherence-detection Michelson interferometer.

Table of Available Components

Qty	Description
2	1" two-axis mirrors
1	0.5" cube beam splitter
1	25 micron pinhole
2	Variable irises
1	Short focal-length 20x objective
1	Long focal-length biconvex lens (collimating lens)
1	3" linear translation stage w/micrometer
1 set	Posts, post holders and other mounting hardware
1	1'x1' optical breadboard
1	He-Ne laser used for alignment

Communication Intensive Post-Lab Writing Exercise

There are several paradoxes in optics that have been the subject of great disagreement and controversy in the days of Fresnel, Fraunhofer, Arago and others who have made great contributions to the field. This assignment will give you your chance to join the heroes above and leave your stamp forever on the face of 6.161 optics.

For this assignment, consider the scenario in which the standard Michelson interferometer is excited with an on-axis collimated laser beam about 25 mm in diameter (standard laboratory practice). The interferometer is perfectly aligned (no beam walk off) and the physical path length difference of its two arms is exactly $\frac{1}{4}$ wavelength. According to standard electromagnetic wave theory, there will be complete destructive interference, and hence no output beam. But power left the laser and entered the interferometer. Since power does not show up the output beam what happened to it? Is this system violating the conservation of energy?

In your discussion (roughly one or two type-written pages) explaining this phenomenon, make your arguments as clearly as you can. Use illustrations to help clarify your reasoning. Assume your audience is an MIT Freshman. The writing coordinator will be looking at your grammar, at your sentence construction, and to see how clearly you can write. The TA and the Lecturer can get excited by arguments that may be flawed because of unfounded or unreasonable assumptions, but for the most part may be convincing. We are looking for critical thinking on your part and for how well you can express your ideas.

“The strongest arguments prove nothing so long as the conclusions are not verified by experience. Experimental science is the queen of sciences and the goal of all speculation.”

-- Roger Bacon (1214-1294) English philosopher, scientist, optical experimentalist

2.0 IN-LAB EXERCISES

2.1 Mach-Zehnder Interferometer

You should find the Mach-Zehnder interferometer already set up and aligned. The instrument should be adjusted such that a uniform intensity pattern is produced on the screen (essentially no fringes). Make sure that the input He-Ne laser beam is well collimated by measuring the dimensions of the auxiliary output beam near the instrument and several meters away (the beam diameter should be roughly the same at both positions).

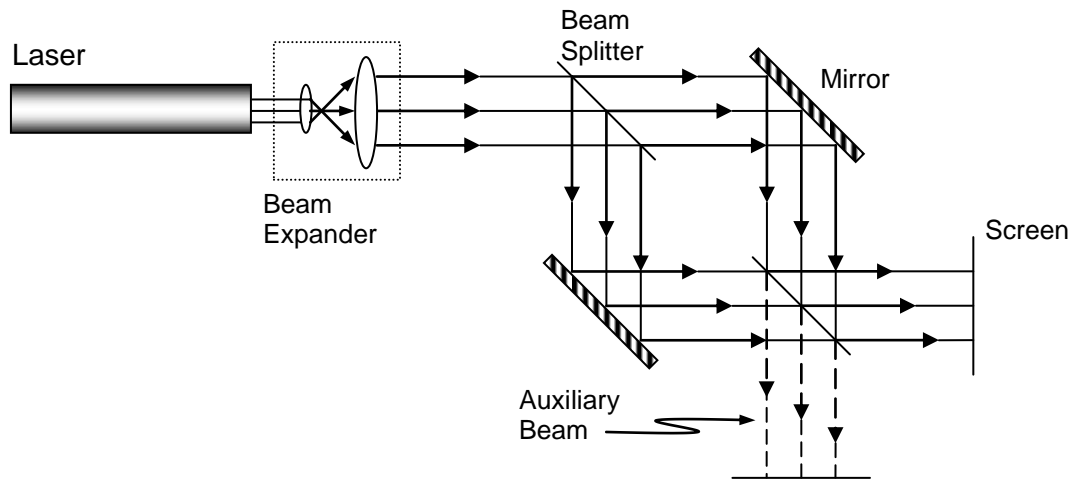

Fig. 2. The Mach-Zehnder Interferometer

For this exercise, we will work with a glass slide (about 2 mm thick) that has negligible curvature, and therefore we shall approximate the surfaces of the slide as planar, but non-parallel. The slide, therefore, has the shape of a wedge as illustrated in Figure 3 (b). Now, insert the given microscope slide into the mount, and place the mount in one of the arms of the interferometer.

- In your notebook, make a sketch of the fringes on the screen, measure the spacing between the dark fringes and label your sketch with the distances (spacings) you measured.
- By now you should have observed that the two output beams of the Mach-Zehnder interferometer are complementary. Why?

Post-Lab Exercise

- Use your data from (a) to calculate the parallelism of the glass slide. That is, determine the angle θ between the surfaces of the wedge (the wavelength of the He-Ne laser light is 632.8 nm).
- Explain with the aid of Figure 2 and your knowledge of phase changes on reflection from surfaces why the two output beams of the Mach-Zehnder interferometer are complementary.

2.2 Flatness Measurements

Normally, we think of a glass slide as a thin slab with boundaries defined by two perfectly parallel planes. Of course, in reality this is not the case. The glass-air boundaries may be curved, undulating, or planar, and in general are not parallel. Curvature may be in one or many directions as illustrated in Figs. 3 (a) and 3 (b).

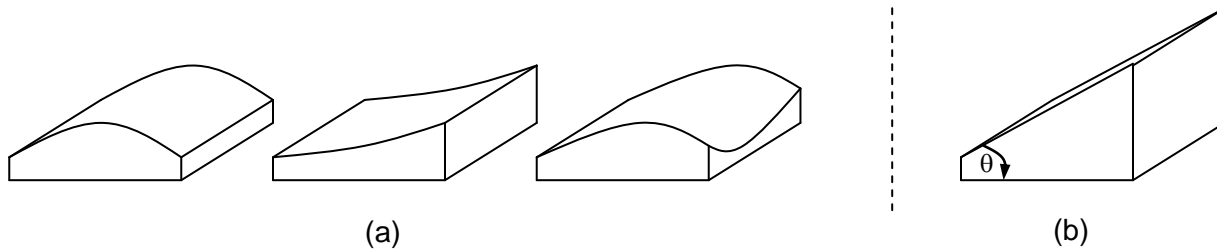

Fig. 3. (a) Possible shapes of curved glass slides; (b) A wedged glass slide

The goal of this experiment is to qualitatively determine the surface flatness of a number of glass-slide samples. The equipment to be used includes a sodium vapor lamp (quasi-monochromatic source), a reference flat (glass block with a reference surface of known flatness), lens paper, and the samples to be studied. The setup is as illustrated in Fig. 4.

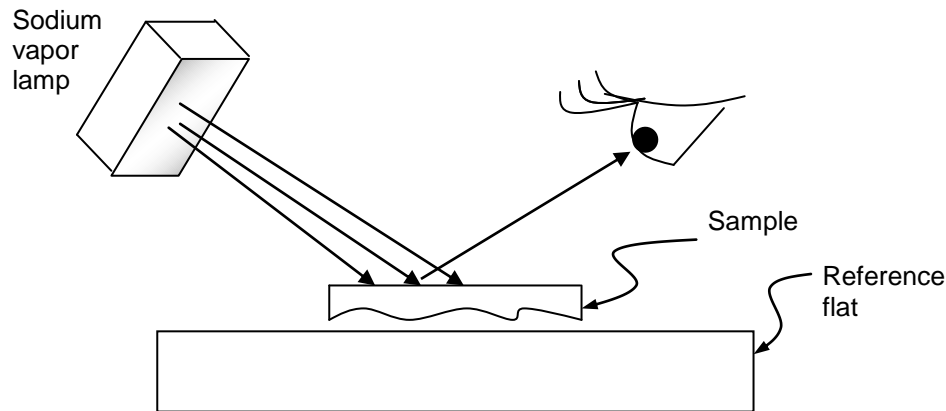

Figure 4. Setup for measuring the flatness of glass blocks and plates

Place the surface of the sample to be measured against the reference flat and illuminate the assembly with the sodium lamp. You should observe a distinct set of fringes, which illustrate the relative flatness of the surface of the sample, assuming the reference flat is perfectly flat. Dust and other foreign particles between the two surfaces will lead to a wedge of air between the sample and the flat and to a fine fringe pattern that will be difficult to interpret. If this occurs, place a sheet of clean lens paper between the two surfaces and slowly drag the lens paper out from between the surfaces. This should remove most of the loose dust particles. Slowly rotate the sample back and forth until the widest possible spacing between the fringes is obtained.

For (a) the plexiglass triangular block (b) the rectangular glass block, (c) the wedged glass block, and (d) the thick circular glass disc:

- (1) Sketch and describe in your notebook the fringes you get for each of the four samples.
- (2) Interpret the fringes in the context of the flatness of the surfaces by drawing pictures in your notebook of the surface profiles, and
- (3) Rank the four samples in increasing order of flatness.

2.3 Parallelism Measurements

Several numbered thin cover glass slides (about a dozen) are provided. A simple qualitative method of quickly establishing parallelism of the glass slides involves the examination of Haidinger fringes as described next. Place several of the thin glass slides on the clean sheet of paper, which lies on the small low table. Stand upright over the glass slides with the sodium light next to your forehead and illuminate the glass slides so that interference patterns are observed for each glass side. By comparing the interference patterns (Haidinger fringes) identify: (a) the most plane parallel, and (b) the least plane parallel glass slide. Write the numbers of the two slides in your notebook (as shown below). Explain to the TA how you arrived at your choice and have the TA sign your notebook.

T.A. or L.A.
Signature

Most parallel Least parallel

Pre-Lab Assignment

- (a) Explain how Haidinger fringes are formed.
- (b) What should the Haidinger fringe pattern look like for a perfectly parallel glass slide?

2.4 Multiple Beam Interferometry with a Thin Glass Plate

In this experiment, we will attempt to observe the gross features of multiple-beam interference as described theoretically in the notes. The setup to be used is shown in Fig. 5. It consists of a thin glass plate (Corning #1 cover glass slide, about 150 μm thick) that is mounted on a rotary table such that the axis of rotation passes through the front surface of the plate. The plate is illuminated with a He-Ne laser beam ($\lambda = 0.6328 \mu\text{m}$) that is focused on the front surface of the plate at a point on the axis of rotation. The goal here is to excite a small region (about 1 mm) of the plate with several angles of incidence simultaneously so that a interference fringes can be seen (rather than a single reflected and transmitted spots – although the experiment can be done this way as well). A small region of excitation is used to assure that the plate thickness is relatively constant in the excited region. Two screens are used to view the reflected and transmitted interference patterns.

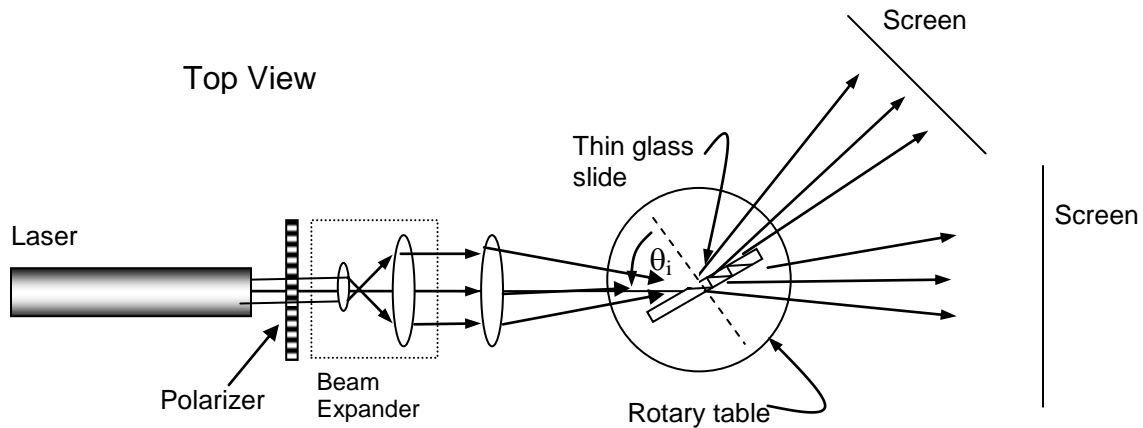

Fig. 5. Setup for observing multiple beam interference from a thin glass slide

You should vary the external angles of incidence, θ_i , by rotating the glass slide using the rotary table, and observing the interference patterns on the screens. Note that the range of θ_i (the internal angle) is limited from 0 to θ_c , the critical angle. Unfortunately, varying θ_i causes both δ (the path difference between successive emerging beams) and R , the surface reflectivity, to change at the same time. However, in this experiment it is still possible to observe the effect of varying R on the sharpness (separation/width) of the fringes. Varying δ simply brings maxima and minima of different orders into view in the reflected light; these may be spaced closer or farther apart in angle depending on the value of θ_i .

Specifically, you should observe that for small values of θ_i , R is small, and so the finesse, \mathcal{F} , is low -- hence, the ratio of the fringe width to the fringe separation is relatively small (the dark fringes appear fuzzy at their edges). However, as θ_i increases, R increases and, therefore, the finesse and the fringe contrast and fringe sharpness (sharp edges) increases. That is, the general tendency is an increase in reflectance (reduction in transmittance) as θ_i approaches 90° , and thus the reflected beam will contain most of the energy except at such angles where this condition is violated by destructive interference. Hence the reflected beam will consist of dark fringes on a bright background.

With the laser beam incident on the region near the center of the plate, rotate the plate, and with the polarizer axis vertical (TE wave), rotate the glass plate and observe the transmitted and reflected beams on the screens. In particular, note the angular separation of the fringes in the reflected beam for each of

the following excitation conditions: (i) just above normal incidence, (ii) in the neighborhood of 45° angle of incidence, and (iii) near grazing incidence. Which of these three positions gives the smallest fringe separation?

Pre-Lab Assignment

Reread all the sections in the notes on multiple-beam interferometry. Summarize the key concepts and write down all the important equations you will need to understand the underlying principles being demonstrated in this experiment. Bring your summary to the Lab.

Post-Lab Assignment

- (a) For the experiment above, explain your observed results (from a theoretical point of view) for the smallest fringe separation [Hint: consider $d\delta/d\theta$].
- (b) Explain why near grazing incidence the reflected interference pattern consists of dark fringes on a bright background, while near normal incidence the pattern could be interpreted as either dark fringes on a bright background or vice versa.
- (c) What important statements can you make concerning the complementarities of the reflected and transmitted beams? Justify your statements.

2.5 Measuring the Thickness and Refractive Index of a Thin Membrane

The pellicle (membrane) is uncoated and is suspended on a rigid optically flat ring. **The membrane itself is very fragile and cannot be touched, so please handle it with care.** Neither the thickness nor the refractive index of the membrane is known, and this experiment is designed to measure both these quantities. The setup is essentially the same as that shown above in Expt. 2.4, with the membrane replacing the glass slide, the beam expander removed, and the system operated with TE polarized light.

Using the rotary table, slowly change the angle of incidence and observe the reflected beam. The reflected beam should go through several minima as the angle of incidence is changed. Carefully measure the angle of incidence for at least three minima (preferably more) nothing Δm (the difference between the order of interference) of the fringes you have chosen to measure.

Post-Lab Assignment

From your data, determine both the refractive index and the thickness of the membrane. Assume $\lambda = 0.6328 \mu\text{m}$ for the He-Ne laser.

2.6 Fabry-Perot Interferometer

The setup for the Fabry-Perot interferometer is shown in Figure 6. You will find the instrument already set up and aligned when you enter the Lab. If a well-defined circular fringe pattern is not observed on the screen, remove the diffuser and adjust one of the mirror micrometers so that the beam does not "walk off" to one side of the instrument, and then replace the diffuser. A circular fringe pattern should

now be observed on the screen. Place the screen in the focal plane of the lens, and observe the fringe pattern.

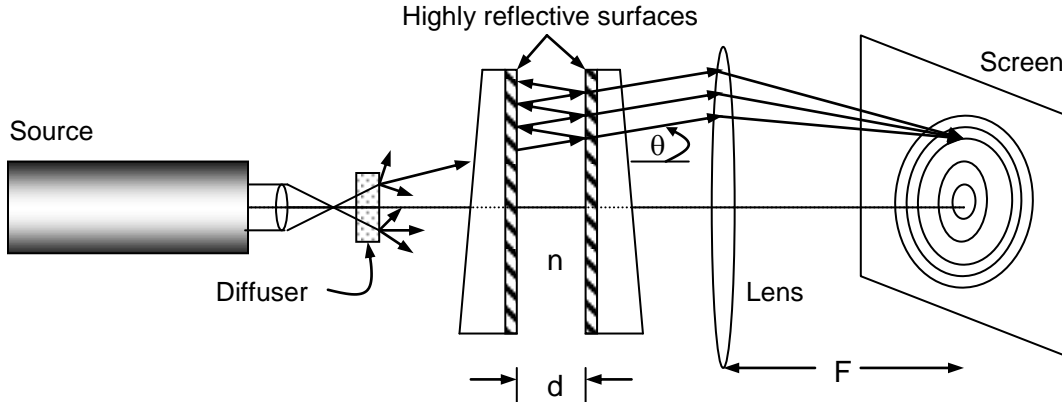

Fig. 6. The Fabry-Perot Interferometer

Pre-Lab Assignment

Reread the section in the notes on Fabry-Perot interferometer. Summarize the key concepts and write down all the important equations you will need to understand the underlying principles being demonstrated in this experiment. Bring your summary to the Lab.

In-Lab Exercise

- (a) Tape a sheet of paper (your personal screen) over the screen, trace out the first few innermost fringes, and paste your personal screen into your notebook. Measure the distance F.
- (b) Record your data, from part (a), for the measured fringe positions, calculated angular positions of the fringes, and their orders (...m-1, m, m+1...) in tabular form in your notebook. Label your sketch with the measured angles.

Post-Lab Exercise

- (1) Write the condition for a bright maximum.
- (2) Explain why circular fringes are obtained.
- (3) From the data in (a) determine the order of interference of the innermost bright ring and the thickness d of the air gap.

Hint:

Since each circular fringe is characterized by its own m and θ , by taking measurements on two fringes (preferably not adjacent) and noting that for the pair you can write

$$m_1\lambda = 2nd \cos\theta_1$$

and

$$m_2\lambda = (m_1 - \Delta m) \lambda = 2nd \cos\theta_2$$

where Δm is the difference in order between the two fringes, it then becomes possible to solve for d and m_1 .

2.7 Lummer-Gehrcke Interferometer

The Lummer-Gehrcke interferometer is illustrated in Figure 7. In our case, it is a thin glass plate with a light-coupling prism cemented onto one end of the plate. You will find the interferometer sitting on a heavy metal block, and the laser on a lab jack. **Under no circumstances should you touch the interferometer.** The plate is very fragile and, furthermore, fingerprints seriously degrade its performance.

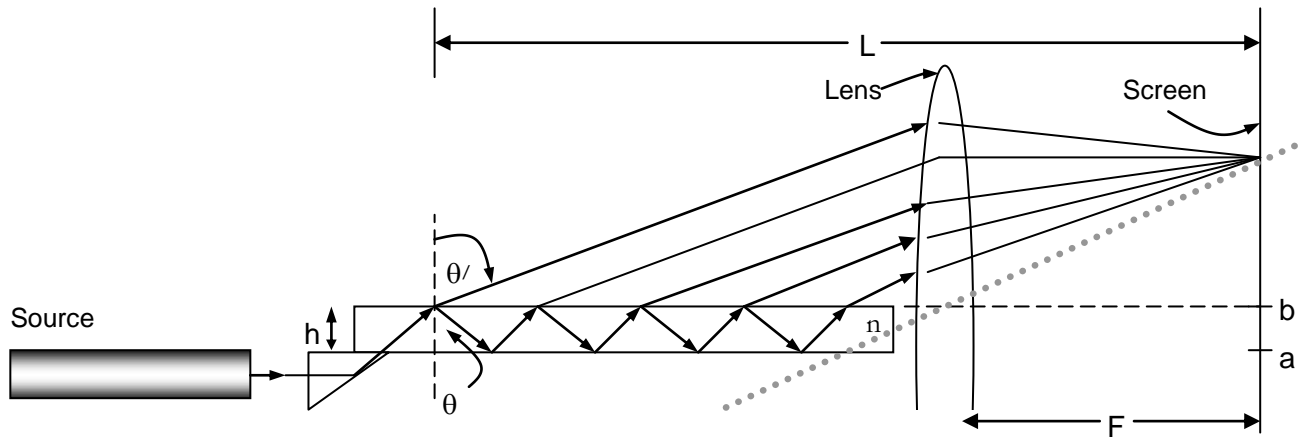

Figure 7. The Lummer-Gehrcke Interferometer

Pre-Lab Assignment

Reread the section in the notes on the Lummer Gehrcke interferometer. Summarize the key concepts and write down all the important equations you will need to understand the underlying principles being demonstrated in this experiment. Bring your summary to the Lab.

In-Lab Exercise

In order to accurately measure the angular positions of the fringes, the reference point b on the screen (where the top plane of the interferometer intersects the screen) must be found. This point is found by adjusting the height and angle of the laser beam so it just grazes the top surface of the interferometer along the entire length of the plate, and identifying the point b where the laser beam strikes the screen. Tape a sheet of paper (your personal screen) over the screen and mark the point b . The accuracy of your final results will depend critically on how well you were able to find the point b .

With the laser beam still grazing the plate, place the lens at the end of the plate as shown in the diagram, and adjust the position of the lens so that the beam hits the same point b on the screen. This assures

that the axis of the lens lies on the top surface of the plate. The screen should also be positioned one focal length behind the lens.

Now lower the lab jack back to its normal position so that the laser light is coupled into the plate via the prism. Adjust the laser beam so that the light reflected from the back of the prism returns close its original path back to the laser.

- (a) On your personal screen mark the location of at least the first six fringes above the point b. Measure the distance F (the focal length of the lens). This should also be the position where the fringes are sharpest. In your lab notebook make a table of the fringe positions, their calculated angular positions, their orders ($\dots, m-1, m, m+1, \dots$) for the first 6 fringes.
- (b) Remove the lens and re-record the position of the fringes.

Post-Lab Assignment

- (1) Explain the role of the lens in the setup, and the observed differences between the fringe pattern with the lens in place and the pattern without the lens. Under what conditions would the two patterns yield the same angular data for the position of the fringes?
- (2) Assuming that with the lens each fringe is formed by interference between successive emerging beams with the same value of θ , write the interference condition for a bright fringe.
- (3) From your data determine: (a) the order of interference, for the first bright fringe above the point b, and (b) the index of refraction of the glass at 632.8nm. Assume that the thickness of the plate is 150 μm .
- (4) Although the He-Ne laser is fairly well collimated, the interference pattern in our Lummer-Gehrcke interferometer is visible over a considerable range of exit angles. Explain why.
- (5) If a thin, isotropic film of refractive index n_2 and thickness t_2 , where t_2 is much larger than the penetration depth, was deposited on the plate, what would be the new condition for interference? Draw a new ray optics picture to help you see what is going on. How would you expect the fringe pattern to change?
- (6) The plate thickness of your interferometer is about 33 times less than that of the original instrument of the 1920's. Using the results of (5), which interferometer has the higher resolution $[(\Delta\theta_m)/\Delta t_2]$ when used for measuring thickness and index of refraction of thin films placed on the plate? (See C. Warde, Applied Optics 15, 2730 (1976))

2.8 Michelson Interferometer (Optional)

Build the interferometer you drew in the pre-lab exercise. Comment on the performance of your interferometer. Did your interferometer operate as you expected? What were some of the difficulties you encountered while aligning it? Explain the operation of the coherence-length detection interferometer to the TA.

T.A. or L.A.
Signature

If time permits, use your system to record coherence-length data for a diode laser (It is at the TA's discretion whether or not you take this measurement).

"I often say that when you can measure what you are speaking about, and express it in numbers, you know something about it; but when you cannot measure it, when you cannot express it in numbers, your knowledge is of a meagre and unsatisfactory kind."

*-- Lord Kelvin (William Thomson, 1st Baron) (1824-1907) English physicist and mathematician. In: **Popular Lectures and Addresses**, London, 1889, v. I, p. 73. See also: **Life of Lord Kelvin**, by S. P. Thompson, 1910, V. 2, p. 792*

APPENDIX

Student:

Date: Lab:

Grade:

CI Instructor: Don Unger

6.161 CI-M, Lab Write-Up Rubric, Fall 2011

	Okay	Good	Excellent	Comments
Content				
Provides a <i>well balanced</i> introduction to the experiment	10	14	17	Category Max 51 points
Report is complete, has a beginning/overview, middle, and end				
Data is clearly conveyed and coherently explained ¹				
Style and Delivery				
Language is clear	1	3	5	Category Max 25 points
Language is appropriately professional				
Format specifications followed				
Surface errors minimal				
Keeps to word/page limitations				
Graphics				
All graphics are clear--both individually and as grouped--and necessary	2	4	6	Category Max 24 points
Titles, captions, credits, all done in discipline-appropriate fashion				
Graphics are not overly text-dense; narration is not replaced by a stream of equations				
Data presentation: legible, uncrowded, properly labeled, symbols distinct, error bars and plot points present; color used for clarity rather than style				

1. You may get a result which you know to be incorrect. Your job is still clearly to lay out what happened and to provide your best explanation for why it happened.

V 1.0 3Jul2011 DNSU