

MASSACHUSETTS INSTITUTE of TECHNOLOGY
Department of Electrical Engineering and Computer Science

6.237 Modern Optics Project Laboratory
6.637 Optical Signals, Devices & Systems

Problem Set No. 3
Fall Term, 2024

Coherence and Interference

Issued Thrs. 09/26/2024
Due Tues. 10/08/2024

Reading recommendation: Class Notes, Chapter 3. Be neat in your work!

6.161 STUDENTS: Do any four

6.637 STUDENTS Do all five

Problem 3.1

Two mutually coherent intersecting plane waves of equal amplitude A , wavelength λ_1 and separation angle θ , are incident symmetrically on a planar slab of holographic recording material of refractive index n as shown.

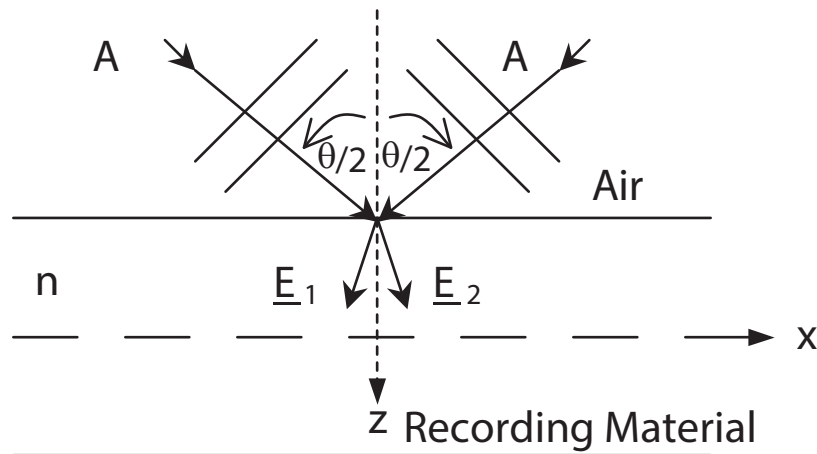

- Write equations for the two waves inside the slab.
- Assuming the phase difference between the waves is zero at $(x = 0, z = 0)$, use your equations to derive expressions for the separation Λ of the interference fringes in the material.
- Show via geometric construction of the fringes that your results are correct. (Hint: Draw the wavefronts in the medium and identify the regions of constructive interference)

Problem 3.2

Part 3.2.1

A plane wave of TM-polarized light ($\lambda = 500\text{nm}$) is incident upon a thin planar polymeric membrane of refractive index $n = 1.3$ and thickness $h \mu\text{m}$ at the Brewster angle. The wavelength of the light is $0.5 \mu\text{m}$

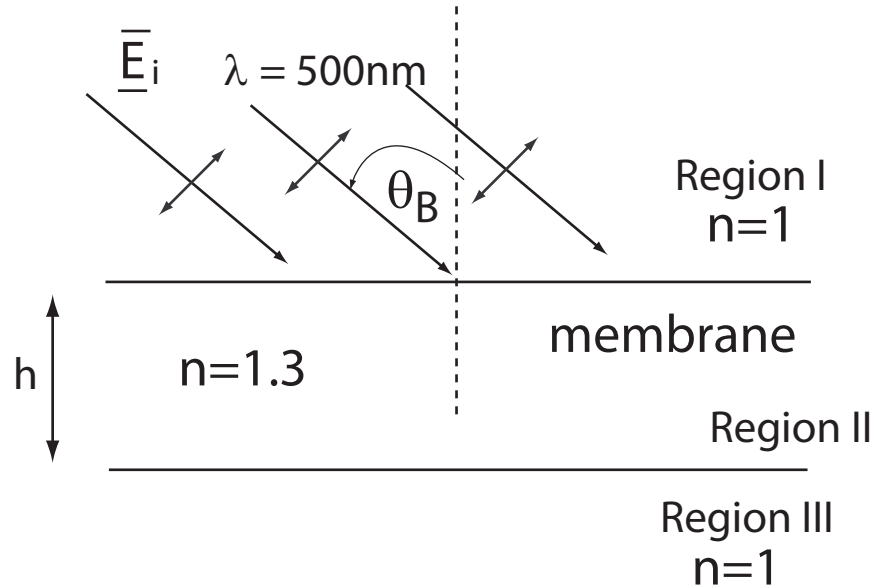

- What is this angle of incidence?
- Are there fringes in Region I arising from the reflected beam? Show your reasoning. If so, what is the interference condition for a bright maximum?
- Are there fringes in Region III arising from the transmitted beam? Show your reasoning. If so, what is the interference condition for a bright maximum?

Suppose the polarization of the beam, still incident at the Brewster angle, is now changed to **TE** polarization:

- Give an expression for the **total** reflectivity R_{TE} of the air-membrane system.
- Ignoring diffraction, what is the minimum thickness h of the membrane (in microns) that puts maximum power into reflected wave at this angle of incidence (Brewster angle)? (Show your reasoning)

Part 3.2.2

A thin, plane-parallel transparent polymer membrane is stretched across a flat hoop as shown in the figure below. The index of refraction, n , of the membrane and its thickness h are unknown. In order to measure these two quantities, a student places the membrane on a rotary stage and illuminates the membrane with a collimated laser beam of wave length λ . She varies the angle of incidence, θ , and she observes that adjacent reflection minima occur for angles of incidence θ_1 , θ_2 , θ_3 only.

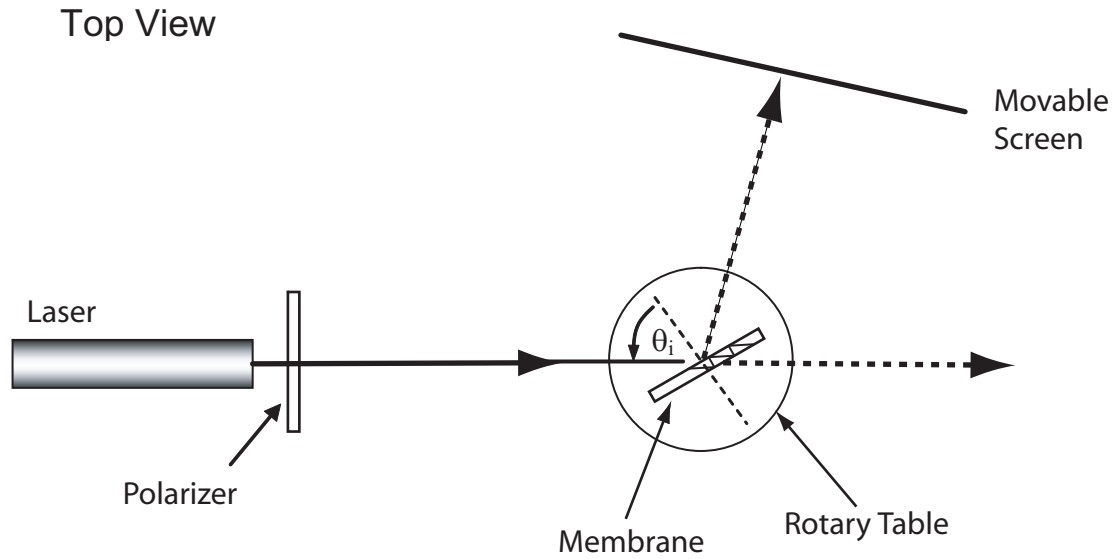

- Derive an expression for the membrane thickness h .
- Assuming the illumination wavelength is fixed, and the refractive index is constant but unknown, as the membrane thickness decreases, what are the experimental conditions that limit the usefulness of this method for measuring membrane thickness and refractive index simultaneously?
- What is the minimum optical membrane thickness that can be measured by this method?
- If the index of refraction, n , of the membrane was known, what is the minimum physical membrane thickness that can be measured by this method?

Problem 3.3

A long focal length plano-concave lens is made from this material. The parabolic curved surface of the lens is given by the equation, $h = a\rho^2$, where ρ is the cylindrical coordinate with the origin at the bottom of the paraboloid. The lens is round with a diameter D . The lens is placed on an optical flat of the same material with the concave side towards the flat surface of the optical flat. Both the concave surface of the lens and the reference surface of the optical flat are coated with a thin material with a high reflectivity (about 90%), just for this experiment. The system is operated with monochromatic light of wavelength λ as shown, and Newton's rings are observed.

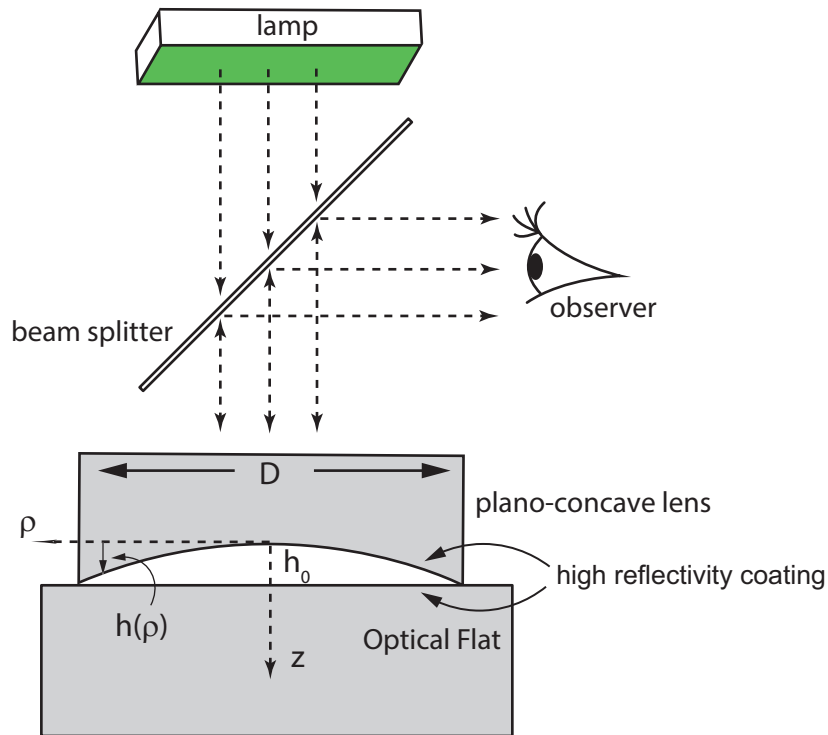

- Are the fringes dark on a bright background or vice versa?
- It so happens that there is a dark central fringe at $\rho = 0$ for this particular system. What is the order of interference, m_0 , at the center of the system?
- What is the radius of the first dark ring closest to the center of the system?
- How many dark rings in total are observed?

Problem 3.4

The Young's double slit experiment is modified, as shown below, by placing a thin parallel glass plate of thickness d and refractive index n over one of the slits. Here a is the slit width in the x direction and b is the slit separation also in the x direction. The system is excited with on-axis collimated laser light of wavelength λ . A lens of focal length F is placed immediately behind the slits and a screen is placed a distance F away from the lens, so that a set of well-defined interference fringes are visible on the screen. Ignore all phase changes from reflection and transmission in this problem.

- For the case where the glass plate is absent, derive an expression for the position, X_{2m} , of the m th maximum on the screen.
- Derive an expression for the spatial frequency shift $\Delta f = [(\sin \theta')/\lambda - (\sin \theta)/\lambda]$ that occurs when the glass slide is inserted in the position shown in the diagram. What important conclusion do you draw from your expression?
- Derive an expression for the lateral spatial shift $\Delta X_{2m} = X'_{2m} - X_{2m}$ on the screen as a result of inserting the glass slide.
- In which direction do the fringes shift?

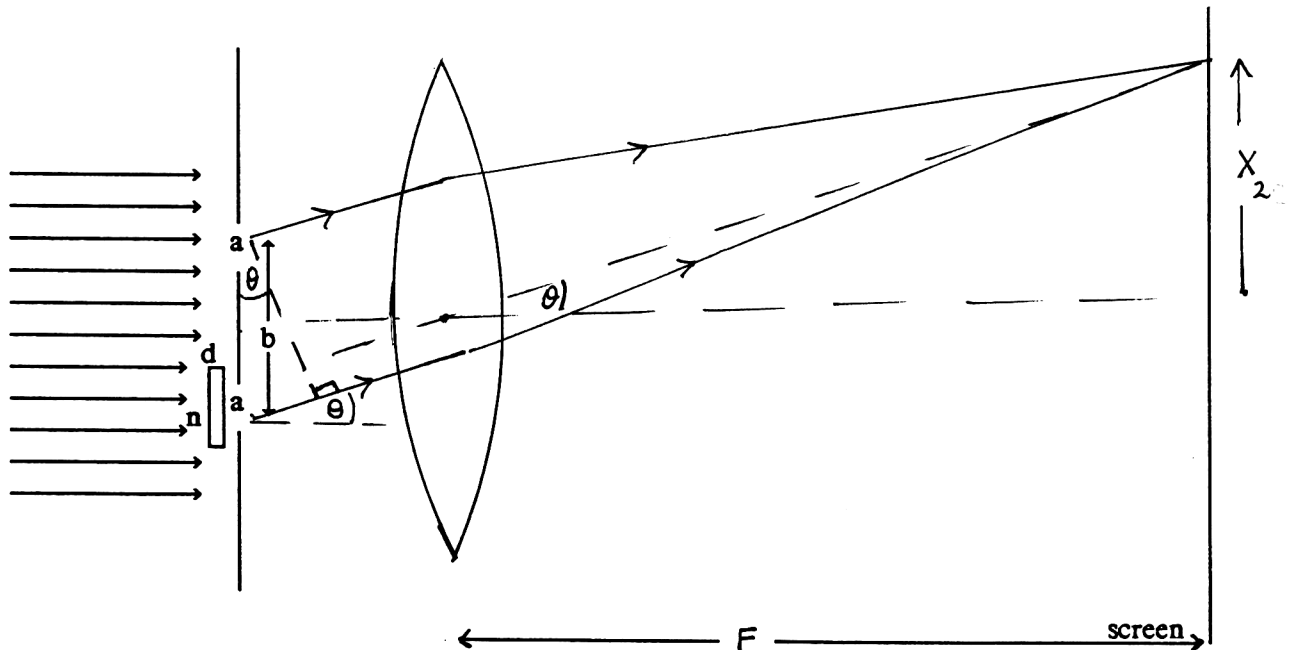

Problem 3.5

The general multiple-beam interference ray optics diagram presented and analysed the class notes (shown below) does not faithfully apply to the Lummer-Gehrcke interferometer. This is because the very first and strongest reflected ray does not exist in the Lummer-Gehrcke system. Following

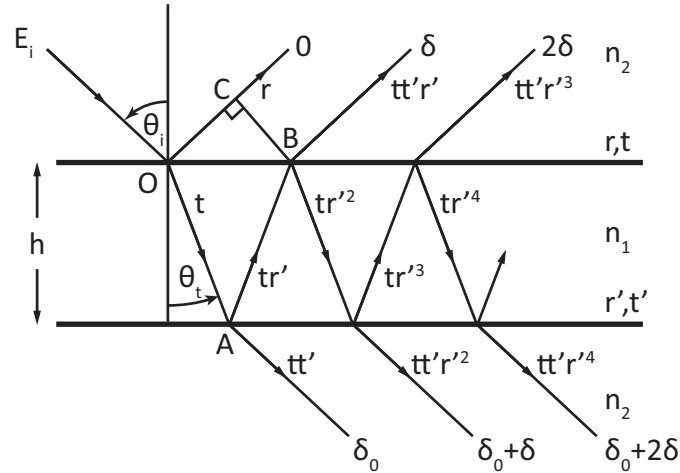

Figure 1: Multiple-beam reflection and transmission from a thin plane parallel film

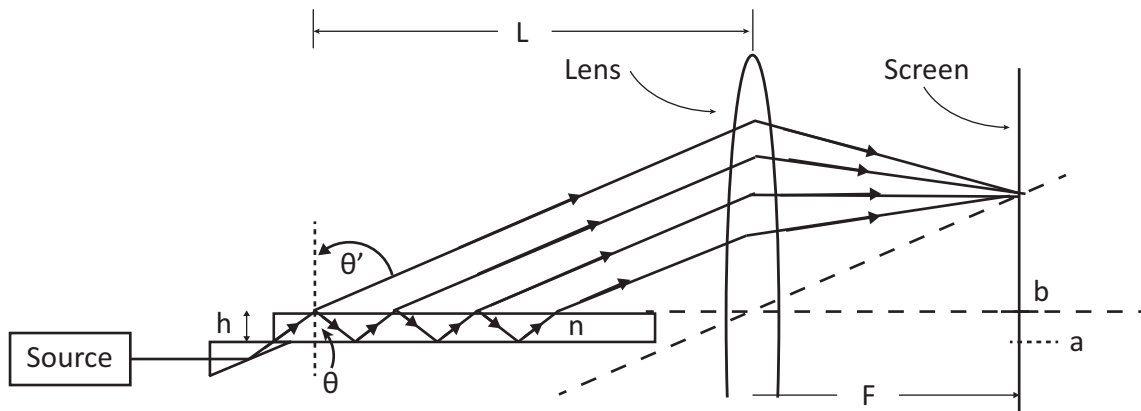

Figure 2: The Lummer-Gehrcke Interferometer

the same procedure used in the notes for the general multiple beam case:

- Derive the expression for the total transmitted intensity through the top surface of the plate in terms of the reflectivity R of the surface.
- Derive the expression for the total transmitted intensity through the bottom surface of the plate in terms of the reflectivity R of the surface
- What is the condition for resonance?
- Are your answers for (a) and (b) in agreement with the conservation of energy? If not, where is the missing energy?
- What is the contrast ratio of the intensity fringe patterns, defined here as $CR = I_{max}/I_{min}$?