

Reading recommendation: Class Notes, Chapter 8. Be neat in your work!

Problem 8.1

We know that if an object is placed in the front focal plane of a lens, the field in the back focal plane of the lens is related to the Fourier transform of the object. We also know that the far-field diffraction pattern of an object is related to the Fourier transform of that object. Make a list of the similarities and differences between the Fourier transforms formed by these two systems. Explain each of the differences with the aid of diagrams and an example such as a circular aperture, or a slit, or rectangular grid, etc.

Problem 8.2

It is well known that a lens will image a point-source at a distance $2F$ in front of the lens to a point at a distance $2F$ in back of the lens as shown.

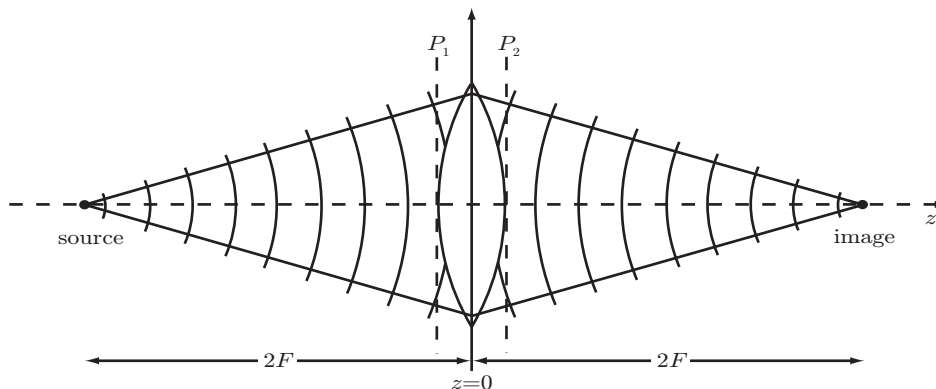

- (a) Write an expression for the wavefront incident on the lens $\underline{U}_1(\bar{\rho}_1)$ at the plane, P_1 , located at $z = 0_-$ (lens is thin).
- (b) Using the paraxial approximation, simplify the expression obtained in part (a).
- (c) Similarly, write an expression for the wavefront exiting the lens $\underline{U}_2(\bar{\rho}_2)$ at the plane, P_2 , located at $z = 0_+$ (lens is thin).
- (d) Using the paraxial approximation, simplify the expression obtained in part (c).
- (e) What then is the expression for the thin lens transformation $t_l(\bar{\rho})$?

Problem 8.3

In a classical two-lens coherent optical processor with lenses of focal length F , two signal transparencies of transmittance $g_a(x_1, y_1)$ and $g_b(x_1, y_1)$ are inserted in the $\bar{\rho}_1$ (input) plane with centers at $(a, 0, 0)$ and $(-a, 0, 0)$ respectively. The Fourier-plane filter $t_h(\bar{\rho})$ is a sinusoidal grating with amplitude transmittance

$$t_h(\bar{\rho}) = t_h(F\lambda \bar{f}) = \frac{1}{2} + \frac{1}{2} \sin(2\pi f_g x + \phi)$$

where f_g and ϕ represent the grating frequency and position respectively.

- (a) Calculate the complex amplitude distribution at the output plane of the processor.
- (b) For the special case where $f_g = a/\lambda F$ and $\phi = 0$, comment on the significance of the output. Repeat the process for $\phi = 90^\circ$.

Problem 8.4. - Cylindrical-lens Fourier Optics

- (a) Consider the thin cylindrical lens shown below. Write an equation for the thin cylindrical lens transformation $t_{cl}(x, y)$.

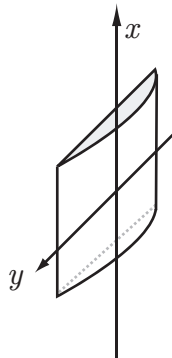

- (b) A classical two-cylindrical lens coherent processor is built as shown below. The lenses L_1 and L_2 each have focal length F . Such a system can be used to process 1-D objects $\underline{g}(x, y)$ using 1-D Fourier plane filters, $\underline{t}(x, y)$. Indicate on the diagram how the 1-D object, $\underline{g}(x, y)$ and the filter $\underline{t}(x, y)$ must be oriented to properly function in this system.

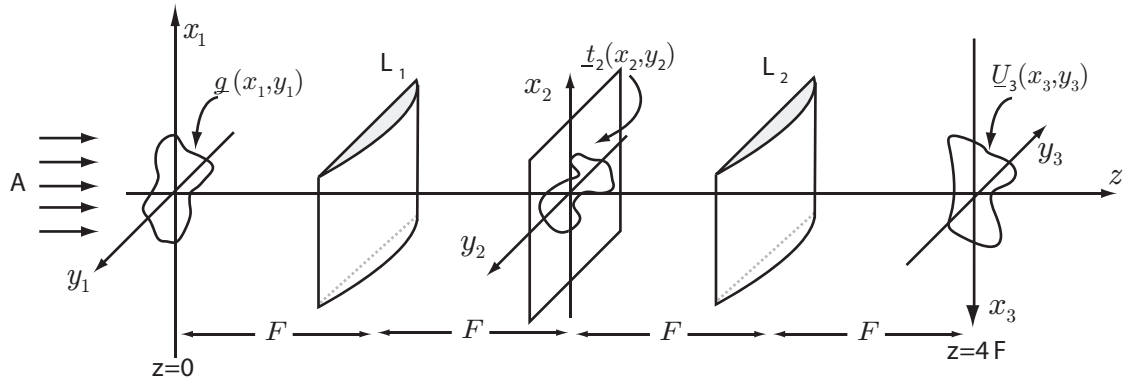

- (c) Write an equation for the input-output characteristics of the system. That is, express $\underline{U}_3(x_3, y_3)$ in terms of $\underline{U}_1(x_1, y_1)$.
- (d) Two plano-convex cylindrical lenses are crossed and fused together to form a compound lens as shown below.

d(1) Write the lens transformation for this compound lens assuming the two original lenses had the same focal length.

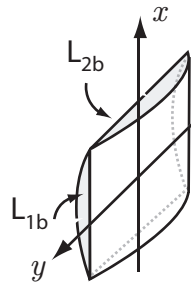

- d(2) What is the focal length of the compound lens?
- (e) A classical two-compound lens coherent processor is built as shown below. Write an equation for the input-output characteristic of the system. That is, express $\underline{U}_3(x_3, y_3)$ in terms of $\underline{U}_1(x_1, y_1)$

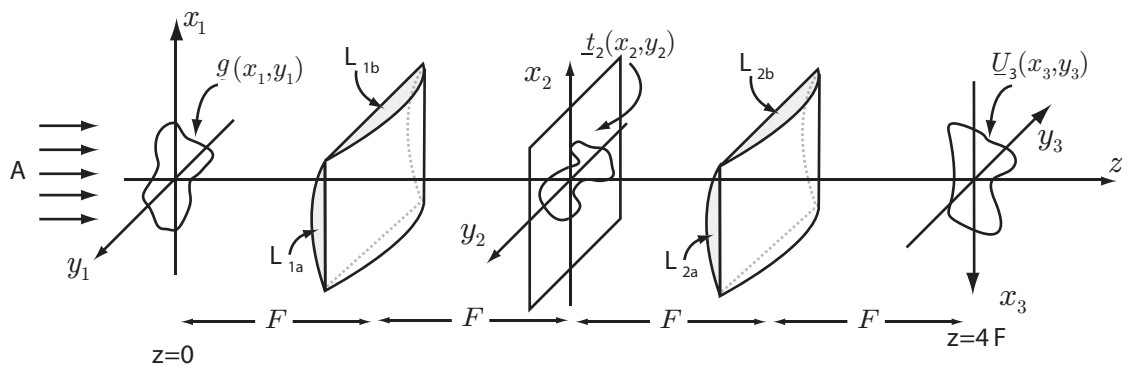

Problem 8.5 - 6.637 only

In the polychromatic optical processor shown below, S is a white-light point source, and L_0 , L_1 and L_2 are achromatic lenses. Two three-color (each monochromatic) signal transparencies $g_a(x, y, \lambda)$ and $g_b(x, y, \lambda)$ are placed in the input plane P_1 at the points $(0, d)$ and $(0, -d)$ respectively and in contact with a high-efficiency diffraction grating $G(x, y)$. Assume the two input signal color transparencies, $g_a(x, y, \lambda)$ and $g_b(x, y, \lambda)$, each have a spatial frequency bandwidth limit of $B_x \times B_y$. The transmission function of the in-plane grating is given by

$$t_G(x, y) = \frac{1}{2}[1 + \cos(2\pi f_g x)]$$

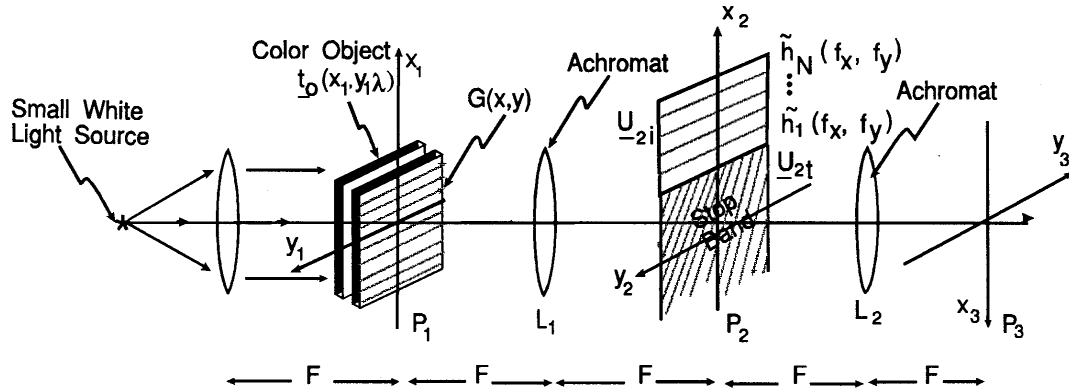

(a) Write an expression for $U_{2i}(x, y, \lambda_n)$ where n is the color subscript. Here [$n=1$ (red), 2 (green), 3 (blue)].

(b) Explain/interpret each term in the equation you have derived in (a). For $n = 1, 2, 3$ make a sketch of the pattern of the light falling on the P_2 plane, and label the position of the centroid of each of the components.

(c) Suppose the Fourier-plane composite filter in the P_2 plane is composed of a set of non-overlapping subfilters given by

$$t_h(x_2, y_2) = \tilde{h}(f_x, f_y) = \sum_n (1/2)[1 + \sin(2\pi d f_{yn})] \quad (1)$$

for the first-order spectra, but is opaque for the zero and -1 orders. Sketch the three subfilters, corresponding to the three values of n , in physical space.

(d) Write an expression for the output $U_3(f_x, f_y, \lambda)$ in the P_3 plane for one of the colors using its corresponding Fourier-plane subfilter.

(e) To perform full color subtraction, we must synthesize the composite filter $\tilde{h}(f_x, f_y)$. Make a sketch of the desired composite filter. On your diagram clearly specify and give expressions for: (1) its periodicity, Λ_{yy} , (2) the centroids and (3) widths of the filter segments (if any), and (4) the location of the desired subtraction image, $g_a(x, y, \lambda) - g_b(x, y, \lambda)$, in the output plane.

(f) What are the conditions on λ_n , f_g , B_x , B_y and F so that the desired output image is clearly separated from other images in the output plane?

(g) Comment on the practical limitations of this system.

Problem 8.6 - 6.637 only

You are given a thin convex lens of focal length F and told to find the matched filter that “identifies” the given lens. So, following standard practice, you place the given lens in the input plane of a 4- F classical two-lens processor as shown in the Figure below, and you start trying various filters that you have found lying around the lab.

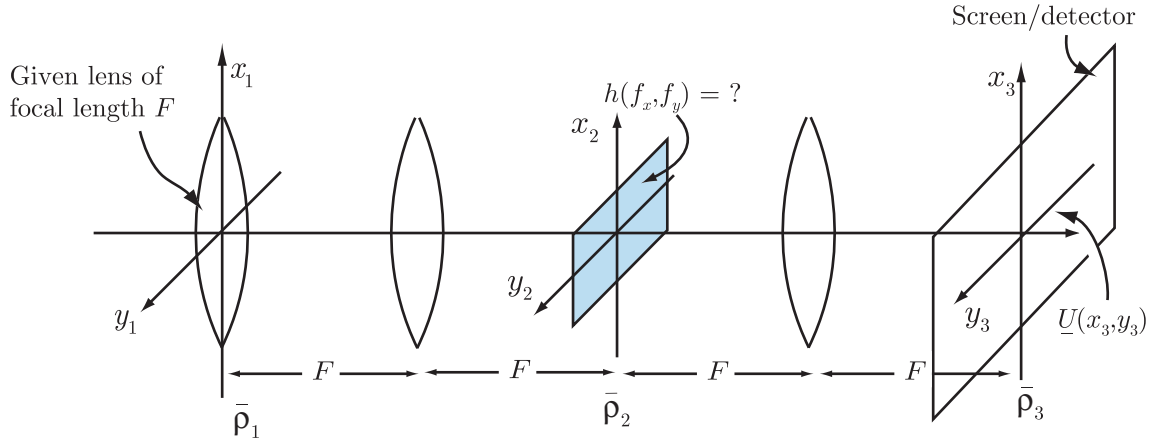

- Write down the equation for $\underline{U}_1(\bar{\rho}_1)$ for the system as shown above, assuming collimated input light.
- What will the output, $\underline{U}_3(\bar{\rho}_3)$, look like on a screen/detector in the $\bar{\rho}_3$ plane when you have found the perfect matched filter?
- What is the functional form (give equation) of the Fourier-plane filter, $\tilde{h}(\bar{f})$, that will do the trick?
- Describe with words exactly what this matched filter is in real space, and write an expression for its transmission function, $\underline{h}(\bar{\rho})$.
- Draw a ray optics picture for the complete system to justify/support your wave-optics answers in (a), (b) and (c).