

6.163 Lecture Notes on Strobe Circuit Model

Dr. James W. Bales (bales@mit.edu) 26 October 2009

Bring to class:
Strobe Tubes

Strobe Circuit Model

Hand out sample strobe lamps. Note that there is no filament. State that the tube is filled with Xe. Note the third wire -- the trigger wire -- around the outside of the tube.

Circuit Model

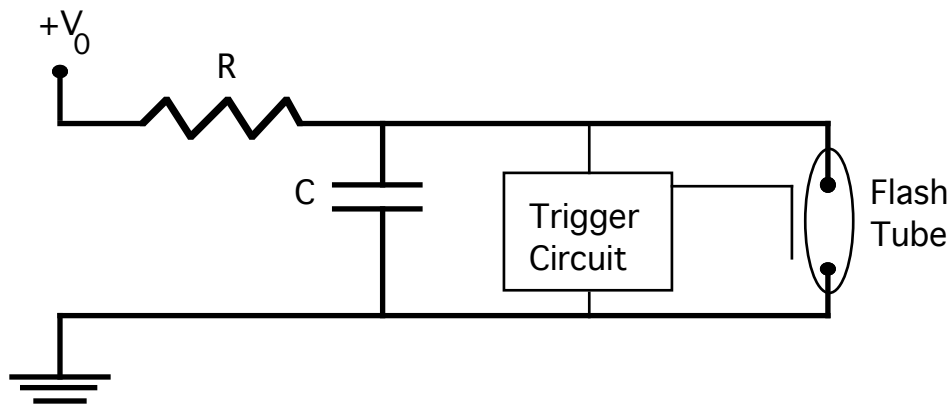

Figure 1. Our model of a strobe circuit. The trigger circuit is assumed to draw no current. The flash tube is assumed to be an open circuit until triggered, and then to have a very low resistance until the arc quenches (i.e., the flash is complete), at which point the tube returns to being an open circuit.

Figure 1 shows our model of the strobe circuit. It is essentially an RC circuit to charge a capacitor, a flash tube (a glass tube filled with gas that contains 2 electrodes and has a third wire wrapped around the outside), and a "triggering circuit" which we assume to draw no current. The flash tube is assumed to be an open circuit until triggered, and then to have a very low resistance until the arc quenches (i.e., the flash is complete), at which point the tube returns to being an open circuit.

Process

Discuss the process by which the circuit works.

- Capacitor charges as per the RC circuit.
- The applied voltage, V_0 , is not sufficient to cause breakdown of the Xe in the flash tube.
- A trigger signal (not shown) causes the trigger circuit to place a very high voltage (10+ kV) on the trigger wire, causing a portion of the gas in the tube to ionize. This causes the tube to conduct between its main electrodes. That current heats the Xe gas, further ionizing the gas, which increases the electrical conductivity, causing more current to flow, ionizing the gas yet *more*, ... until all of the gas is a plasma, a white-hot mass of ionized Xe. The flash is simply the light emitted by this plasma.

- d. The high conductivity of the plasma quickly drains charge from the capacitor. Soon, the power level being dissipated in the tube is too low to maintain the gas at such extreme temperatures, so the gas starts to cool. The Xe ions recapture their electrons, quenching the plasma, and the current stops.
- e. The tube rapidly cools until it stops emitting light. (This takes about a microsecond for Xe, less time for air).

Quantifying the Performance

Given a capacitor of capacitance C , charged to a voltage V_0 , the electrical energy stored in the capacitor (E_{CAP}) is given by

$$E_{CAP} = \frac{1}{2} CV_0^2. \quad \text{Eq. 1}$$

The flash tube converts that energy into light with some *efficacy*, ϵ . The efficacy has units of CPS/J (CPS, or CandlePower-Seconds, being the time-integrated light from the flash tube emitted in all directions.).

The efficacy can range from about 1 to 10. This may bother you, as it is greater than 100%! That is OK, for the units of the light output, CPS, are not the light energy, but are the light energy normalized to the human eye response. (For most visible colors of light, one Joule converts to tens or even hundreds of candlepower-seconds).

Finally, the flash tube sits (usually) inside a reflector that catches the light emitted in all directions and concentrates the light into a beam. This is characterized by a *reflector factor*, RF , which is the light intensity in the beam ($BCPS$) divided by the light emitted from the flash tube (CPS). The final output of the strobe ($BCPS$) is thus just the product of the energy in the capacity, the efficacy, and the reflector factor, i.e.,

$$BCPS = RF \cdot \epsilon \cdot E_{CAP} = RF \cdot \epsilon \cdot \left(\frac{1}{2} CV_0^2 \right). \quad \text{Eq. 2}$$

Charging Time

Once we fire the strobe, we need to wait for the capacitor to recharge before firing the strobe again. If we wait one time constant, the voltage across the capacitor is approximately 2/3 of the final value. Three time constants gets the voltage to better than 95% of the final value,

For our purposes, if we *wait at least three times the RC time constant between flashes*, we will have enough energy in the capacitor for the flash to have essentially its full intensity.