

6.302 Feedback Systems

Spring Term 2008
Problem Set 9

Issued : April 15, 2008
Due : *Thursday*, April 24, 2008

This problem set is short since you will be/are hard at work on the Motor-Lab Take-Home quiz and Design Problem. Please use this time wisely!

Problem 1: In order to complete your advanced undergraduate project, you find that you need to control the current flowing through an inductor very precisely. Since it is nearing the end of April, however, you want to construct the control circuit as quickly as possible. You therefore build the circuit shown below.

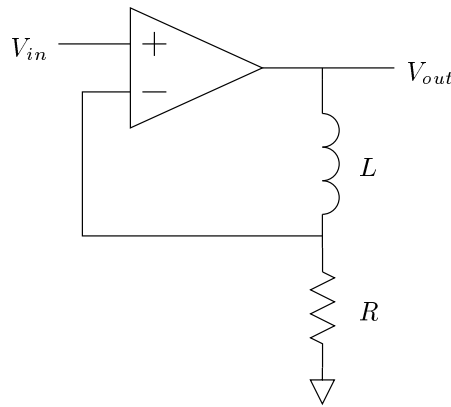

The inductor has a value of 1 mH, and the currents which you expect to measure suggest that you use a resistor of 100Ω . Since you are such a whiz at 6.302, you use an externally compensated op amp. This system has a block diagram which appears below.

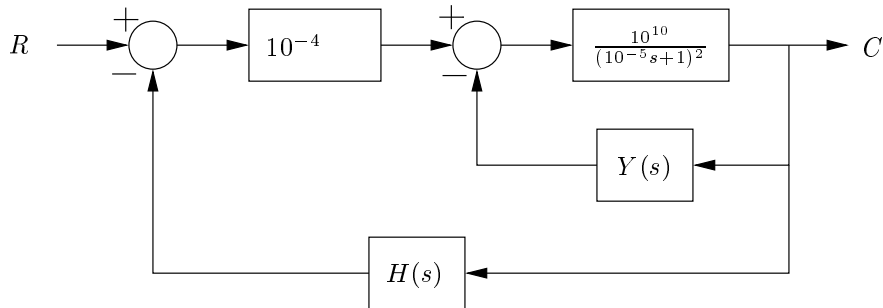

In this block diagram, $Y(s)$ is the admittance of a two terminal compensating network. You initially choose a 10 pF capacitor for compensation, which results in $Y(s) = 10^{-11}s$. As a sanity check, you initially test your op amp under unity feedback ($H(s) = 1$).

- (a) Draw the Bode plot for the loop transmission of this system, and calculate the phase margin with this compensator.

Now that you are satisfied with the performance of your op-amp, you decide to implement your current control scheme ($H(s) = \frac{R}{Ls+R}$). When you turn the system on, however, you find that it is unstable.

- (b) Draw the Bode plot for the loop transmission of your current control scheme, and find the phase margin.
- (c) Construct a new admittance function $Y(s)$ which will make the closed loop system with the inductive load meet the same phase margin performance as your initial test circuit did with frequency independent feedback.
- (d) Draw the circuit which you would use to implement this $Y(s)$.