

Massachusetts Institute of Technology  
Department of Electrical Engineering and Computer Science  
6.685 Electric Machines

Problem Set 1

Issued September 7, 2005  
Due September 14, 2005

**Reading Assignment:** Course Notes, Chapter 1

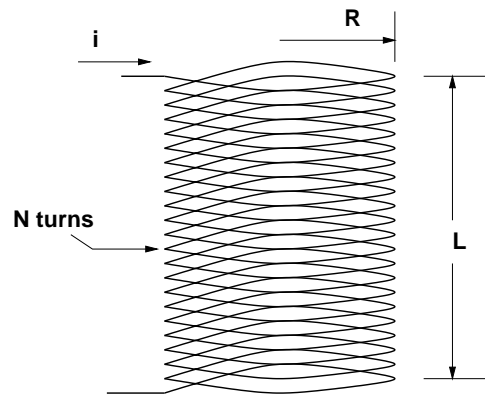

Figure 1: Coil for Problem 1

**Problem 1:** (Ripped off from Fitzgerald, Kingsley and Umans, Fifth Edition, Problem 3-19). Do this problem using *both* energy methods and the Maxwell Stress Tensor. You should get the same answer! Figure 1 shows a simple, circular coil, with radius  $R$ , axial length  $L$  and with  $N$  turns. The coil carries current  $i$ . Assume this solenoid is long relative to its diameter ( $L \gg R$ ), so that the magnetic field inside the cylinder is axially directed and essentially uniform, and that fields external to the coil may be neglected. Calculate the radial pressure acting on the sides of the coil for constant coil current  $i = I_0$ . What is the hoop force (force per unit of length) acting on the coil?

**Problem 2:** A conductive cylinder, with conductivity  $\sigma$  and thickness  $t$  is inserted into the coil of Problem 1 as shown in Figure 2. . Current in the coil is driven (by a mechanism not shown) to be as is shown in Figure 3. You should assume that the geometry is as idealized in Problem 1 and that you may ignore diffusion in the cylinder. (That is, assume that current is uniform over the thickness of the cylinder.) In addition, assume current in the shell to be azimuthal. Assume the coil is 1000 turns of wire 2 mm in diameter (#12 AWG) and that conductivity of the wire is  $5 \times 10^7 S/m$ . The diameter of the conductive cylinder is 200 mm and its thickness is 1 mm. It is made of the same sort of copper as the wire and so has the same conductivity. You will find it convenient to use some sort of mathematical assistant to do the work of doing the actual calculations and plotting the results. The solutions to be passed out will be done using MATLAB.

1. Estimate and plot the hoop force in this conductive cylinder as a function of time.

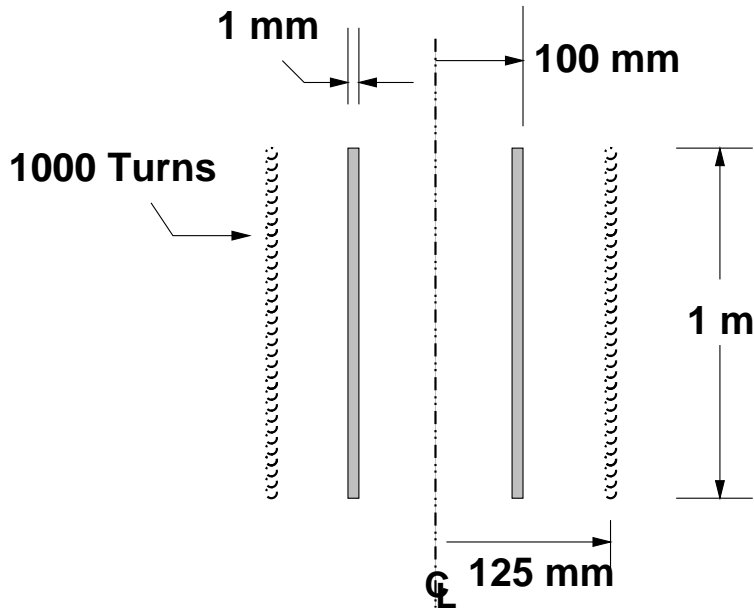

Figure 2: Coil for Problem 2

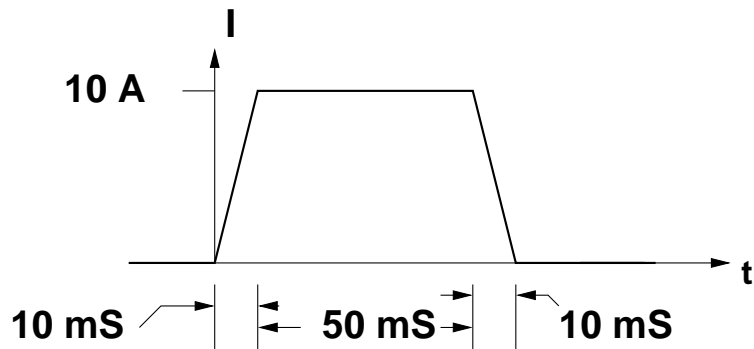

Figure 3: Current in coil for Problem 2

2. Estimate and plot terminal voltage of the coil as a function of time.
3. Estimate and plot electrical dissipation in the conductive cylinder as a function of time.

**Problem 3:** The objective of this problem is to do a rough sizing of the rotor of an electric motor. the machine in question is rated at 1 MW and is fed by a constant frequency supply of 60 Hz. Assuming that the machine develops a shear stress of 100 kPa, and assuming any slip is small:

1. What is the rotor volume of the machine if it has two, four or six poles?
2. Assuming that active rotor length is twice rotor diameter, what are length and diameter for each of the three cases cited in the first part of the problem?