

Physics 8.01 2004

Welcome:

Web URL: [web.mit.edu/8.01/www/Fall04](http://web.mit.edu/8.01/www/Fall04)

### General Information

Lectures: SK

Adm/Exams/Homework: Peter Fisher

Course Manager: Maria Springer

8:01 Office: 4-352 Sections, etc.

Text: University Physics, 11<sup>ed</sup> Young + Freedman  
Study Guide: Intr. Classical Mechanics  
Buzza, Cartwright, Guth

Lectures: MWF 10-11 26-100  
11-12

Recitations: MW 25 sections 2/wk  
TR

Homework/Quizzes

Mastering Physics

Switching Sections

- New Instructor's Permission
- Notify UG Physics Office.

Add Date  
Drop Date

## Class Quizzes:

Q1: F Oct-1

Q2: F Oct-29

Q3: F Nov-19

## Makeup

T Oct-12

T Nov-9

T Nov-30

Final Exam: Dec 3 Rvs

No valid excuse → zero

## Grading

Quizzes 36%

Final 36%

Homework 9%

Recitation 10%

Mastering Physics 9%

## Laboratory

No formal laboratory

Lecture demonstrations

There are approximately 700 students taking 8.01 with a broad spectrum of skills and experience.

Physics: There are students who have seen essentially no physics previously. There are others who are just shy of Advanced Placement in 8.01.

Math/Calculus: Calculus is an essential tool for teaching physics — we will start slowly but increase its use rapidly. Many here have advanced placed 18.01. I will not take advantage of that in fairness to others but will try and pace what you are learning in 18.01

- Algebra
- Trigonometry
  - Must have the facility at your fingertips
- Vectors
  - Can't wait for 18.01/18.02
  - Introductory lecture in 8.01

Options:

8.012 More challenging option / Calculus, Vectors

Delay 8.01 to 2<sup>nd</sup> Term. / Issue of Major Choice

## Commitment

This will not be a course for memorizing a lot of formulas, etc.

I will try to teach you about concepts, ideas and the laws of mechanics — as well as some of the important principles of physics. You will be required to apply these to PROBLEMS.

- 3 Hrs lectures
- 2 Hrs Recitation
- 7 Hrs Homework (~Average)
- 12 Hrs/Wk.

If you make this level-of-commitment you will learn a lot of physics and have no trouble passing.

Recitations will help you in doing the problems and explaining some physics not completely covered in lecture. They are important!!

Tutors will also be available. Schedule will be announced later.

If you decide to switch recitations:

- Must have permission of new instructor
- Must notify UP Office.

## Physics

1-5a

As you proceed with your study of physics for the next two terms you will learn about the achievements of such scientific giants as Galileo, Copernicus, Newton, Maxwell and Einstein whose work among others forms the foundation of our present understanding of the physical world.

We begin in 8.01 our study of physics with the subject of mechanics — the study of motion and its causes. A natural starting point since everyday experience offers many examples of mechanical principles — more so than any other area of physics.

We will introduce the language of physics:

- measurement units / standards
- calculational techniques / calculus
- vector algebra

We start by developing a language for describing motion.

- An ideal particle moving along a straight line
- Motion in a plane,
  - parabolic motion / ballistics
  - circular path motion

The big step will be to consider the relationship between motion and the forces that are always associated with it. Whenever a particle speeds up, slows down or changes the direction of its motion — there is always an associated force. The relationship between force and motion is contained in Newton's three laws of motion.

Physics is an experimental science. We will see the interplay between Theory and experiment. Every physical theory must ultimately be grounded in experimental observations of phenomena in the physical world.

I will try to teach you, along with my colleagues how to apply these laws to solving practical problems. To develop systematic problem solving procedures that help to set up problems and carry out solutions efficiently and accurately.

You will see some of the beauty and symmetry of physics when you see how the essential relationships of mechanics are all described in a neat and compact package, called "Newton's Laws of Motion".

## Classical Mechanics

1-6

In the study of mechanics we shall concern ourselves with the motion of a particle. This motion is described by giving its position as a function of time.

Specific position + time  $\Rightarrow$  event  
Position  $\Rightarrow$  velocity  $\Rightarrow$  acceleration

## Ideal Particle

- classical physics concept
- pointlike object/no size
- mass

Measurements of position, time and mass completely describe this ideal classical particle

- elementary particles have charge, spin — Ignore!

## Position :

If a particle moves along  $\omega$  :

- curve  $\rightarrow$  1-coordinate
- surface  $\rightarrow$  2-coordinates
- volume  $\rightarrow$  3-coordinates

General description requires a coordinate system with an origin.

- fixed reference point, origin
- a set of axes or directions
- instructions on labelling a point relative to origin+axes

# Rectangular Coordinates

↳ 'Cartesian'

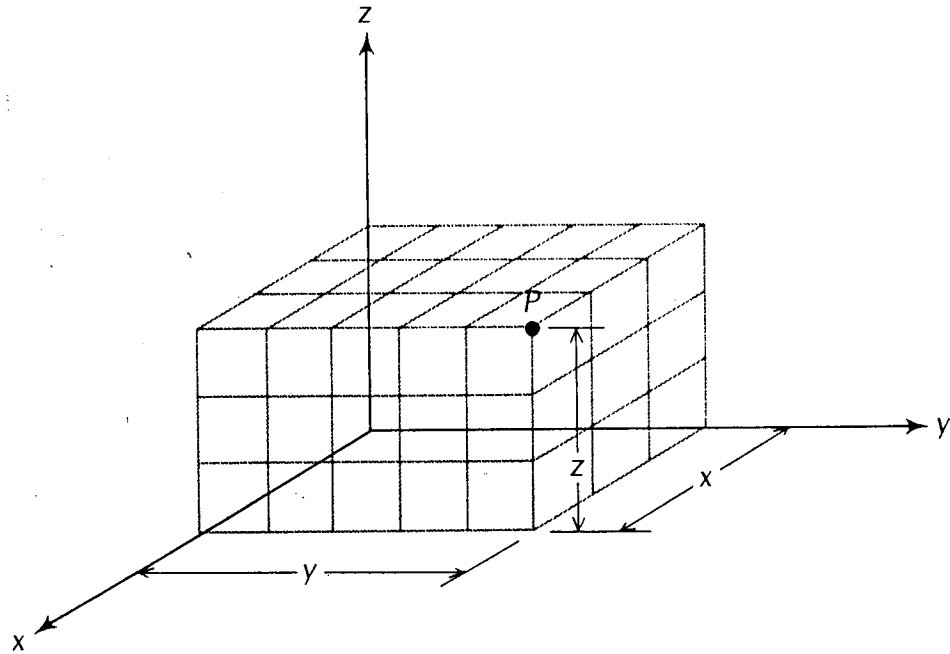

- simplest system
- easiest to visualize

## Spherical Coordinates

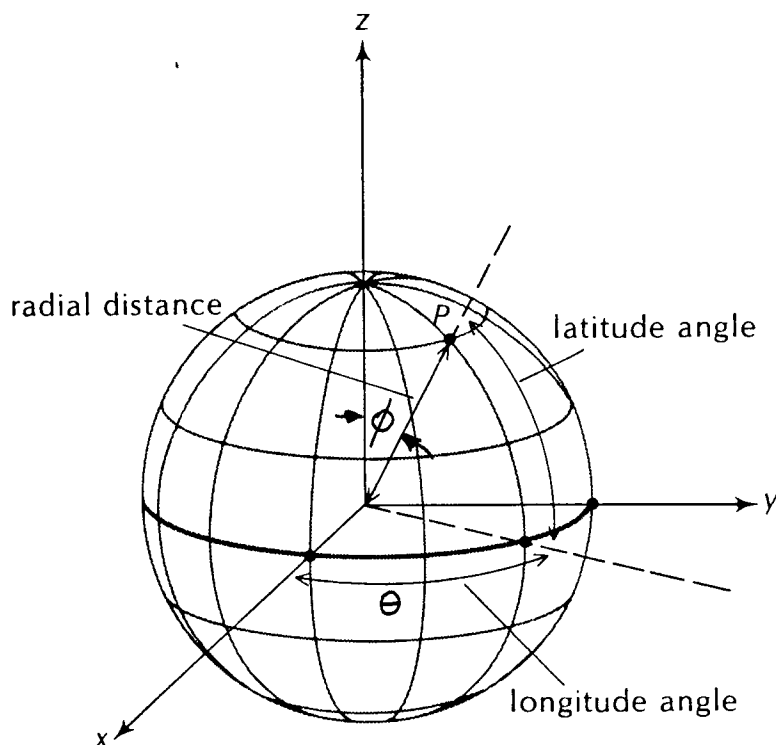

- Still need 3-numbers to specify completely
- Nice system for motions on a spherical surface

$r \rightarrow$  distance from origin to point  $P(r, \theta, \phi)$

$\phi \rightarrow$  angle between line through poles ( $z$ -axis) and line  $\overline{OP}$ . (latitude =  $\pi/2 - \phi$ )

$\theta \rightarrow$  angle in  $xy$ -plane measured from  $x$ -axis related to longitude.

$$x = r \sin \phi \cos \theta$$

$$y = r \sin \phi \sin \theta$$

$$z = r \cos \phi$$

$$r^2 = x^2 + y^2 + z^2$$

$$\tan \phi = \frac{\sqrt{x^2 + y^2}}{z}$$

$$\tan \theta = \frac{y}{x}$$

# Cylindrical Coordinates

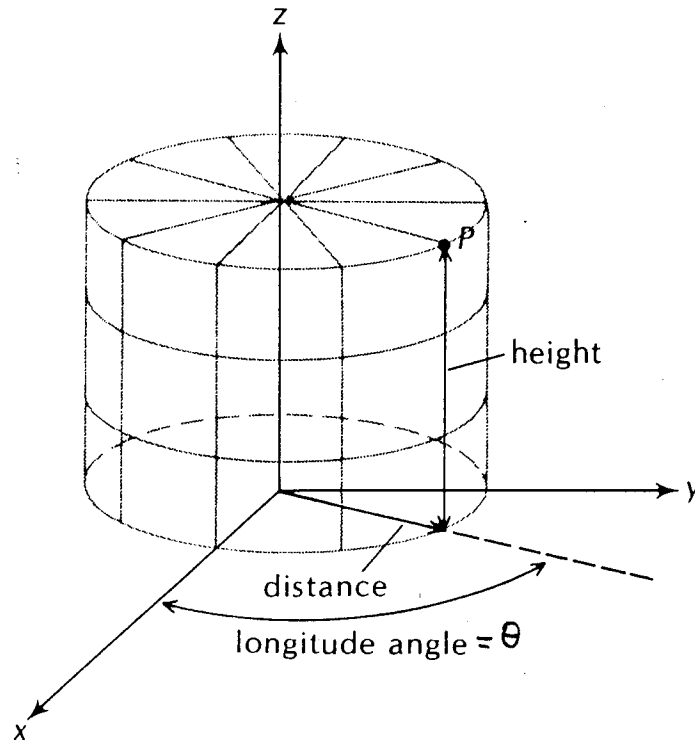

$r \rightarrow$  distance from cylindrical axis to point - P  
 $z \rightarrow$  height above the horizontal plane  
 $\theta \rightarrow$  angle in  $xy$ -plane measured from  $x$ -axis

$$x = r \cos \theta$$

$$y = r \sin \theta$$

$$z = z$$

$$r^2 = x^2 + y^2$$

$$\tan \theta = y/x$$

$$z = z$$

Space :

3-dimensional

Euclidean

- sum of angles in plane  $\Delta = 180^\circ$

} observation  
experimentsTime :Time is absolute !!

- the rate at which time elapses is independent of position and independent of velocity.

Euclidean Geometry  
+  
Absolute Time} Classical or Newtonian  
Physics

Isaac Newton : (1642-1727)

- Principia Mathematica (1687)
- For nearly 200 yrs these laws stood unchallenged as a basis for scientifically explaining the physical world.
- Today these laws are still the essential ingredients of engineering/physics.

- laws of Motion
- Universal Gravitation

## Shortcomings:

We know that the postulates of Space-Time are not exactly true.

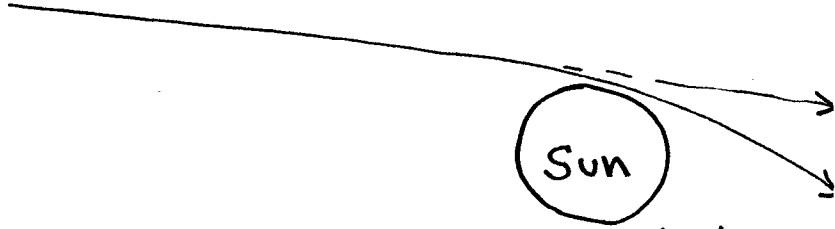

- Light rays passing by the sun are deflected  
- sum of angles in a  $\Delta \neq 180^\circ$ .
- Clocks moving at high velocity ( $v \sim c$ ) or which are in a gravitational field keep time at a different rate compared with clocks at rest.  
→ Time Dilation
- Neutron Stars :  $a = 10^{11}$  gees
- Black Holes : Even light is trapped.

New Theory :  $\left. \begin{array}{l} \text{Special Relativity} \\ \text{General Relativity} \end{array} \right\} \text{A. Einstein}$   
(space/time  $\rightarrow$  curved)

- Effects are very small for  $v \ll c$
- Play an undetectable role in the basic mechanics we will study.
- Elementary Particles : short distances, times,  $v \sim c$   
⇒ Quantum Mechanics.



## lengths

Farthest observed quasar (1987)  
 Wavelength of visible light  
 Radius of a proton

$2 \times 10^{26}$  m  
 $10^{-7}$  m  
 $10^{-15}$  m

## Time

lifetime of a proton (est.)  
 Age of universe  
 lifetime of most unstable particle  
 Planck time

$\sim 10^{39}$  s  
 $5 \times 10^{17}$  s  
 $\sim 10^{-23}$  s  
 $\sim 10^{-43}$  s

## Mass

Known universe  
 Elephant  
 Electron

$\sim 10^{53}$  kg  
 $5 \times 10^3$   
 $9 \times 10^{-31}$

Time:

Originally =  $\frac{1}{60 \times 60 \times 24}$  of a mean solar day.

- not very precise since there is a variation due to earth's rotation, etc.  
(winds, tides, air, glaciers)

Presently = Atomic Standard

1 second = 9,192,631,770 vibrations of a cesium atom

$\text{Cs-133} \Rightarrow$  cesium atomic clock  $\sim 10^{-10}$  NS.

Accuracy  $\sim 10^{-13} \Rightarrow$  1 s in 300,000 yrs.

Mass:

Standard : A cylinder of platinum-iridium alloy  
at BIPM (Paris)  
 $\equiv$  1 kg. exactly by definition

Atomic Standard

- None yet
- Possibly in future.

e.g. Hydrogen or Krypton atoms

- Some very large number would represent 1-kg.

## Relative Mass Measurements

- Nuclear reactions

$$^{12}\text{C} (\text{atom}) = 12 \text{ u} \quad (\text{exact}) \quad (\text{Atomic Mass Units})$$

- Other masses can be measured relative to carbon very precisely.

$$1 \text{ u} \sim 1.66054 \times 10^{-27} \text{ kg.}$$

## Derived Units

$$\text{Volume} = L^3 \quad (\text{m}^3)$$

$$\text{Density } \rho = \frac{M}{V} = \frac{\text{Mass}}{\text{Volume}} = \text{ML}^{-3} \quad (\text{kg/m}^3)$$

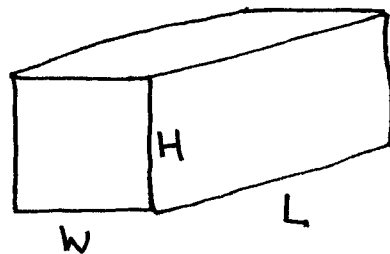

$$\text{Velocity} = \frac{\text{length}}{\text{Time}} = \text{LT}^{-1} \quad (\text{m/s})$$

## changing units

- Essential skill required for solving physics probs.
- "chain-link-Conversion"

$$s = 80 \text{ km/hr}$$

$$= ? \text{ m/s}$$

Know:  $1 \text{ hr} = 3600 \text{ s}$

$$\therefore 1 = \frac{1 \text{ hr}}{3600 \text{ s}}$$

Also  $1000 \text{ m} = 1 \text{ km}$

$$\therefore 1 = \frac{1 \text{ km}}{1000 \text{ m}}$$

$$s = \frac{80 \cancel{\text{ km}}}{\cancel{\text{ hr}}} \times \frac{1 \cancel{\text{ hr}}}{3600 \text{ s}} \times \frac{1}{\frac{\cancel{1 \text{ km}}}{1000 \text{ m}}}$$

$$= \frac{80 \times 1000}{3600} \text{ m/s} = 22 \text{ m/s}$$

• units obey same rules as algebraic variables and numbers!!

Powers of Ten: (10 min)

# Dimensional Analysis

1-16

- Dimensions refer to type of units  $[M, L, T]$  required to describe a physical process
- For beginners it is particularly useful to treat dimensions just like all other variables (quantities) in the calculation

$[ ] \Rightarrow$  dimensions

$$s = vt$$
$$[L] = \left[ \frac{L}{T} \right] [T] = [L]$$

- Scheme for working out relationships and basic dependences in physics.

## Rules:

- In an equation we can only add or subtract quantities which have the same dimension
- The quantities on each side of an equality must have the same dimension.

Example

Is this eq. correct:

$$v = v_0 + \frac{1}{2}at^2$$

$\uparrow$                      $\uparrow$                      $\uparrow$   
 Final                Initial                acceleration

$$\left[\frac{L}{T}\right] = \left[\frac{L}{T}\right] + \frac{1}{2} \left[\frac{L}{T^2}\right] [T^2] \quad \text{N.G.}$$

- Dimensions cannot check for constants such as  $\frac{1}{2}$ ,  $\pi$ , etc.

