

## YOUNG'S MODULUS

In this demo we measured the value of Young's modulus for a copper wire. The setup is shown in the figure (not to scale!).

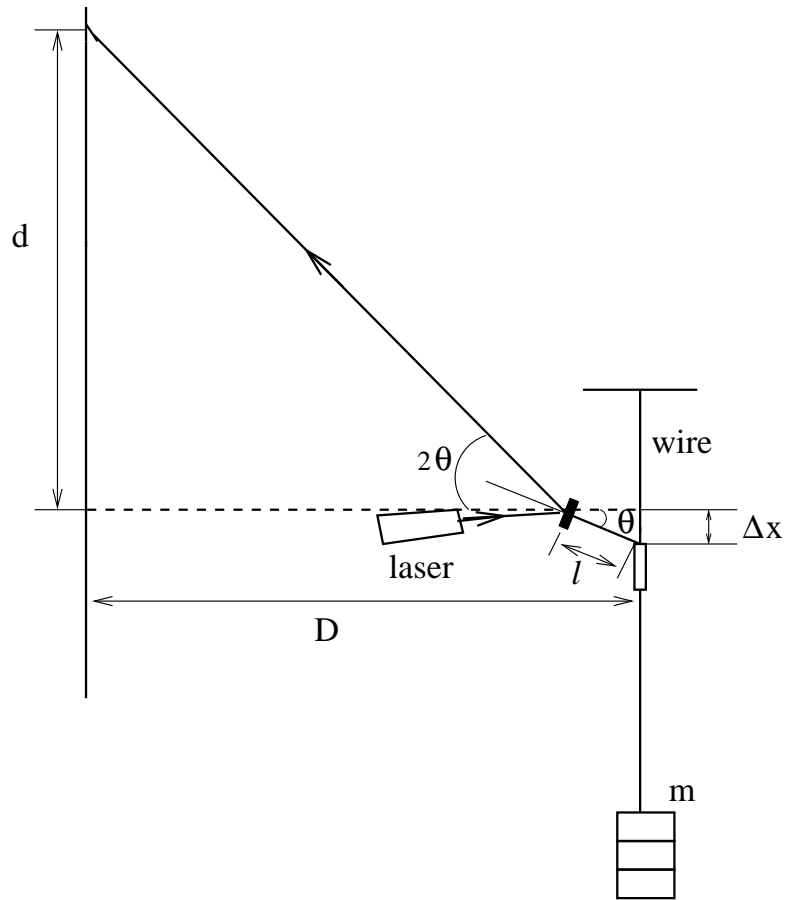

Young's modulus is defined as

$$Y = \frac{F_{\text{perp}}/A}{\Delta x/x} \quad (1)$$

If we hang a mass on the wire, then  $F_{\text{perp}}$  is the weight (it acts perpendicular to the cross-sectional area of the wire). We also know the length  $x$  of the wire. So, to measure  $Y$  we need to determine the extension  $\Delta x$  of the wire as a function of the weight. For small  $\Delta x$ , there should be a linear relation, and the constant of proportionality is the Young's modulus  $Y$ .

We know the weight from the number of masses placed on the holder at the end of the wire. The displacement is small, but can be "magnified" in order to measure it easily by arranging an apparatus such that the stretch of the wire tilts a mirror that a laser beam reflects off of. As you can see from the figure,  $\sin 2\theta = d/D$ , where  $D$  is the distance to the wall, and  $d$  is the distance from the horizontal to the laser spot. In the small angle approximation,  $\sin 2\theta \sim 2\theta$ . We also have that  $\Delta x = l \sin \theta \sim l\theta$ , where  $l$  is the length from the mirror to its pivot where the wire is tilting it. Putting these equations together, we get  $\Delta x = ld/2D$ , i.e. the displacement of the laser spot on the wall is proportional to the  $\Delta x$  of the wire.

Here are the displacements of the laser spot that Muyinatu measured as more weight was added to the holder at the bottom of the wire:

mass (kg)	$F_{\text{perp}}$ (N)	stress = $F_{\text{perp}}/A$ (N/m <sup>2</sup> )	d (cm)	strain= $\Delta x/x$
1.0	9.8	$3.00 \times 10^7$	0.	0.
1.5	13.7	$4.18 \times 10^7$	2.1	0.00018
2.0	19.6	$5.98 \times 10^7$	4.2	0.00037
2.5	24.5	$7.47 \times 10^7$	6.6	0.00058
3.0	29.4	$8.96 \times 10^7$	9.7	0.00085
3.5	34.3	$10.48 \times 10^7$	15.7	0.0014
4.0	39.2	$11.95 \times 10^7$	29.2	0.0025
5.0	49.0	$14.93 \times 10^7$	above top of board	
6.0	58.8	$17.93 \times 10^7$	on ceiling!	
9.0	88.2	$26.89 \times 10^7$	broke!!	

I've also calculated stress and strain, using the diameter of the wire 0.646 mm,  $l = 7.7$  cm,  $D=11$  m, and  $x=40$  cm.

The next plot shows stress versus strain. You can see clearly that it goes non-linear at a stress of about  $9 \times 10^7$  N/m<sup>2</sup>.

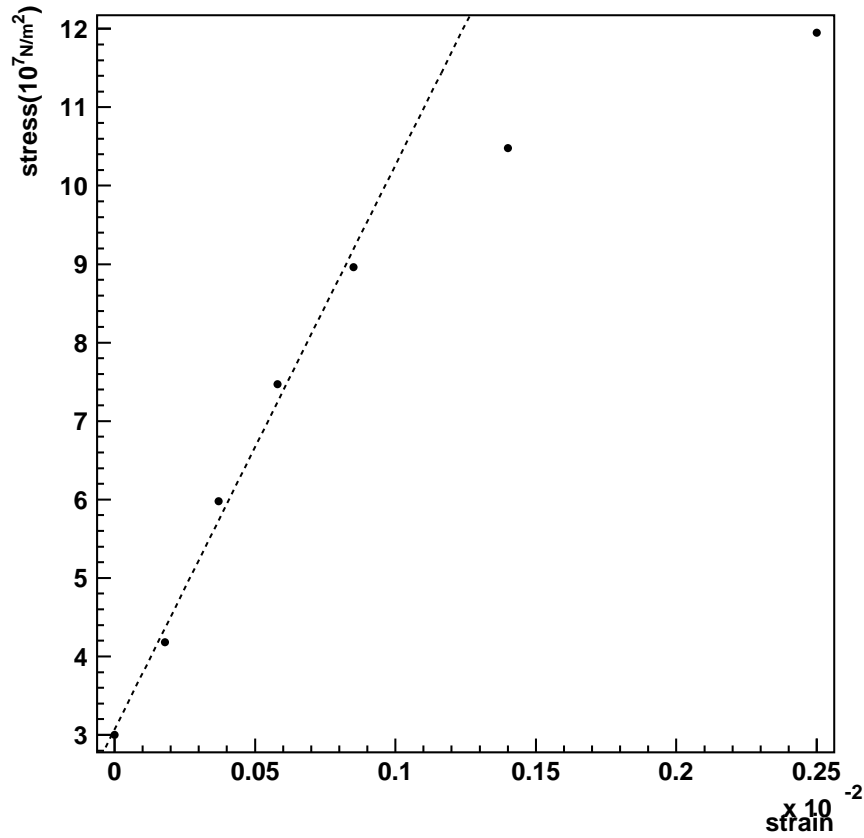

From the slope in the linear regime, the Young's modulus of this wire is  $7 \times 10^{10}$  N/m<sup>2</sup>. The tensile strength of the wire is roughly the stress at the breaking point, or  $2.7 \times 10^8$  N/m<sup>2</sup>.