

Massachusetts Institute of Technology
 Department of Physics
 Physics 8.022 – Fall 2003
 Quiz#2

- Total points in the quiz are 100. **ALL** problems receive **equal** points (25 each). Work on problems you are more comfortable with **first!**
- This is a closed book and closed notes exam. An equations table is given to you below.
- No programmable, plotting, integration/differentiation capable calculators are allowed.

Currents, Magnetism and Relativity Formulae

Capacitance: $Q = CV$, (energy) $U = \frac{1}{2}CV^2$

Capacitor networks: Parallel: $C = C_1 + C_2$, series: $\frac{1}{C} = \frac{1}{C_1} + \frac{1}{C_2}$

Currents: $I = \frac{dq}{dt}$, $I = \int_S \vec{J} \cdot d\vec{a}$

Conservation Law/Continuity: $\vec{\nabla} \cdot \vec{J} = -\frac{\partial \rho}{\partial t}$

Ohm's Law: $\vec{J} = \sigma \vec{E}$, $V = IR$

Resistor networks: Series: $R = R_1 + R_2$, parallel: $\frac{1}{R} = \frac{1}{R_1} + \frac{1}{R_2}$

Magnetic charges: $\vec{\nabla} \cdot \vec{B} = 0$

Biot-Savart's Law: $d\vec{B} = \frac{Id\vec{l} \times \hat{r}}{cr^2}$

Lorentz Force: $\vec{F} = q\vec{E} + \frac{q}{c}\vec{v} \times \vec{B}$

Force on current: $\vec{F} = I d\vec{l} \times \vec{B}$

Ampere's Law: $\oint_C \vec{B} \cdot d\vec{l} = \frac{4\pi}{c} I_{encl} = \frac{4\pi}{c} \int_S \vec{J} \cdot d\vec{a}$, $\vec{\nabla} \times \vec{B} = \frac{4\pi}{c} \vec{J}$

Relativistic Transformations:

All primed quantities measured in the frame F' which is moving in the positive x direction with velocity $u = \beta c$ as seen from F :

$$\begin{aligned} x' &= \gamma(x - \beta ct) & p' &= \gamma(p - \beta \frac{E}{c}) \\ t' &= \gamma(t - \beta \frac{x}{c}) & E' &= \gamma(E - \beta cp) \\ E'_x &= E_x & E'_y &= \gamma(E_y - \beta B_z) & E'_z &= \gamma(E_z + \beta B_y) \\ B'_x &= B_x & B'_y &= \gamma(B_y + \beta E_z) & B'_z &= \gamma(B_z - \beta E_y) \end{aligned}$$

Relativistic Mass, Energy: $m = \gamma m_0$, $E = mc^2$

Gradient: in cartesian $\vec{\nabla} f = \frac{\partial f}{\partial x} \hat{x} + \frac{\partial f}{\partial y} \hat{y} + \frac{\partial f}{\partial z} \hat{z}$, in cylindrical $\vec{\nabla} f = \frac{\partial f}{\partial \rho} \hat{\rho} + \frac{1}{\rho} \frac{\partial f}{\partial \phi} \hat{\phi} + \frac{\partial f}{\partial z} \hat{z}$, in spherical $\vec{\nabla} f = \frac{\partial f}{\partial r} \hat{r} + \frac{1}{r} \frac{\partial f}{\partial \theta} \hat{\theta} + \frac{1}{r \sin \theta} \frac{\partial f}{\partial \phi} \hat{\phi}$

Divergence: in cartesian $\vec{\nabla} \cdot \vec{F} = \frac{\partial F_x}{\partial x} + \frac{\partial F_y}{\partial y} + \frac{\partial F_z}{\partial z}$, in cylindrical $\vec{\nabla} \cdot \vec{F} = \frac{F_\rho}{\rho} + \frac{\partial F_\rho}{\partial \rho} + \frac{1}{\rho} \frac{\partial F_\phi}{\partial \phi} + \frac{\partial F_z}{\partial z}$, in spherical $\vec{\nabla} \cdot \vec{F} = \frac{2F_r}{r} + \frac{\partial F_r}{\partial r} + \frac{F_\theta}{r} \cot \theta + \frac{1}{r} \frac{\partial F_\theta}{\partial \theta} + \frac{1}{r \sin \theta} \frac{\partial F_\phi}{\partial \phi}$

(25 points) Problem 1

A battery E with internal resistance r , two resistors $R_1 = 10r$ and $R_2 = 5r$ and two capacitors C_1 and C_2 with $C_1 = 2C_2$ are arranged as shown in the figure below. The capacitors are initially uncharged. Express all your answers in terms of E, r and C_2 .

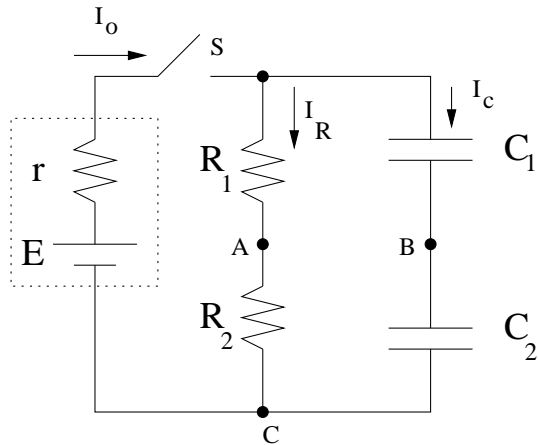

- (a) At $t = 0$ the switch S is closed. What is the potential at A with respect to C (i.e., $V_{AC} = V_A - V_C$) and what is the potential at B with respect to C (i.e., $V_{BC} = V_B - V_C$)?
- (b) After infinite time has elapsed (and with the switch S remaining closed) what is $V_{AC} = V_A - V_C$ and $V_{BC} = V_B - V_C$?
- (c) Write down a set of independent equations that will yield the solutions for the currents flowing in the three branches of the circuit, i.e., $I_0(t), I_R(t), I_C(t)$. Do NOT solve them.

We now short-circuit points A and B of the circuit by connecting them with a resistanceless conducting wire:

- (d) Will there be any current flowing through it (yes/no) and in what direction?
- (e) What will be the final $V_{AC} = V_A - V_C$ and $V_{BC} = V_B - V_C$?
- (f) What is the total charge that flew through the short-circuiting wire? Is this consistent with your answer in (d)?

(25 points) Problem 2

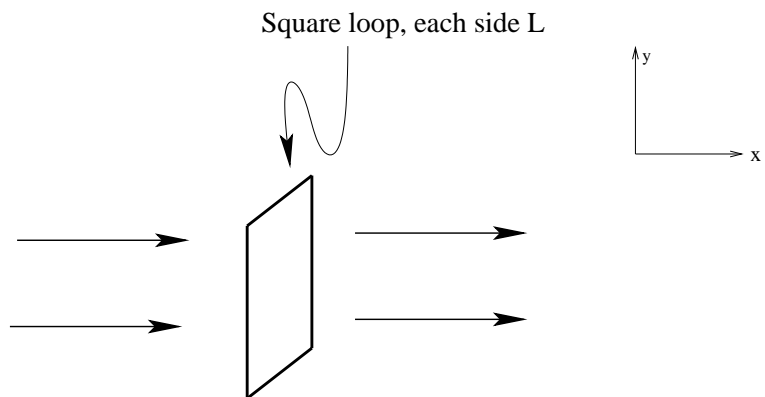

In this problem, we will figure out how conductivity transforms between frames of reference.

A laboratory is filled with a material whose conductivity is σ . An electric field of magnitude E points in the x direction. This causes a current to flow normal to a square loop with sides of length l .

- (a) In an interval of time Δt , how much charge Δq flows through the loop?

This laboratory is now placed on a large train that is moving in the x direction with very large velocity v . An interval of time Δt passes on the train. We observe all of this as the train goes past us.

(b) During the “train time” interval Δt , what time interval $\Delta t'$ passes according to us? What area A' do we observe? How much charge $\Delta q'$ passes through the loop in this interval?

(c) Using the results of part (b), compute the current density J' we see.

(d) Using the result of part (c) plus the rule for transforming electric fields, compute the conductivity σ' that we measure.

The lab is now taken off the train and placed on an elevator which climbs upward, in the y direction, with the same very large velocity v . An interval of time Δt passes on the elevator. We observe the lab go past us while standing next to the elevator doors.

(e) During the “elevator time” interval Δt , what time interval $\Delta t'$ passes according to us? What area A' do we observe? How much charge $\Delta q'$ passes through the loop in this interval?

(f) Using the results of part (e), compute the current density J' we see.

(g) Using the result of part (f) plus the rule for transforming electric fields, compute the conductivity σ' that we measure. Does it agree with your result for part (d)? Should it?

(25 points) Problem 3

A coaxial cable consists of a solid inner conductor of radius R_1 and an outer concentric cylindrical tube of inner radius R_2 and outer radius R_3 . The two conductors carry equal and opposite currents I_0 which however are not uniformly distributed across their cross sections, instead, their current densities J vary linearly with distance from the center, i.e., $J_1 = C_1 r$ for the inner one and $J_2 = C_2 r$ for the outer one (where C_1 and C_2 are constants). Find the magnetic field at a distance r from the axis of the cable for (a) $r < R_1$ (b) $R_1 < r < R_2$ (c) $R_2 < r < R_3$ and (d) $r > R_3$. Express all your answers in terms of I_0, R_1, R_2 and R_3 .

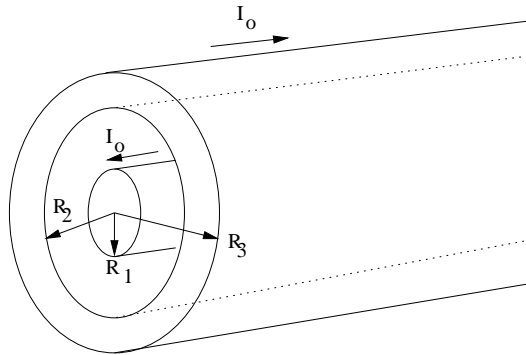

(25 points) Problem 4

A conducting ring of radius R is connected to two exterior wires ending at the two ends of a diameter as shown in the figure. The external wires are straight and a current I flows through them. The current splits into unequal portions while passing through the ring as shown in the figure. What is the \vec{B} field (magnitude and direction) at the center of the ring?

