

November 17, 2011

Massachusetts Institute of Technology

Department of Physics - Physics 8.09 - Fall 2011

Exam II

General comments

- This is a 'closed-book' exam. No books, notes or other reference material may be used except the attached equation sheet.
- The exam has three problems.
- Budget your time carefully!
- Good luck!

Problem 1 (20 points)

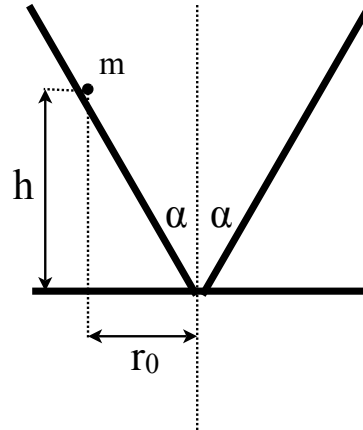

Consider a point mass m inside a cone with an opening angle 2α as shown above. The point mass experiences the impact of a uniform gravitational field. The height at which circular motion occurs is given by h .

- (4 points) Determine the Lagrange function.
 - (2 points) Determine the radial equation of motion in terms of only r , g , m , α as well as potentially conserved quantities.
 - (4 points) Determine the radius r_0 for circular motion in terms of g , m , α as well as potentially conserved quantities.
 - (2 points) Determine the angular velocity ω_0 for circular motion in terms of g , h and α .
 - (4 points) Consider now a small perturbation of circular motion r' , i.e. $r = r_0 + r'$, giving rise to a small change of the radius r_0 . Formulate the radial equation of motion in terms of r' .
 - (2 points) Determine now the angular velocity for these oscillations around r_0 in terms of g , h and α .
 - (2 points) Formulate a condition for closed orbital motion on both the angular velocity for circular motion and the angular velocity of small perturbations around r_0 .
- Hint: The solution does not require an elaborate calculation. Use your results from part d) and f).

Problem 2 (20 points)

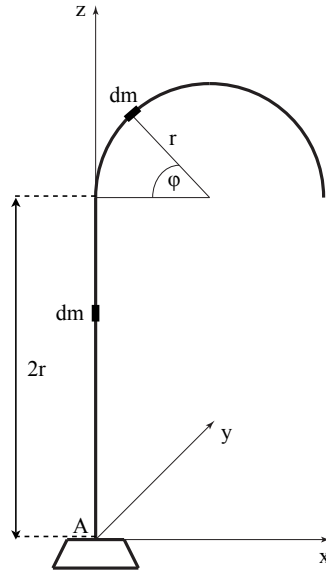

A pole as shown above is bent at the end and is rotating around its straight section with a non-uniform angular velocity ω . The z -axis of the body system (x, y, z) coincides with the z_I axis of the inertial system (x_I, y_I, z_I) . The straight section has a length of $2r$. The bent section has a radius of r . The bent pole has a uniform mass density per unit length of λ . The total mass of this arrangement is given by m .

- (2 points) Determine the mass of the straight section and bent section separately as a function of m .
- (4 points) Determine the moment of inertia tensor of the bent pole arrangement as shown above.
- (4 points) Determine the principal moments of the moment of inertia tensor.
Hint: To simplify the calculation you can use for this step an approximation of $\pi \approx 3!$
- (2 points) Determine the angular momentum in the body system.
- (4 points) Determine the torque in the body system.
- (4 points) Determine the torque in the inertial system.

Problem 3 (10 points)

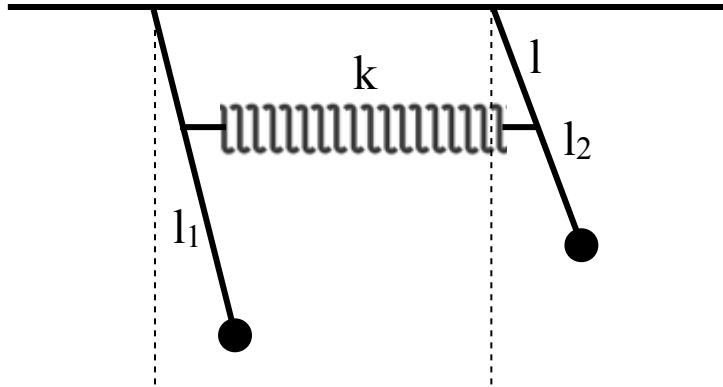

Consider a coupled pendulum configuration as shown above with two pendulums of length l_1 and l_2 and masses m_1 and m_2 . Assume that the spring of spring constant k is always horizontal, i.e. the length of the spring is much larger than the length l , which denotes the distance from the connection point of each pendulum to the connection point of the spring to each pendulum.

- (2 points) Determine the Lagrange function of this coupled pendulum system.
- (2 points) Determine the equations of motion.
- (4 points) Determine the normal mode frequencies.
- (2 points) Determine the normal mode frequencies for the special case of $l_1 = l_2$.

Equation sheet

- Moment of inertia tensor: $I_{ij} = \int \rho(x_1, x_2, x_3) [x_k x_k \delta_{ij} - x_i x_j] dV$
- Small angle approximation ($\theta \simeq 0$): $\sin \theta \simeq \theta$ and $\cos \theta \simeq 1$