

PROBLEM SET 1

DUE DATE: Thursday, September 22, 2005

READING ASSIGNMENT: *The First Three Minutes*, Chapters 1, 2, and 3.

PROBLEM 1: NONRELATIVISTIC DOPPLER SHIFT, SOURCE AND OBSERVER IN MOTION

Consider the Doppler shift of sound waves, for a case in which both the source and the observer are moving. Suppose the source is moving with a speed v_s relative to the air, while the observer is receding from the source, moving in the opposite direction with speed v_o relative to the air. Calculate the Doppler shift z .

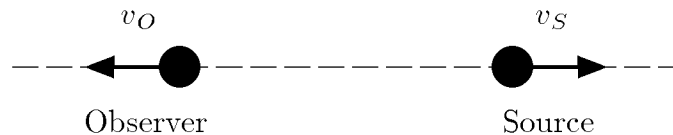

PROBLEM 2: THE TRANSVERSE DOPPLER SHIFT

Consider the Doppler shift observed by a stationary observer, from a source that travels in a circular orbit of radius R about the observer. Let the speed of the source be v_s .

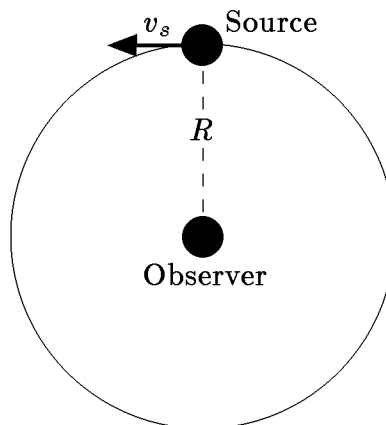

- (a) If the wave in question is sound, and both the source speed v_s and the wave speed u are very small compared to the speed of light c , what is the Doppler shift z ?

(b) If the wave is light, traveling with speed c , and v_s is not necessarily small compared to c , what is the Doppler shift z ? In answering this part of the question, you will want to keep in mind the following facts from special relativity:

- (1) TIME DILATION: Any clock which is moving at speed v relative to a given reference frame will appear (to an observer using that reference frame) to run slower than normal by a factor denoted by the Greek letter γ (gamma), and given by

$$\gamma \equiv \frac{1}{\sqrt{1 - \beta^2}}, \quad \beta \equiv v/c .$$

- (2) LORENTZ-FITZGERALD CONTRACTION: Any rod which is moving at a speed v along its length relative to a given reference frame will appear (to an observer using that reference frame) to be shorter than its normal length by the same factor γ . A rod which is moving perpendicular to its length does not undergo a change in apparent length.



- (3) RELATIVITY OF SIMULTANEITY: Suppose a rod which has rest length ℓ_0 is equipped with a clock at each end. The clocks can be synchronized in the rest frame of the system by using light pulses. If the system moves at speed v along its length, then the trailing clock will appear to read a time which is later than the leading clock by an amount $\beta\ell_0/c$. If, on the other hand, the system moves perpendicular to its length, then the synchronization of the clocks is not disturbed.

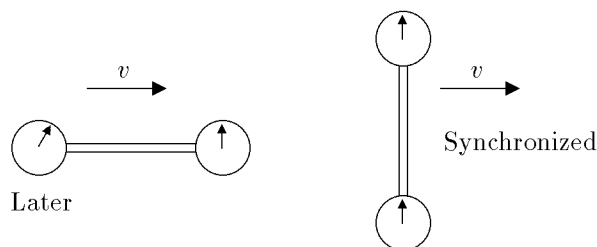

INTRODUCTION TO REMAINDER OF PROBLEM SET

In the rest of this problem set we will consider a universe in which the scale factor is given by

$$R(t) = bt^{2/3} ,$$

where b is an arbitrary constant of proportionality which should not appear in the answers to any of the questions below. (We will see in Lecture Notes 4 that this is the behavior of a flat universe with a mass density that is dominated by nonrelativistic matter.) We will suppose that a distant quasar is observed with a redshift z . As a concrete example we will consider the most distant known object with a well-determined redshift, the galaxy J132418.3 +271455, which has a redshift $z = 6.58$. The discovery of this galaxy was announced in January 2003 by Kodaira et al. of the Subaru Deep Field project.* The ability of astronomers to observe objects at high redshift has been increasing rapidly. In 1986 the object of highest known redshift was only 3.78. It was 4.01 in 1988, 4.73 in 1992, 4.897 in 1994, and 4.92 in 1998, 5.34 in 2000, and 6.28 in 2002. The discovery of a $z = 6.68$ galaxy was announced in 1999, but the measurement of the redshift was later found to be unreliable.

PROBLEM 3: DISTANCE TO THE GALAXY

Let t_0 denote the present time, and let t_e denote the time at which the light that we are currently receiving was emitted by the galaxy. In terms of these quantities, find the present value of the physical distance ℓ_p between this distant galaxy and us.

PROBLEM 4: TIME OF EMISSION

Express the redshift z in terms of t_0 and t_e . Find the ratio t_e/t_0 for the $z = 6.58$ galaxy.

PROBLEM 5: DISTANCE IN TERMS OF REDSHIFT z

Express the present value of the physical distance in terms of the present value of the Hubble constant H_0 and the redshift z . Taking $H_0 \approx 72 \text{ km-sec}^{-1}\text{-Mpc}^{-1}$, how far away is the galaxy? Express your answer both in light-years and in Mpc.

* K. Kodaira et al., Publ. Astron. Soc. Japan 55, L17–L21 (2003), also available as <http://arXiv.org/abs/astro-ph/0301096>.

PROBLEM 6: SPEED OF RECESSION

Find the rate at which the physical distance ℓ_p between the distant galaxy and us is changing. Express your answer in terms of the redshift z and the speed of light c , and evaluate it numerically for the case $z = 6.58$. Express your answer as a fraction of the speed of light. [If you get it right, this “fraction” is greater than one! Our expanding universe violates special relativity, but is consistent with general relativity.]

PROBLEM 7: APPARENT ANGULAR SIZES

Now suppose for simplicity that the galaxy is spherical, and that its physical diameter was w at the time it emitted the light. (The actual galaxy is seen as an unresolved point source, so we don't know its actual size and shape.) Find the apparent angular size θ (measured from one edge to the other) of the galaxy as it would be observed from Earth today. Express your answer in terms of w , z , H_0 , and c . You may assume that $\theta \ll 1$. Compare your answer to the apparent angular size of a circle of diameter w in a static Euclidean space, at a distance equal to the present value of the physical distance to the galaxy, as found in Problem 3. [Hint: draw diagrams which trace the light rays in the **comoving** coordinate system. If you have it right, you will find that θ has a minimum value for $z = 1.25$, and that θ increases for larger z . This phenomenon makes sense if you think about the distance to the galaxy at the time of emission. If the galaxy is **very** far away today, then the light that we now see must have left the object very early, when it was rather close to us!]

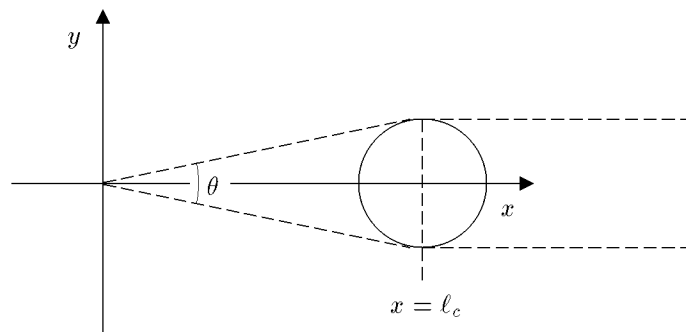

PROBLEM 8: RECEIVED RADIATION FLUX

At the time of emission, the galaxy had a power output P (measured, say, in ergs/sec) which was radiated uniformly in all directions. This power was emitted in the form of photons. What is the radiation energy flux J from this galaxy at the earth today? Energy flux (which might be measured in $\text{ergs}\cdot\text{cm}^{-2}\cdot\text{sec}^{-1}$) is defined as the energy per unit area per unit time striking a surface that is orthogonal to the direction of energy flow. The easiest way to solve this problem is to consider the trajectories of the photons, as viewed in comoving coordinates. You must calculate the rate at which photons arrive at the detector, and you must also use the fact that the energy of each photon is proportional to its frequency, and is therefore decreased by the redshift. You may find it useful to think of the detector as a small part of a sphere that is centered on the source, as shown in the following diagram:

