

MASSACHUSETTS INSTITUTE OF TECHNOLOGY  
Physics Department

Physics 8.286: The Early Universe  
Prof. Alan Guth

September 11, 2007

## PROBLEM SET 2

**DUE DATE:** Tuesday, September 18, 2007

**READING ASSIGNMENT:** Barbara Ryden, *Introduction to Cosmology*,  
Chapters 1-3.

**PROBLEM POINT CREDIT:** In Problem Set 1 each problem was worth 5 points. For this problem set the number of points per problem varies, depending on how much work I expect the problem to involve.

### INTRODUCTION TO THE PROBLEM SET

In this problem set we will consider a universe in which the scale factor is given by

$$R(t) = bt^{2/3} ,$$

where  $b$  is an arbitrary constant of proportionality which should not appear in the answers to any of the questions below. (We will see in Lecture Notes 4 that this is the behavior of a flat universe with a mass density that is dominated by nonrelativistic matter.) We will suppose that a distant galaxy is observed with a redshift  $z$ . As a concrete example we will consider the most distant known object with a well-determined redshift, the galaxy J132418.3 +271455, which has a redshift  $z = 6.58$ . The discovery of this galaxy was announced in January 2003 by Kodaira et al. of the Subaru Deep Field project.\* The ability of astronomers to observe objects at high redshift has been increasing rapidly. In 1986 the object of highest known redshift was only 3.78. It was 4.01 in 1988, 4.73 in 1992, 4.897 in 1994, and 4.92 in 1998, 5.34 in 2000, and 6.28 in 2002. The discovery of a  $z = 6.68$  galaxy was announced in 1999, but the measurement of the redshift was later found to be unreliable. The search for high redshift objects continues to be an exciting area of research, as astronomers try to sort out the conditions in the universe when the

---

\* K. Kodaira et al., Publ. Astron. Soc. Japan 55, L17–L21 (2003), also available as <http://arXiv.org/abs/astro-ph/0301096>.

first galaxies began to form.†

**PROBLEM 1: DISTANCE TO THE GALAXY** (5 points)

Let  $t_0$  denote the present time, and let  $t_e$  denote the time at which the light that we are currently receiving was emitted by the galaxy. In terms of these quantities, find the present value of the physical distance  $\ell_p$  between this distant galaxy and us.

**PROBLEM 2: TIME OF EMISSION** (5 points)

Express the redshift  $z$  in terms of  $t_0$  and  $t_e$ . Find the ratio  $t_e/t_0$  for the  $z = 6.58$  galaxy.

---

† Note on High Redshift Searches: The  $z=6.58$  redshift was measured by spectroscopy, identifying individual lines and comparing them with their wavelengths as observed on Earth. When sources are very weak, astronomers sometimes measure redshifts “photometrically,” which means that broad features of the spectrum are determined by measuring the light that comes through a range of filters. Galaxies have been seen with photometrically determined redshifts as high as 7 [1,2]. There was also a report of a spectroscopically determined redshift of 10.0 in a galaxy that was highly magnified by gravitational lensing [3]. This measurement, however, was based on only one spectral line, and the result has been refuted by other astronomers [4,5]. More recently have found a number of similar candidate objects in the range of  $8.5 < z < 10.4$ , but these results still need to be confirmed [6]. Until recently the highest known redshifts were always quasars, but this hegemony was ended with the  $z=6.58$  redshift galaxy discovered in 2003. Today the highest measured redshift for a quasar is 6.43 [7]. (Special thanks to Hsiao-Wen Chen and Paul Schechter for helping me put together this note.)

1. Kneib, J., et al., “A Probable  $z \sim 7$  Galaxy Strongly Lensed by the Rich Cluster A2218: Exploring the Dark Ages,” *The Astrophysical Journal* (2004), v. 607, Issue 2, pp. 697-703.

2. Egami, E., et al., “Spitzer and Hubble Space Telescope Constraints on the Physical Properties of the  $z \sim 7$  Galaxy Strongly Lensed by A2218,” *The Astrophysical Journal* (2005), v. 618, Issue 1, pp. L5-L8.

3. Pello et al., “ISAAC/VLT observations of a lensed galaxy at  $z = 10.0$ ,” *Astronomy and Astrophysics* (2004), v. 416, p. L35.

4. S.J. Weatherly et al., “Reanalysis of the spectrum of the  $z = 10$  galaxy,” *Astron. Astrophys.*, vol. 428 (2004), p. L29, arXiv:astro-ph/0407150v3

5. M.N. Bremer et al., “Gemini H-band imaging of the field of a  $z = 10$  candidate,” *Astrophys. J.*, vol. 615 (2004), pp. L1-L4, arXiv:astro-ph/0409485.

6. Stark, D. et al., “A Keck survey for gravitationally lensed Ly $\alpha$  emitters in the redshift range  $8.5 < z < 10.4$ : New constraints on the contribution of low-luminosity sources to cosmic reionization,” *The Astrophysical Journal* (2007), v. 663, pp. 10-28.

7. Fan, Xiahoui et al., “A Survey of  $z > 5.7$  Quasars in the Sloan Digital Sky Survey. II. Discovery of Three Additional Quasars at  $z > 6$ ,” *The Astronomical Journal* (2003), v. 125, Issue 4, pp. 1649-1659.

**PROBLEM 3: DISTANCE IN TERMS OF REDSHIFT  $z$**  (5 points)

Express the present value of the physical distance in terms of the present value of the Hubble constant  $H_0$  and the redshift  $z$ . Taking  $H_0 \approx 72 \text{ km-sec}^{-1}\text{-Mpc}^{-1}$ , how far away is the galaxy? Express your answer both in light-years and in Mpc.

**PROBLEM 4: SPEED OF RECESSION** (5 points)

Find the rate at which the physical distance  $\ell_p$  between the distant galaxy and us is changing. Express your answer in terms of the redshift  $z$  and the speed of light  $c$ , and evaluate it numerically for the case  $z = 6.58$ . Express your answer as a fraction of the speed of light. [If you get it right, this “fraction” is greater than one! Our expanding universe violates special relativity, but is consistent with general relativity.]

**PROBLEM 5: APPARENT ANGULAR SIZES** (10 points)

Now suppose for simplicity that the galaxy is spherical, and that its physical diameter was  $w$  at the time it emitted the light. (The actual galaxy is seen as an unresolved point source, so we don't know its actual size and shape.) Find the apparent angular size  $\theta$  (measured from one edge to the other) of the galaxy as it would be observed from Earth today. Express your answer in terms of  $w$ ,  $z$ ,  $H_0$ , and  $c$ . You may assume that  $\theta \ll 1$ . Compare your answer to the apparent angular size of a circle of diameter  $w$  in a static Euclidean space, at a distance equal to the present value of the physical distance to the galaxy, as found in Problem 1. [Hint: draw diagrams which trace the light rays in the **comoving** coordinate system. If you have it right, you will find that  $\theta$  has a minimum value for  $z = 1.25$ , and that  $\theta$  increases for larger  $z$ . This phenomenon makes sense if you think about the distance to the galaxy at the time of emission. If the galaxy is **very** far away today, then the light that we now see must have left the object very early, when it was rather close to us!]

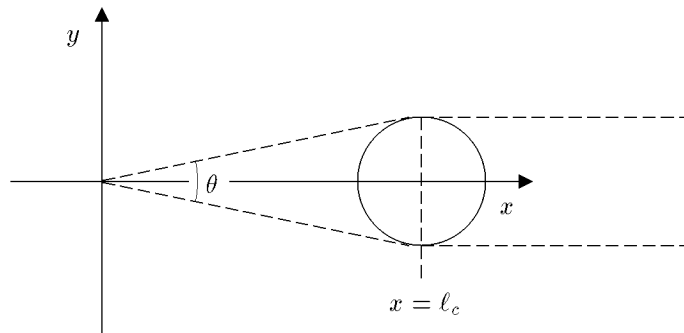

**PROBLEM 6: RECEIVED RADIATION FLUX** (10 points)

At the time of emission, the galaxy had a power output  $P$  (measured, say, in ergs/sec) which was radiated uniformly in all directions. This power was emitted in the form of photons. What is the radiation energy flux  $J$  from this galaxy at the earth today? Energy flux (which might be measured in  $\text{ergs}\cdot\text{cm}^{-2}\cdot\text{sec}^{-1}$ ) is defined as the energy per unit area per unit time striking a surface that is orthogonal to the direction of energy flow. The easiest way to solve this problem is to consider the trajectories of the photons, as viewed in comoving coordinates. You must calculate the rate at which photons arrive at the detector, and you must also use the fact that the energy of each photon is proportional to its frequency, and is therefore decreased by the redshift. You may find it useful to think of the detector as a small part of a sphere that is centered on the source, as shown in the following diagram:

