



STRONGARM

Challenge 6 – Enhanced Breaching Tool

M. Spencer, A. Muth, J. Getachew, S. Felton, B. Manley

DESIGN CONCEPT

- **Pneumatically powered** ramming head provides power without weight
- Internal air tank holds pressure for multiple firings with low downtime
- On-board air pump allows repressurizing in field
- Dual-point safety prevents accidental firing

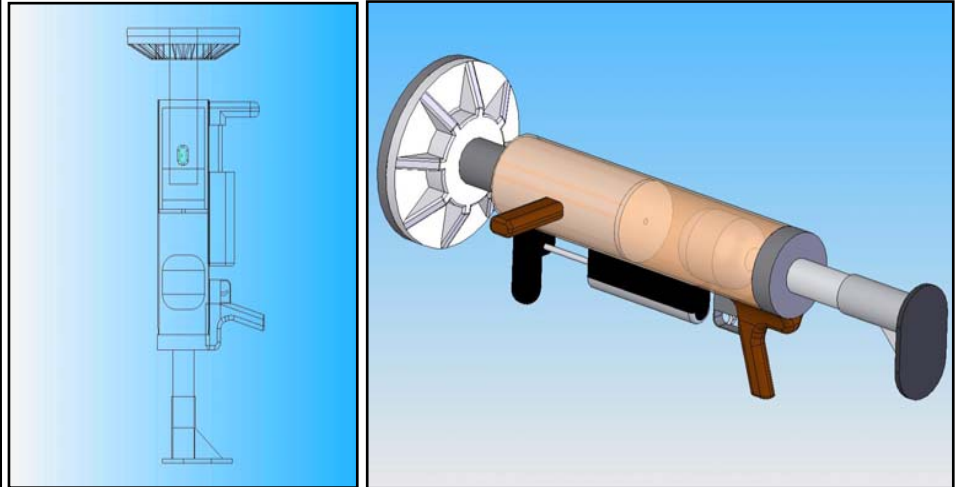

DESIGN HIGHLIGHTS

- Lightweight yet powerful
- Rapid reload time
- Multiple shots per refill of air tank
- Small size for use in MOUT situations
- No supply chain for ammunition or batteries needed
- Safe for indefinite storage
- Adjustable for 5-95% compatibility

SOLDIER BENEFITS

- Powered ram lets soldier open doors quickly without firing live rounds
- Lightweight system prevents soldier fatigue from carrying heavy battering ram
- Multi-shot tank guarantees door breach
- Rapid reload time eliminates downtime between breaches
- Low noise for use at night, in urban areas