

# Heating of Olympus Target Cell

---

## Frank Brinker

I tried to collect and document here some of the phenomena connected with the intense heating of the Olympus target cell. I use archived data from the runs and pictures taken by Jan Bernauer as well as my own observations. This collection is surely not complete and should be complemented by other observation, calculations etc.

## Observations during operation

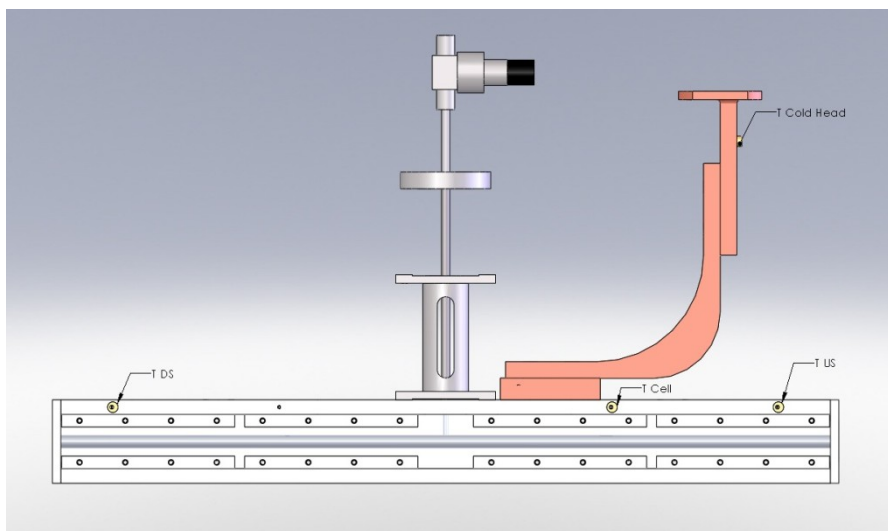

Figure 1: Positions of temperature sensors

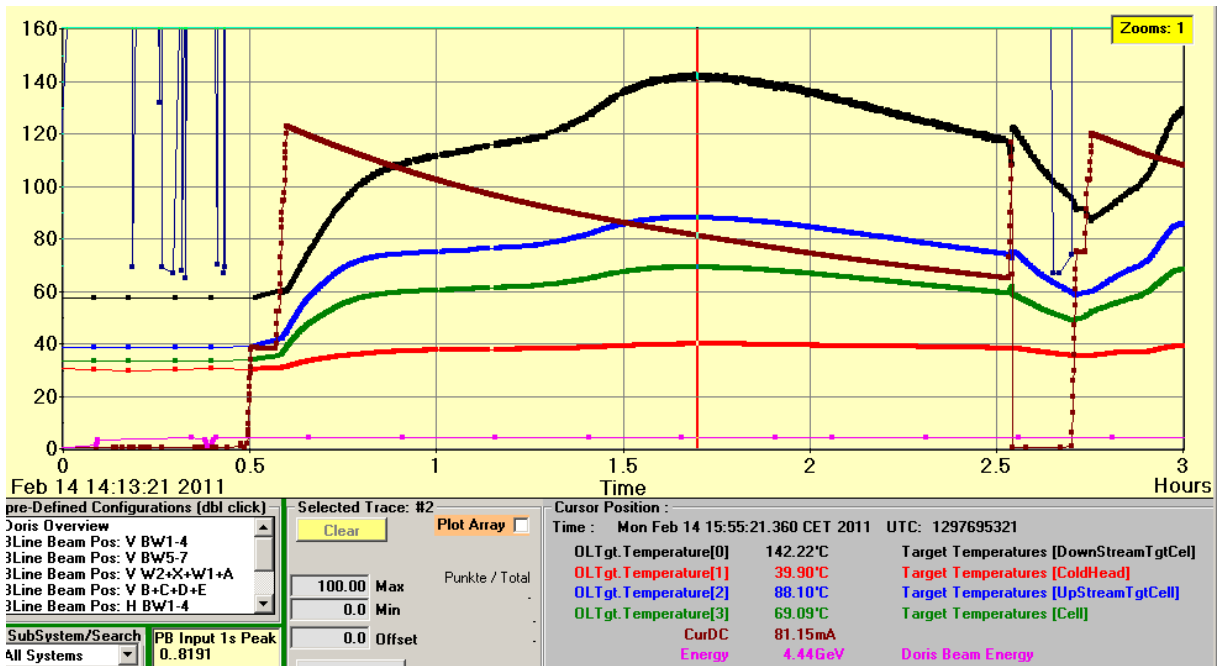

Figure 2: Temperatures at sensors, 10 Bunches 120 mA max., beam oscillations until 1.3 hours

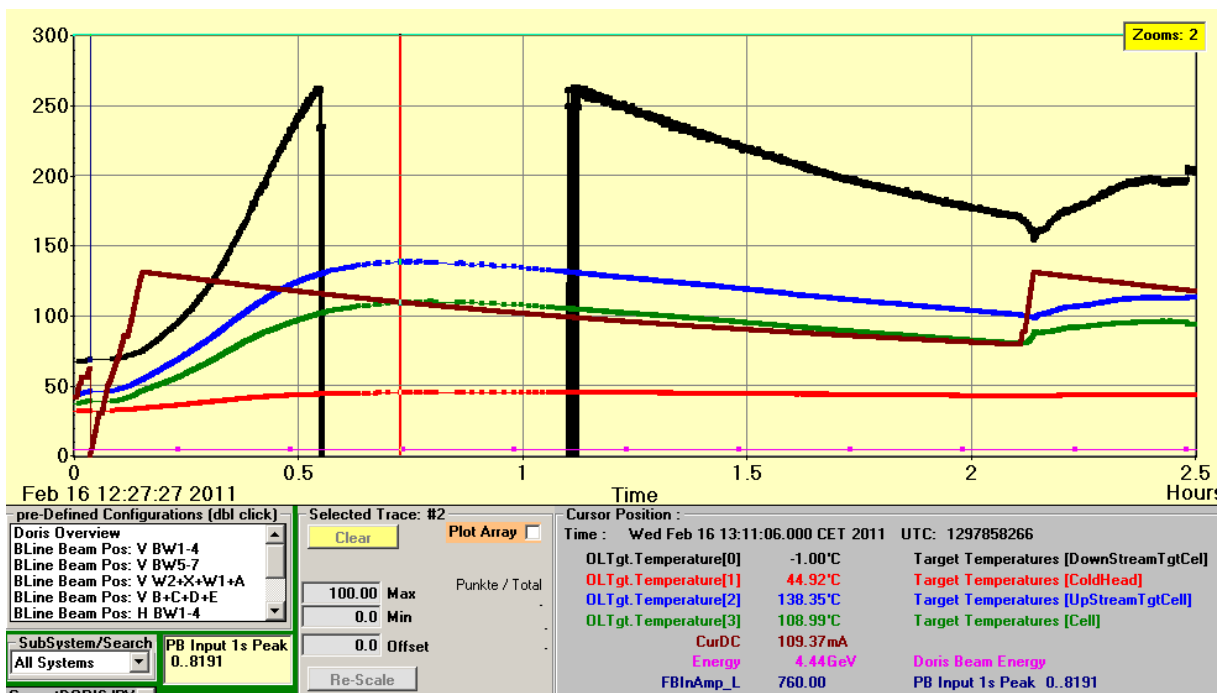

Figure 3: Temperatures for 130 mA, 10 Bunches, 4.4 GeV, w/o oscillations

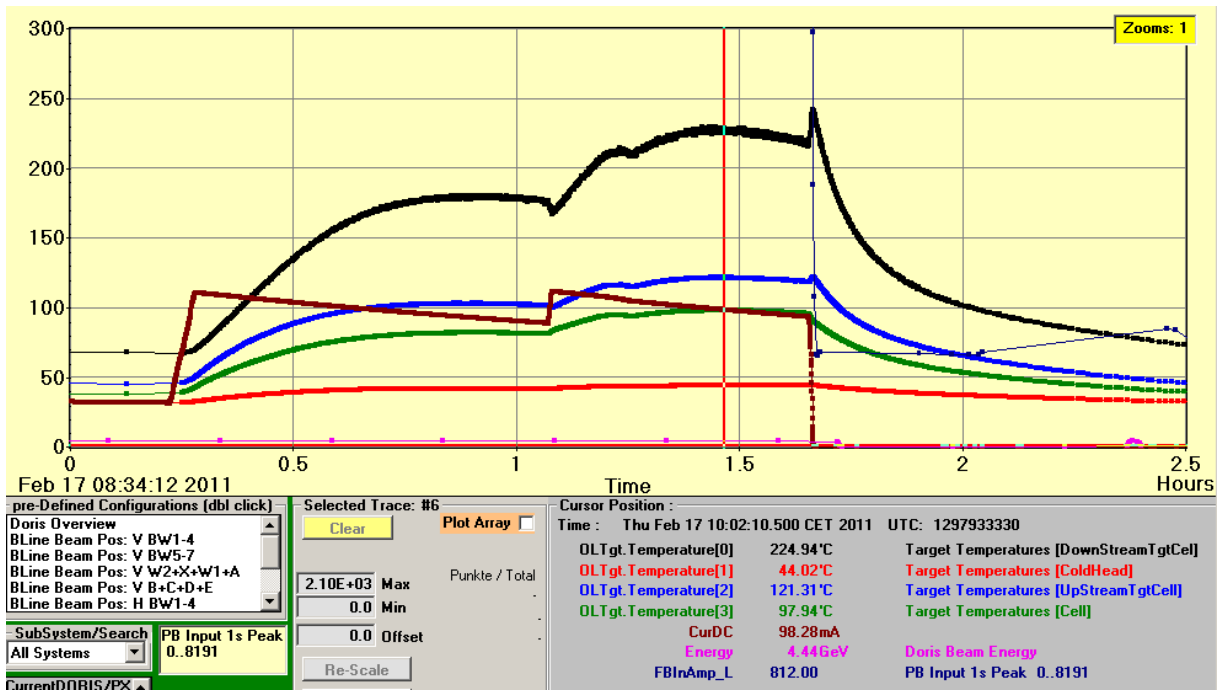

Figure 4: Temperatures, 2 consecutive runs with  $I_{max}=110$  mA, 10 Bunches, 4.4 GeV, no oscillations

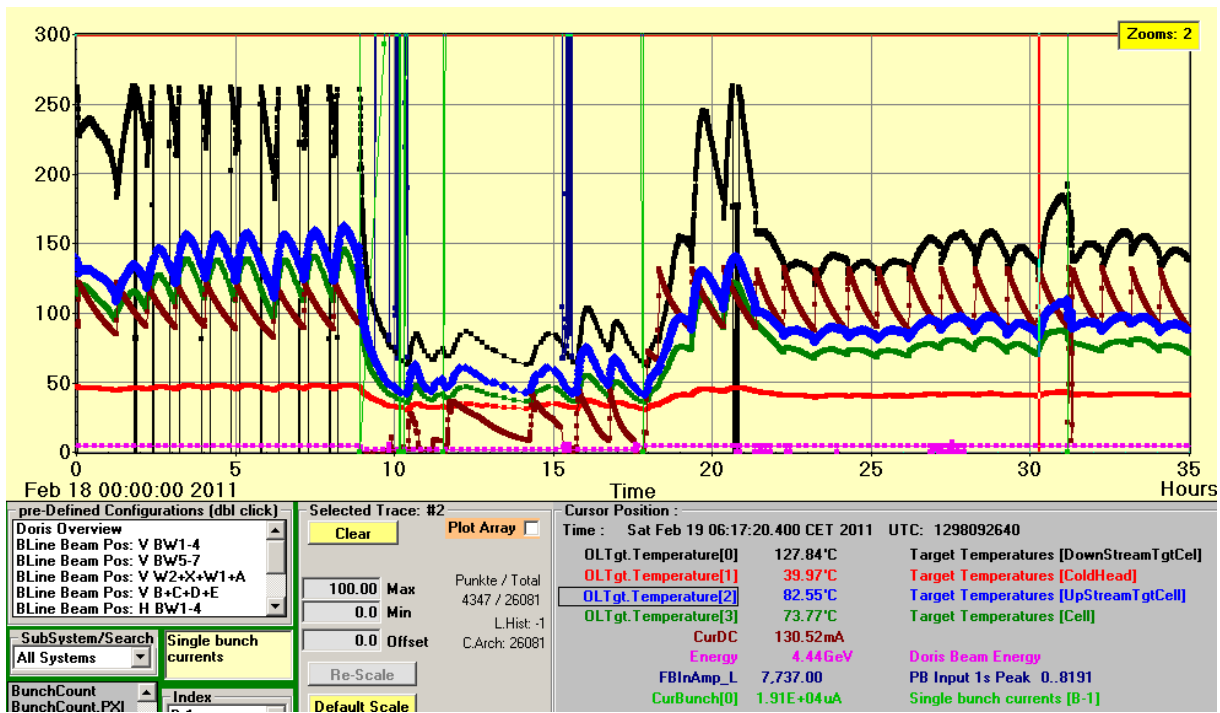

Figure 5: Temp., 10 Bunches, 130 mA, 4.4 GeV, w/o oscillations up to 22 hours and with oscillations afterwards. Low current runs were with 2 GeV. The one run at 31 h had 19mA filled in the first bunch instead of 13mA.



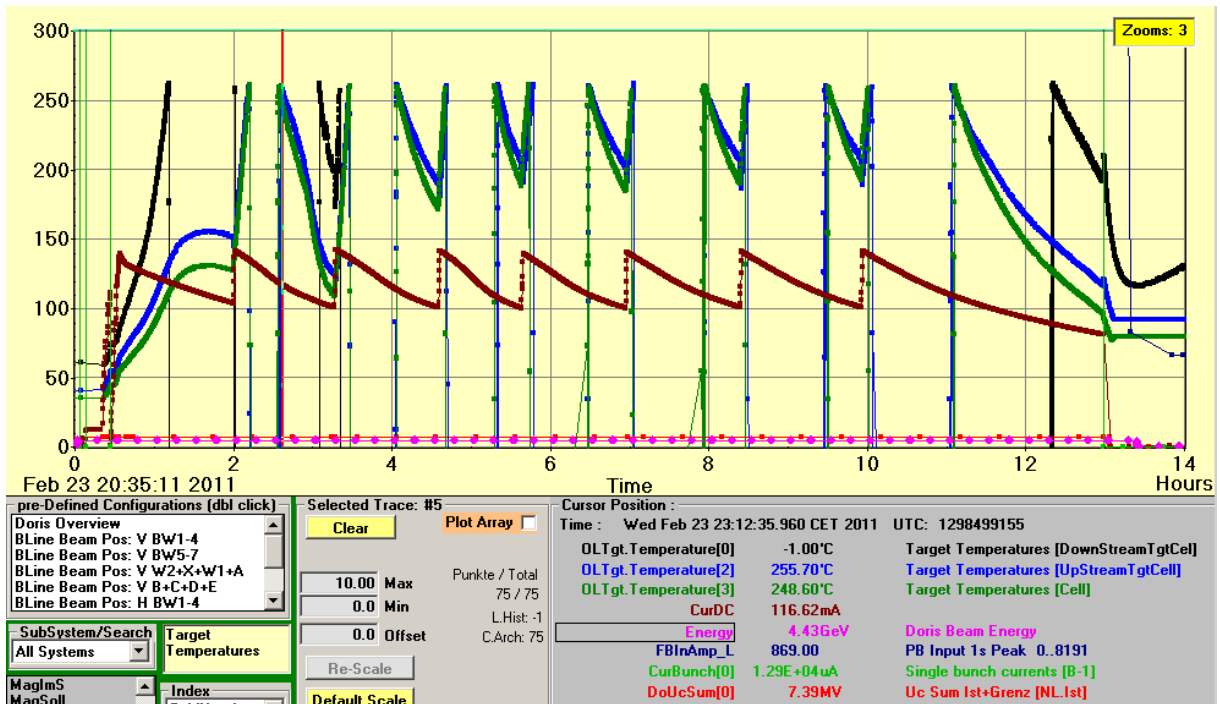

Figure 8: Temp. during the last night. 140mA in 10 Bunches at 4.4 GeV w/o oscillations.

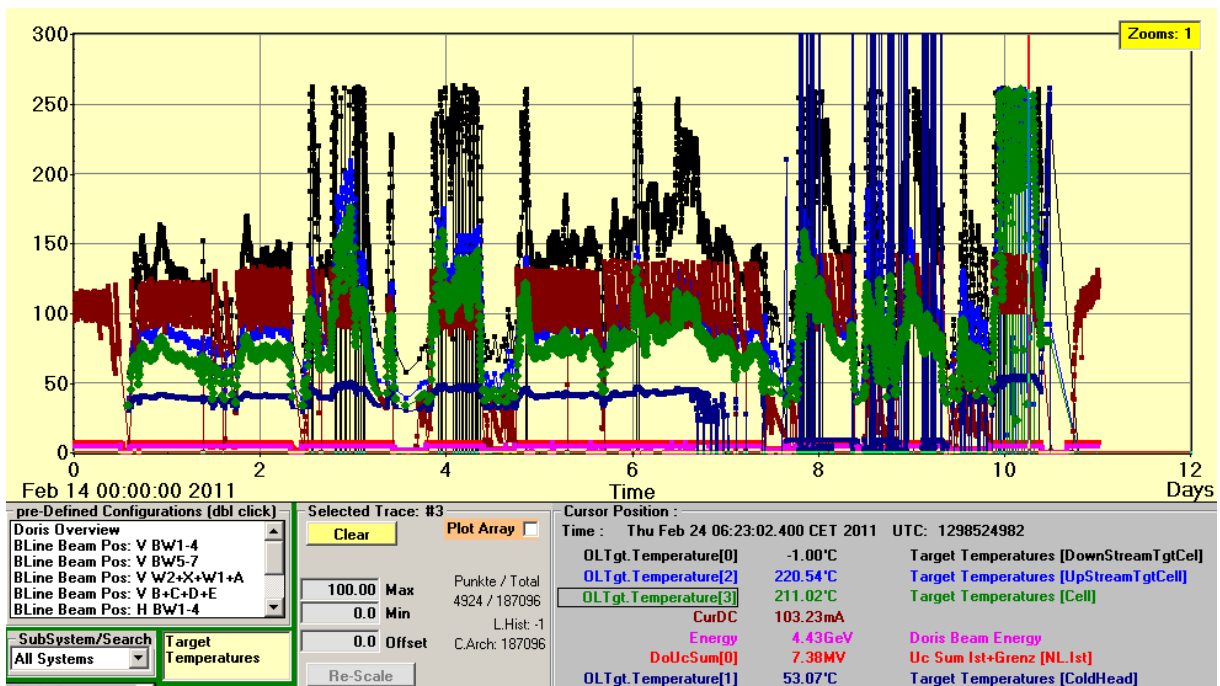

Figure 9: Temp. from Feb 14th until 24th with a sudden increase during the night Feb 23rd.

Some qualitative observations U-C is the temperature difference Upstream – Cell and D-C Downstream-Cell:

1. In Figure 5 one sees the influence of longitudinal beam oscillations on the temperatures. The difference U-C is nearly constant (~20K) whereas the difference D-C more than doubles from 60-70K to ~140K when the oscillations vanish. D-C is about 7 times U-C!

2. In Figure 6 the situation with shorter bunches at 2.0 GeV is documented. The peak current is only 70 mA nevertheless the temperatures reach values similar than 110 mA at 4.5 GeV. But D-C is only 3 times U-C in this case.
3. The temperatures are significantly reduced for longer bunches if the RF-Voltage is reduced from 3.4 MV to 2.3 MV in Figure 7. The Upstream temp. is about 100 K instead of 150 K at an even somewhat higher maximum current. The bunch length should be a factor 1.2 longer since its inverse proportional to the square root of  $U_c$ .
4. During the last night the peak current was 140 mA instead of 135 mA and the minimal current was 100mA instead of 90 mA. At the same time the temperatures were about a factor 2 higher, but the different U-C remained at about 20K.

**Observations at the transitions between the parts of the target chamber with pictures after removal of chamber on February 24<sup>th</sup> and opening of the chamber on March 10<sup>th</sup>.**

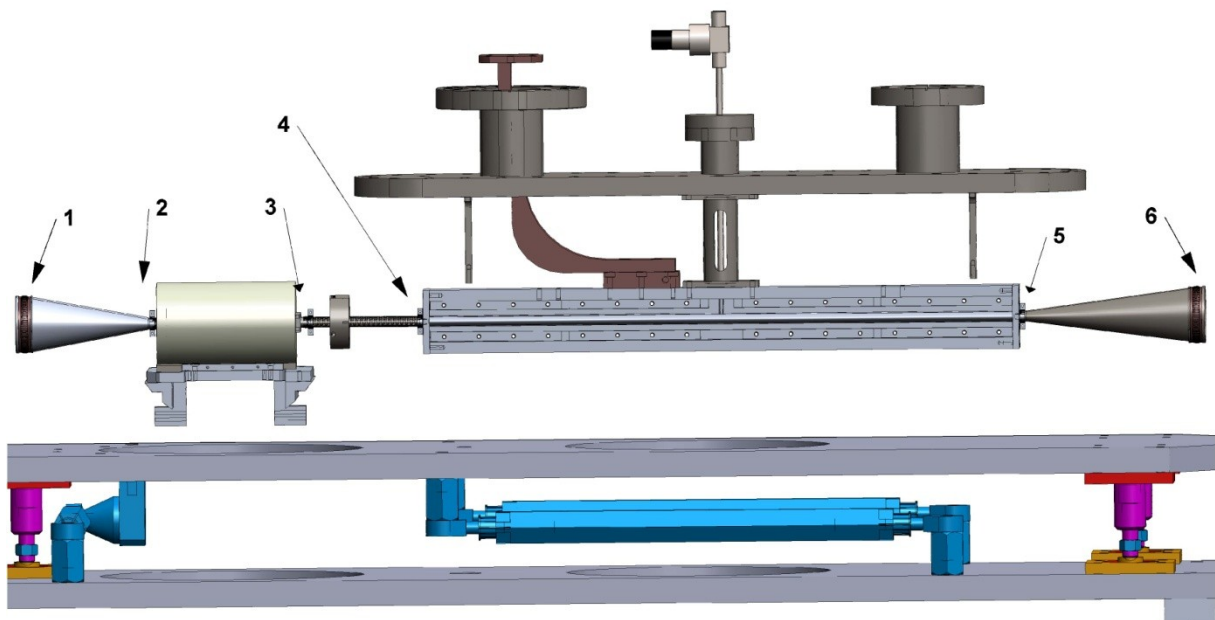

Figure 10: The six transitions between different parts of the target chamber

## Transitions 1+2, connection between the tapered cones and the tubes of the target chamber

These cones have a circular shape at the outer ends which fit into the tubes at both ends of the target chamber. At the end the cones have a ring with springs to assure a good electric contact. These junctions are rigid, show no damage at all and we believe that they worked as expected.

## Transition 2, from cone to collimator on upstream side

From Figure 11 and Figure 12 one can see that the connection is intact but one recognizes also some small steps and bumps at the end of the cone and at the transition to the end ring. Figure 14 shows this connection from the outside. One can recognize that the aluminum cone is welded(?) at some (4-5) points to the ring which supports the RF-fingers. The image current of the beam has to find its way over these connections. These details surely increase the distortions of the wake fields.

On the target wall facing the collimator colored regions on top and bottom of this transition can be seen. Nothing similar can be seen on the opposite side on the collimator.

In this region energy is deposited by three effects.

1. RF heating. The fields from the bunches see the change of cross section, the resistance of the wall and the distortions from steps, holes etc.
2. Synchrotron radiation. The radiation from the last bending magnet which is 32m away has still a power of 20W/cm ( integrated over the vertical ) at 4.5 GeV beam energy and a current of 140mA independent of the bunch number. If the synchrotron fan is centered it will hit the outer side of the cone in the midplane with 20-30W in total. It might as well happen that the beam leaves the last dipole with a vertical angle – in this case the fan might hit the top or bottom side of the cone on the outside half with about 60W in total. About 75% of the power would be lost in the aluminum cone, the rest would be absorbed in the collimator.
3. Beam particles dumped in the collimator. During injection and beam storage it's practically excluded to hit this part of the cone with a significant fraction of the beam. I would not exclude for now that the beam might be dumped here at beam losses. The beam has an energy of about 600 J and would pass the aluminum and be stopped in the collimator.

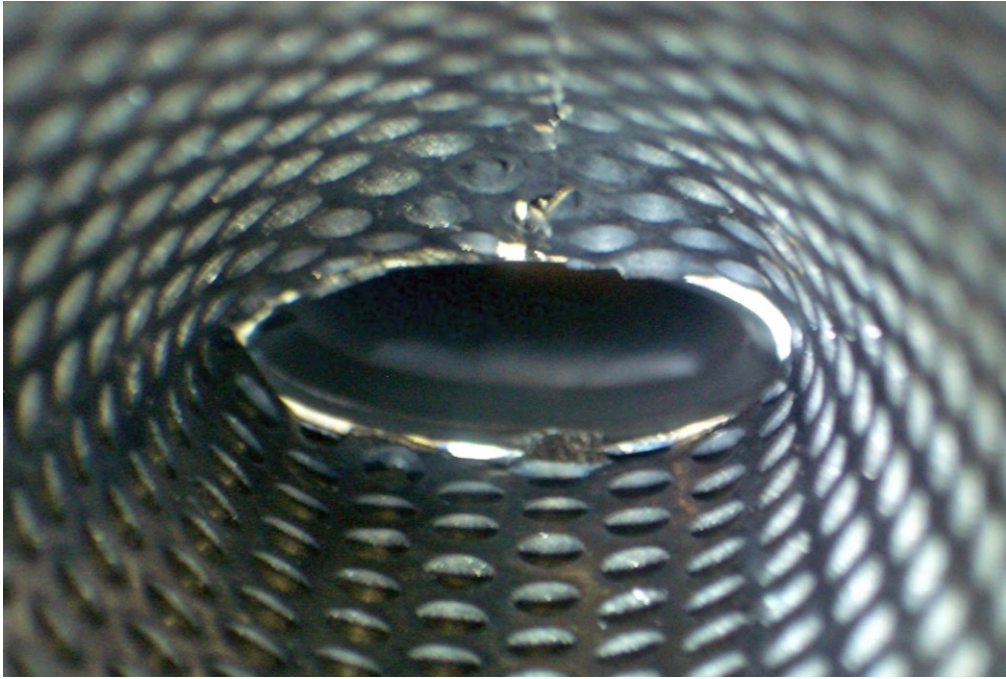

Figure 11: View from the upstream side before opening the chamber

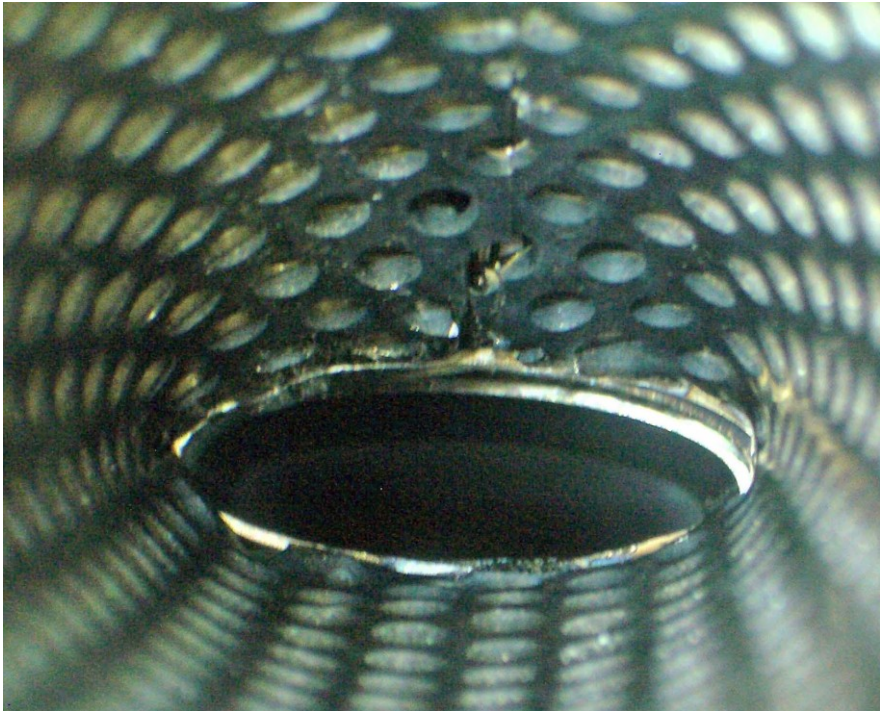

Figure 12: same as before, but under a different angle

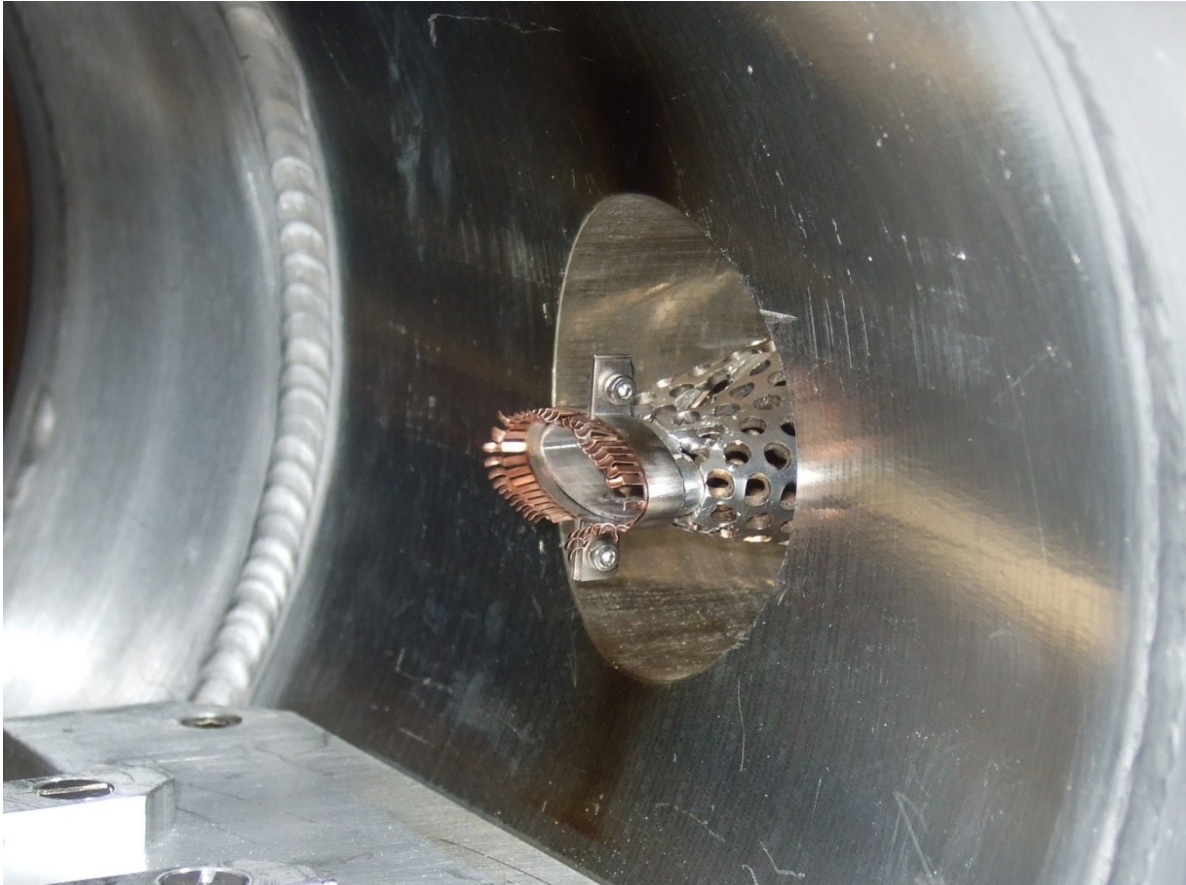

Figure 13: End of wake field suppressor which was connected to the collimator. On top and bottom side colors can be seen which stem probably from a thin layer of metal. The damage of the springs on the side are probably caused by the removal of the collimator.

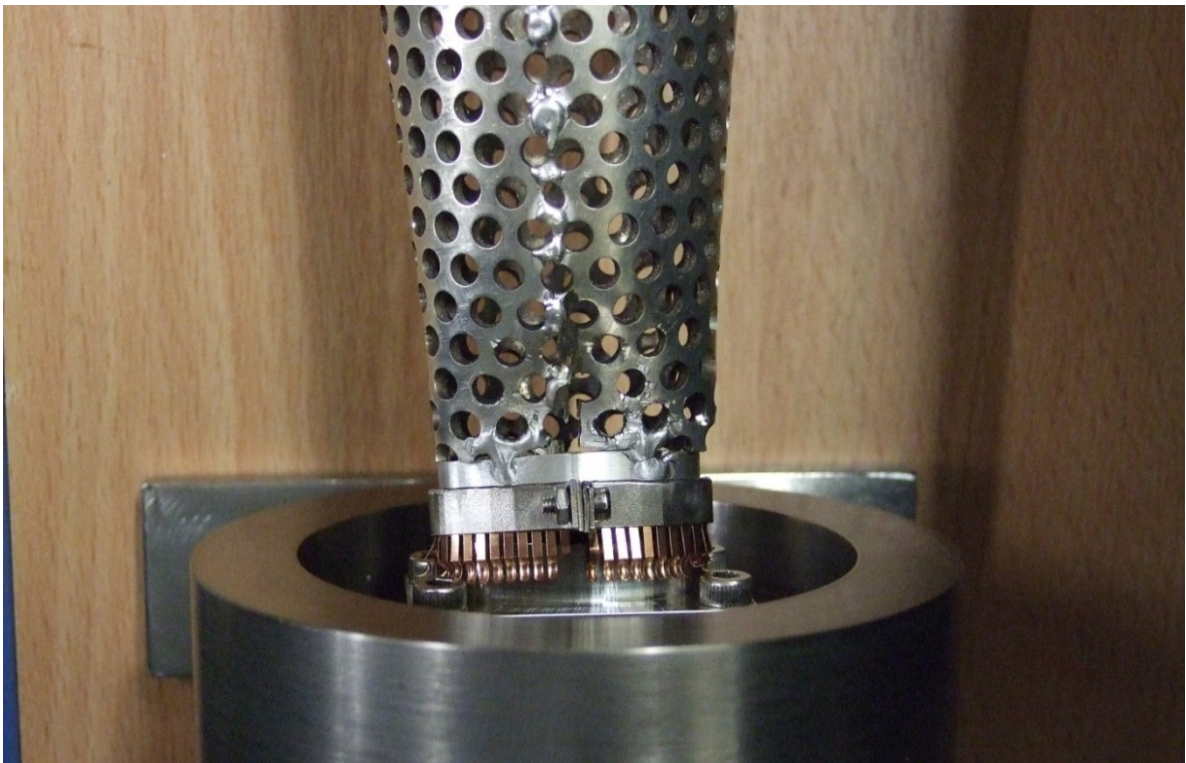

Figure 14: View on the upstream end of the collimator. The damage on the fingers happened during the disassembly. One can see the two welding spots and the larger hole on the top.

### **Transition 3 from collimator to wake field suppressor**

There are no pictures from this part, it's not visible from the outside. There are no hints of damages here.

### **Transition 4 from wake field suppressor to target cell**

High temperatures appeared in this region as can be seen by the melted insulation in Figure 15. The wake field suppressor looks fine as well as the RF-Fingers. But the support ring lost its contact to the cell foil at least on the upper half. The welding spots are broken and left small holes in the aluminum foil of the cell.

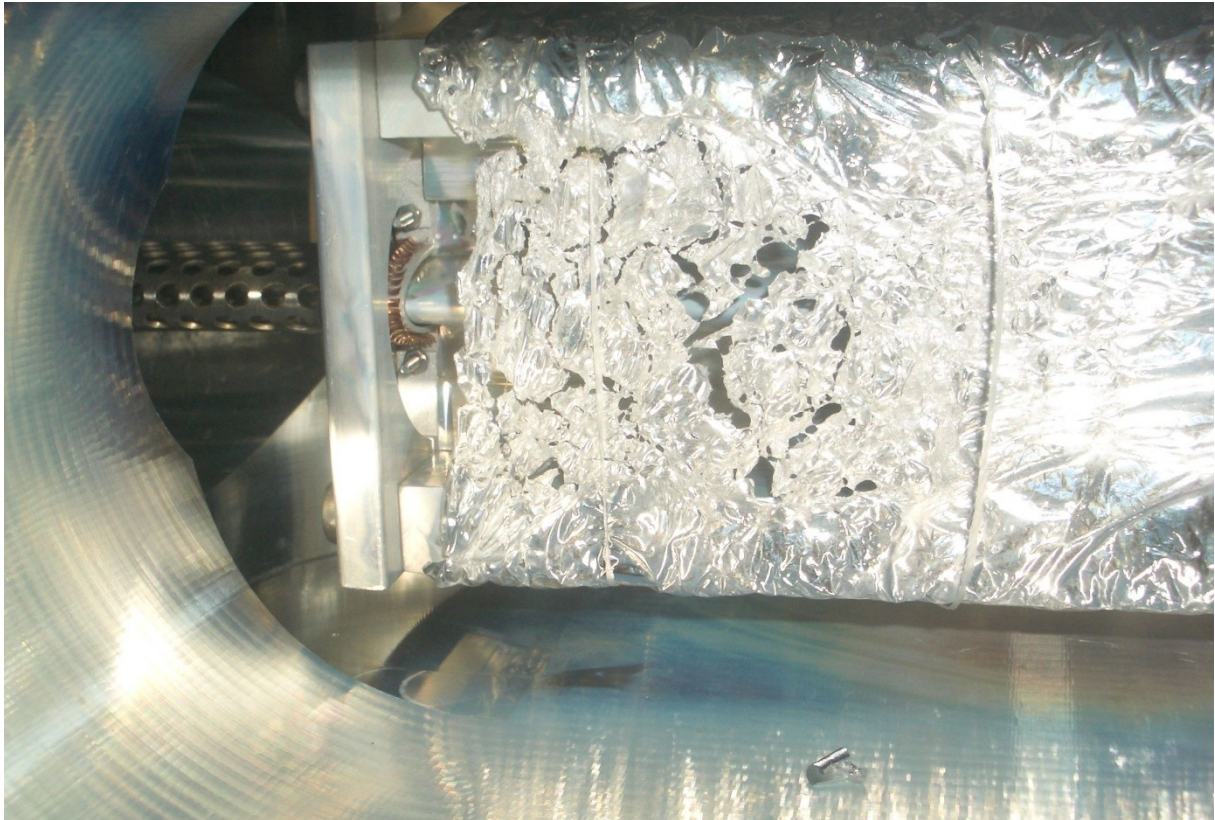

**Figure 15: Insulation at upstream end of cell after runs.**

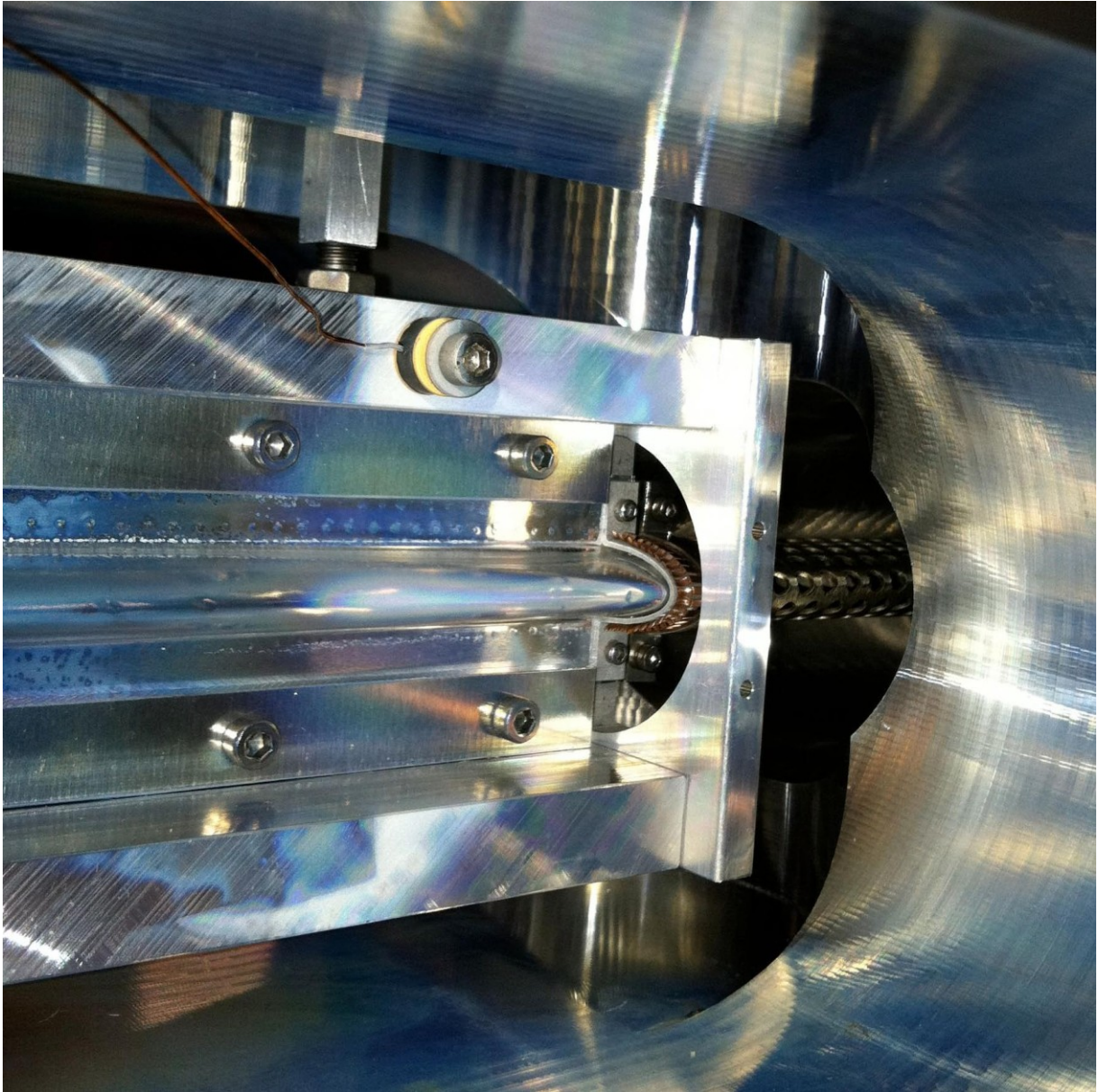

Figure 16: Upstream end of cell. The transition from collimator to cell looks fine as well as the RF-fingers. But it seems that the cell does not have a direct contact to the support ring.



Figure 17: Detail of the previous picture.

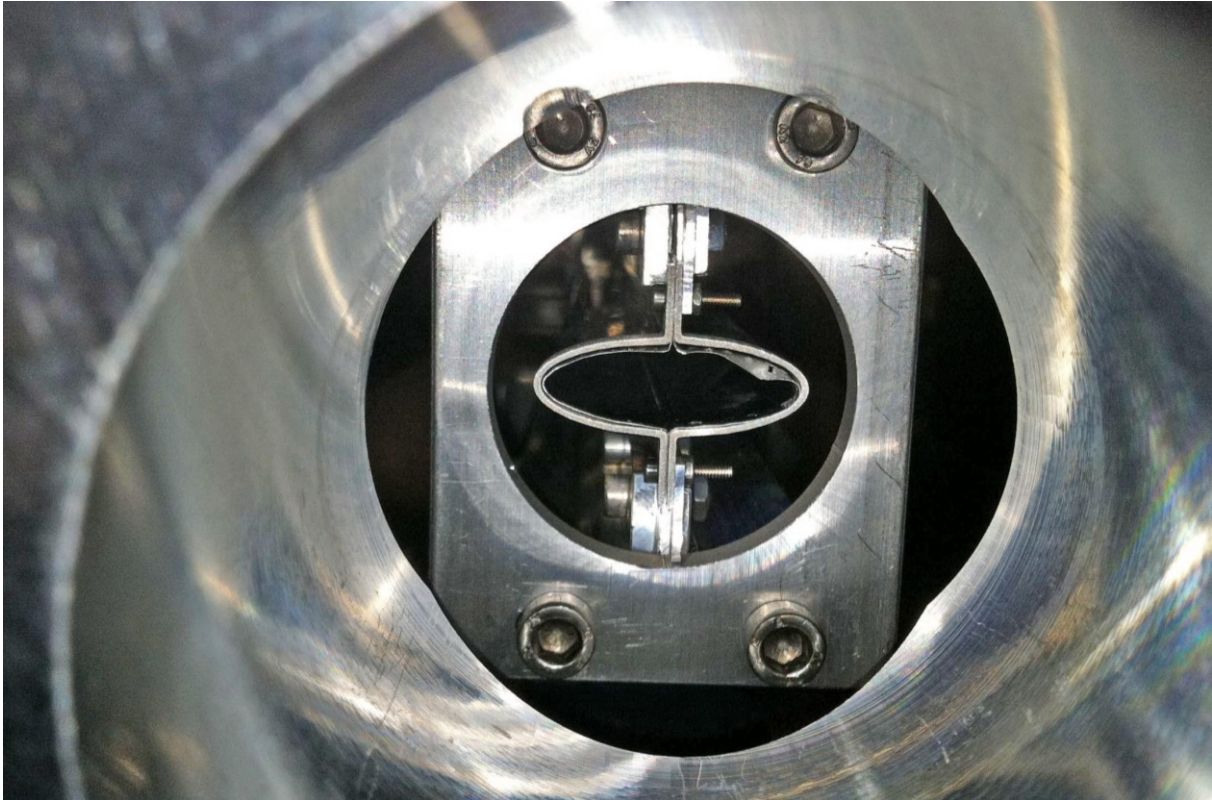

Figure 18: View to upstream end of the cell. One can recognise that the cell is damaged and the welding spots are broken.

### **Transition 5 from target cell to cone on downstream side**

At this transition one could already see from the downstream end of the chamber that the cell had an offset relative to the wake field cone. Also at this end high temperatures caused the insulation to melt. From the outside one sees clearly the offset between cell and cone and that the RF-fingers lost contact to the support ring. Figure 19 shows that also on this end the cell foil separated from the support ring.



Figure 19: View to the downstream side wakefield suppressor and and of cell.

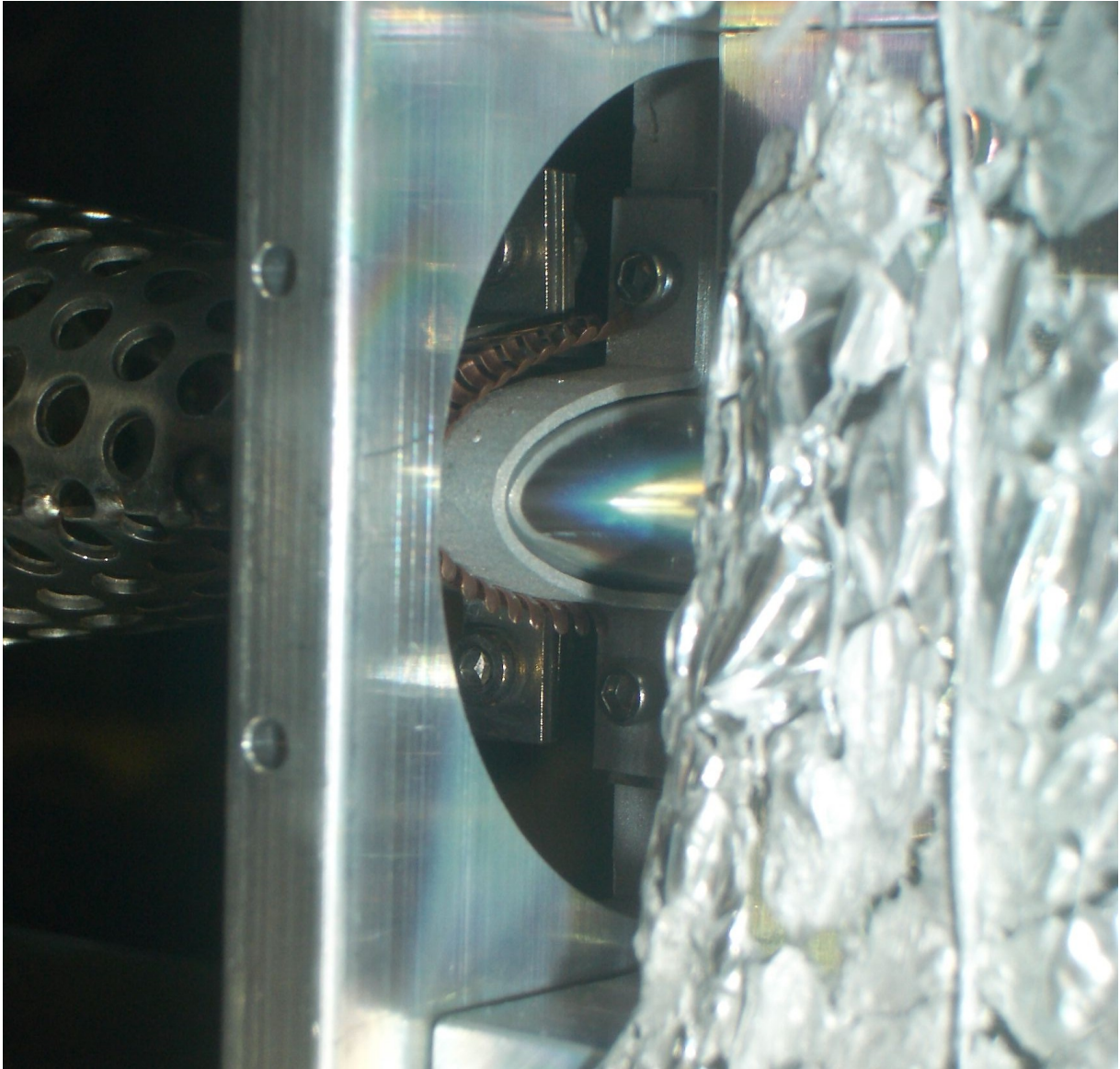

Figure 20: Downstream end. Fingers on top side without contact

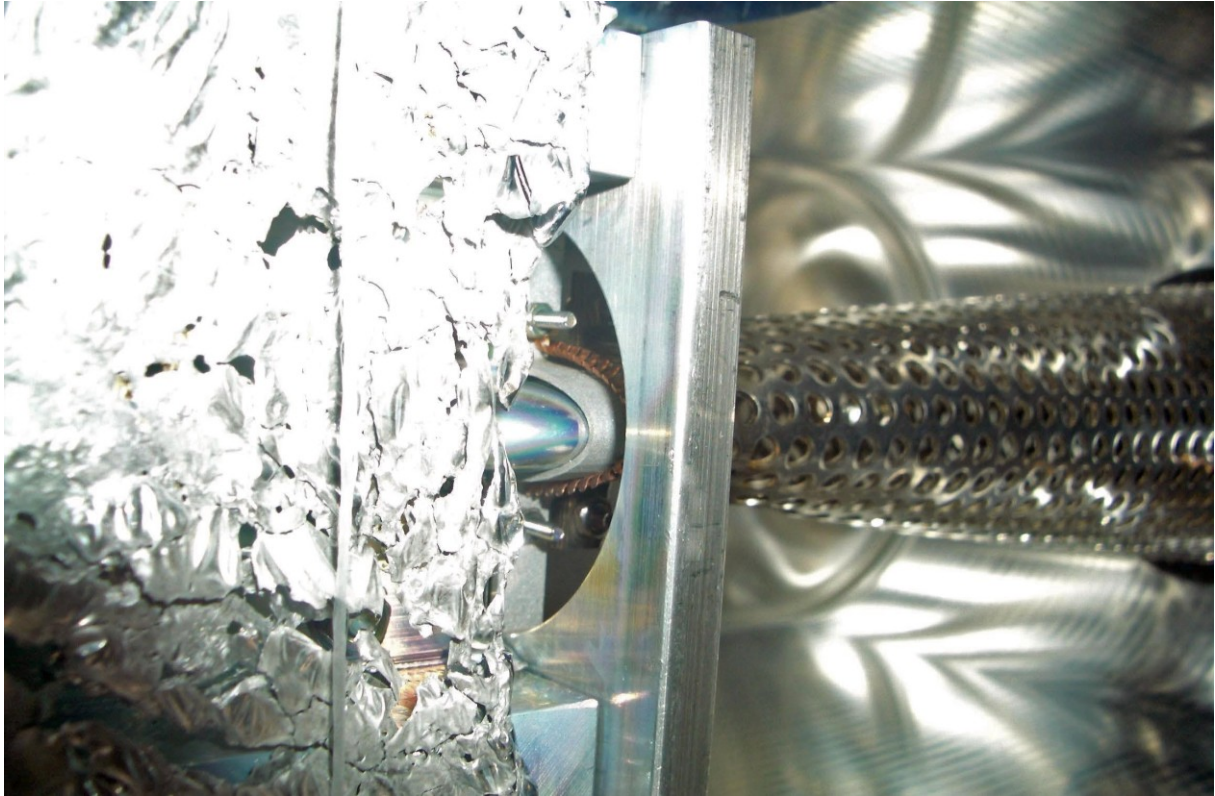

Figure 21: Downstream end of cell. Insulation is partly melted. A gap between the cell and the support ring can be seen as well as a gap between the fingers and the support ring on the upper side.

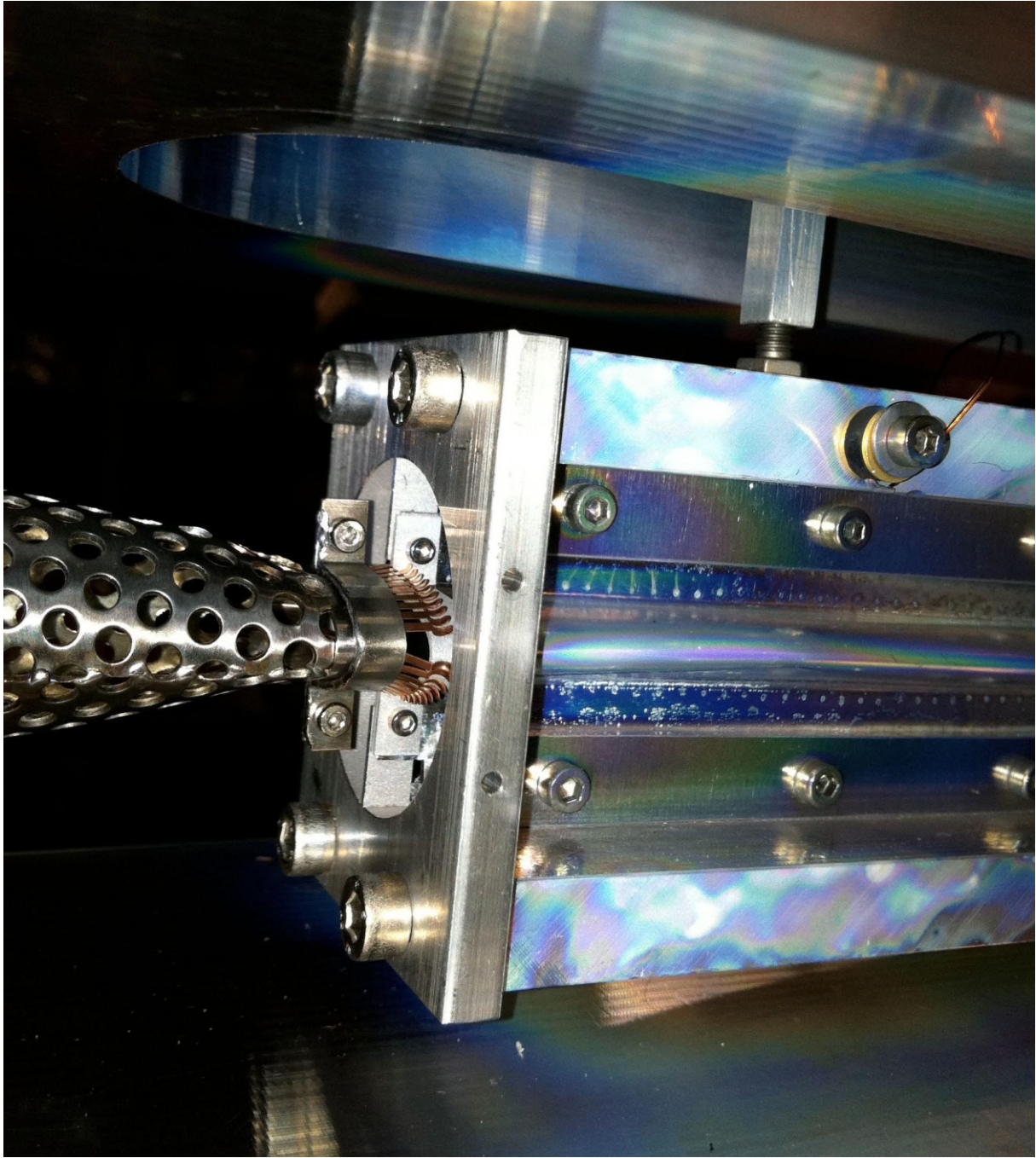

Figure 22: Downstream end of cell. the RF-fingers are bend on the lower side and have no contact on the upper side. On the top the temperature sensor can be seen.