

APPENDIX (LECTURE #2):

- I. Review / Summary of Cantilever Beam Theory
- II. Summary of Harmonic Motion
- III. Limits of Force Detection
- IV. Excerpts from *Vibrations and Waves*, A.P. French, W. W. Norton and Company, 1971 (For more information see the full reference posted on Stellar)

I. Review / Summary of Cantilever Beam Theory from 3.032 [1]

A *cantilevered* beam is one that is fixed at one end and free at the opposite end, as shown in Figure 1.

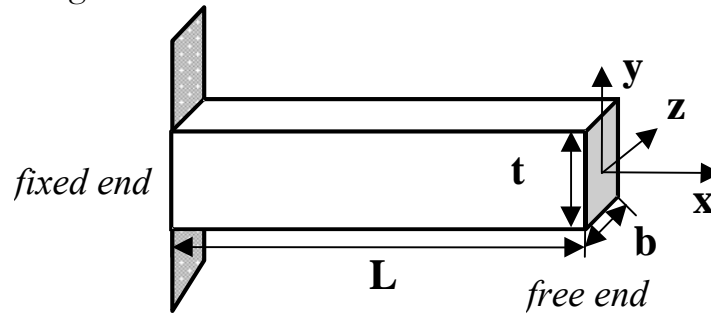

Figure 1. Nomenclature for a cantilevered beam with rectangular cross section ; L =length or span (m), b =width (m), t =height or thickness (m), I =moment of inertia of cross-sectional area (m^4), E =Young's (elastic) modulus ($Pa=N/m^2$), and EI =flexural modulus (Nm^2)

Consider the case where a concentrated force is applied in the downwards direction at the free end of a cantilever (Figure 2.).

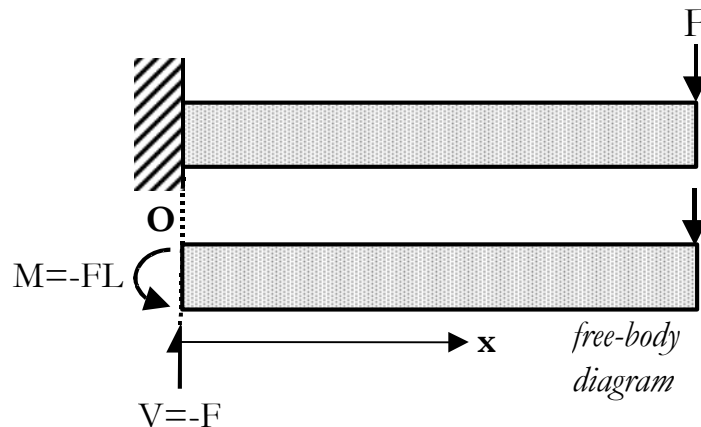

Figure 2. A loaded, cantilevered beam and corresponding free-body diagram

A free-body diagram of the beam shows that a reactant shear force, V , and a reactant bending moment M , must exist in order to maintain static equilibrium. By taking the conditions for equilibrium one finds that :

$$\sum F_y = 0 = V + F \Rightarrow V = -F \quad (1)$$

$$\sum M_o = 0 = M + FL \Rightarrow M = -FL \quad (2)$$

No matter where a transverse cut is taken along the beam and a free-body diagram constructed, the magnitude of the shear force, V , is found to be constant and equal to F throughout the length of the beam:

$$V(x) = F = \text{constant} \quad (3)$$

Since $V(x) = -\frac{dM}{dx}$, the moment, $M(x)$, varies linearly from a maximum of zero at the free end to a minimum of $-FL$ at the wall. Hence, $M(x)$ is linear and equal to :

$$M(x) = -F(L-x) \quad (4)$$

Equations (3) and (4) are shown graphically in Figure 3.

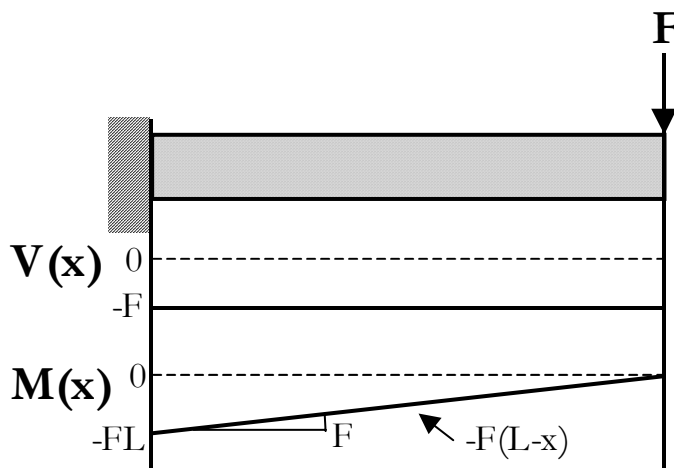

Figure 3. Shear and bending moment diagrams for the cantilevered beam given in Figure 2.

The equation for the slope of the y -displacement curve, $\theta(x)$, is defined as follows:

$$\theta(x) = \frac{1}{EI} \int_0^x M(x) dx \quad (5)$$

Substituting equation (4) into equation (5) we obtain :

$$\theta(x) = -\frac{1}{EI} \int_0^x F(L-x)dx = -\frac{1}{EI} \int_0^x (FL - Fx)dx$$

$$\theta(x) = -\frac{1}{EI} \left[(FLx) - \frac{Fx^2}{2} \right] + C_1 \quad (6)$$

The integration constant, C_1 , can be obtained from the boundary condition that the slope of y-displacement curve, $\theta(x)$, must be zero at the wall ($x=0$):

$$\theta(0) = 0 = -\frac{1}{EI} \left[(FL0) - \left(\frac{F0^2}{2} \right) \right] + C_1 \Rightarrow C_1 = 0$$

$$\theta(x) = -\frac{1}{EI} \left[(FLx) - \left(\frac{Fx^2}{2} \right) \right] \quad (7)$$

The equation for the y-displacement curve or elastic curve, $y(x)$, can be found as follows:

$$y(x) = \int_0^x \theta(x)dx \quad (8)$$

Substituting equation (7) into equation (8) we obtain :

$$y(x) = -\int_0^x \frac{1}{EI} \left[(FLx) - \left(\frac{Fx^2}{2} \right) \right] dx$$

$$y(x) = -\frac{1}{EI} \left[\left(\frac{FLx^2}{2} \right) - \left(\frac{Fx^3}{6} \right) \right] + C_2 \quad (9)$$

The integration constant, C_2 , can be obtained from the boundary condition that the y-displacement $y(x)$ must be zero at the wall ($x=0$) :

$$y(x) = 0 = -\frac{1}{EI} \left[\left(\frac{FL0^2}{2} \right) - \left(\frac{F0^3}{6} \right) \right] + C_2 \Rightarrow C_2 = 0$$

$$y(x) = -\frac{F}{EI} \left[\left(\frac{Lx^2}{2} \right) - \left(\frac{x^3}{6} \right) \right] \quad (10)$$

The maximum deflection occurs at the free end of the cantilever and can be found by substituting $x=L$ into equation (10) :

$$y_{\max}(x=L) = -\frac{FL^3}{3EI} \quad (11)$$

Equations (10) and (11) are shown graphically in Figure 4.

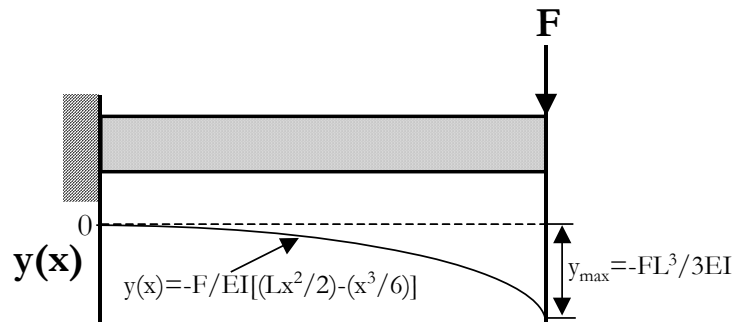

Figure 4. Elastic curve of cantilevered beam

By rearranging equation (11), one can obtain the applied load as a function of the deflection at the end of the beam:

$$F = \left(-\frac{3EI}{L^3} \right) y_{\max} \quad (12)$$

Here, we see that the applied force is directly proportional to the displacement at the end of the beam and hence, the cantilever can be represented by a linear elastic, Hookean spring (Figure 5.):

$$F = k\delta \quad (13)$$

where $\delta=y_{max}$ is the maximum deflection at the end of the cantilever (force spectroscopy notation), and k is the “cantilever spring constant” :

$$k = -\frac{3EI}{L^3} \quad (14)$$

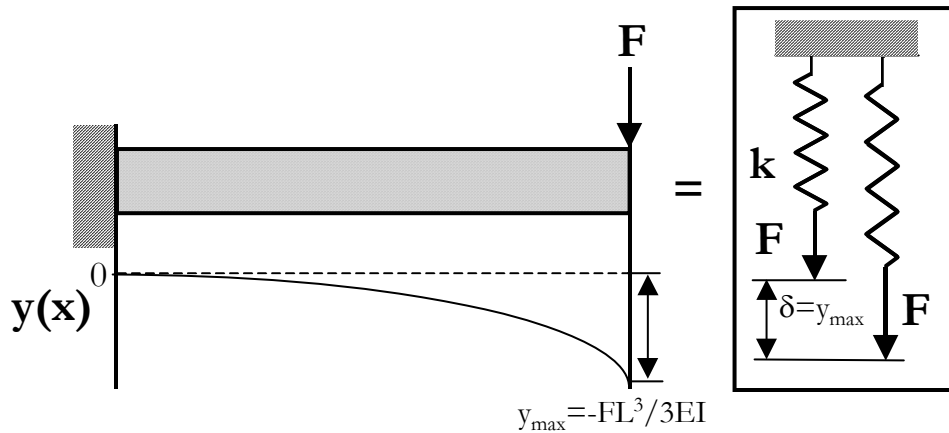

Figure 5. Representation of cantilevered beam by a linear elastic, Hookean spring

Hence, k is a function only of the beam dimensions and the elastic modulus.

Typically, V-shaped cantilevers are used for high-resolution force spectroscopy experiments (Figure 6.).

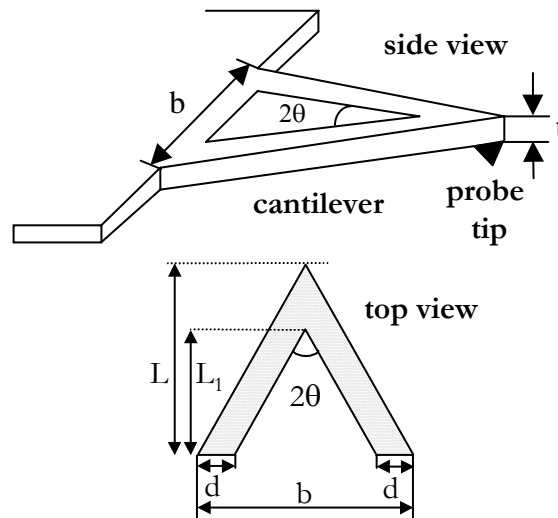

Figure 6. Dimensions of a V-shaped cantilever beam

Table I. displays approximate formulas for the k of V-shaped cantilevers.

Table I. Formulas for the k of V-shaped cantilevers [2].

Reference	Cantilever Spring Constant, k	% error
[2]	$\frac{Et^3d}{2L^3} \left[1 + \frac{b^2}{4L^2} \right]^{-2}$	25
[3]	$\frac{0.5Et^3d}{L^3}$	16
[4]	$\frac{Et^3d}{2L^3} \left[1 + \frac{4d^3}{b^3} \right]^{-1}$	13
[4]	$\frac{Et^3d}{2L^3} \cos\theta \left[1 + \left(\frac{4d^3}{b^3} \right) (3\cos\theta - 2) \right]^{-1}$	2

References :

[1] *Mechanics of Materials*, D. Roylance, John Wiley and Sons, Inc. 1996.
 [2] T. R. Albrecht, S. Akamine, T. E. Carver, and C. F. Quate, *J. Vac. Sci. Tech.* **A8**, 3386 (1990).
 [3] H.-J. Butt, P. Siedle, K. Siefert, K. Fendler, T. Seeger, E. Bamberg, A. L. Weisenhorn, K. Goldie, and A. Engel, *J. Microscopy* **169**, 75 (1993).
 [4] J. E. Sader, *Rev. Sci. Instrum.* **66** (9), 4583 (1995).

II. Summary of Harmonic Oscillators

(*reference : *Vibrations and Waves*, A. P. French, W. W. Norton and Company, NY 1971.)

II.A. Free Vibrations

Basic Physics Equations :

$\delta(t)$ =displacement(m)

$v(t)$ =velocity(m/s)= $d\delta(t)/dt=\delta'(t)$

$a(t)$ =acceleration(m/s²)= $d^2\delta(t)/dt^2=\delta''(t)$

$F(t)$ =force(N)= $ma(t)$ where : m =mass(g)

$U(\delta)$ =potential energy(Nm)= $\int F(\delta)d\delta$

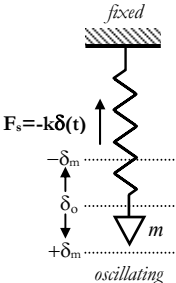
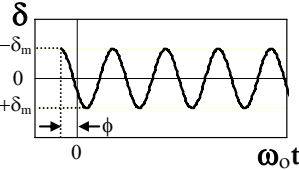
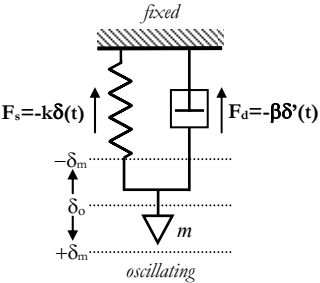
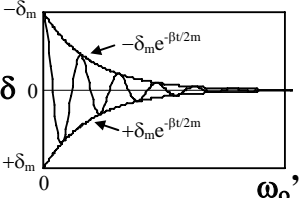
Type of Harmonic Motion :	Model Schematic :	Equations of Motion :	Solutions to Equations of Motion :
<p>Simple Harmonic Motion (SHM) : ν=natural or resonant frequency (Hz=1 oscillation/s=s⁻¹) ω=natural or resonant angular frequency=$2\pi\nu$ (rad/s⁻¹) δ_m =displacement amplitude (m) ϕ=phase constant $\omega t+\phi$=phase F_s=spring recovery force k=spring constant (N/m)</p>		$ma=F_s \Rightarrow$ $m\delta''(t)+k\delta(t)=0$	$\delta(t)=\delta_m \cos(\omega_0 t-\phi)$ $\omega_0^2=k/m$ 
<p>Damped Harmonic Motion (DHM) : β=damping (viscosity) coefficient F_d=dashpot or dissipative force ω_0'=natural or resonant angular frequency for a damped system (rad/s⁻¹) Q=quality factor</p>		$ma=F_s+F_d \Rightarrow$ $m\delta''(t)+\beta\delta'(t)+k\delta(t)=0$	$\delta(t)=\delta_m e^{-\beta t/2m} \cos(\omega_0' t-\phi)$ $\omega_0'=\sqrt{[(k/m)-(\beta^2/4m^2)]}$  $Q^2=km/\beta^2$

II.B. Forced Vibrations

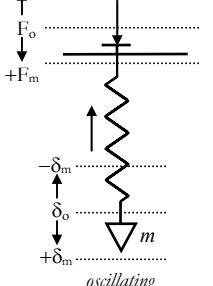
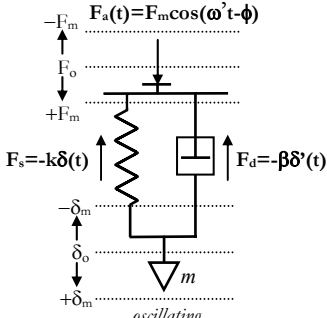
Type of Harmonic Motion :	Model Schematic :	Equations of Motion :	Solutions to Equations of Motion :
<p>Driven Harmonic Motion (DHM) : ϖ = frequency of applied force oscillation (rad/s⁻¹) $\varpi = \omega_0$ "resonance" occurs; maximum amplitude of oscillations, δ_m</p>	<p><i>forced oscillation :</i> $F_a(t) = F_m \cos(\omega t - \phi)$</p>  <p><i>oscillating</i></p>	$ma = F_s - F_a \Rightarrow$ $m\delta''(t) + k\delta(t) = F_a(t)$	$\delta(t) = \delta_m \cos(\varpi t - \phi)$ $\delta_m(\omega) = F_m / (k - m\omega^2)$
<p>Driven / Damped Harmonic Motion (DDHM) : ϖ = frequency of applied force oscillation for damped system (rad/s⁻¹)</p>	<p><i>forced oscillation :</i> $F_a(t) = F_m \cos(\omega' t - \phi)$</p>  <p><i>oscillating</i></p>	$ma = F_s + F_d - F_a \Rightarrow$ $m\delta''(t) + \beta\delta'(t) + k\delta(t) = F_a(t)$	$\delta(t) = \delta_m \cos(\varpi' t - \phi)$ $\delta_m(\omega') = F_m / (k - m\omega'^2)$ $\delta_{m(\max)} = QF_o/k(1 - 1/4Q^2)^{1/2}$

III. Limits of Force Detection [1-4]

The lower bound of force detection of any force spectroscopy measurement is determined either by the *resolution* or *thermal fluctuations* of the transducer.^{1,2}

Transducer Resolution. Previously, we have shown that a high-resolution force transducer can be represented by a linear elastic, Hookean spring (equation (13)). Let's assume that the minimum detectable displacement is a one-atom deflection ($\delta_{\min}=0.1$ nm). Substituting this value into equation (13) we obtain the minimum detectable force, F_{\min} :

$$F_{\min} = (0.1 \text{ nm})k \quad (15)$$

Thermal Oscillations. In the absence of any externally applied forces, a force transducer in equilibrium with its surroundings will fluctuate due to the nonzero thermal energy at room temperature, $k_B T = 4.1 \cdot 10^{-21}$ Nm, where k_B is the Boltzmann constant $= 1.38 \cdot 10^{-23}$ J/K and T is the absolute temperature (room temperature ≈ 295 K). If we model the force transducer as a one-dimensional, free harmonic oscillator as shown in Figure 7.

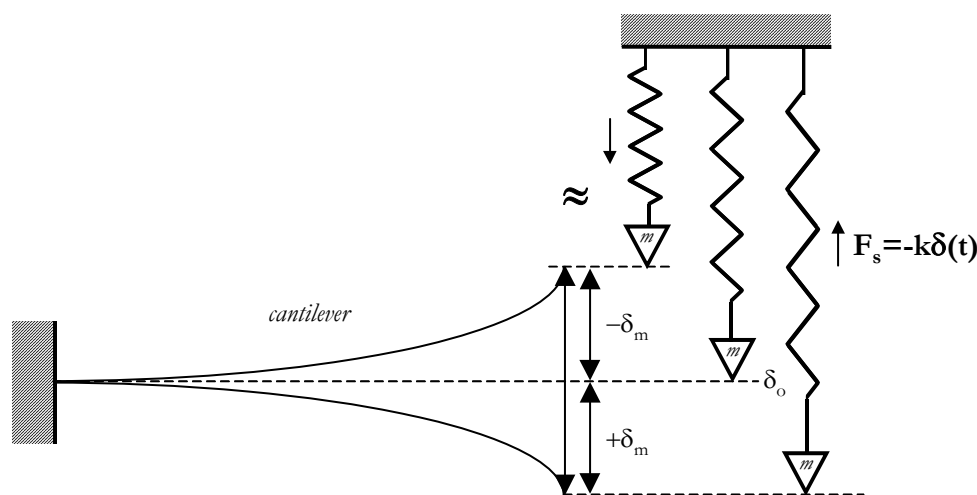

Figure 7. Thermal oscillation of a free cantilever beam

By neglecting higher modes of oscillation and making use of the equipartition theorem, the average root-mean-square (RMS) amplitude of the displacement oscillation, $\langle \delta_m^2 \rangle^{1/2}$, can be derived as follows.

The potential energy of a force transducer is

$$U = \int_0^{\delta} F(\delta) d\delta \quad (16)$$

Substituting Hooke's law for a free, one-dimensional harmonic oscillator (equation (13)) into equation (17) and integrating gives

$$U = \int_0^{\delta} k\delta d\delta \Rightarrow U = \frac{1}{2}k\delta^2 \quad (17)$$

The equipartition theorem states that if a system is in thermal equilibrium, every independent quadratic term in the total energy has a mean value equal to $\frac{1}{2}k_B T$. Hence,

$$U = \frac{1}{2}k \delta_m^2 = \frac{1}{2}k_B T \quad (18)$$

where δ_m is the amplitude of the displacement oscillation (Figure 7).

Rearranging equation (1) and solving for δ_m we obtain

$$\langle \delta_m^2 \rangle^{1/2} = \sqrt{\frac{k_B T}{k}} \quad (19)$$

where : $\langle \rangle$ denotes a statistical mechanical average over time. Substituting eq. (19) into Hooke's Law, equation (13), gives the equation for the RMS amplitude fluctuations in force:

$$\langle F_m^2 \rangle^{1/2} = \sqrt{\frac{k_B T}{k}} \quad (20)$$

A more precise formulation can be derived for a damped harmonic oscillator^[5]:

$$\langle F_m^2 \rangle^{1/2} = \sqrt{\frac{4k_B T k B}{\omega_o' Q}} \quad (21)$$

where B is the measured bandwidth (s^{-1}), Q is the quality factor $= (km)^{1/2} / \beta$, m is the mass (Ns^2/m), β is the damping coefficient (Ns/m), ω_o' is the resonant frequency for a damped system (s^{-1}), and k is the transducer spring constant (N/m).

References :

- [1] E. Evans, K. Ritchie, and R. Merkel, *Biophys. J.* **1995**, *68*, 2580.
- [2] *Nanosystems : Molecular Machinery, Manufacturing, and Computation*, K. Eric Drexler, John Wiley and Sons, 1992.
- [3] J. L. Hutter, Bechhoefer, *J. Rev. Sci. Instrum.* **1993**, *64*, 1868.
- [4] H.-J. Butt, P. Siedle, K. Seifert, K. Fendler, T. Seeger, E. Bamberg, A. L. Weisenhorn, K. Goldie, and A. Engel *J. Microsc.* **1993**, *169*, 75-84.
- [5] D. Sarid, *Scanning Force Microscopy*, Oxford University Press, p. 48