

I. The Bipolar Junction Transistor

A. Physical Structure:

- oxide-isolated, low-voltage, high-frequency design
- typical of the bipolar transistor found in a BiCMOS process,

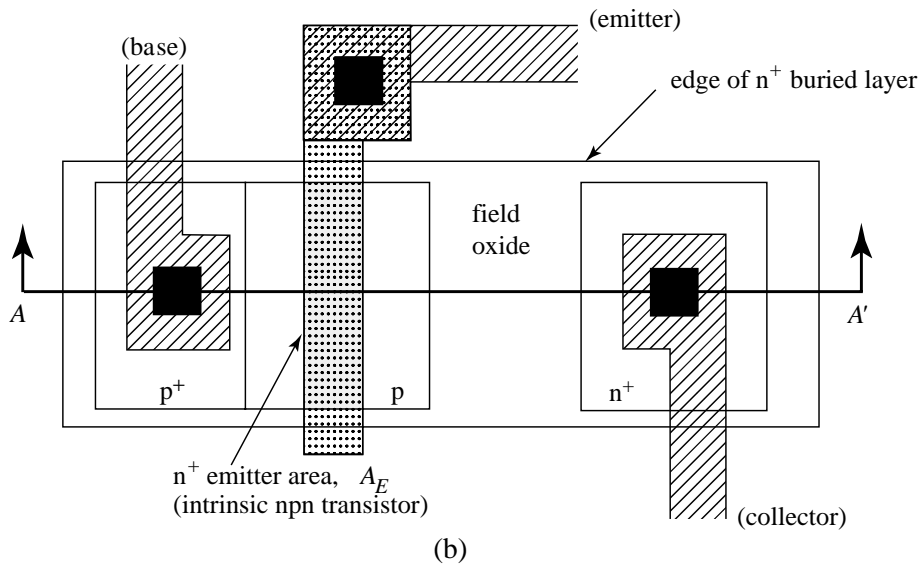
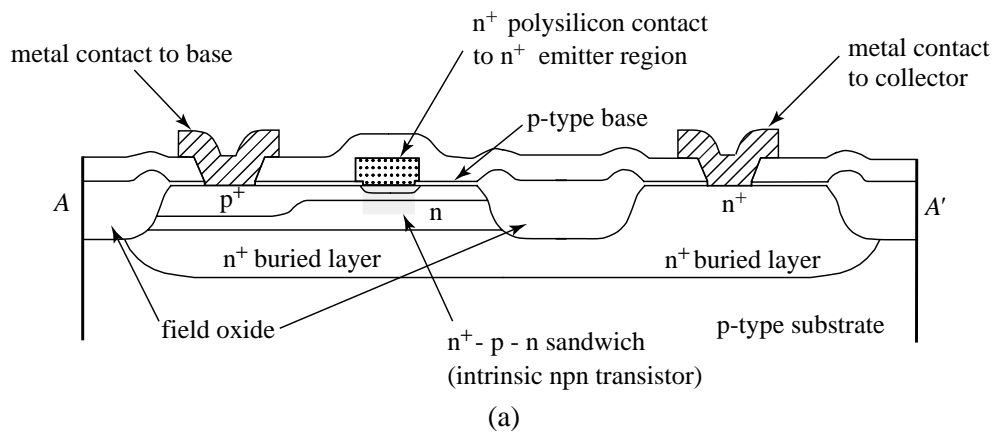

B. Circuit Symbol and Terminal Characteristics

- Two devices that have complementary characteristics npn transistor and the pnp transistor
- The direction of the diode arrow indicates device type

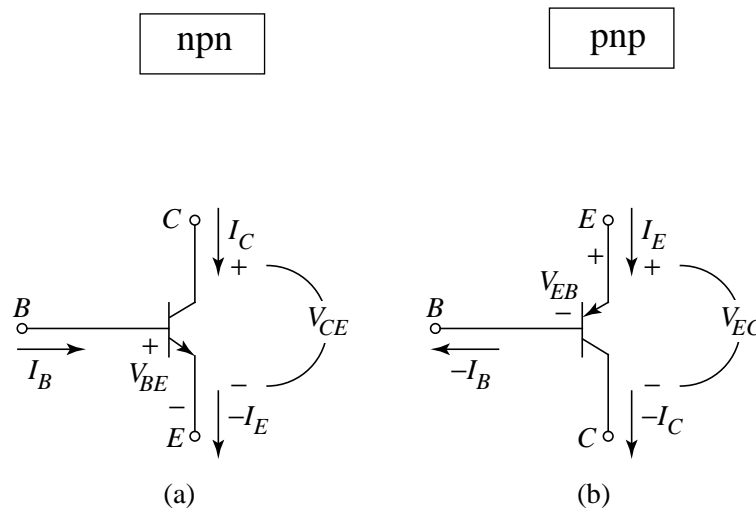

Normal operation:

I_C positive	V_{CE} positive
I_B positive	$V_{BE} = 0.7$
$-I_E$ positive	

Normal operation:

$-I_C$ positive	V_{EC} positive
$-I_B$ positive	$V_{EB} = 0.7$
I_E positive	

C. npn BJT Collector Characteristics

- Similar test circuit as for n-channel MOSFET ... except I_B is controlled instead of V_{BE}

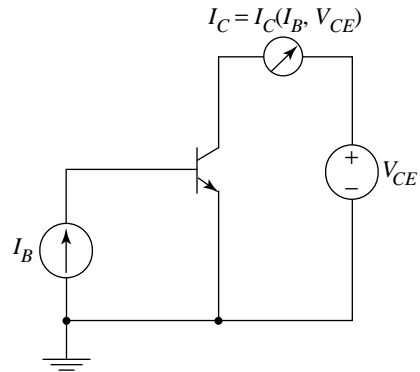

(a)

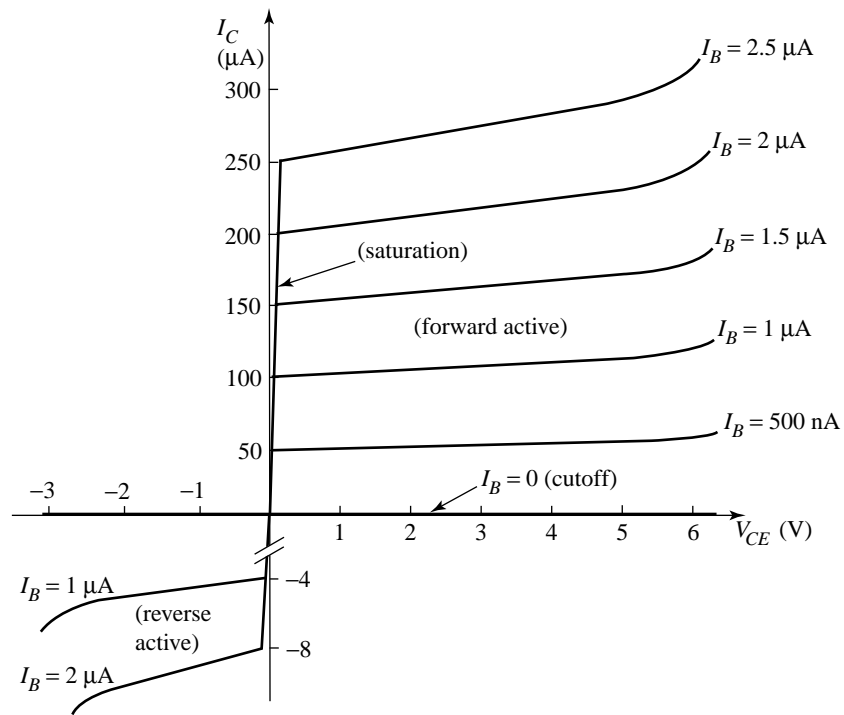

(b)

D. Regions of Operation

- Constant-current region is called *forward active* ... corresponds to **MOSFET saturation region (!!!)**

$$I_C = \beta_F I_B$$

- Bipolar *saturation* region (modeled as a constant voltage) corresponds to **MOSFET triode region**

$$V_{CE} \approx V_{CE(sat)} = 0.1V$$

- *Cutoff* ... corresponds to MOSFET cutoff region
- *Reverse active* ... terminal voltages for npn sandwich are flipped so that V_{CE} is negative and $V_{BC} = 0.7V$. Only occasionally useful.

- Boundary between saturation and forward-active regions:

$$V_{CE} > V_{CE(sat)} \quad \text{and} \quad I_B > 0$$

II. Bipolar Transistor Physics

A. Forward Active Region of Operation

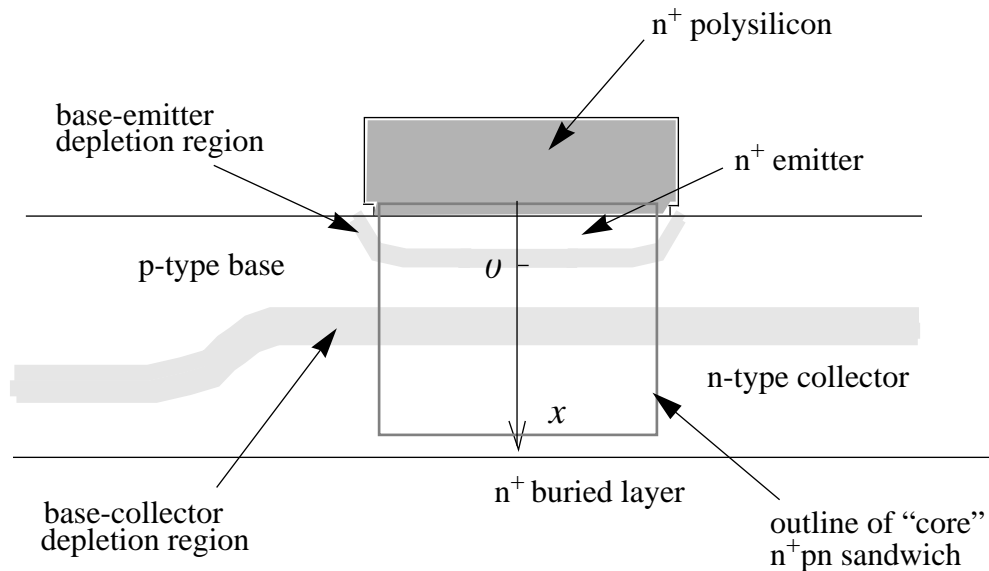

B. Game Plan

- Understand thermal equilibrium potential and carrier concentrations.
- Apply the Law of the Junction with $V_{BE} \approx 0.7$ V and $V_{BC} < 0$ (typical forward-active bias point) to find the minority carrier concentrations at the depletion region edges.
- Assume that the emitter and the base regions are "short" (**no recombination**) and find the diffusion currents.

C. Thermal Equilibrium

- Typically emitter is doped two orders of magnitude (at least) more heavily than the base; the collector is an order of magnitude more lightly doped than the base.
- Minority carrier concentrations:

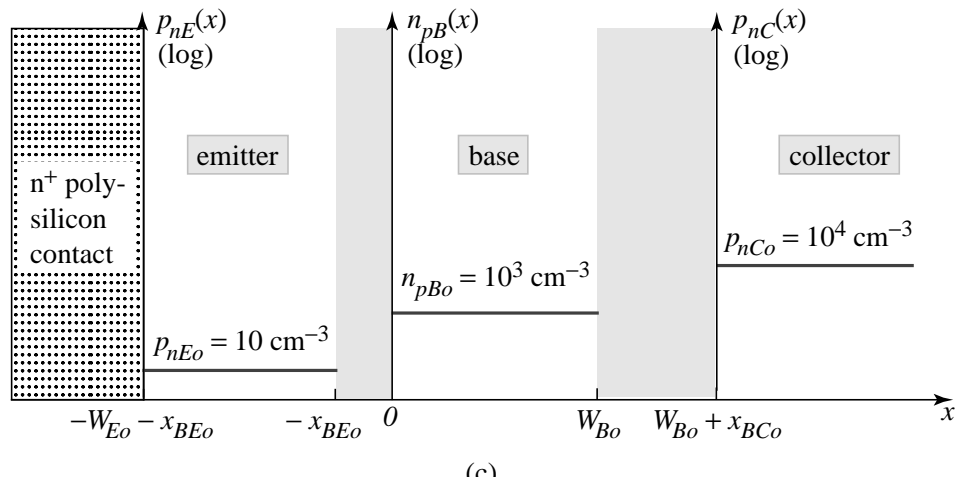

- Electrostatic potential:

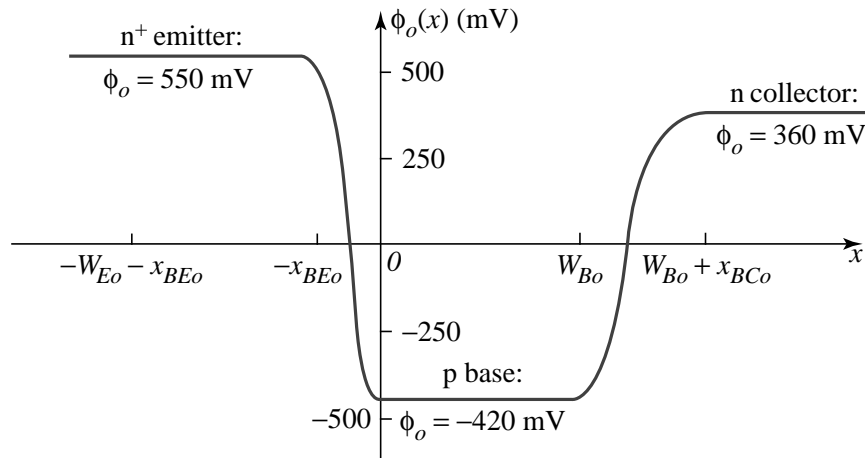

D. Carrier Concentrations under Forward Active Bias

- Boundary conditions at the edges of the depletion region are:

Emitter-Base: $\exp[V_{BE} / V_{th}] \gg 0$Base-Collector: $\exp[V_{BC} / V_{th}] = 0$

- Ohmic contacts return carrier concentration to equilibrium

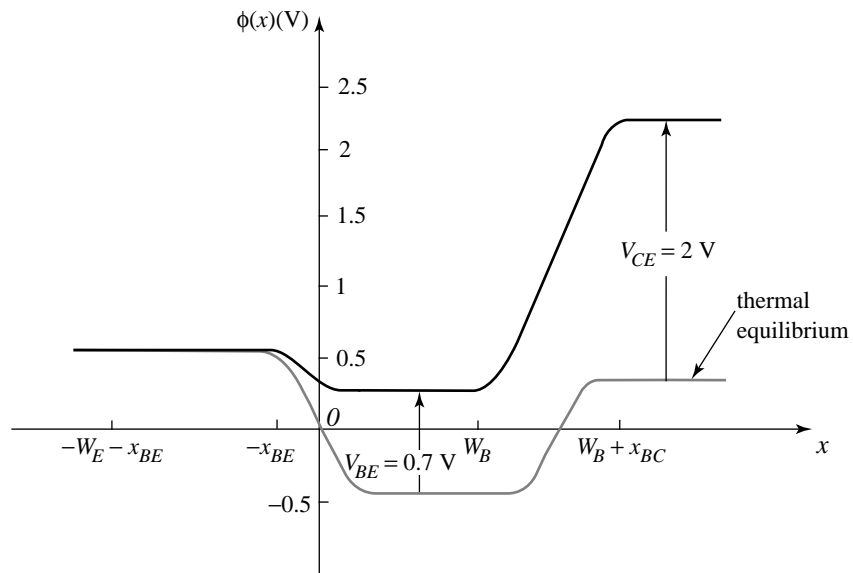

(a)

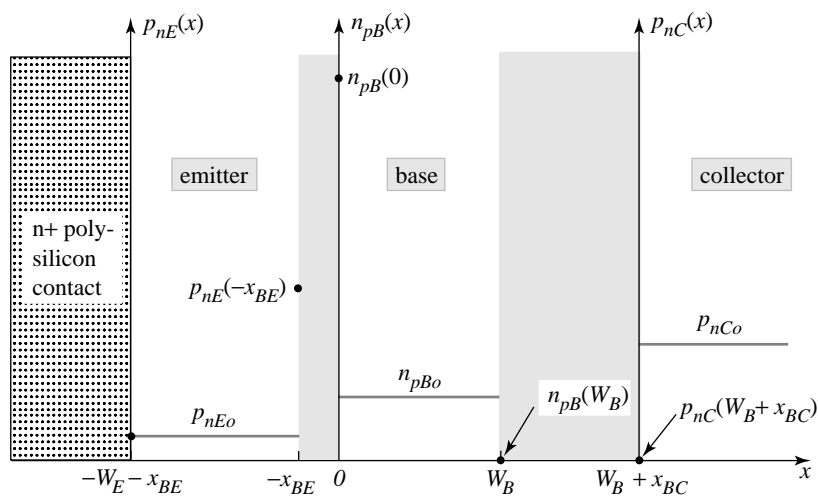

(b)

E. The Flux Picture - Forward Active Bias

- Rather than current densities, we use the concept of *flux* [# per cm² per second]
- The width of the electron flux “stream” is greater than the hole flux stream.

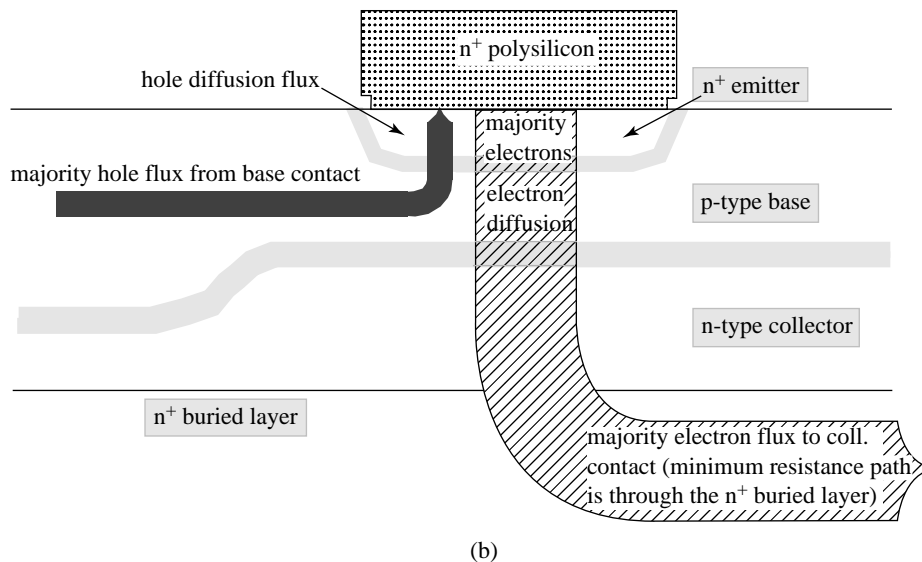

- The electrons are supplied by the emitter contact and diffuse across the base
- Electric field in the collector depletion region sweeps electrons into the collector
- n⁺ buried layer provides a low resistance path to the collector contact
- The holes are supplied by the base contact and diffuse across the emitter
- The reverse injected holes are recombined at the polysilicon ohmic contact

III. Forward-Active Terminal Currents

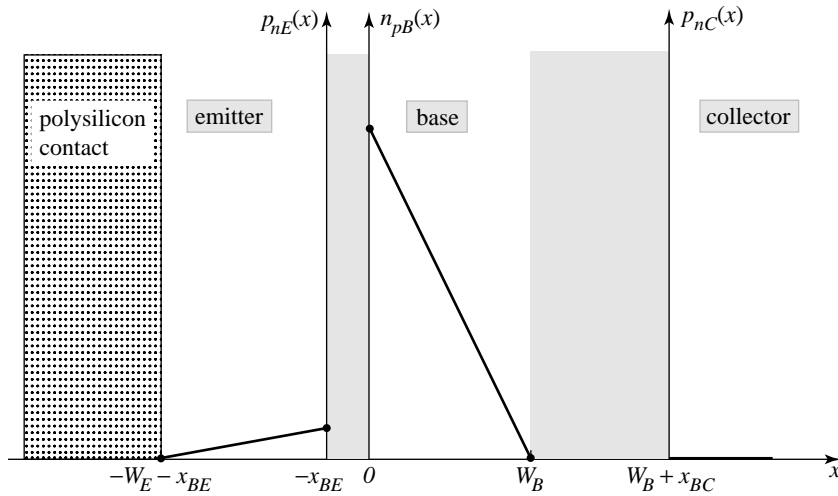

A. Collector current:

- Electron diffusion current density X emitter area

$$J_{nB}^{diff} = qD_n \left(\frac{n_{pB}(W_B) - n_{pB}(0)}{W_B} \right) = qD_n \frac{n_{pBo} \left(e^{V_{BC}/V_{th}} - e^{V_{BE}/V_{th}} \right)}{W_B}$$

$$I_C = -J_{nB}^{diff} A_E = \left(\frac{qD_n n_{pBo} A_E}{W_B} \right) e^{V_{BE}/V_{th}}$$

B. Base current

- Reverse-injected hole diffusion current density X emitter area

$$J_{pE}^{diff} = -\left(\frac{qD_p p_{nEo}}{W_E}\right) (e^{V_{BE}/V_{th}} - 1)$$

$$I_B = -J_{pE}^{diff} A_E = \left(\frac{qD_p p_{nEo} A_E}{W_E}\right) (e^{V_{BE}/V_{th}} - 1)$$

C. Emitter current

- Sum of I_B and I_C according to KCL (negative ... reference is positive-in)

$$I_E = (J_{nB}^{diff} + J_{pE}^{diff}) A_E = -\left[\left(\frac{qD_p p_{nEo} A_E}{W_E}\right) + \left(\frac{qD_n n_{pBo} A_E}{W_B}\right)\right] e^{V_{BE}/V_{th}}$$

IV. Forward-Active Current Gains

A. Alpha-F - α_F

- The ratio of collector current to the magnitude of the emitter current

$$\frac{I_C}{|I_E|} = \frac{\left(\frac{qD_n n_{pBo} A_E}{W_B} \right)}{\left(\frac{qD_p p_{nEo} A_E}{W_E} \right) + \left(\frac{qD_n n_{pBo} A_E}{W_B} \right)} = \alpha_F$$

$$\alpha_F = \frac{1}{1 + \left(\frac{D_p N_{aB} W_B}{D_n N_{dE} W_E} \right)}$$

- $\alpha_F \rightarrow 1$... typically, $\alpha_F = 0.99$.

B. Beta Forward Current Gains - β_F

- The ratio of collector current to base current

$$I_B = -I_E - I_C = \frac{I_C}{\alpha_F} - I_C = I_C \left(\frac{1 - \alpha_F}{\alpha_F} \right)$$

$$I_C = \left(\frac{\alpha_F}{1 - \alpha_F} \right) I_B = \beta_F I_B$$

- A typical value is $\beta_F = 100$