

MASSACHUSETTS INSTITUTE OF TECHNOLOGY
Department of Electrical Engineering and Computer Science

6.334 Power Electronics
 Problem Set 1

Issued: February 9, 2007
 Due: February 16, 2007

Reading: KSV Chapter 3

Problem 1.1 KSV Problem 3.2.

Problem 1.2

Figure 1.1 shows a circuit model for the utility supplying one phase of an ac induction motor. The motor system parameters are $R_s = 0.08 \Omega$, $L_{ls} = 1 \text{ mH}$, $L_m = 40 \text{ mH}$, $L_{lr} = 1 \text{ mH}$, $R_r = 0.1 \Omega$, and $R_x = 33 \Omega$.

If the utility voltage is $170 \cdot \cos(377t)$, what is the current into the motor?

At what power factor is the motor operating?

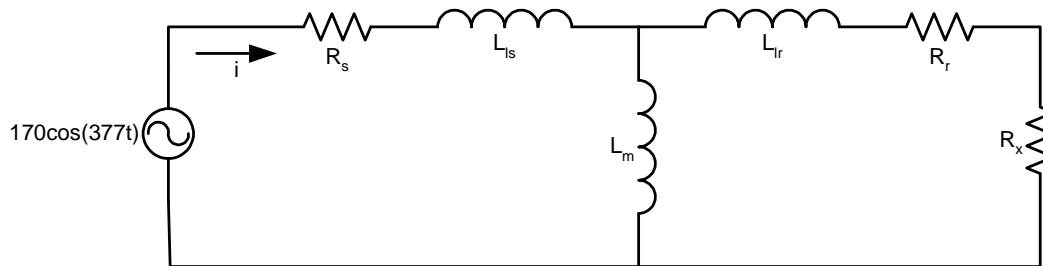

Figure 1.1 A Circuit model for one phase of an induction motor being driven by the utility.

Problem 1.3

Figure 1.2 shows a half-wave rectifier driven by a sinusoidal *current* source supplying a capacitively-filtered output. (Such a configuration is sometimes found in resonant dc-dc converters.) Determine the power factor seen by the current source, assuming that the diodes act ideally and capacitance C_f is large enough such that the output voltage has small ripple ($v_D \approx V_D$).

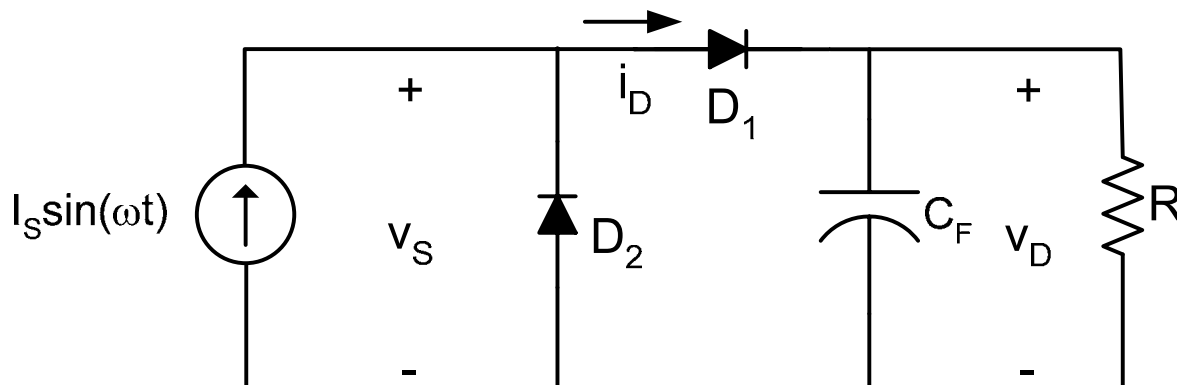

Figure 1.2 A half-wave rectifier driven from a sinusoidal current source.

Problem 1.4

Consider the half-wave rectifier circuit shown in KSV Fig. 3.9(a). What would the load regulation characteristic of this circuit be if it were driven with a *square wave* having peak voltage V_s and period $2\pi/\omega$, instead of a sine wave? Plot the resulting load regulation curve. (Note that this situation occurs in some types of isolated dc/dc power converters.)

Problem 1.5

Consider the magnetic stimulator circuit from the previous homework, repeated below as Fig. 1.3. Using any time-domain simulation tool you want (e.g. PSPICE, PSIM, etc.), simulate the circuit for 1 ms after the switch is closed. Assume that $V_c = 950$ V when switch S is closed. Note that links for acquiring some time-domain simulators are available on the 6.334 web page.

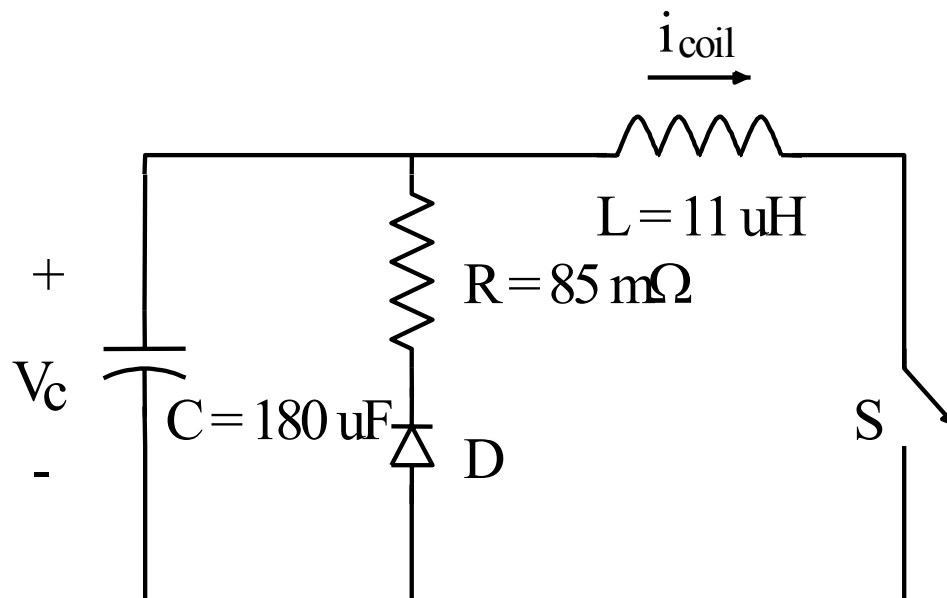

Figure 1.3 Schematic of the magnetic stimulator circuit to be simulated. The capacitor voltage V_c is precharged to 950 V when the switch S is closed.