

Electrical Conductivity and Transference Number Measurements of FeO - CaO - MgO - SiO₂ Melts

Andrew Ducret, Deepak Khetpal and
Donald R. Sadoway

Department of Materials Science & Engineering
Massachusetts Institute of Technology
Cambridge, Massachusetts
U.S.A.

background

problems with electrolytic technologies:

p unfavorable by-products ☹️

+ Al electrolysis makes CO_2 🌍
($\frac{1}{2}$ kg C / kg Al)

+ Mg electrolysis makes Cl_2 ☠️

a technological response?

most metals are found in nature as oxides

“like dissolves like”

+ **molten oxide electrolysis:**

extreme form of molten salt electrolysis
where pure **oxygen** gas is by-product



schematic of prototype cell

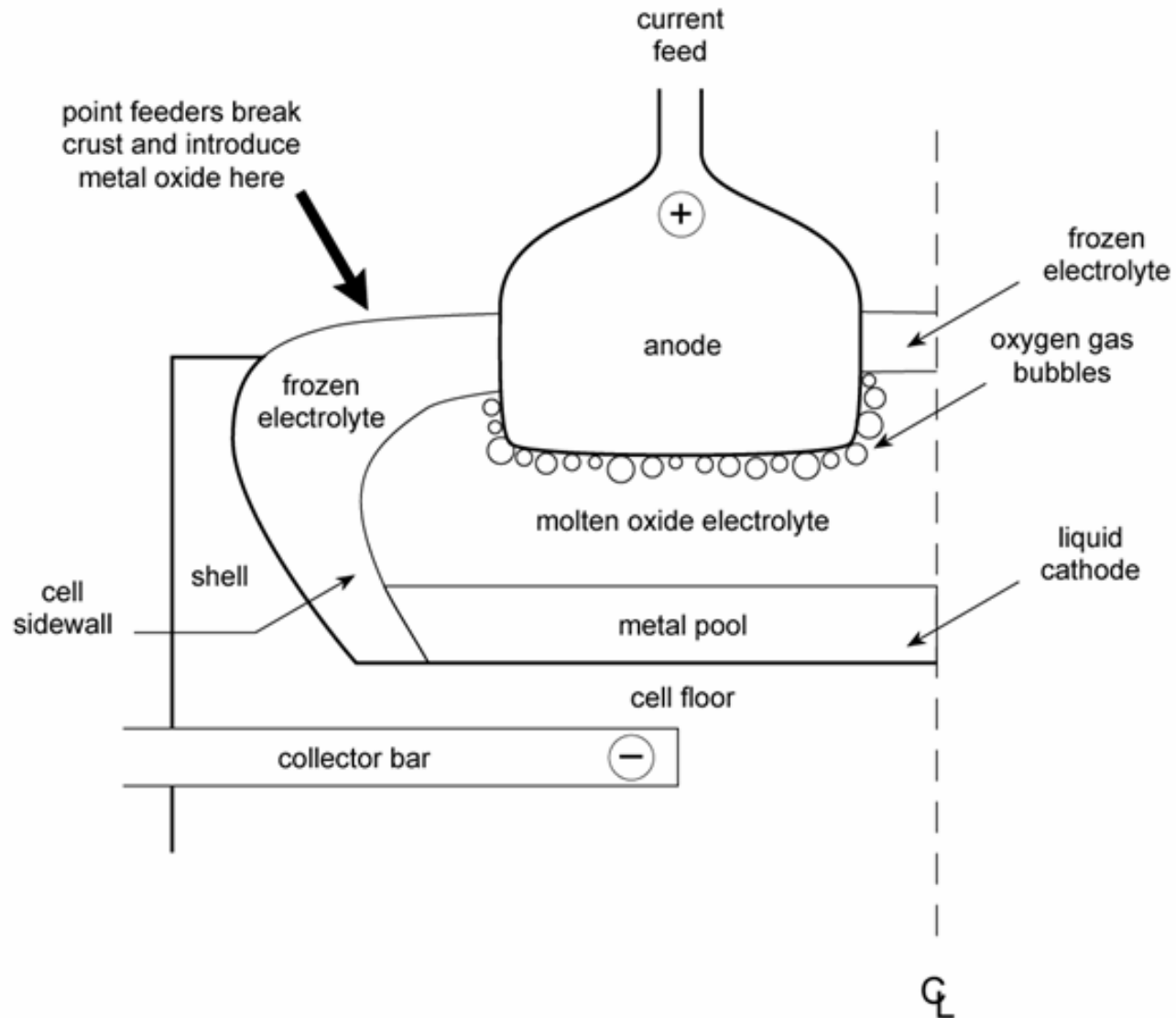

reaction of US industry?

“... new technology which will eliminate the production of CO₂ which is the unavoidable result of using carbon... Through AISI, we have therefore encouraged NSF and other agencies **to support Don Sadoway's work** as a modest investment towards the **steel technology** which may be required to match the **long term needs** of the industrial ecology.”

Thomas J. Usher, President, U.S. Steel Group

from a speech delivered at MIT, November 2, 1993

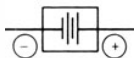

lunar colonization: NASA

? breathable oxygen



lunar regolith is a multicomponent silicate rich in **iron** and **titanium**.



ferrites and titanates are liquid semiconductors

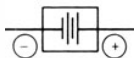

feasibility assessment

- p electrical conductivity measurements
- p transference number measurements
- p modeling electrical properties
- p applicability to oxygen generation



all-metal, coaxial-cylinder electrode

enabling high-accuracy
conductivity
measurements in the
most chemically
aggressive melts

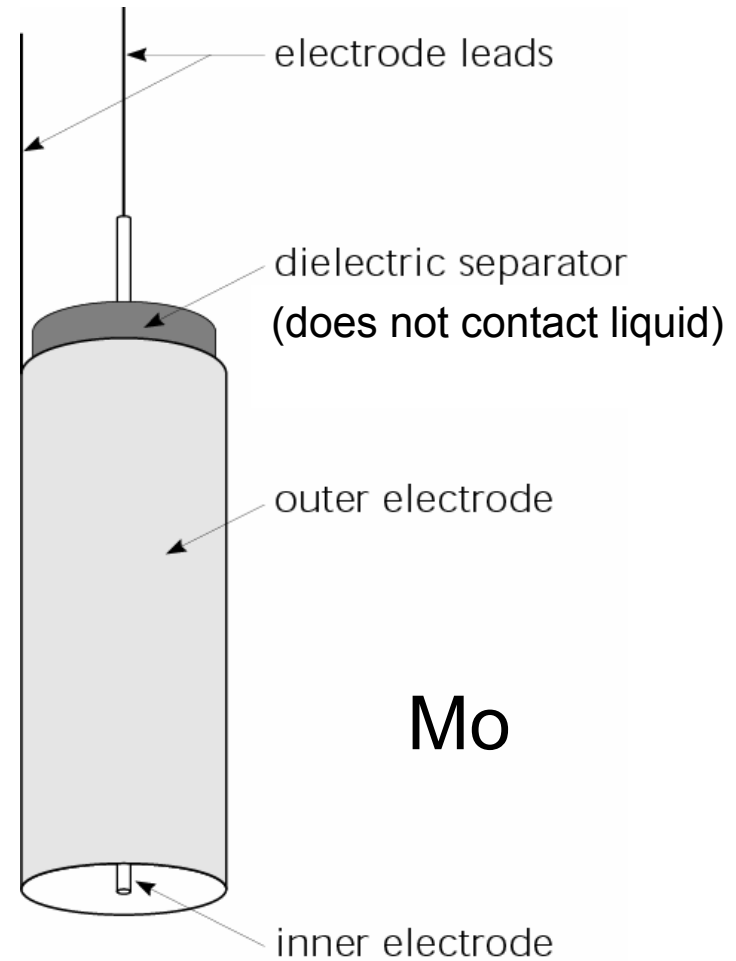

experimental apparatus

conductivity measurements:

- impedance spectroscopy
- varying immersions
- + isolate melt resistance

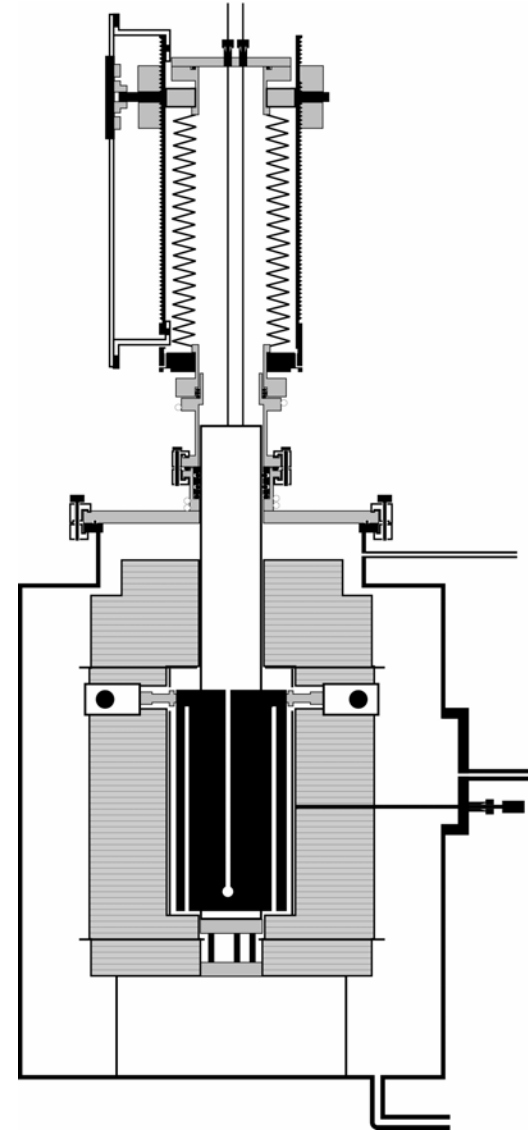

experimental apparatus

transference number
measurements:

- stepped-potential
chronoamperometry with
impedance correction
- + isolate electronic and ionic
components of conductivity

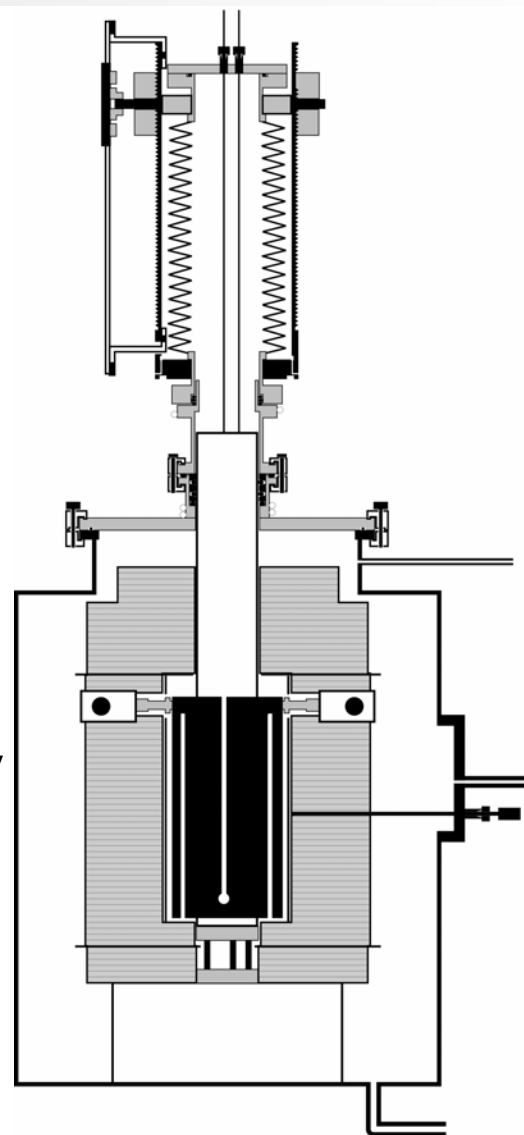

solvent compositions

FeO additions to S1

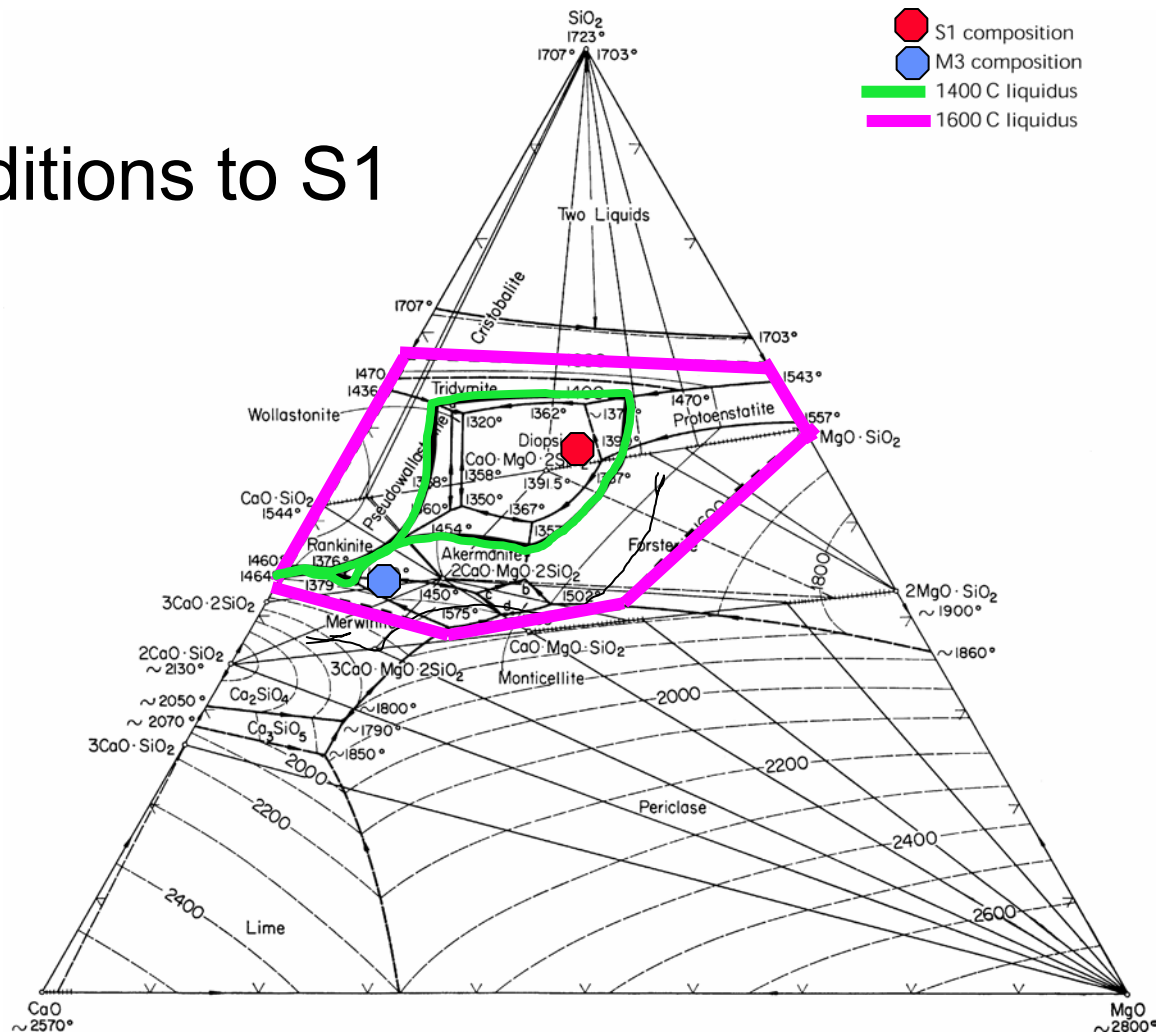

$\sigma = \sigma(T)$ at $c = S1$

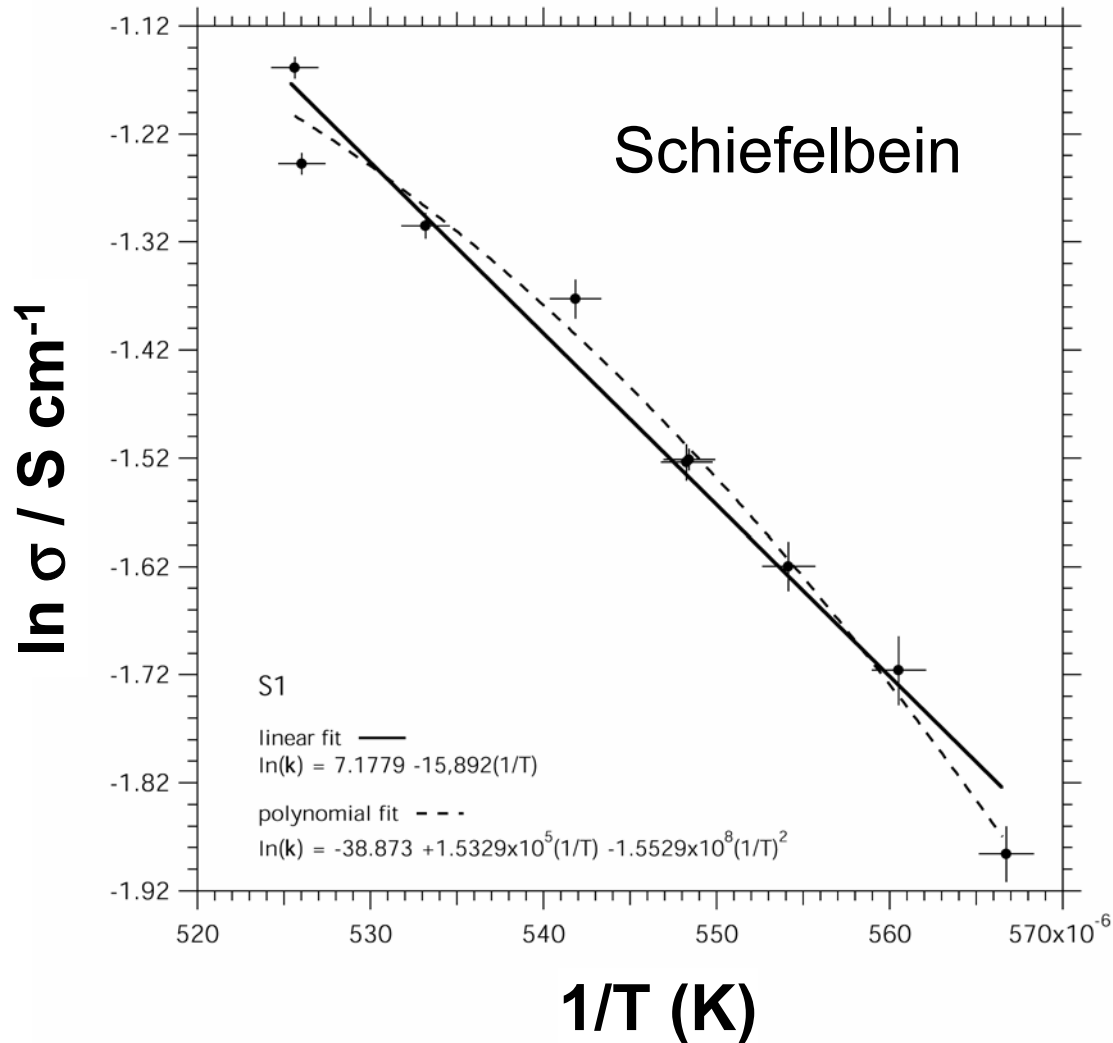

effect of FeO addition: $\sigma = \sigma(T, c)$

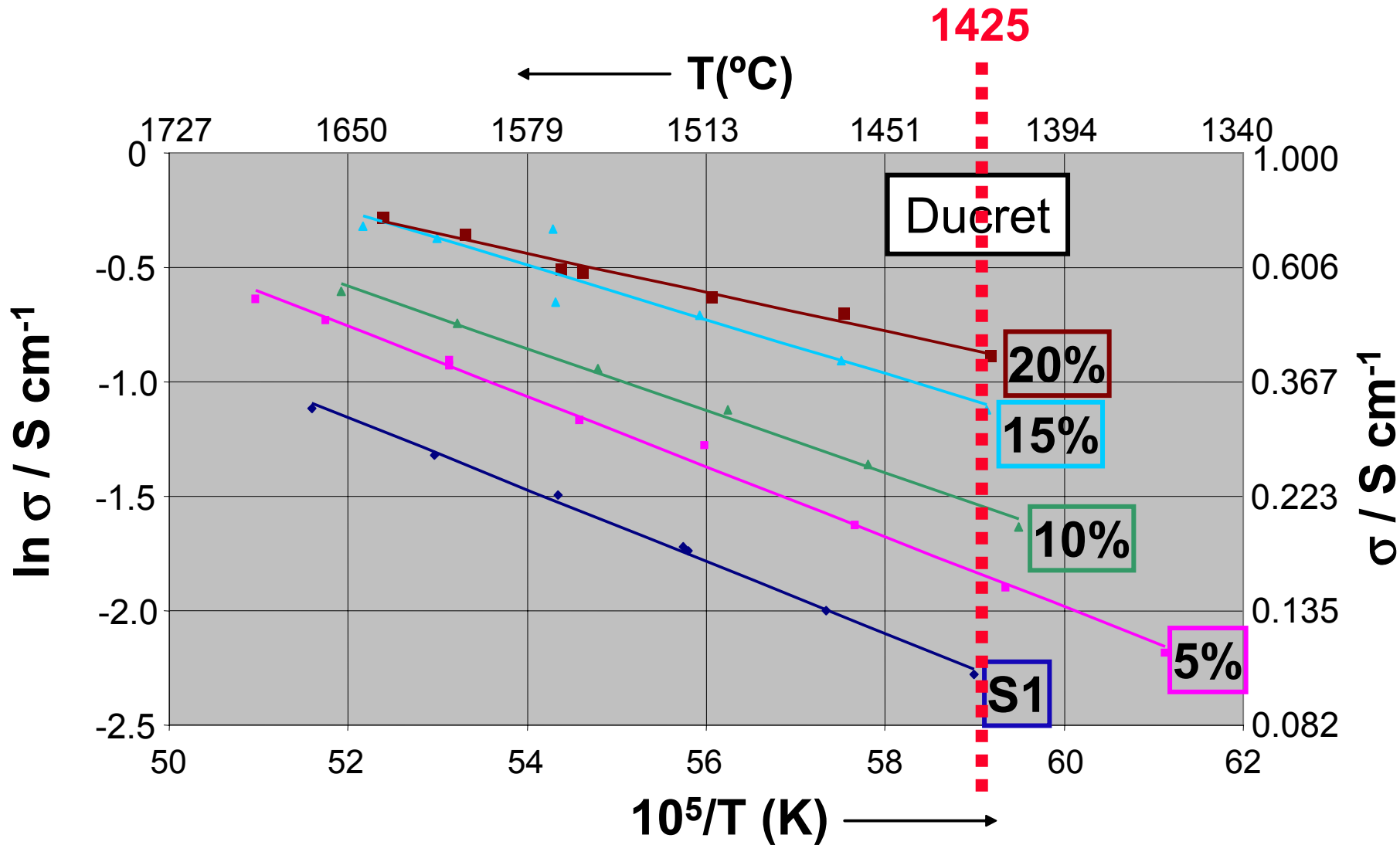

FeO greatly raises conductivity

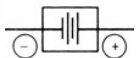
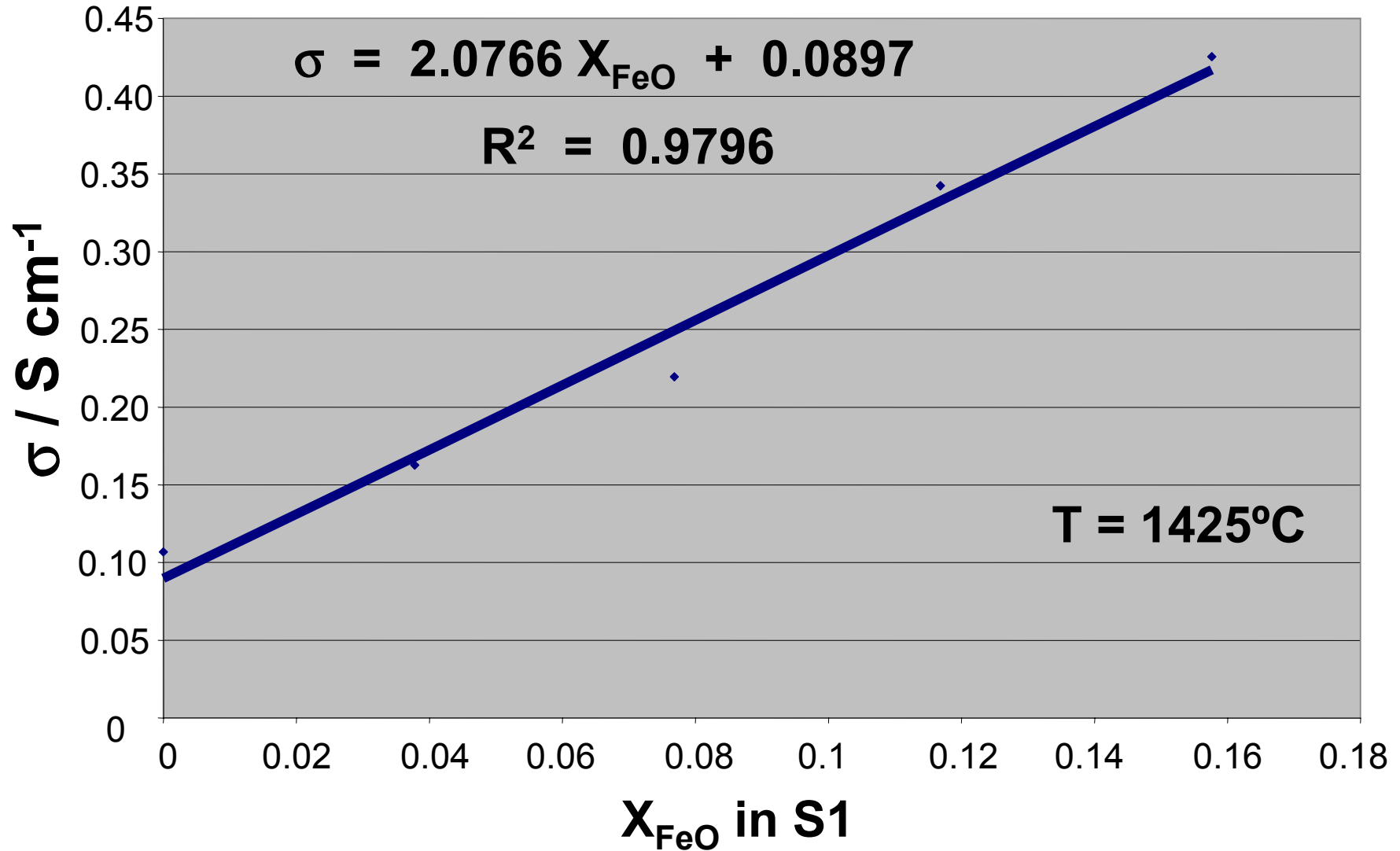

FeO acts as an electron donor

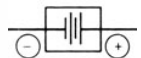
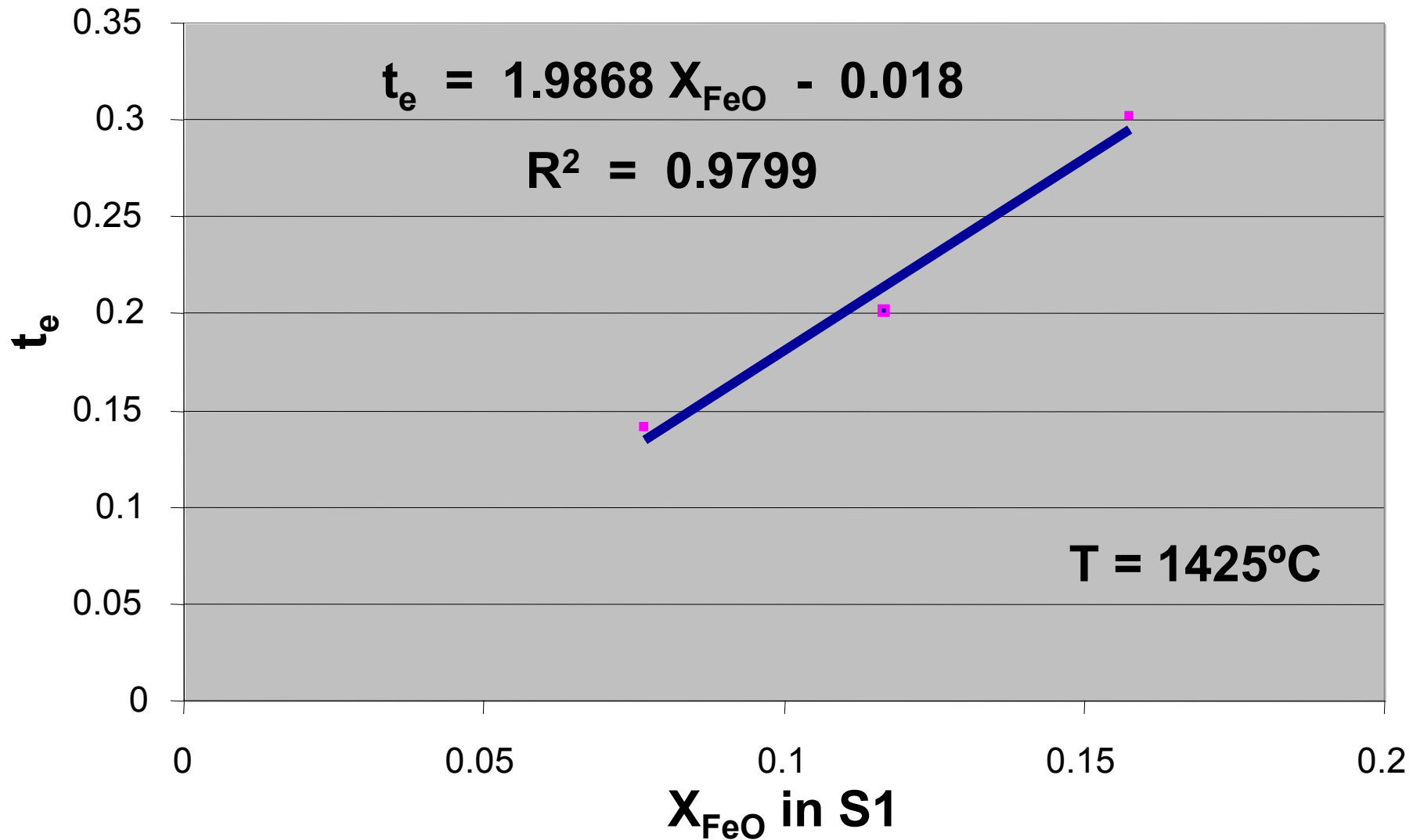

regression of conductivity data

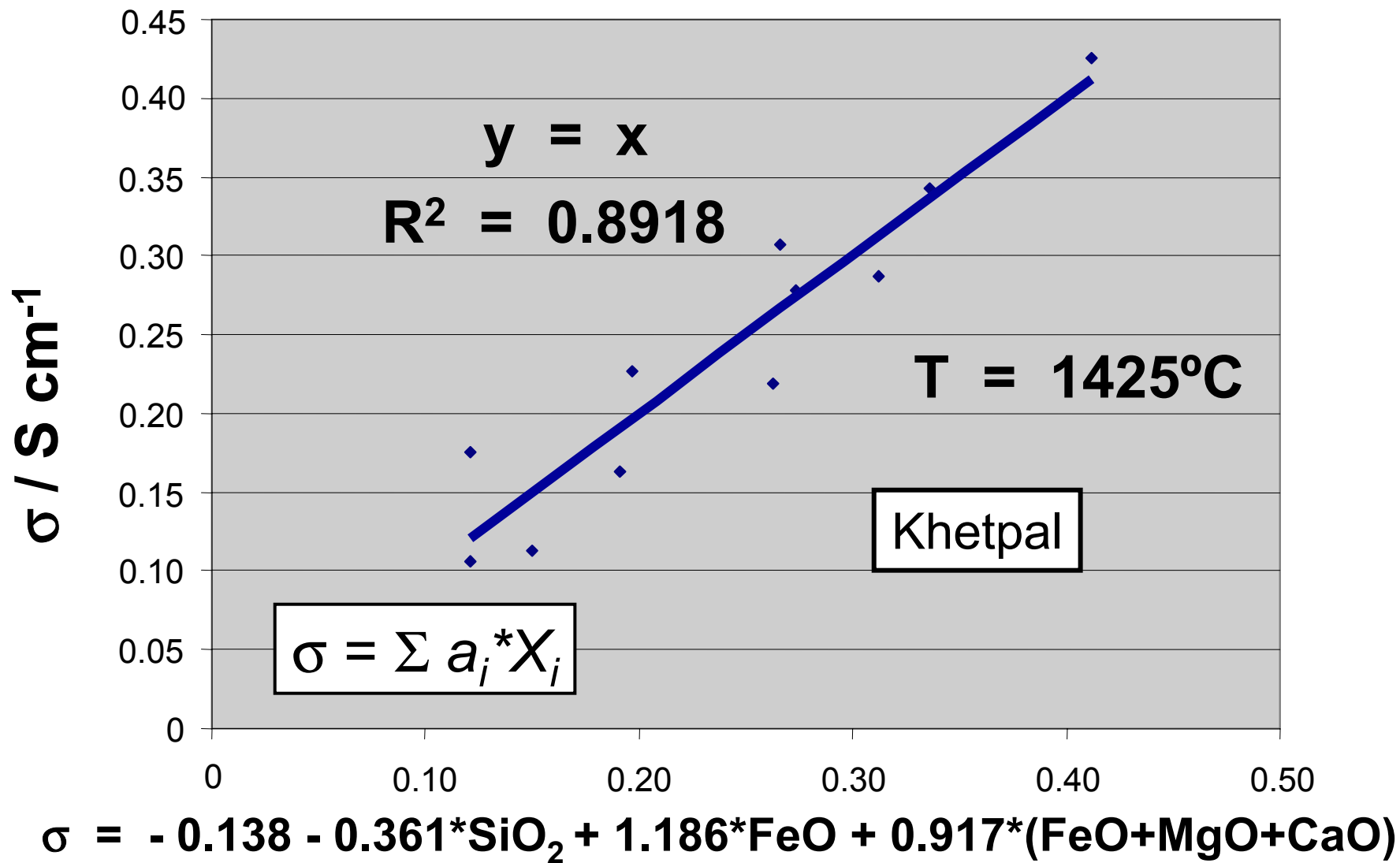

FeO acts as an electron donor

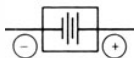
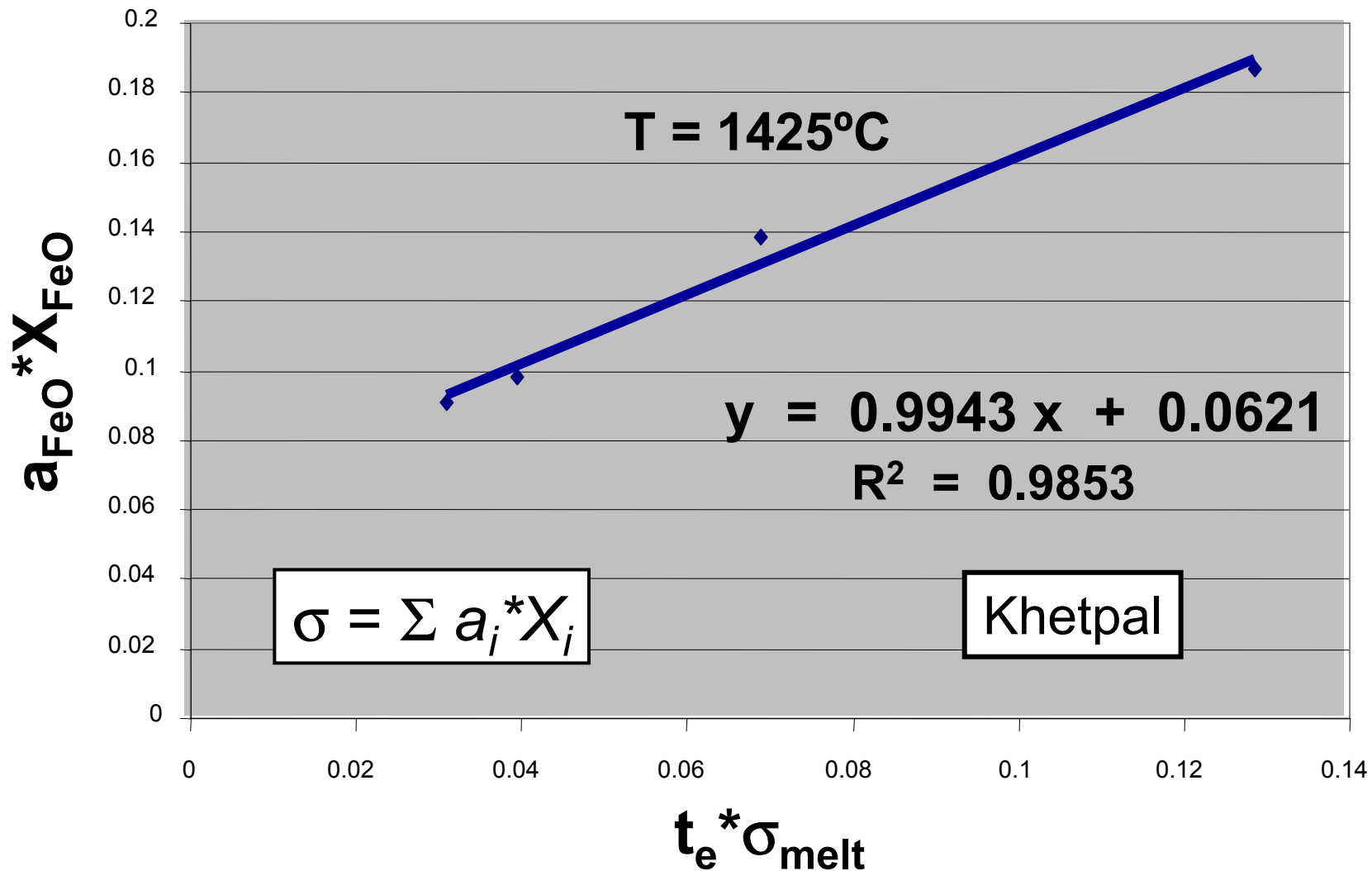

applicability to oxygen generation

daily oxygen requirement = 2.75 kg

Faradaic efficiency = 85% (based on t_{ionic})

current = 452 A

cell voltage = 2 V ($2.5 \times \Delta H_{\text{FeO}}$)

power supply = 904 W

current density = 5 A cm⁻²

electrode area = 90 cm⁻²



... in closing

- ☑ high-accuracy electrical conductivity and transference number measurements in molten oxides at extreme temperatures
- ☑ electrolytic production of breathable oxygen not unviable
- ☑ implications for fluxes and slags, e.g., welding, refining, & metallothermic reduction



acknowledgments



National **A**eronautics
& **S**pace **A**dministration



National **S**cience **F**oundation
Electric **P**ower **R**esearch **I**nstitute

