Internal Forces and Moments

3.1 Consequences of Equilibrium - The Truss Structure

We are ready to start talking business, to buy a loaf of bread. Up until now we have focused on the rudimentary basics of the language; the vocabulary of force, moment, couple and the syntax of static equilibrium of an isolated particle or extended body. This has been an abstract discourse for the most part. We want now to start speaking about “extended bodies” as *structural members*, as the building blocks of *truss structures*, *frame structures*, *shafts and columns* and the like. We want to be go beyond questions about forces and moments required to satisfy equilibrium and ask “...When will this structure break? Will it carry the prescribed loading?”

We will discover that, with our current language skills, we can only answer questions of this sort for one type of structure, the *truss structure*, and then only for a subset of all possible truss structures. To go further we will need to broaden our scope, beyond the requirements of force and moment equilibrium, and analyze the *deformations and displacements* of extended bodies in order to respond to questions about load carrying ability regardless of the type and complexity of the structure at hand - the subject of a subsequent chapter. Here we will go as far as we can go with the vocabulary and rules of syntax at our disposal. After all, the requirements of force and moment equilibrium still must be satisfied whatever structure we confront.

A *truss structure* is designed, fabricated, and assembled such that its members carry the loads in tension or compression. More abstractly, **a truss structure is made up of straight, two-force members, fastened together by frictionless pins; all loads are applied at the joints.**

Now, we all know that there is no such thing as a truly frictionless pin; you will not find them in a suppliers catalogue. And to require that the loads be applied at the joints alone seems a severe restriction. How can we ensure that this constraint is abided by in use?

We can't and, indeed, frictionless pins do not exist. This is not to say that there are not some ways of fastening members together that act more like frictionless pins than other ways.

What *does* exist inside a truss structure are forces and moments of a quite general nature but the forces of tension and compression within the straight members are the most important of all if the structure is designed, fabricated, and assembled according to accepted practice. That is, the loads within the members of a truss structure may be approximated by those obtained from an analysis of an abstract representation (as

straight, frictionless pinned members, loaded at the joints alone) of the structure. Indeed, this abstract representation is what serves as the basis for the design of the truss structure in the first place.

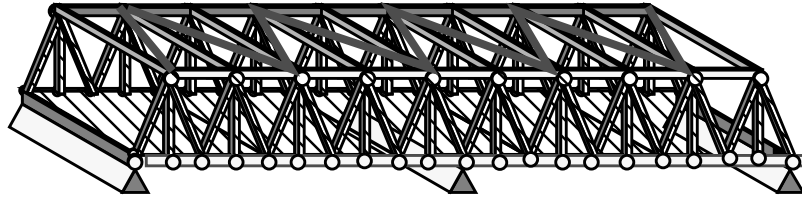

Any member of the structure shown above will, in our abstract mode of imagining, be in either tension or compression – a state of *uniaxial loading*. Think of having a pair of special eyeglasses – truss seeing glasses – that, when worn, enable you to see the frictionless pins joined by straight lines and vector forces applied at the joints. This is how we will usually sketch the truss structure, as you would see them through such magical glasses. If you imagine now taking out one of the members, say with square cross-section, still carrying the load, say tension, you would see something like what’s shown below:

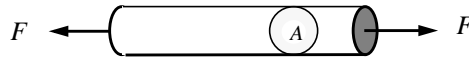

Now continue our imagining: Increase the applied loads slowly. The tension in this member will increase proportionally. Eventually, the member will fail. Often a structure fails at its joints. We rule out this possibility here, assuming that our joints have been *over-designed*. The way in which the member fails, as well as the tensile force at which it fails, depends upon two things: The cross-sectional area of the member and the material out of which it is made.

If it is grey cast iron with a cross sectional area of 1.0 in^2 , the member will *fracture*, break in two, when the tensile force approaches $25,000 \text{ lb}$. If it is made of aluminum alloy 2024-T4 and its area is 600 mm^2 it will *yield*, begin to deform *plastically*, when the tensile forces approaches $195,000 \text{ Newtons}$. In either case there is some magnitude of the tensile force we do not want to exceed if we wish to avoid failure.

Continue on with the thought experiment: Imagine that we replaced this member in our truss structure with another of the same length but twice the cross-sectional area. What tensile load can the member now carry before failure?

In this imaginary world, the tensile force required for failure will be twice what it was before. In other words, we take the measure of failure for a truss member in tension to be the *tensile (or compressive) stress* in the member where the stress is defined as the magnitude of the force divided by the cross-sectional area of the member. In this we assume that the force is *uniformly distributed* over the cross-sectional area as shown below.

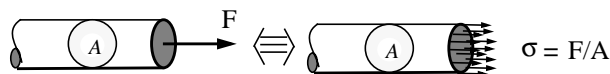

Further on we will take a closer look at how materials fail due to internal forces, not just tensile and compressive. For now we take it as an empirical observation and operational heuristic that to avoid fracture or yielding of a truss member we want to keep the **tensile or compressive stress** in the member below a certain value, a value which depends primarily upon the material out of which the member is made. (We will explore later on when we are justified taking a failure stress in uniaxial compression equal to the failure stress in uniaxial tension.) It will also depend upon what conventional practice has fixed for a *factor of safety*. Symbolically, we want

$$F/A < (F/A)_{\text{failure}} \quad \text{or} \quad \sigma < \sigma_{\text{failure}}$$

where I have introduced the symbol σ to designate the uniformly distributed stress.

Exercise 3.1

If the members of the truss structure of Exercise 2.7 are made of 2024-T4 Aluminum, hollow tubes of diameter 20.0 mm and wall thickness 2.0 mm , estimate the maximum load P you can apply before the structure yields.¹ In this take θ_A, θ_B to be $30^\circ, 60^\circ$ respectively

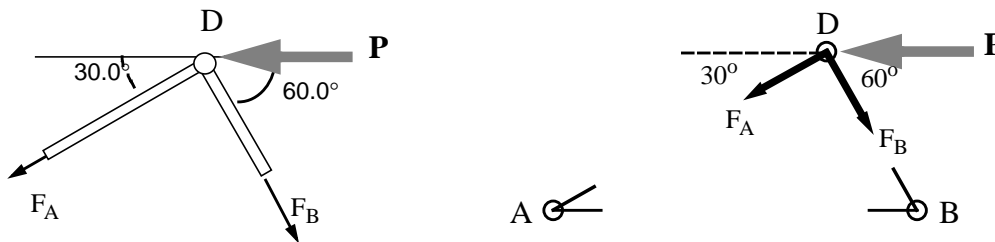

Rather than picking up where we left off in our analysis of Exercise 2.7., we make an alternate isolation, this time of joint, or *node D* showing the unknown member forces directed along the member. By convention, we assume that both members are in tension. If the value for a member force comes out to be negative, we conclude that the member is in compression rather than tension. This is an example of a convention often, but not always, adopted in the analysis and design of truss structures. You are free to violate this norm or set up your own but, beware: It is your responsibility to note the difference between your method and what we will take as conventional and understood without specification.

Force equilibrium of this *node as particle* then provides two scalar equations for the two scalar unknown member forces. We have

$$-F_A \cdot \cos 30^\circ + F_B \cdot \cos 60^\circ - P = 0 \quad -F_A \cdot \sin 30^\circ - F_B \cdot \sin 60^\circ = 0$$

1. Another failure mode, other than yielding, is possible: Member *AD* might *buckle*. We will attend to this possibility in the last chapter.

From these, we find that member AD is in *compression*, carrying a load of $(\sqrt{3}/2)P$ and member BD is in *tension*, carrying a load $P/2$. The stress in each member is the force divided by the cross-sectional area

$$A = \pi \cdot (20 \times 10^{-3}) \cdot (2 \times 10^{-3}) \text{m}^2 = 40\pi \times 10^{-6} \text{m}^2$$

where I have approximated the area of the cross-section of the thin-walled tube as a rectangle whose length is equal to the circumference of the tube and width equal to the wall thickness.

Now the compressive stress in member AD is greater in magnitude than the tensile stress in member BD – about 1.7 times greater – thus member AD will yield first. This defines the mode of failure. The *compressive stress in AD* is

$$\sigma = (\sqrt{3}/2) \cdot P/A$$

which we will say becomes excessive if it approaches 80% of the value of the stress at which 2024-T4 Aluminum begins to yield in uniaxial tension. The latter is listed as *325 MegaPascals* in the tables at the end of this volume. A Pascal is one Newton per Square meter. Mega is 10^6 . Note well how the dimensions of stress are the same as those of pressure, namely, force per unit area.

We estimate then, that the structure will fail, due to yielding of member AD , when

$$P = (2/\sqrt{3}) \cdot (0.80) \cdot (40\pi \times 10^{-6} \text{m}^2) \cdot (325 \times 10^6 \text{N/m}^2) = 37,700 \text{N}$$

I am going to now alter this structure by adding a third member CD . We might expect that this would *pick up some of the load*, enabling the application of a load P greater than that found above before the *onset of yielding*. We will discover that we cannot make this argument using our current language skills. We will find that we need new vocabulary and rules of syntax in order to do so. Let us see why.

Exercise 3.2

Show that if I add a third member to the structure of **Exercise 3.1** connecting node D to ground at C , the equations of static equilibrium do not suffice to define the tensile or compressive forces in the three members.

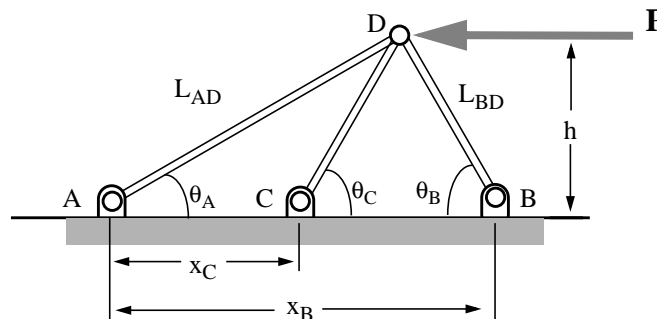

I isolate the system, starting as I did when I first encountered this structure, cutting out the whole structure from its supporting pins at A , B and C . The free body diagram above shows the direction of the

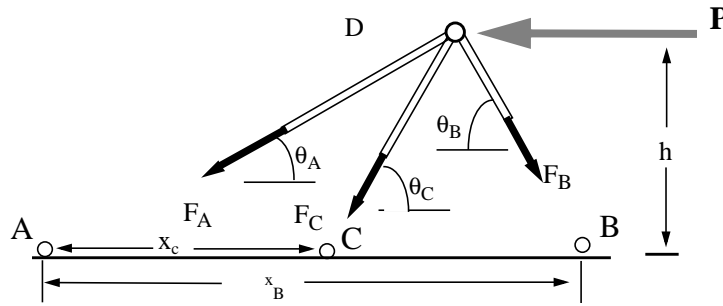

unknown member forces as along the members, a characteristic of this and every truss structure. Force equilibrium in the horizontal direction and vertical direction produces two scalar equations:

$$-F_A \cdot \cos \theta_A - F_C \cdot \cos \theta_C + F_B \cdot \cos \theta_B - P = 0$$

and

$$F_A \cdot \sin \theta_A + F_B \cdot \sin \theta_B + F_C \cdot \sin \theta_C = 0$$

At this point I note that the above can be read as two equations in three unknowns — the three forces in the members — presuming we are given the angles θ_A , θ_B , and θ_C , together with the applied load P . We clearly need another equation.

Summing moments about A I can write

$$x_B \cdot F_B \cdot \sin \theta_B + x_C \cdot F_C \cdot \sin \theta_C - h \cdot P = 0$$

where

$$x_C = L_{AD} \cdot \cos \theta_A - L_{CD} \cdot \cos \theta_C \quad \text{and} \quad x_B = L_{AD} \cdot \cos \theta_A + L_{BD} \cdot \cos \theta_B$$

and

$$h = L_{AD} \cdot \sin \theta_A = L_{CD} \cdot \sin \theta_C = L_{BD} \cdot \sin \theta_B$$

I now proceed to try to solve for the unknown member forces in terms of some or all of these presumed given geometrical parameters. First I write the distances x_C and x_B as

$$x_C = h \cdot [(\cos \theta_A / \sin \theta_A) - (\cos \theta_C / \sin \theta_C)] \quad \text{and} \quad x_B = h \cdot [(\cos \theta_A / \sin \theta_A) + (\cos \theta_B / \sin \theta_B)]$$

or

$$x_C = h \cdot \left[\frac{\sin(\theta_C - \theta_A)}{\sin\theta_A \cdot \sin\theta_C} \right] \quad \text{and} \quad x_B = h \cdot \left[\frac{\sin(\theta_A + \theta_B)}{\sin\theta_A \cdot \sin\theta_B} \right]$$

With these, the equation for moment equilibrium about A becomes after substituting for the x 's and canceling out the common factor h ,

$$F_B \cdot \sin(\theta_A + \theta_B) + F_C \cdot \sin(\theta_C - \theta_A) - P \cdot \sin\theta_A = 0$$

It appears, at first glance that we are in good shape, that we have three scalar equations – two from force equilibrium, this last from moment equilibrium – available to determine the three member forces, F_A , F_B and F_C . We proceed by eliminating F_A , one of our unknowns from the equations of force equilibrium. We will then be left with two equations – those we derive from force and moment equilibrium – for determining F_B and F_C .

We multiply the equation expressing force equilibrium in the horizontal direction by the factor $\sin\theta_A$, that expressing force equilibrium in the vertical direction by the factor $\cos\theta_A$ then add the two equations and obtain

$$F_B \cdot (\sin\theta_A \cdot \cos\theta_B + \cos\theta_A \cdot \sin\theta_B) + F_C \cdot (\sin\theta_C \cdot \cos\theta_A - \sin\theta_A \cdot \cos\theta_C) - P \cdot \sin\theta_A = 0$$

This can be written, using the appropriate trig identities,

$$F_B \cdot \sin(\theta_A + \theta_B) + F_C \cdot \sin(\theta_C - \theta_A) - P \cdot \sin\theta_A = 0$$

which is identical to the equation we obtained from operations on the equation of moment equilibrium about A above. This means we are up a creek. The equation of moment equilibrium gives us no new information we did not already have from the equations of force equilibrium. We say that the equation of moment equilibrium is linearly dependent upon the latter two equations. We cannot find a unique solution for the member forces. We say that **this system of equations is linearly dependent**. We say that **the problem is statically, or equilibrium, indeterminate**. The equations of equilibrium do *not* suffice to enable us to find a unique solution for the unknowns. Once again, the meaning of the word indeterminate is best illustrated by the fact that we can find many, many solutions for the member forces that satisfy equilibrium.

This time there are no special tricks, no special effects hidden in subsystems, that would enable us to go further. That's it. We can not solve the problem. Rather, we have solved the problem in that we have shown that the equations of equilibrium are insufficient to the task.

Observe

- That the forces in the members might depend upon how well a machinist has fabricated the additional member CD . Say he or she made it too short. Then, in order to assemble the structure, you are going to have to pull the node D down toward point C in order to fasten the new member to the others at D and to the ground at C . This will mean that the members will experience some tension or compression even when the applied load is zero¹! We say the structure is *preloaded*. The magnitudes of the preloads will depend upon the extent of the incompatibility of the length of the additional member with the distance between point C and D

- We don't need the third member if the load P never comes close to the failure load determined in the previous exercise. The third member is *redundant*. In fact, we could remove any *one* of the other two members and the remaining two would be able to support a load P of some significant magnitude. With three members we have a *redundant structure*. **A redundant structure is most often synonymous with a statically indeterminate system of equations.**

- I could have isolated joint D at the outset and immediately have recognized that only two linearly independent equations of equilibrium are available. Moment equilibrium would be *identically satisfied* since all force vectors intersect at a common point, at the node D .

In the so-called "real world", some truss structures are designed as redundant structures, some not. Why you might want one or the other is an interesting question. More about this later.

Statically determinate trusses can be quite complex, fully three-dimensional structures. They are important in their own right and we have all that we need to determine their member forces—namely, the requirements of static equilibrium.

Exercise 3.3

Construct a procedure for calculating the forces in all the members of the *statically determinate truss* shown below. In this take $\alpha = \sqrt{3}$

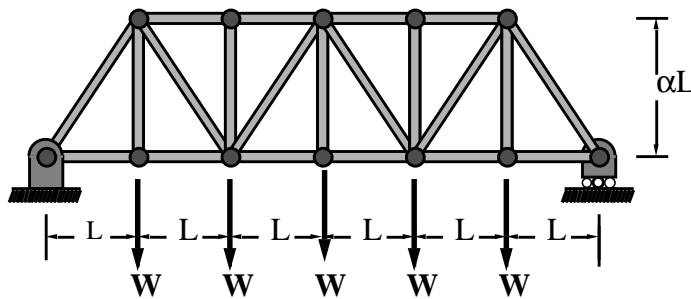

1. We begin with an isolation of the entire structure:

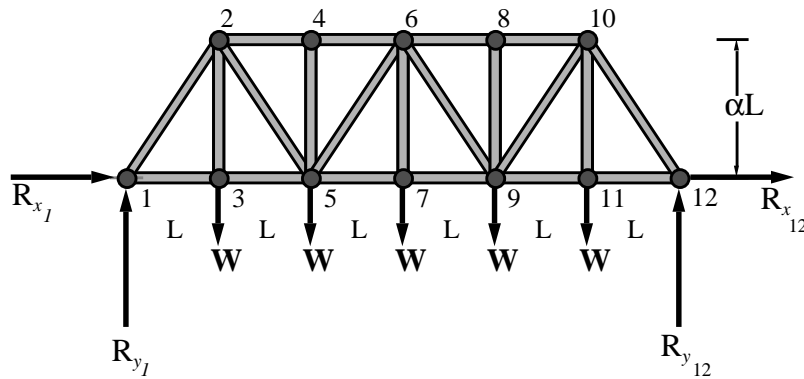

1. This is one reason why no engineering drawing of structural members is complete without the specification of tolerances.

2. Then we determine the reactions at the supports.

This is not always a necessity, as it is here, but generally it is good practice. Note all of the strange little circles and shadings at the support points at the left and right ends of the structure. The icon at the left end of the truss is to be read as meaning that:

- the joint is frictionless and
- the joint is restrained in both the horizontal and vertical direction, in fact, the joint can't move in any direction.

The icon at the right shows a frictionless pin at the joint but it itself is sitting on more frictionless pins. The latter indicate that the joint is free to move in the horizontal direction. This, in turn, means that the horizontal component of the reaction force at this joint, $R_{x_{12}}$ is zero, a fact crucial to the *determinancy* of the problem. The shading below the row of circles indicates that the joint is *not* free to move in the vertical direction.

From the symmetry of the applied loads, the total load of $5W$ is shared equally at the supports. Hence, the vertical components of the two reaction forces are

$$R_{y_1} = R_{y_{12}} = 5W/2.$$

Both of the horizontal components of the reaction forces at the two supports must be zero if one of them is zero. This follows from the requirement of force equilibrium applied to our isolation.

$$R_{x_1} = R_{x_{12}} = 0.$$

3. Isolate a joint at which but **two** member forces have yet to be determined and apply the equilibrium requirements to determine their values.

There are but two joints, the two support joints that qualify for consideration this first pass through the procedure. I choose to isolate the joint at the left support. Equilibrium of force of node # 1 in the horizontal and vertical direction yields the two scalar equations for the two unknown forces in members 1-2 and 1-3. In this we again assume the members are in tension. A negative result will then indicate the member is in compression. The proper way to speak of this feature of our isolation is to note how "the members in tension pull on the joint".

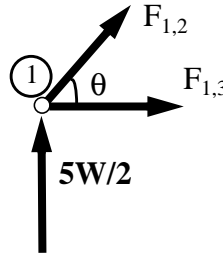

Equilibrium in the x direction and in the y direction then requires:

$$F_{1,2} \cdot \cos\theta + F_{1,3} = 0$$

$$F_{1,2} \cdot \sin\theta + (5/2) \cdot W = 0$$

where the $\tan\theta = \alpha$ and given $\alpha = \sqrt{3}$ so $\sin\theta = \sqrt{3}/2$ and $\cos\theta = 1/2$. These yield

$$F_{1,2} = -(5/\sqrt{3}) \cdot W$$

$$F_{1,3} = (5/2\sqrt{3}) \cdot W$$

The negative sign indicates that member 1-2 is in compression.

4. Repeat the previous step in the procedure.

Having found the forces in members 1,2 and 1,3, node, or joint, # 3 becomes a candidate for isolation.

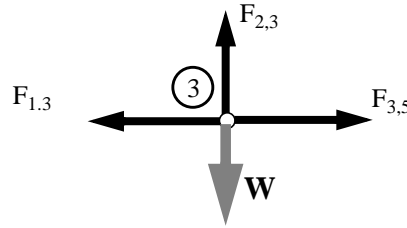

It shows but two unknown member forces intersecting at the node. Node # 12 remains a possibility as well. I choose node # 3. Force equilibrium yields

$$-F_{1,3} + F_{3,5} = 0 \quad \text{and} \quad +F_{2,3} - W = 0$$

Note how on the isolation I have, according to convention, assumed all member forces positive in tension. $F_{1,3}$ acts to the left, pulling on pin # 3. This force vector is the equal and opposite, internal reaction to the $F_{1,3}$ shown in the isolation of node # 1. With $F_{1,3} = (5/2\sqrt{3})W$ we have

$$F_{3,5} = (5/2\sqrt{3}) \cdot W \quad \text{and} \quad +F_{2,3} = W$$

These equations are thus, easily solved, and we go again, choosing either node # 2 or # 12 to isolate in the next step.

5. *Stopping rule: Stop when all member forces have been determined.*

This piece of machinery is called *the method of joints*. Statically determinate truss member forces can be produced using other, just as sure-fire, procedures. (See problem 3.1) The main point to note is that all the member forces in a truss can be determined *from equilibrium conditions alone* using a judiciously chosen sequence of isolations of the nodes **if and only if** the truss is statically determinate. That's a circular statement if there ever was one but you get the point¹.

1. Note how, if I were to add a redundant member connecting node #3 to node #4, I could no longer find the forces in the members joined at node #3 (nor those in the members joined at nodes #2 and #5). The problem would become equilibrium indeterminate

3.2 Internal Forces and Moments in Beams

A *beam* is a structural element like the truss member but, unlike the latter, it is designed, fabricated, and assembled to carry a load in *bending*¹. In this section we will go as far as we can go with our current vocabulary of force, couple, and moment and with our requirements of static equilibrium, attempting to explain what bending is, how a beam works, and even when it might fail.

3.2.1 The Cantilever according to Galileo

You, no doubt, know what a beam is in some sense, at least in some ordinary, everyday sense. Beams have been in use for a long time; indeed, there were beams before there were two-force members. The figure below shows a seventeenth century *cantilever beam*. It appears in a book written by Galileo, his *Dialogue Concerning Two New Sciences*.

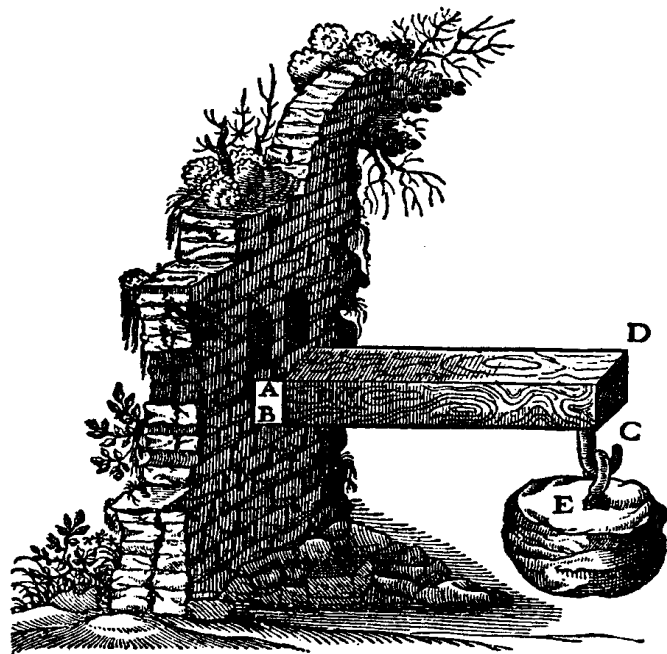

Galileo wanted to know when the cantilever beam would break. He asked: What weight, hung from the end of the beam at *C*, would cause failure? You might wonder about Galileo's state of mind when he posed the question. From the looks of the wall it is the latter whose failure he should be concerned with, not the beam. No. You are reading the figure incorrectly; you need to put on another special pair of eye-glasses that filter out the shrubbery and the decaying wall and allow you to see only a cantilever beam, rigidly attached to a rigid support at the end *AB*. These glasses will also be necessary in what follows, so keep them on.

1. Here is another circular statement illustrating the difficulty encountered in writing a dictionary which must necessarily turn in on itself.

Galileo had, earlier in his book, discussed the failure of what we would call a bar in uniaxial tension. In particular, he claimed and argued that the tensile force required for failure is proportional to the cross sectional area of the bar, just as we have done. We called the ratio of force to area a “stress”. Galileo did not use our language but he grasped, indeed, might be said to have invented the concept, at least with respect to this one very important trait – stress as a criterion for failure of a bar in tension. Galileo’s achievement in analyzing the *cantilever beam under an end load* lay in relating the end load at failure to the failure load of a bar in uniaxial tension. Of course the bar had to be made of the same material. His analysis went as follows:

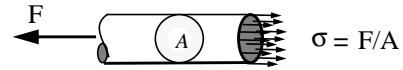

He imagined the beam to be an angular lever pivoted at B . At one end of the lever, at the end of the long arm BC was hung the weight W . Along the other shorter, vertical arm of the lever AB acted a horizontally directed, internal, tensile force, let us call it F_{AB} , which Galileo claimed acted at a point half way up the lever arm and provided the internal resistance to fracture. Look back at Galileo’s figure with your special glasses on. Focus on the beam. See now the internal resistance acting along a plane cut through the beam at AB . Forget the possibility of the wall loosening up at the root of the cantilever. Take a peek ahead at the next more modern figure if you are having trouble seeing the internal force resultant acting on the section AB .

For moment equilibrium about the point B one must have

$$(h/2)F_{AB} = W \cdot L$$

where I have set h equal to the height of the beam, AB , and L equal to the length of the beam, BC .

According to Galileo, the beam will fail when the ratio of F_{AB} to the cross sectional area reaches a particular, material specific value¹. This ratio is what we have called the failure stress in tension. From the above equation we see that, for members with the same cross section area, the end load, W , to cause failure of the member acting as a cantilever is much less than the load, F_{AB} , which causes failure of the member when loaded axially, as a truss member (by the factor of $(1/2)h/L$).

A more general result, for beams of rectangular cross section but different dimensions, is obtained if we express the end load at failure in terms of the failure stress in tension, i.e., σ_{failure} :

$$W_{\text{failure}} = \frac{1}{2}(h/L) \cdot bh \cdot \sigma_{\text{failure}} \quad \text{where} \quad \sigma_{\text{failure}} = F_{AB}|_{\text{failure}} / (bh)$$

and where I have introduced b for the breadth of the beam.

Observe:

- This is a quite general result. If one has determined the value of the ratio σ_{failure} for a specimen in tension, what we would call the failure stress in a tension test, then this one number provides, inserting it into the equation above, a way to compute the end load a cantilever beam, of arbitrary dimensions h , b and L , will support before failure.
- Galileo has done all of this without drawing an isolation, or free-body diagram!

1. Galileo mentions wood, glass, and other materials as possibilities.

- He is wrong, precisely **because he did not draw an isolation.**

To state he was wrong is a bit too strong. As we shall see, his achievement is real; he identified the underlying form of beam bending and its resistance to fracture. Let us see how far we can proceed by drawing an isolation and attempting to accommodate Galileo's story.

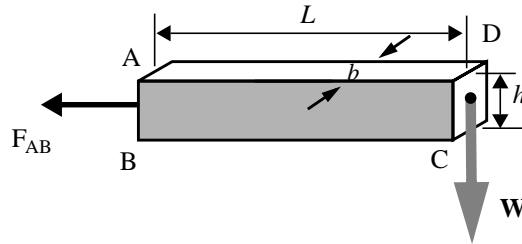

I have isolated the cantilever, cutting it at AB away from the rest of the beam nested in the wall. Here is where Galileo claims fracture will occur. I have shown the weight W at the end of the beam, acting downward. I have neglected the weight of the material out of which the beam itself is fabricated. Galileo did the same and even described how you could take the weight into account if desired. I have shown a force F_{AB} , the internal resistance, acting halfway up the distance AB .

Is this system in equilibrium? No. Force equilibrium is not satisfied and moment equilibrium about any other point but B is not satisfied. This is a consequence of the failure to satisfy force equilibrium. That is why he is wrong.

On the other hand, we honor his achievement. To see why, let us do our own isolation, and see how far we can go using the static equilibrium language skills we have learned to date.

We allow that there may exist at the *root of the cantilever*, at our cut AB , a force, F_V and a couple M_0 . We show only a vertical component of the internal reaction force since if there were any horizontal

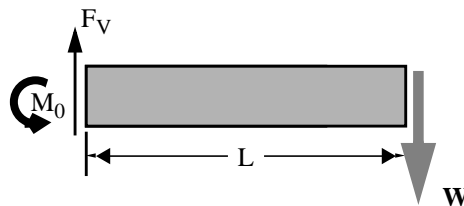

component, force equilibrium in the horizontal direction would not be satisfied. I show the couple acting positive counter clockwise, i.e., directed out of the plane of the paper.

Force equilibrium then yields

$$F_V - W = 0 \quad \text{or} \quad F_V = W$$

and moment equilibrium

And this is as far as we can go; we can solve for the vertical component of the reaction force at the root, F_V and for the couple (as we did in a prior exercise), M_0 , and that's it. But notice what has happened: There is no longer any horizontal force F_{AB} to compare to the value obtained in a tension test!

It appears we (and Galileo) are in serious trouble if our intent is to estimate when the beam will fail. Indeed, we can go no further.¹ This is as far as we can go with the requirements of static equilibrium.

Before pressing further with the beam, we consider another problem, — a truss structure much like those cantilevered crane arms you see operating in cities, raising steel and concrete in the construction of many storied buildings. We pose the following problem.

Exercise 3.4

Show that truss member AC carries a tensile load of $8W$, the diagonal member BC a compressive load of $\sqrt{2} W$, and member BD a compressive load of $7W$. Then show that these three forces are equivalent to a vertical force of magnitude W and a couple directed counter clockwise of magnitude WL .

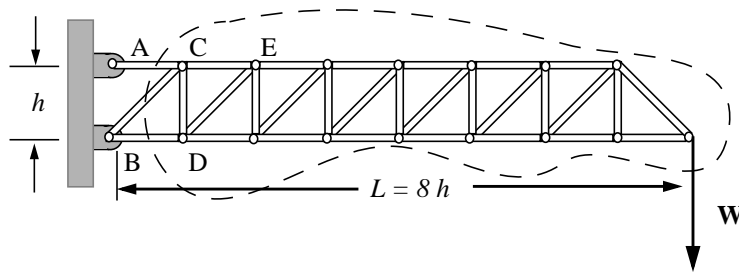

We could, at this point, embark on a *method of joints*, working our way from the right-most node, from which the weight W is suspended, to the left, node by node, until we reach the two nodes at the support pins at the wall. We will not adopt that time consuming procedure but take a short cut. We cut the structure away from the supports at the wall, just to the right of the points A and B , and construct the isolation shown below:

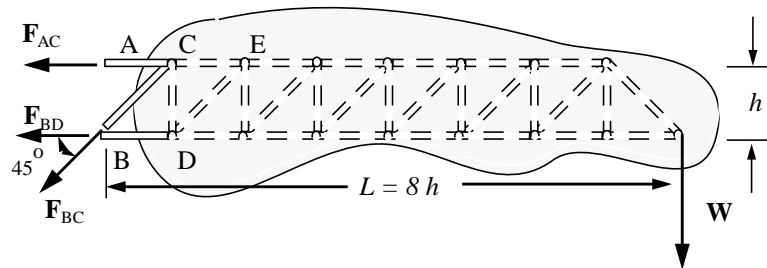

The diagram shows that I have taken the unknown, member forces to be positive in tension; F_{AC} and F_{BC} are shown pulling on node C and F_{BD} pulling on node D according to my usual convention. Force equilibrium in the horizontal and vertical directions respectively gives

$$-F_{AC} - (\sqrt{2}/2) \cdot F_{BC} - F_{BD} = 0 \quad \text{and} \quad -(\sqrt{2}/2)F_{BC} - W = 0$$

1. That is, if our criterion for failure is stated in terms of a maximum tensile (or compressive) stress, we can not say when the beam would fail. If our failure criterion was stated in terms of maximum bending moment, we could say when the beam would fail. But this would be a very special rule, applicable only for beams with identical cross sections and of the same material.

while moment equilibrium about point B , taking counter clockwise as positive yields

$$h \cdot F_{AC} - (8h) \cdot W = 0$$

Solution produces the required result, namely

$$F_{AC} = 8W; \quad F_{BC} = -\sqrt{2}W; \quad F_{BD} = -7W$$

The negative sign in the result for F_{BC} means that the internal force is oppositely directed from what was assumed in drawing the free-body diagram; the member is in *compression* rather than tension. So too for member BD ; it is also in compression. The three member forces are shown compressive or tensile according to the solution, in the isolation below, at the left. In the middle we show a statically equivalent system, having resolved the compressive force in BC into a vertical component, magnitude W , and a horizontal component magnitude W , then summing the latter with the horizontal force $7W$. On the right we show a statically equivalent system acting at the same section, AB – a vertical force of magnitude W and a couple of magnitude $WL = 8Wh$ directed counter clockwise.

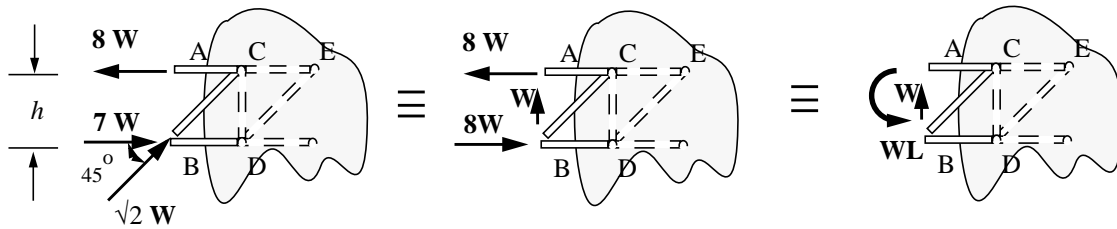

Observe:

- The identity of this truss structure with the cantilever beam of Galileo is to be noted. In particular, note how the moment of the weight W about the point B is balanced by the couple WL acting at the section AB . The two equal and opposite forces of magnitude $8W$ separated by the distance $h = L/8$ are equivalent to the couple WL .
- The most important member forces, those largest in magnitude, are the two members AC and BD . The top member AC is in tension, carrying $8W$, the bottom member BD in compression, carrying $7W$. The load in the diagonal member is relatively small in magnitude; it carries $1.4W$ in compression.
- Note if I were to add more *bays* to the structure, extending the truss out to the right from $8h$ to $10h$, to even $100h$, the tension and compression in the top and bottom members grow accordingly and approach the same magnitude. If $L = 100h$, then $F_{AC} = 100W$, $F_{BD} = 99W$, while the force in the diagonal member is, as before, $1.4W$ in compression! Its magnitude relative to the aforementioned tension and compression becomes less and less.

We faulted Galileo for not recognizing that there must be a vertical, reaction force at the root of the cantilever. We see now that maybe he just ignored it because he knew from his (faulty)¹ analysis that it was

1. We see how the question of evaluating Galileo's work as correct or faulty becomes complex once we move beyond the usual text-book, hagiographic citation and try to understand what he actually did using his writings as a primary source. See Kuhn, THE STRUCTURE OF SCIENTIFIC REVOLUTIONS, for more on this score.

small relative to the internal forces acting normal to the cross section at AB . Here is his achievement: he saw that the mechanism responsible for providing resistance to bending within a beam is the tension (and compression) of its longitudinal fibers.

Exercise 3.5

A force per unit area, a stress σ , acts over the cross section AB as shown below. It is horizontally directed and varies with vertical position on AB according to

$$\sigma(y) = c \cdot y^n \quad \quad \quad -(h/2) \leq y \leq (h/2)$$

In this, c is a constant and n a positive integer.

If the exponent n is odd *show that*

- (a) this stress distribution is equivalent to a couple alone (no resultant force), and
- (b) the constant c , in terms of the couple, say M_0 , may be expressed as

$$c = (n + 2) \cdot M_0 / [2b \cdot (h/2)^{n+2}]$$

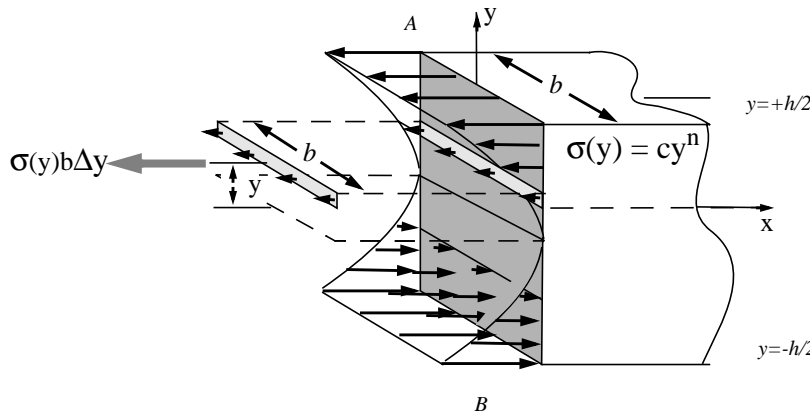

First, the *resultant force*: A *differential element of force*, $\Delta F = \sigma(y)b\Delta y$ acts on each differential element of the cross section AB between the limits $y = \pm h/2$. Note the dimensions of the quantities on the right: σ is a force per unit area; b a length and so too Δy ; their product then is a force alone. The *resultant force*, F , is the sum of all these differential elements of force, hence

$$F = \int_{-h/2}^{h/2} \sigma(y)b dy = c \int_{-h/2}^{h/2} y^n \cdot b dy$$

If the exponent n is odd, we are presented with the integral of an odd function, - $\sigma(y) = \sigma(-y)$, between symmetric limits. The sum, in this case, must be zero. Hence the resultant force is zero.

The resultant moment is obtained by summing up all the differential elements of moment due to the differential elements of force. The resultant moment will be a couple; indeed, it can be pictured as the sum of

the couples due to a differential element of force acting at $+y$ and a paired differential element of force, oppositely directed, acting at $-y$. We can write, as long as n is odd

$$M_0 = 2 \int_0^{h/2} y \cdot \sigma(y) b dy = 2c \int_0^{h/2} y^{n+1} \cdot b dy$$

Carrying out the integration, we obtain

$$M_0 = \frac{2cb}{(n+2)} \cdot (h/2)^{n+2}$$

So c can be expressed in terms of M_0 as

$$c = (n+2) \cdot M_0 / [2b \cdot (h/2)^{n+2}]$$

as we were asked to show.

Now we imagine the section AB to be a section at the root of Galileo's cantilever. We might then, following Galileo, claim that if the maximum value of this stress, which is engendered at $y = +h/2$, reaches the failure stress in a tension test then the cantilever will fail. At the top of the beam the maximum stress expressed in terms of M_0 is found to be, using our result for c ,

$$\sigma(y) = 2(n+2) \cdot M_0 / (bh^2)$$

Now observe:

- The dimensions are correct: σ , a stress, is a force per unit area. The dimensions of the right hand side are the same - the ratio of force to length squared.
- There are many possible odd values of n each of which will give a different value for the maximum stress σ at the top of the beam. The problem, in short, is *statically indeterminate*. We cannot define a unique stress distribution satisfying moment equilibrium nor conclude when the beam will fail.
- If we **arbitrarily choose** $n = 1$, i.e., a *linear distribution of stress* across the cross section AB , and set $M_0 = WL$, the moment at the root of an endloaded cantilever, we find that the maximum stress at $y = h/2$ is

$$\sigma|_{\max} = 6 \cdot (L/h) \cdot (W/bh)$$

Note the factor L/h : As we increase the ratio of length to depth while holding the cross sectional area, bh , constant — say (L/h) increases from 8 to 10 to even 100 — the maximum stress is magnified accordingly. This “levering action” of the beam in bending holds for other values of the exponent n as well! We must credit Galileo with seeing the cantilever beam as an angular lever. Perhaps the deficiency of his analysis is rooted in his not being conversant with

the concept of couple, just as students learning engineering mechanics today, three hundred years later, will err in their analyses, unable, or unwilling, to grapple with, and appropriate for their own use, the moment due to two, or many pairs of, equal and opposite forces as a thing in itself.

- If we compare this result with what Galileo obtained, identifying σ_{maximum} above with σ_{failure} of the member in tension, we have a factor of 6 where Galileo shows a factor of 2. That is, from the last equation, we solve for W with $\sigma_{\text{maximum}} = \sigma_{\text{failure}}$ and find

$$W_{\text{failure}} = \frac{1}{6}(h/L) \cdot bh \cdot \sigma_{\text{failure}}$$

- The beam is a redundant structure in the sense that we can take material out of the beam and still be left with a coherent and usable structure. For example, we might *mill* away material, cutting into the sides, the whole length of the beam as shown below and still be left with a stable and possibly more *efficient* structure —A beam requiring less material, hence less cost, yet able to support the design loads.

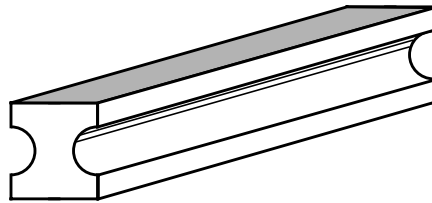

Exercise 3.6

The cross section of an *I beam* looks like an "I". The top and bottom parts of the "I" are called the *flanges*; the vertical, middle part is called the *web*.

If you assume that:

- i) the web carries no load, no *normal* stress
- ii) a uniformly distributed normal stress is carried by the top flange
- iii) a uniformly distributed normal stress is carried by the bottom flange
- iv) the top and bottom flanges have equal cross sectional areas.

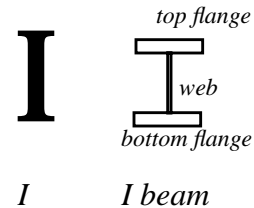

then show that

- a) the resultant force, acting in the direction of the length of the beam is zero only if the stress is tensile in one of the flanges and compressive in the other and they are equal in magnitude;
- b) in this case, the resultant moment, about an axis perpendicular to the web, is given by

$$M_0 = h \cdot (bt) \cdot \sigma$$

where h is the height of the cross section, b the breadth of the flanges, t their thickness.

The figure at the right shows our I beam. Actually it is an abstraction of an I beam. Our I beam, with its paper thin web, unable to carry any stress, would fail immediately.¹

But our abstraction is not useless; it is an approximation to the way an I beam carries a load in bending. Furthermore, it is a *conservative* approximation in the sense that if the web *does* help carry the load (as it does), then the stress levels we obtain from our analysis, our model, should be greater than those seen by the flanges in practice.

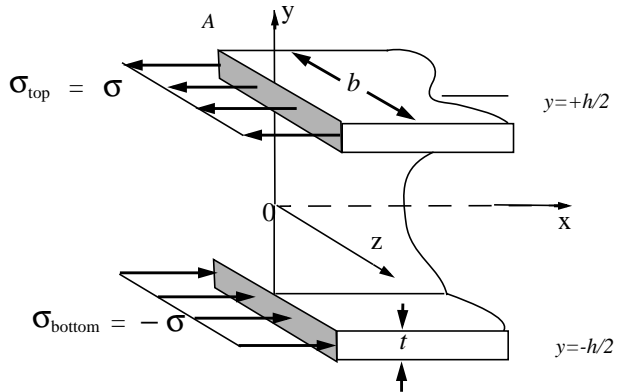

In a sense, we are taking advantage of the indeterminacy of the problem — the problem of determining the stress distribution over the cross section of a beam in terms of the applied loading — to get some estimate of the stresses generated in an I beam. What we are asked to show in a) and b) is that the requirements of static equilibrium may be satisfied by this assumed stress distribution. (We don't worry at this point, about force equilibrium in the vertical direction).

The figure shows the top flange in tension and the bottom in compression. According to the usual convention, we take a tensile stress as positive, a compressive stress as negative. It should be clear that there is no resultant force in the horizontal direction given the conditions i) through iv). That is, force equilibrium in the (negative) x direction yields

$$\sigma_{\text{top}} \cdot (bt) + \sigma_{\text{bottom}} \cdot (bt) = 0 \quad \text{if} \quad \sigma_{\text{bottom}} = -\sigma_{\text{top}}$$

The resultant moment is *not* zero. The resultant moment about the Oz axis, taking them counter clockwise, is just

$$M_0 = \sigma_{\text{top}} \cdot bt \cdot (h/2) - \sigma_{\text{bottom}} \cdot bt \cdot (h/2) = 2\sigma_{\text{top}} \cdot bt \cdot (h/2) = \sigma \cdot bth$$

where I have set $\sigma_{\text{top}} = \sigma$ and $\sigma_{\text{bottom}} = -\sigma$.

With this result, we can estimate the maximum stresses in the top and bottom flanges of an I beam. We can write, if we think of M_0 as balancing the end load W of our cantilever of length L so that we can set $M_0 = WL$,

$$\sigma_{\text{max}} = (L/h) \cdot (W/bt)$$

This should be compared with results obtained earlier for a beam with a rectangular cross section.

We can not resolve the indeterminacy of the problem and determine when an I beam, or any beam for that matter, will fail until we can pin down just what normal stress distribution over the cross section is

1. No I beam would be fabricated with the right-angled, sharp, interior corners shown in the figure; besides being costly, such features might, depending upon how the beam is loaded, engender *stress concentrations* — high local stress levels.

produced by an internal moment. For this we must consider the deformation of the beam, how the beam deforms due to the internal forces and moments. This is the focus of the next chapter.

Still, before going on to that topic, we will find it useful to pursue the behavior of beams further and explore how the *shear force* and *bending moment* change with position along a span. Knowing these internal forces and moments will be prerequisite to evaluating internal stresses acting at any point within a beam.

3.2.2 Shear Force and Bending Moment in Beams

Indeed, we will be bold and state straight out, as conjecture informed by our study of Galileo's work, that failure of a beam in bending will be due to an excessive bending moment. Our task then, when confronted with a beam, is to determine *the bending moment distribution* that is, how it varies along the span so that we can ascertain the section where the maximum bending moment occurs.

But first, a necessary digression to discuss sign conventions as they apply to internal stresses, internal forces, and internal moments. I reconsider the case of a bar in uniaxial tension but now allow the internal stress to vary along the bar. A uniform, solid bar of rectangular cross section, suspended from above and hanging vertically, loaded by its own weight will serve as a vehicle for explanation.

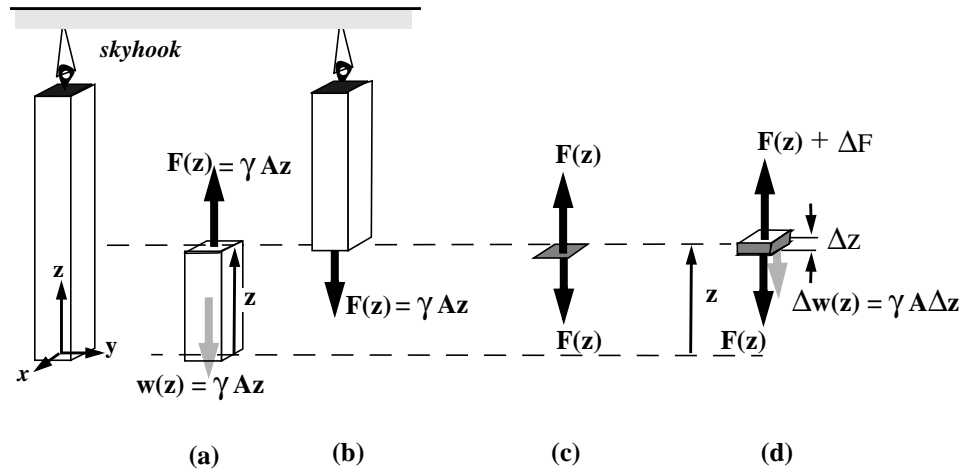

The section shown at (a) is a true free body diagram of a portion of the bar: the section has length "z", so in that sense it is of arbitrary length. The section experiences a gravitational force acting vertically downward; its magnitude is given by the product of the weight density of the section, γ , say in pounds per cubic inch, and the volume of the section which, in turn, is equal to the product of the cross sectional area, A, and the length, z. At the top of the section, where it has been "cut" away from the rest above, an internal, tensile force acts which, if force equilibrium is to be satisfied, must be equal to the weight of the section, $w(z)$. **By convention we say that this force, a tensile force, is positive.**

The section of the bar shown at (b) is not a true free body diagram since it is not cut free of all supports (and the force due to gravity, acting on the section, is not shown). But what it *does* show is the "equal and opposite reaction" to the force acting internally at the cut section, $F(z)$.

The section of the bar shown at (c) is *infinitely thin*. It too is in tension. We speak of the tensile force at the point of the cut, at the distance z from the free end. What at first glance appear to be two forces acting at the section — one directed upward, the other downward — are, in fact, one and the same single internal force. They are both positive and have the same magnitude.

To claim that these two oppositely directed forces are the same force can create confusion in the minds of those unschooled in the business of equal and opposite reactions; but that's precisely what they are. The best way to avoid confusion is to include in the definition of the direction of a positive internal force, some specification of the surface upon which the force acts, best fixed by the direction of *the outward normal* to the surface. This we will do. In defining a positive truss member force, we say the force is positive if it acts on a surface whose outward pointing normal is in the same direction as the force acting on the surface. The force shown above is then a positive internal force — a tension.

The section shown at (d) is a *differential section (or element)*. Here the same tensile force acts at z (directed downward) but it is *not* equal in magnitude to the tensile force acting at $z+\Delta z$, acting upward at the top of the element. The difference between the two forces is due to the weight of the element, $\Delta w(z)$.

To establish a convention for the shear force and bending moment internal to a beam, we take a similar approach. As an example, we take our now familiar cantilever beam and make an isolation of a section of span starting at some arbitrary distance x out from the root and ending at the right end, at $x = L$. But instead of an end load, we consider the internal forces and moments due to the weight of the beam itself. Figure (a) shows the magnitude of the total weight of the section acting vertically downward due to the uniformly distributed load per unit length, γA , where γ is the weight density of the material and A the cross-sectional area of the beam.

The section is a true free body diagram of a portion of the beam: the section has length $L-x$, so in that sense it is of arbitrary length. At the left of the section, where it has been "cut" away from the rest of the beam which is attached to the wall, we show an internal force and (bending) moment at x . We take it as a convention, one that we will adhere to throughout the remainder of this text, that **the shear force and the bending moment are positive as shown**. We designate the shear force by V , following tradition, and the bending moment by M_b .

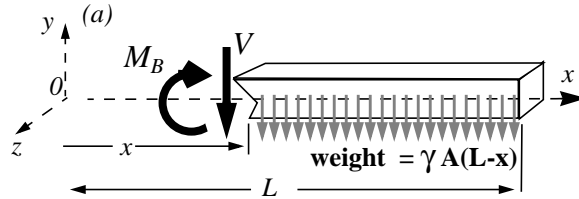

Now this particular convention requires elaboration: First consider the rest of the cantilever beam that we cut away. Figure (b) shows the equal and opposite reactions to the internal force and moment shown on our free body diagram in figure (a). (b) is not a true free body diagram since it is not cut free of all supports and the force due to gravity is not shown.

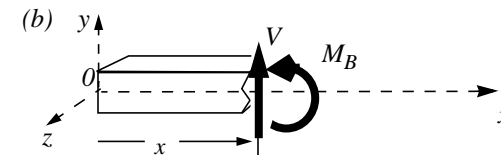

The section of the beam shown at (c) is infinitely thin. Here, what appears to be two forces is in fact one and the same internal force — the shear force, V , acting at the section x . They are both positive and have the same magnitude. Similarly what appears to be two moments is in fact one and the same internal moment — the bending moment, M_B , acting at the position x .

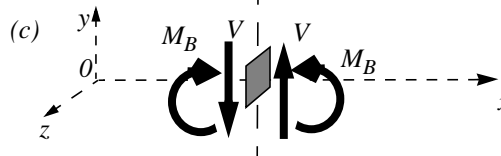

We show a positive shear force acting on the left face, a face with an outward normal pointing in the **negative** x direction, acting downward in the a **negative** y direction. It's equal and opposite reaction, the **same** shear force, is shown acting on the right face, a face with an outward normal pointing in the **positive** x direction, acting upward in a **positive** y direction. Our convention can then be stated as follows: **A positive shear force acts on a positive face in a positive coordinate direction or on a negative face in a negative coordinate direction.**

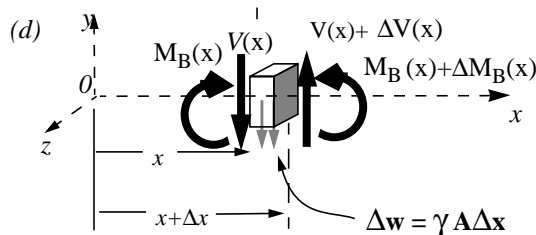

A **positive face** is short for a **face whose outward normal is in a positive coordinate direction**. The convention for positive bending moment is the same but now the direction of the moment is specified according to the right hand rule. We see that on the positive x face, the bending moment is positive if it is directed along the positive z axis. **A positive bending moment acts on a positive face in a positive coordinate direction or on a negative face in a negative coordinate direction.** *Warning:* Other textbooks use other conventions. It's best to indicate your convention on all exercises, including in your graphical displays the sketch to the right.

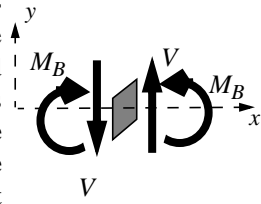

Exercise 3.7

Construct a graph that shows how the bending moment varies with distance along the end-loaded, cantilever beam. Construct another that shows how the internal force acting on any transverse section, the *transverse shear force* varies.

With all of this conventional apparatus, we can proceed to determine the shear force and bending moment which act internally at the section x along the end-loaded cantilever beam. In this, we neglect the weight of the beam. The load at the end, W , is assumed to be much greater. Otherwise, our free body diagram looks very much like figure (a) on the previous page: Force equilibrium gives but one equation

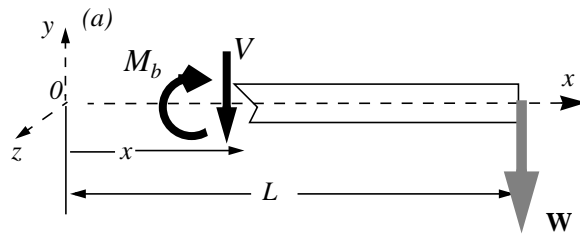

$$-V - W = 0$$

while moment equilibrium, taken about a point anywhere along the section at x gives, assuming a couple or moment is positive if it tends to rotate the isolated body counter clockwise

$$-M_b - W \cdot (L - x) = 0$$

The shear force is then a constant; it does not vary as we move along the beam, while the bending moment varies linearly with position along the beam, i.e.,

$$V = -W \quad \text{and} \quad M_b = -W \cdot (L - x)$$

. These two functions are plotted to the right, along with a sketch of the endloaded cantilever; these are the required constructions.

Some observations are in order:

- The shear force is constant and equal to the end load W but it is negative according to our convention.
- The maximum bending moment occurs at the root of the cantilever, at $x=0$; this is where failure is most likely to occur, as Galileo was keen to see. It too is negative according to our convention.
- The shear force is the negative of the slope of the bending moment distribution. That is

$$V(x) = - dM_b(x)/dx$$

- If, instead of isolating a portion of the beam to the **right** of the station x , we had isolated the portion to the **left** of the station x , we could have solved the problem but we would have had to have first evaluated the reactions at the wall.
- The isolation shown at the right and the application of force and moment equilibrium produce the same shear force and bending moment distribution as above. Note that the reactions shown at the wall, at $x=0$, are displayed according to their true directions; they can be considered the applied forces for this alternate, free body diagram.

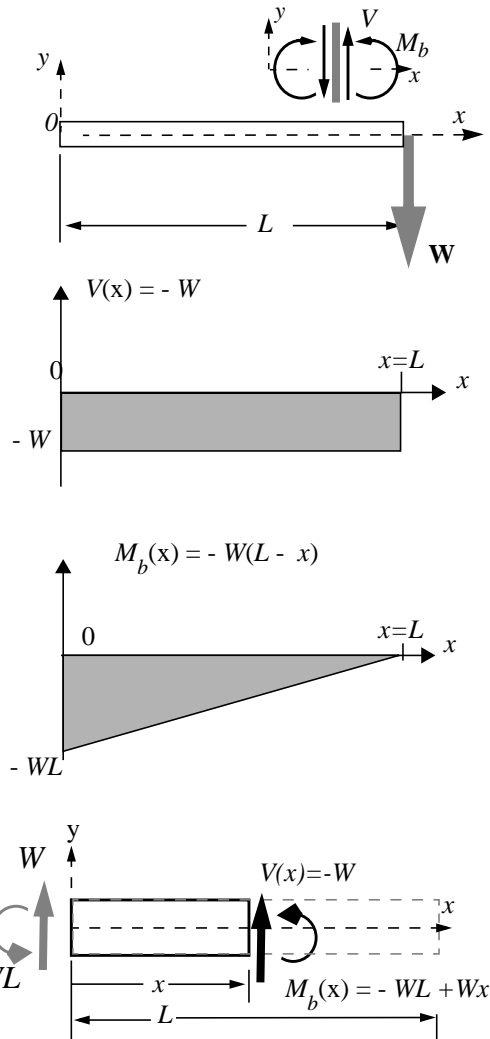

Exercise 3.8

Show that for the uniformly loaded, beam simply supported at its ends, the following differential relationships among the distributed load w_0 , the shear force $V(x)$, and the bending moment $M_b(x)$, hold true, namely:

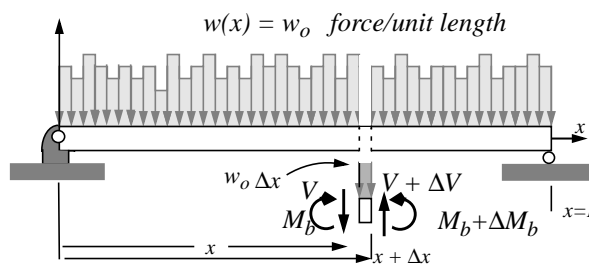

$$\frac{dV}{dx} = w_0 \quad \text{and} \quad \frac{dM_b}{dx} = -V$$

The differential relations among the shear force, $V(x)$, the bending moment, $M_b(x)$ and the distributed load w_0 are obtained from imagining a short, differential element of the beam of length Δx , cut out from the beam at some distance x . In this particular problem we are given a uniformly distributed load. Our derivation, however, goes through in the same way if w_0 is not constant but varies with x , the distance along the span. The relationship between the shear force and $w(x)$ would be the same.

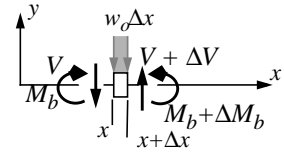

Such an element is shown above. **Note the difference between this differential element sketched here and the pictures drawn in defining a convention for positive shear force and bending moment:** Compare figures (c) and (d) on page 73. They are alike but they are to be read differently. The sketch used in defining our convention shows the internal force and moment at a **point** along the span of the beam; the sketch above and in (d) shows how the internal force and moment change over a small, but finite, length of span – over a **differential element**.

Focusing on the isolation of this differential element of the beam, force equilibrium requires

and moment equilibrium, about the point x , counter clockwise positive, yields

$$-M_b(x) - w_0 \cdot \Delta x \cdot (\Delta x/2) + (V + \Delta V) \cdot \Delta x + M_b + \Delta M_b = 0$$

We simplify, divide by Δx , let Δx approach zero and obtain for the ratios $\Delta V/\Delta x$ and $\Delta M_b/\Delta x$ in the limit

$$\frac{dV}{dx} = -w_0 \quad \text{and} \quad \frac{dM_b}{dx} = V$$

as was desired.

Note how, because the factor Δx appears twice in the w_0 term in the equation of moment equilibrium, it *drops out* upon going to the limit. We say it is *second order* relative to the other *leading order* terms which contain but a single factor Δx . The latter are *leading order* after we have canceled out the M_b , $-M_b$ terms. Knowing well the sign convention for positive shear force and bending moment is critical to making a correct reading of these differential equations. These general equations themselves — again, w_0 could be a function of x , $w(x)$, and our derivation would remain the same —s can be extremely useful in constructing shear force and bending moment distributions. That’s why I’ve placed a box around them.

For example we might attempt to construct the shear force and bending moment distributions by seeking integrals for these two, first order, differential equations. We would obtain, since w_0 is a constant

$$V(x) = -w_0 \cdot x + C_1 \quad \text{and} \quad M_b(x) = -w_0 \cdot (x^2/2) + C_1 \cdot x + C_2$$

But how to evaluate the two constants of integration? To do so we must know values for the shear force and bending moment at some x position, or positions, along the span.

Now, for our particular situation, we must have the bending moment vanish at the ends of the beam since there they are *simply supported* — that is, the supports offer no resistance to rotation hence the internal moments at the ends must be zero. This is best shown by an isolation in the vicinity of one of the two ends.

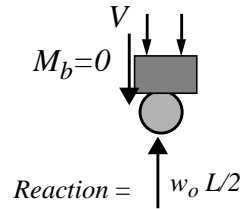

We require, then, that the following two *boundary conditions* be satisfied, namely

$$\text{at } x=0, \quad M_b = 0 \quad \text{and at } x=L, \quad M_b = 0$$

These two yield the following expressions for the two constants of integration, C_1 and C_2 .

$$C_1 = -w_0 \cdot (L/2) \quad \text{and} \quad C_2 = 0$$

and our results for the shear force and bending moment distributions become:

$$V(x) = w_0 \cdot (x - L/2)$$

$$M_b(x) = \frac{w_0 L^2}{2} \cdot [(x/L)^2 - (x/L)]$$

Unfortunately, this way of determining the shear force and bending moment distributions within a beam does not work so well when one is confronted with concentrated, point loads or segments of distributed loads. In fact, while it works fine for a continuous, distributed load over the full span of a beam, as is the case here, evaluating the constants of integration becomes cumbersome in most other cases. Why this is so will be explored a bit further on.

Given this, best practice is to determine the shear force and bending moment distributions from an isolation, or sequence of isolations, of portion(s) of the beam. The differential relationships then provide a useful check on our work. Here is how to proceed:

We first determine the reactions at the supports at the left and right ends of the span.

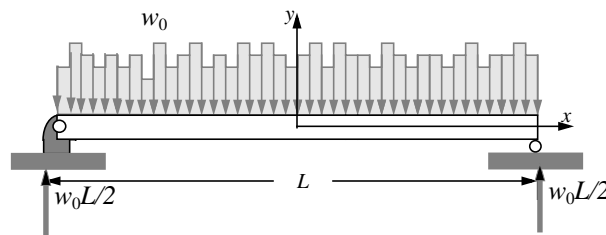

Note how I have re-positioned the axis system to take advantage of symmetry.¹

1. Note how the loading looks a bit jagged; it is not really a constant, as we move along the beam. While the effects of this "smoothing" of the applied load can not really be determined without some analysis which allows for the varying load, we note that the bending moment is obtained from an integration, twice over, of the distributed load. Integration is a smoothing operation. We explore this situation further on.

Symmetry suggests, and a free body diagram of the entire beam together with application of force and moment equilibrium would show, that the horizontal reactions at the ends are zero and the vertical reactions are the same, namely $w_0 L/2$.

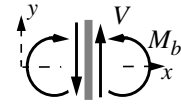

We isolate a portion of the beam to the right of some arbitrarily chosen station x . The choice of this section is not quite arbitrary: We made a cut at a positive x , a practice highly recommended to avoid sign confusions when writing out expressions for distances along the span in applying moment equilibrium.

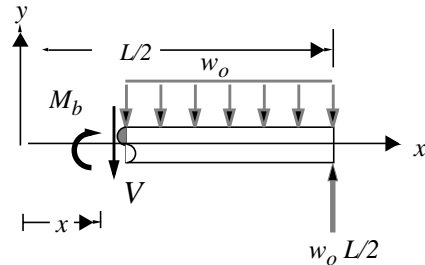

Below right, we show the same isolation but have replaced the load w_0 distributed over the portion of the span x to $L/2$, by an equivalent system, namely a force of magnitude $w_0[(L/2)-x]$ acting downward through a point located midway x to $L/2$. Applying force equilibrium to the isolation at the right yields:

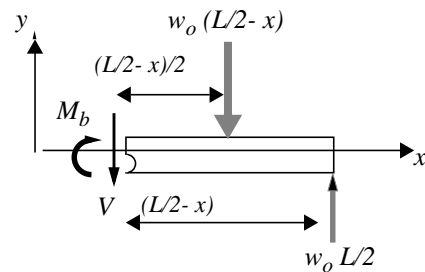

$$-V(x) - w_0 \cdot [(L/2) - x] + w_0 \cdot (L/2) = 0$$

while taking moments about the point x , counter clockwise positive, yields

$$-M_b(x) - w_0 \cdot [(L/2) - x][(L/2) - x]/2 + (w_0 L/2)[(L/2) - x] = 0$$

Solution of these yields the shear force and bending moment distributions shown below. We show the uniform load distribution as well.

$$w(x) = w_0$$

$$V(x) = w_0 x$$

$$M_b(x) = (w_0/2)[(L/2)^2 - x^2]$$

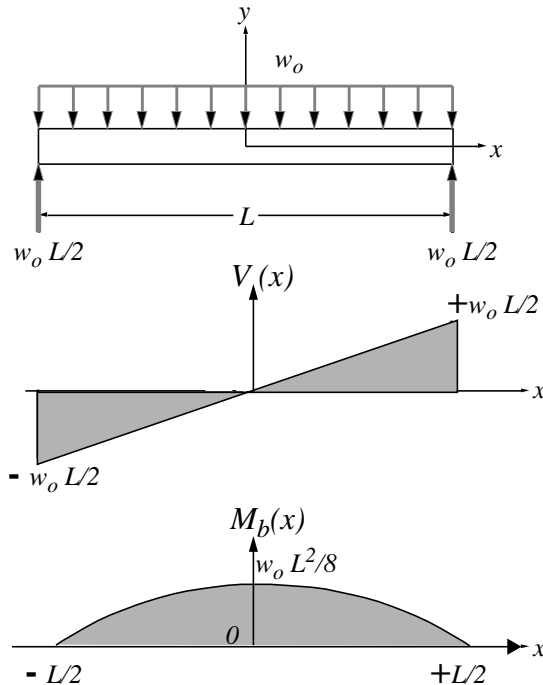

Observe:

- How by taking moments about the point x , the shear force does not appear in the moment equilibrium equation. The two equations are *uncoupled*, we can solve for $M_b(x)$ without knowing V .
- These results are the same as obtained from our solution of the differential equations. They do not immediately appear to be identical because the "x" is measured from a different position. If you make an appropriate change of coordinate, the identity will be confirmed.
- Another way to verify their consistency is to see if the differential relationships, which apply locally at any position x , are satisfied by our more recent results. Indeed they are: The **slope** of the shear force distribution is equal to the distributed load w_0 at any point x . The **slope** of the bending moment distribution is equal to the negative of the shear force $V(x)$.
- The bending moment is zero at both ends of the span. This confirms our reading of circles as frictionless pins, unable to transmit a couple.
- The bending moment is a maximum at mid-span. Its value is $M_b = w_0 L^2/8$. Note that the shear force is zero at mid-span, again in accord with our differential relationship¹
- Last, but not least, the units check. For example, a bending moment has the dimensions FL , force times length; the distributed load has dimensions F/L , force per unit length; the product of w_0 and L^2 then has the dimensions of a bending moment as we have obtained.

For another look at the use of the differential relationships as aids to constructing shear force and bending moment distributions we consider a second exercise:

Exercise 3.9

Construct shear force and bending moment diagrams for the simply-supported beam shown below. How do your diagrams change as the distance a approaches zero while, at the same time, the *resultant* of the distributed load, $w_0(x)$ remains finite and equal to P ?

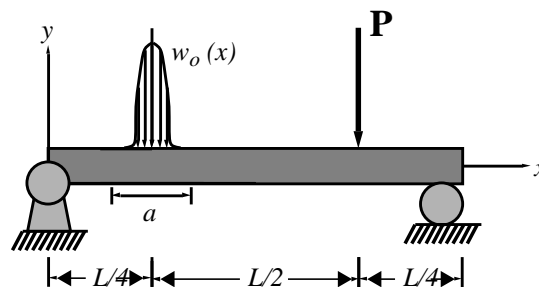

1. One must be very careful in seeking maximum bending moments by setting the shear to zero. One of the disastrous consequences of studying the differential calculus is that one might think the locus of a maximum value of a function is always found by equating the slope of the function to zero. Although true in this problem, this is not always the case. If the function is discontinuous or if the maximum occurs at a boundary then the slope need not vanish yet the function may have its maximum value there. Both of these conditions are often encountered in the study of shear force and bending moment distributions within beams.

We start with the limiting case of a *concentrated load* acting at the point to the left of center span. Two isolations of portions of the beam to the left are made at some arbitrary x – first with x less than $L/4$, (middle figure), then in the region $L/4 < x < 3L/4$, (bottom figure)– are shown.

Symmetry again requires that the vertical reactions are equal and of magnitude P . Note this remains true when we consider the distributed load $w_0(x)$ centered at $x = L/4$ as long as its resultant is equivalent to the concentrated load P .

Force and moment equilibrium for $0 < x < L/4$ yields

$$V(x) = -P$$

and

$$M_b(x) = P \cdot x$$

while for $L/4 < x < 3L/4$ we have

$$V(x) = P - P = 0$$

and

$$M_b(x) = P \cdot x - P \cdot (x - L/4) = P \cdot L/4$$

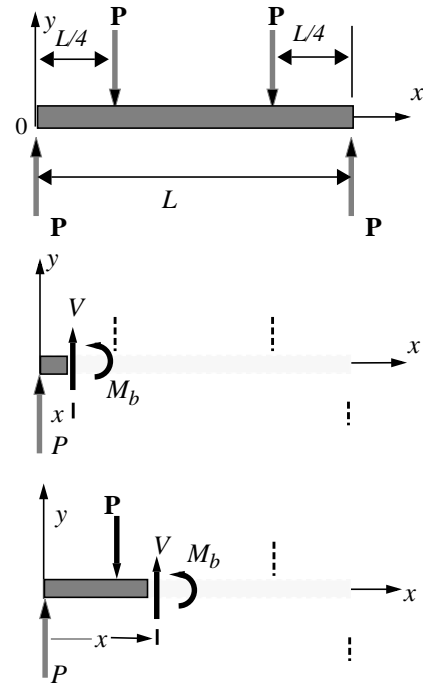

Now for the $x > 3L/4$ we could proceed by making a third isolation, setting $x > 3L/4$ but rather than pursue that tack, we step back and construct the behavior of the shear force and bending moment in this region using less machine-like, but just as rigorous language, knowing the behavior at the end points and the differential relations among shear force, bending moment, and distributed load.

The distributed load is zero for $x > 3L/4$. Hence the shear force must be a constant. But what constant value? We know that the reaction at the right end of the beam is P acting upward. Imagining an isolation of a small segment of the beam at $x \approx L$, you see that the shear force must equal a positive P . I show the convention icon at the right to help you imagine the a true isolation at $x=L$.



In the region, $3L/4 < x < L$ we have, then

$$V(x) = P$$

For the bending moment in this region we can claim that if the shear force is constant, then the bending moment must be a linear function of x with a slope equal to $-V$, i.e., $= -P$. The bending moment must then have the form

$$M(x) = -P \cdot x + C$$

where C is a constant. But the bending moment at the right end is zero. From this we can evaluate C , conclude that the bending moment is a straight line, zero at $x=L$ and with slope equal to $-P$, i.e., it has the form:

$$M_b(x) = P \cdot (L - x)$$

The shear force and bending moment diagrams are shown at the right.

I have also indicated the effect of distributing the load P out over a finite segment, a of the span, centered at $x=L/4$. Since the distributed P is equivalent to a $w(x)$, acting downward as positive, then the slope of the shear V must be positive according to our differential relationship relating the two. The bending moment too changes, is *smoothed* as a result, its slope, which is equal to $-V$, is less for $x < L/4$ and greater than it was for $x > L/4$.

We see that the effect of distributing a concentrated load is to eliminate the discontinuity, the jump, in the shear force at the point where the concentrated load is applied. We also see that the discontinuity in the **slope** of the bending moment distribution at that point dissolves. Now while at first encounter, dealing with functions that jump around can be disconcerting, reminiscent of all of that talk in a mathematics class about limits and their existence, we will welcome them into our vocabulary. For although we know that concentrated loads are as rare as frictionless pins, like frictionless pins, they are extremely useful abstractions in engineering practice. You will learn to appreciate these rare birds; imagine what your life would be like if you had to check out the effect of friction at every joint in a truss or the effect of deviation from concentration of every concentrated load P ?

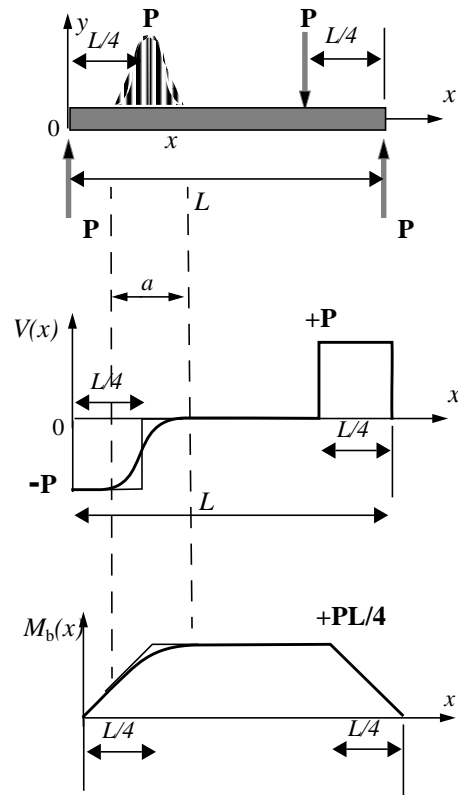

One final exercise on shear force and bending moment in a beam:

Exercise 3.10

Estimate the magnitude of the maximum bending moment due to the uniform loading of the cantilever beam which is also supported at its end away from the wall.

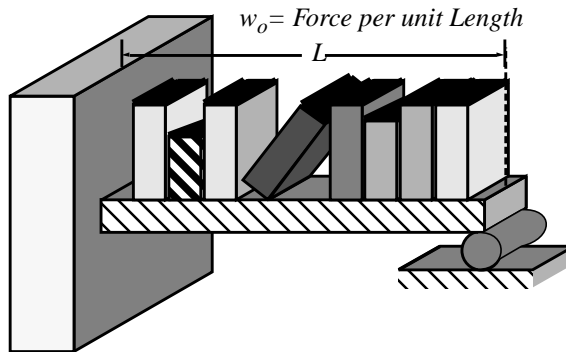

We first determine, or try to determine, the reactions at the wall and at the roller support at the right end.

Force and moment equilibrium yield,

$$R_0 - w_0 L + R_L = 0$$

and

$$-M_0 - w_0(L^2/2) + R_L \cdot L = 0$$

Here moments have been taken about left end, positive counterclockwise. Also, I have replaced the uniformly distributed load, w_0 with a statically equivalent load equal to its resultant and acting at midspan.

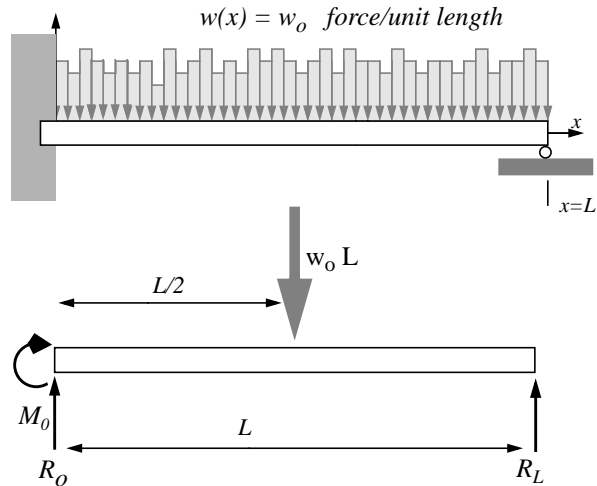

Now these are two equations but there are three unknown reactions, R_0 , R_L , M_0 . The problem is *indeterminate*, the structure is *redundant*; we could remove the support at the right end and the shelf would still work to hold up the books, assuming we do not overload the, now cantilevered, structure. But with the support at the right in place, life is hard, or at least more complex.

But wait; all that was asked was an *estimate* of the maximum bending moment. Let us press on; we are not without resources. In fact, our redundant structure looks something like the previous exercise involving a uniformly loaded beam which was simply supported at **both** ends. There we found a maximum bending moment of $w_0 L^2/8$ which acted at mid span. There! There is an estimate!¹ Can we do better? Possibly. (See Problem 3.3)

We leave beam bending for now. We have made considerable progress although we have many loose ends scattered about.

- What is the nature of the stress distribution engendered by a bending moment?
- How can we do better analyzing indeterminate structures like the one above?

We will return to answer these questions and pick up the loose ends, in Chapter 8. For now we turn to two quite different structural elements – circular shafts in torsion, and thin cylinders under internal or external pressure – to see how far we can go with equilibrium alone in our search for criteria to judge, diagnose and design structures with integrity.

1. This is equivalent to setting the resistance to rotation at the wall, on the left, to zero.

3.3 Torque, Torsion of shafts

Exercise 3.11

Estimate the torque in the shaft *RH* appearing in the figure below

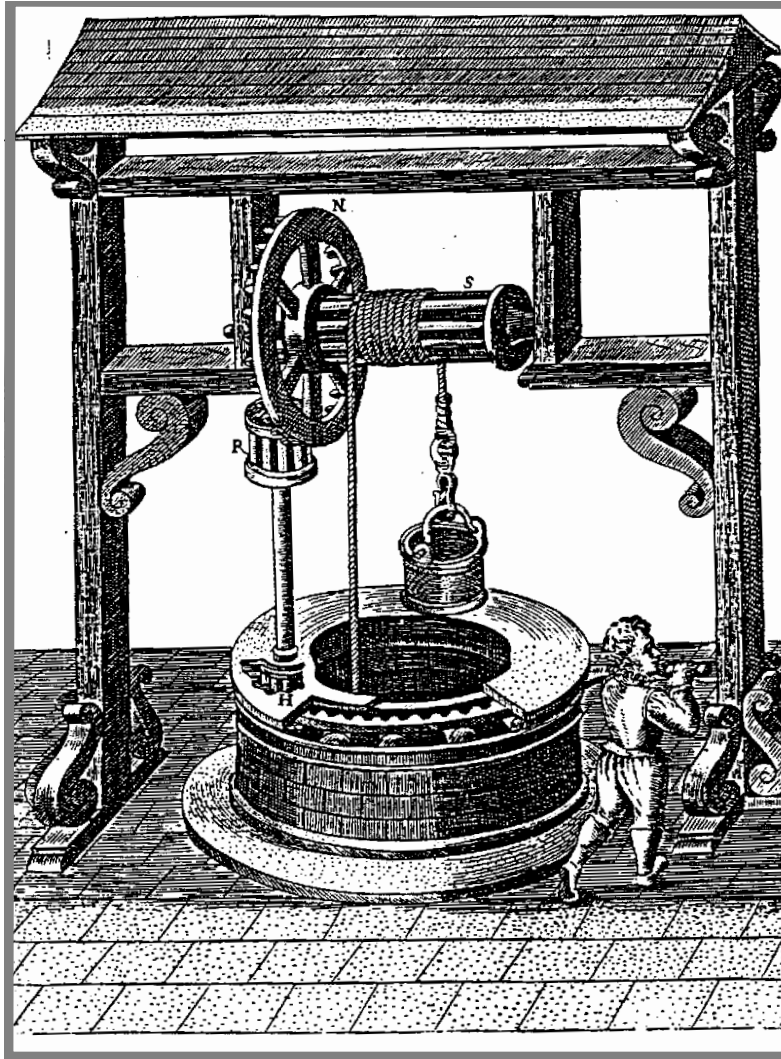

This figure, of a human-powered pump, is taken from *THE VARIOUS AND INGENIOUS MACHINES OF AGOSTINO RAMELLI*, a sixteenth century, late Renaissance work originally published in Italian and French.

We isolate pieces of the structure in turn, starting with the drum S upon its shaft at the top of the machine, then proceed to the vertical shaft RH to estimate the torque it bears. We assume in all of our fabrications that the bearings are frictionless, they can support no torque, they provide little resistance to rotation.¹

We show the reactions at the two bearings as R_A and R_B . Their values are not of interest; we need only determine the force acting on the teeth of the wheel N , labeled F_{tooth} , in order to reach our goal. Moment equilibrium about the axis of the shaft yields

$$F_{tooth} = W \cdot (r_x / r_n)$$

where W is the weight of the water bucket, assumed full of water, r_s is the radius of the drum S , and r_N the radius of the wheel N out to where the internal force acting between the teeth of wheel N and the “rundles” of the “lantern gear” R .

We now isolate the vertical shaft, rather a top section of the vertical shaft, to expose the internal torque, which we shall label M_T . On this we show the equal and opposite reaction to the tooth force acting on the wheel N , using the same symbol F_{tooth} . We let r_R be the radius of the lantern gear. We leave for an end-of-chapter exercise the problem of determining the reaction force at the bearing (not labeled) and another at the bottom of the shaft.

Moment equilibrium about the axis of the shaft yields

$$M_T = F_{tooth} \cdot r_R$$

or, with our expression for F_{tooth}

$$M_T = W(r_R \cdot r_s / r_N)$$

Now for some numbers. I take 60 *pounds* as an estimate of the weight W . I take sixty pounds because I know that a cubic foot of water weighs 62.4 *pounds* and the volume of the bucket looks to be about a cubic foot. I estimate the radius of the drum to be $r_s = 1 \text{ ft}$, that of the wheel to be three times bigger, $r_N = 3 \text{ ft}$, and finally the radius of the lantern gear to be $r_R = 1 \text{ ft}$. Putting this all together produces an estimate of the torque in the shaft of

$$M_T \approx 20 \text{ ft}\cdot\text{lb}$$

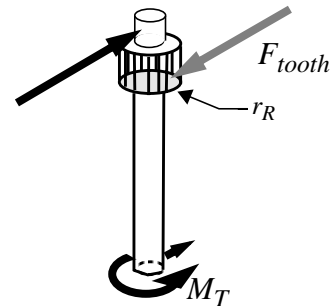
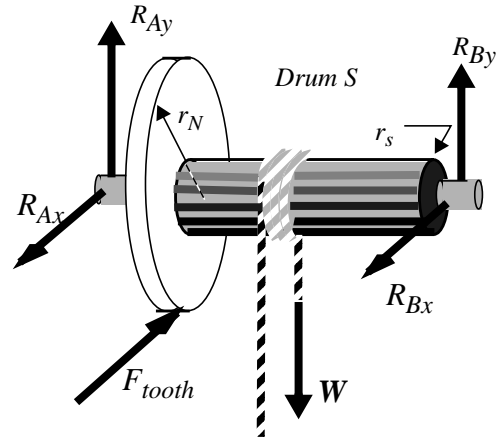

1. This is an adventurous assumption to make for the sixteenth century but, in the spirit of the Renaissance and Neo-platonic times, we will go ahead in this fashion. The drawings that are found in Ramelli's book are an adventure in themselves. Page after page of machinery for milling grain, cranes for lifting, machines for dragging heavy objects without ruining your back, cofferdams, fountains and bird calls, military screwjacks and hurling engines, as well as one hundred and ten plates of water-raising devices like the one shown here can be read as a celebration of the rebirth of Western thought, and that rebirth, as we see here extended to encompass technology. This, in some ways excessive display of technique – many of the machines are impractical, drawn only to show off – has its parallel in contemporary, professional engineering activity within the academies and universities. Witness the excessive production of scholarly articles in the engineering sciences whose titles read like one hundred and ten permutations on a single fundamental problem.

If Ramelli were to ask, like Galileo, when the shaft *HR* might fail, he would be hard pressed to respond. The reason? Assuming that failure of the shaft is a local, or microscopic, phenomenon, he would need to know how the torque M_T estimated above is distributed over a cross section of the shaft. The alternative would be to test every shaft of a different diameter to determine the torque at which it would fail.¹

We too, will not be able to respond at this point. Again we see that the problem of determining the stresses engendered by the torque, more specifically, the shear stress distribution over a cross section of the shaft, is *indeterminate*. Still, as we did with the beam subject to bending, let us see how far we can go.

We need, first, to introduce the notion of *shear stress*. Up to this point we have toyed with what is called a *normal stress*, *normal* in the sense that it acts *perpendicular* to a surface, e.g., the tensile or compressive stress in a truss member. A *shear stress* acts *parallel* to a surface.

The figure at the right shows a thin-walled tube loaded in torsion by a torque (or moment) M_T . The bit cut out of the top of the tube is meant to show a *shear stress* τ , distributed over the thickness and acting perpendicular to the radius of the tube. It acts parallel to the surface; we say it tends to shear that surface over the one below it; the cross section rotates a bit about the axis relative to the cross sections below.

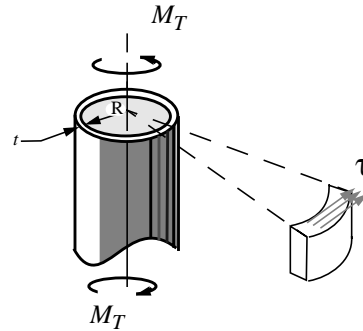

I claim that if the tube is *rotationally symmetric*, that is, its geometry and properties do not change as you move around the axis of the tube, then each bit of surface will look the same as that shown in the figure. Furthermore, if we assume that the shear is uniformly distributed over the thickness of the tube we can figure out how big the shear stress is in terms of the applied torque and the geometry of the tube.²

The contribution to the torque of an angular segment of arc length $R\Delta\theta$ will be

$\tau \cdot R\Delta\theta \cdot t$: the element of force
times the radius

$\tau \cdot R^2\Delta\theta \cdot t$: the element of torque

so integrating around the surface of the tube gives a resultant

$$2\pi R^2 t \cdot \tau \quad \text{which must equal the applied torque, hence} \quad \tau = \frac{M_T}{2\pi R^2 t}$$

Note that the dimensions of shear stress are force per unit area as they should be.

1. A torque of 20 ft-lb. is not a very big torque. The wooden shaft RH would have to be extremely defective or very slender to have a torque of this magnitude cause any problems. Failure of the shaft is unlikely. On the other hand, we might ask another sort of question at this point: What force must the worker exert to raise the bucket of water? Or, how fast must he walk round and round to deliver water at the rate of 200 gallons per hour? At this rate, how many horse power must he supply? Failure in this mode is more likely.

2. This is reminiscent of our analysis of an I beam.

Exercise 3.12

Show that an equivalent system to the torque M_T acting about an axis of a solid circular shaft is a shear stress distribution $\tau(r,\theta)$ which is independent of θ but otherwise an arbitrary function of r .

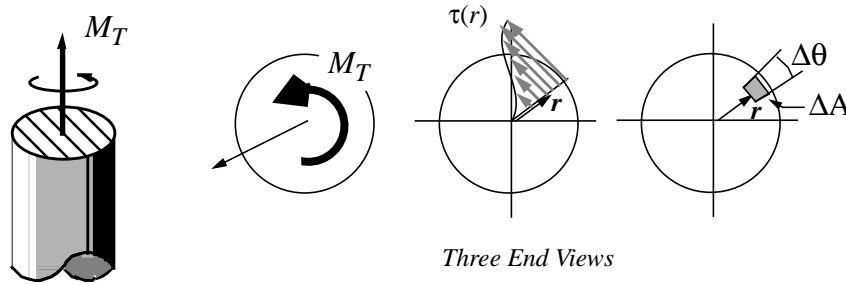

We show such an arbitrary shear stress τ , a force per unit area, varying from zero at the axis to some maximum value at the outer radius R . We call this a *monotonically increasing function* of r . It need not be so specialized a function but we will evaluate one of this kind in what follows.

We show too a differential element of area $\Delta A = (r\Delta\theta)(\Delta r)$, where polar coordinates are used. We assume rotational symmetry so the shear stress does not change as we move around the shaft *at the same radius*. Again, the stress distribution is *rotationally symmetric*, not a function of the polar coordinate θ . With this, for this distribution to be equivalent to the torque M_T , we must have, equating moments about the axis of the shaft:

$$M_T = \int_{\text{Area}} r \cdot [\tau \cdot \Delta A]$$

where the bracketed term is the differential element of force and r is the moment arm of each force element about the axis of the shaft.

Taking account of the rotational symmetry, summing with respect to θ introduces a factor of 2π and we are left with

$$M_T = 2\pi \int_{r=0}^{r=R} \tau(r) \cdot r^2 dr$$

where R is the radius of the shaft.

This then shows that we can construct one, or many, shear stress distribution(s) whose resultant moment about the axis of the cylinder will be equivalent to the torque, M_T . For example, we might take

$$\tau(r) = c \cdot r^n$$

where n is any integer, carry out the integration to obtain an expression for the constant c in terms of the applied torque, M_T . This is similar to the way we proceeded with the beam.

3.4 Thin Cylinder under Pressure

The members of a truss structures carry the load in tension or compression. A cylinder under pressure behaves similarly in that the most significant internal force is a tension or compression. And like the truss, if the cylinder is thin, the problem of determining these internal forces is statically determinate, or at least approximately so. A few judiciously chosen isolations will enable us to estimate the tensile and compressive forces within making use, as always, of the requirements for static equilibrium. If, in addition, we assume that these internal forces are uniformly distributed over an internal area, we can estimate when the thin cylindrical shell might yield or fracture, i.e., we can calculate an internal normal stress. We put off an exploration of failure until Chapter 8. We restrict our attention here to getting estimates of the internal stresses.

Consider first an isolation that cuts the thin shell with a plane perpendicular to the cylinder's axis.

We assume that the cylinder is internally pressurized. In writing equilibrium, we take the axial force distributed around the circumference, f_a , to be uniformly distributed as it must since the problem is rotationally symmetric. Note that f_a , has dimensions *force per unit length*. For equilibrium in the vertical direction:

$$2\pi R \cdot f_a = p_i \cdot \pi R^2$$

Solving for this distributed, internal force we find

$$f_a = p_i \cdot (R/2)$$

If we now assume further that this force per unit length of circumference is uniformly distributed over the thickness, t , of the cylinder, akin to the way we proceeded on the thin hollow shaft in torsion, we obtain an estimate of the tensile stress, a force per unit area of the thin cross section, namely

Observe that the stress σ_a can be very much larger than the internal pressure if the ratio of thickness to radius is small. For a thin shell of the sort used in aerospace vehicles, tank trailers, or a can of coke, this ratio may be on the order of 0.01. The stress then is on the order of 50 times the internal pressure. But this is not the maximum internal normal stress! Below is a second isolation, this time of a circumferential section.

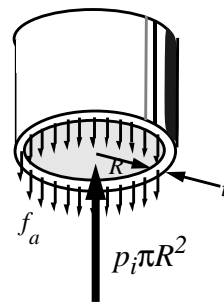

$$\sigma_a = p_i \cdot (R/2t)$$

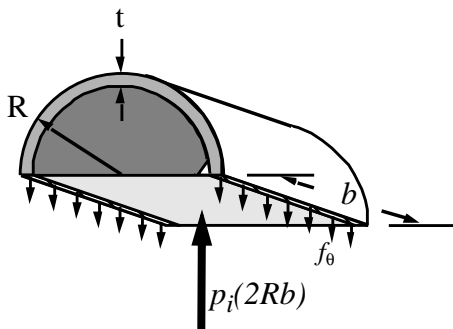

Equilibrium of this isolated body requires that

$$p_i \cdot (2Rb) = 2bf_\theta$$

where f_θ is an internal, again tensile, uniformly distributed force per unit length acting in the “theta” or *hoop* direction. Note: We do not show the pressure and the internal forces acting in the axial direction. These are self equilibrating in the sense that the tensile forces on one side balance those on the other side of the cut a distance b along the cylinder. Note also how, in writing the resultant of the internal pressure as a vertical force alone, we have put to use the results of section 2.2.

Solving, we find

$$f_{\theta} = p_i \cdot R$$

If we again assume that the force per unit length in the axial direction is also uniformly distributed over the thickness, we find for the *hoop stress*

$$\sigma_{\theta} = p_i \cdot (R/t)$$

which is twice as big as what we found for the internal stress acting internally, parallel to the shell's axis. For really thin shells, the *hoop stress* is critical.

Design Exercise 3.1

Low-end Diving Board

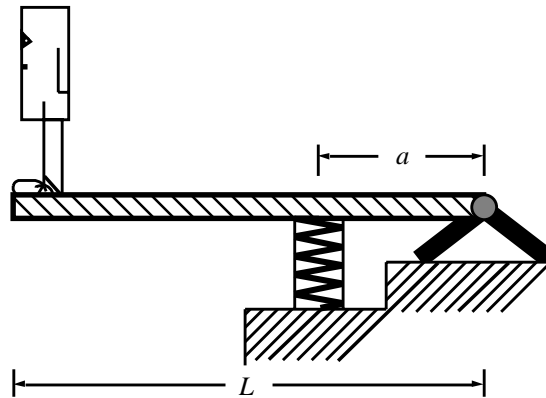

You are responsible for the design of a complete line of diving boards within a firm that markets and sells worldwide. Sketch a rudimentary design of a *generic* board. Before you start, list some performance criteria your product must satisfy. Make a list also of those elements of the diving board, taken as a whole system, that determine its performance.

Focusing on the dynamic response of the system, explore how those elements might be *sized* to give your proposed design the right *feel*. Take into account the range of sizes and masses of people that might want to make use of the board. Can you set out some criteria that must be met if the performance is to be judged good? Construct more alternative designs that would meet your main performance criteria but would do so in different ways.

Design Exercise 3.2

Low-end Shelf Bracket

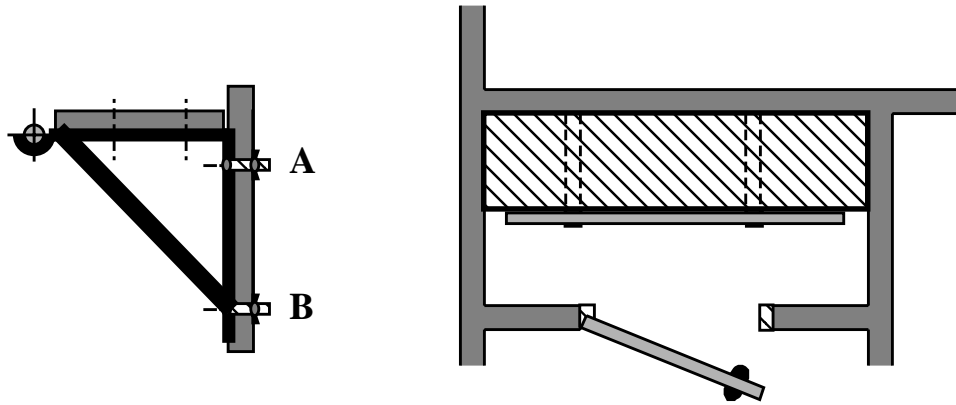

Many closets are equipped with a clothes hanger bar that is supported by two sheetmetal brackets. The brackets are supported by two fasteners *A* and *B* as shown that are somehow anchored to the wall material (1/2 inch sheetrock, for example). A shelf is then usually placed on top of the brackets. There is provision to fasten the shelf to the brackets, but this is often not done. When overloaded with clothes, long-playing records, stacks of back issues of *National Geographic Magazine*, or last year's laundry piled high on the shelf, the system often fails by pullout of the upper fastener at *A*.

- Estimate the pullout force acting at *A* as a function of the load on the clothes bar and shelf load.
- Given that the wall material is weak and the pullout strength at *A* cannot be increased, devise a design change that will avoid this kind of failure in this, a typical closet arrangement.

3.5 Problems - Internal Forces and Moments

3.1 Consider the truss structure of Exercise 3.3: *What if* you are interested only in the forces acting within the members at midspan. *Show that* you can determine the forces in members 6-8, 6-9 and 7-9 with but a **single** isolation, after you have determined the reactions at the left and right ends. This is called *the method of sections*.

3.2 *Show that* for **any** exponent n in the expression for the normal stress distribution of Exercise 3.5, the maximum bending stress is given by

$$|\sigma_{\max}| = 2(n + 2) \cdot M_0 / (bh^2)$$

If M_0 is the moment at the root of an end-loaded cantilever (end-load = W) of length L , then this may be written

$$|\sigma_{\max}| = 2(n + 2) \cdot (L/h)(W/bh)$$

hence the normal stress due to bending, for a beam with a rectangular cross section will be significantly greater than the average shear stress over the section.

3.3 *Estimate* the maximum bending moment within the tip supported, uniformly loaded cantilever of exercise 3.10 using the result for a uniformly loaded cantilever which is unsupported at the right. Would you expect this to be an *upper or lower bound* on the value obtained from a full analysis of the statically indeterminate problem?

3.4 *Construct* the shear force and bending moment diagram for Galileo's lever.

3.5 *Construct* a shear force and bending moment diagram for the truss of Exercise 3.4. Using this, estimate the forces carried by the members of the third bay out from the wall, i.e., the bay starting at node E .

3.6 *Estimate* the maximum bending moment in the wood of the clothespin shown full size. Where do you think this structure would fail?

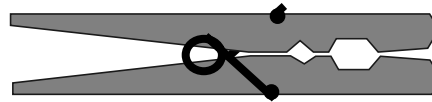

3.7 *Construct* an expression for the bending moment at the root of the lower limbs of a mature maple tree in terms of the girth, length, number of offshoots, etc... whatever you judge important. How does the bending moment vary as you go up the tree and consider smaller limbs.

3.8 A hand-held power drill of 1/4 horsepower begins to grab when its rotational speed slows to 120 rpm, that's revolutions per minute. *Estimate* the force and couple I must exert on the handle to keep a 1/4 inch drill aligned.

3.9 *Estimate* the force Ramelli's laborer (or is it Ramelli himself?) must push with in order to just lift a full bucket of water from the well shown in the figure.

3.10 Construct the shear force and bending moment distribution for the diving board shown below. Assuming the board is rigid relative to the linear spring at a , show that the equivalent stiffness of the system at L , K in the expression $P = K\Delta$ where Δ is the deflection under the load, is

$$K = k \cdot (a/L)^2$$

where k is the stiffness of the linear spring at a .

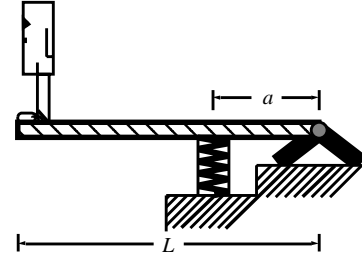

3.11 Find the force in the member CD of the structure shown in terms of P . All members, save CF are of equal length. In this, use method of joints starting from either node A (or B) or node G, according to your teacher's instructions.

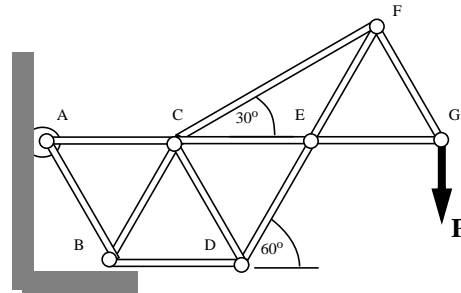

3.12 Find the reactions acting at A and B in terms of P and the dimensions shown (x_p/L).

Isolate member BC and draw a free body diagram which will enable you to determine the forces acting on this member.

Find those forces, again in terms of P and the dimensions shown.

Find the force in the horizontal member of the structure shown.

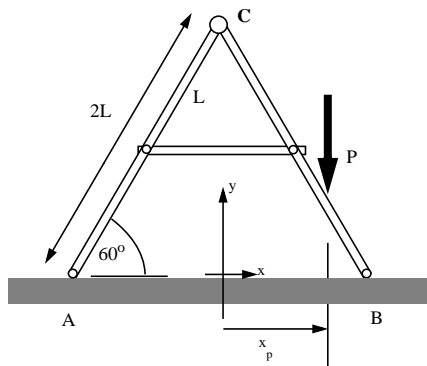

3.13 Determine the forces acting on member DE. How does this system differ from that of the previous problem? How is it the same?

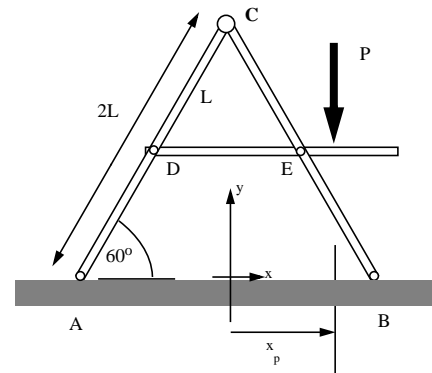

3.14 Estimate the forces acting in members EG, GF, FH in terms of P . In this, use but one free body diagram.

Note: Assume the drawing is to scale and, using a scale, introduce the relative distances you will need, in writing out the requirement of moment equilibrium, onto your free body diagram.

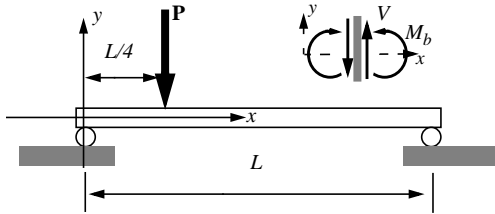
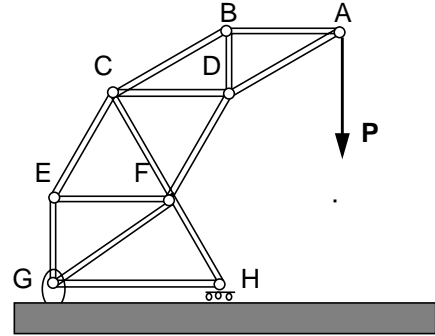

3.15 A simply supported beam of length L carries a concentrated load, P , at the point shown.

- i) Determine the reactions at the supports.
- ii) Draw two free body diagrams, isolating a portion of the beam to the right of the load, another to the left of the load.
- iii) Apply force equilibrium and find the shear force V as a function of x over both domains Plot $V(x)$
- iv) Apply moment equilibrium and find how the bending moment M_b varies with x . Plot $M_b(x)$.
- v) Verify that $dM_b/dx = -V$.

3.16A simply supported beam (indicated by the rollers at the ends) carries a trolley used to lift and transport heavy weights around within the shop. The trolley is motor powered and can move between the ends of the beam. For some arbitrary location of the trolley along the beam, a ,

- i) What are the reactions at the ends of the beam?
- ii) Sketch the shear force and bending moment distributions.

iii) How does the *maximum* bending moment vary with a ; i.e., change as the trolley moves from one end to the other?

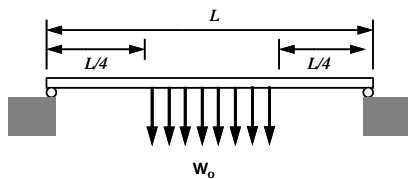
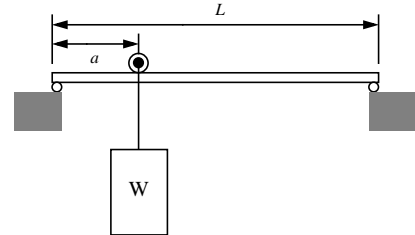

3.17 Sketch the shear force and bending moment distribution for the beam shown at the left. Where does the maximum bending moment occur and what is its magnitude.

3.18A simply supported beam of length L carries a uniform load per unit length, w_0 , over a portion of the length, $\beta L < x < L$

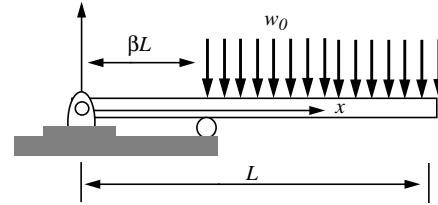

- i) Determine the reactions at the supports.
- ii) Draw two free body diagrams, isolating portions of the beam to the right of the origin. Note: include all relevant dimensions as well as known and unknown force and moment components.
- iii) Apply force equilibrium and find the shear force V as a function of x . Plot.
- iv) Apply moment equilibrium and find how the bending moment M_b varies with x . Plot.
- v) Verify that $dM_b/dx = -V$ within each region.

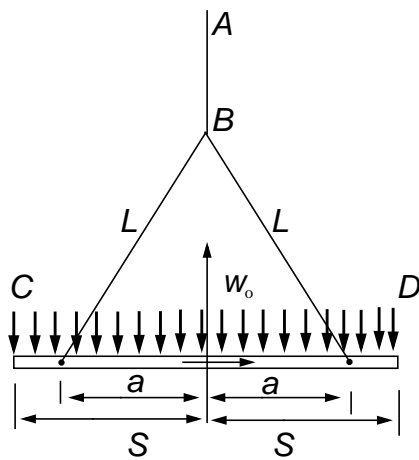

3.19 A beam, carrying a uniformly distributed load, is suspended by cables from the end of a crane (crane not shown). The cables are attached to the beam at a distance a from the center line as shown. Given that

$$a = (3/4)S \text{ and } L = (3/2)S$$

- i) Determine the tension in the cable AB . Express in non-dimensional form, i.e., with respect to $w_0 S$.
- ii) Determine the tension in the cables of length L .
- iii) Sketch the beam's shear force and bending moment diagram. Again, non-dimensionalize. What is the magnitude of the maximum bending moment and where does it occur?
- iv) Where should the cables be attached - ($a/S = ?$) - to minimize the magnitude of the maximum bending moment? What is this minimum value?
- v) If a/S is chosen to minimize the magnitude of the maximum bending moment, what then is the tension in the cables of length L ? Compare with your answer to (ii).

3.20 A cantilever beam with a hook at the end supports a load P as shown..

The bending moment at $x = 3/4 L$ is:

- a) positive and equal to $P*(L/4)$
- b) negative and equal to $P*(3L/4)$
- c) zero.

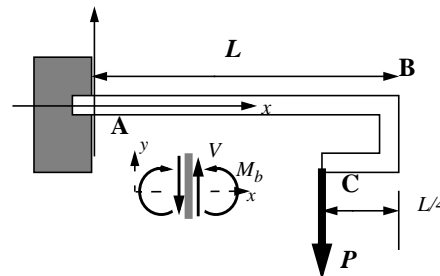

3.21 For the truss shown below,

- i) Isolate the full truss structure and replace the applied loads with an equivalent load (no moment) acting at some distance, b , from the left end. What is b ?
- ii) Determine the reactions at f and l .
- iii) Find the force in member ch with but a single additional free body diagram.

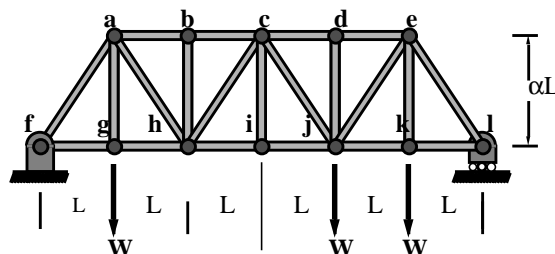

3.22 Find an expression for the internal moment and force acting at x , some arbitrary distance from the root of the cantilever beam. Neglect the weight of the beam.

What if you now include the weight of the beam, say w_0 per unit length; how do these expressions change?

What criteria would you use in order to safely neglect the weight of the beam?

