

8.1 The Moment/Curvature Relation

Just as we took the *pure bending* construction to be accurate enough to produce useful estimates of the normal stress due to bending for loadings that were not of this type, so too we will use the same *moment/curvature* relationship to produce a differential equation for the transverse displacement, $v(x)$ of the beam at every point along the neutral axis.

$$\frac{M_b}{EI} = \frac{d\phi}{ds}$$

The moment/curvature relationship itself is this differential equation. All we need do is express the curvature of the deformed neutral axis in terms of the transverse displacement. This is a straight forward application of the classical calculus as you have seen perhaps but may also have forgotten. That's ok. For it indeed can be shown that¹:

$$\frac{d\phi}{ds} = \frac{\frac{d^2 v}{dx^2}}{\left[1 + \left(\frac{dv}{dx}\right)^2\right]^{\frac{3}{2}}}$$

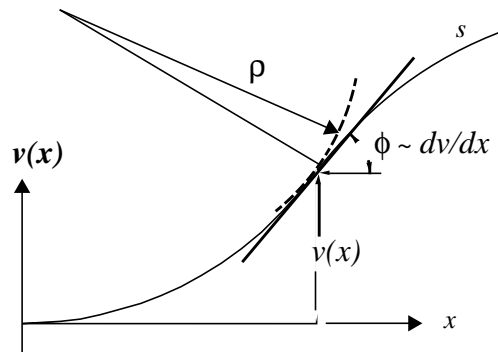

There now we have it – once given the bending moment as a function of x all we need do is solve this non-linear, second order, ordinary differential equation for the transverse displacement $v(x)$. Hold on.

1. Note in this exact relationship, the independent variable is s , the distance along the curved, deformed neutral, x axis.

When is the last time you solved a second order, **non linear** differential equation? Leonhard Euler attacked and resolved this one for some quite sophisticated end-loading conditions back in the eighteenth century but we can get away more cheaply by making our usual assumption of small displacement and rotations.

That is we take $\left(\frac{dv}{dx}\right)^2 < 1$ which says that the slope of the deflection is small with respect to 1.0. Or equivalently that the rotation of the cross section as measured by $\phi \approx (dv/dx)$ is less than 1.0, one radian. In this we note the dimensionless character of the slope. Our moment curvature equation can then be written more simply as

$$\frac{d^2 v}{dx^2} = \frac{M_b(x)}{EI}$$

Exercise 8.1 – Show that, for the end loaded beam, of length L , simply supported at the left end and at a point $L/4$ out from there, the tip deflection under the load P is given by

$$\Delta = (3/16) \cdot \frac{PL^3}{EI}$$

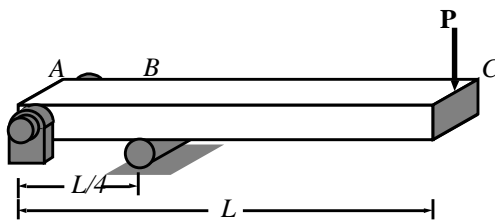

The first thing we must do is determine the bending moment distribution as a function of x . No problem. The system is statically determinate. We first determine the reactions at A and B from an isolation of the whole. We find $R_A = 3P$, directed down, and $R_B = 4P$ directed up.

An isolation of a portion to the right of the support at B looks very much like Galileo's cantilever. In this region we find a constant shear force equal in magnitude to the end load and a linearly varying bending moment which, at $x=L/4$ is equal to $-(3/4)PL$.

We note that the shear between $x=0$ and $x < L/4$ equals R_A , the reaction at the left end, and that the bending moment must return to zero. The discontinuity in the shear force at B allows the discontinuity in slope of M_b at that point.

Our *linear, ordinary, second order* differential equation for the deflection of the neutral axis becomes, **for $x < L/4$**

$$\frac{d^2 v}{dx^2} = \frac{M_b(x)}{EI} = -\frac{3P}{EI} \cdot x$$

Integrating this is straight forward. I must be careful, though, not to neglect to introduce a constant of integration. I obtain

$$\frac{dv}{dx} = -\frac{3P}{EI} \cdot (x^2/2) + C_1$$

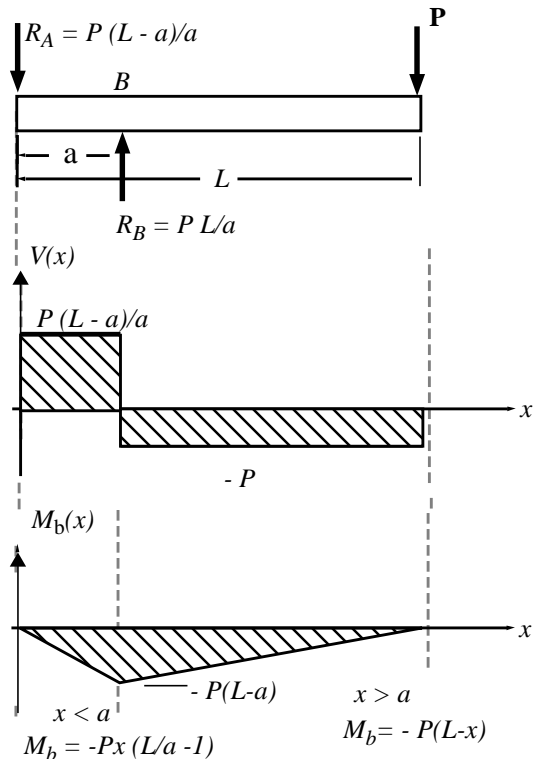

This is the slope of the deflected neutral axis as a function of x , at least within the domain $0 < x < L/4$. Integrating once more produces an expression for the displacement of the neutral axis and, again, a constant of integration.

$$v(x) = -\frac{3P}{EI} \cdot (x^3/6) + C_1 \cdot x + C_2$$

Here then is an expression for the deflected shape of the beam in the domain left of the support at B . But what are the constants of integration? We determine the constants of integration by evaluating our expression for displacement $v(x)$ and/or our expression for the slope dv/dx at points where we are sure of their values. One such *boundary condition* is that, at $x=0$ the displacement is zero, i.e., $v(x)|_{x=0} = 0$

Another is that, at the support point B , the displacement must vanish, i.e., $v(x)|_{x=L/4} = 0$
 These yield $C_2 = 0$ and $C_1 = \frac{PL^2}{(32EI)}$ and we can write, for $x < L/4$

$$v(x) = -\frac{P}{2EI} \cdot (x^3 - x/16)$$

So far so good. We have pinned down the displacement field for the region left of the support point at B . Now for the domain $L/4 < x < L$.

The *linear, ordinary, second order* differential equation for the deflection, again obtained from the moment/curvature relation for small deflections and rotations, becomes

$$\frac{d^2 v}{dx^2} = -\frac{P}{EI} \cdot (L-x)$$

Integrating this twice we obtain, first an expression for the slope, then another for the displacement of the neutral axis. To wit:

$$\frac{dv}{dx} = -\frac{P}{EI} \cdot (Lx - x^2/2) + D_1$$

and

$$v(x) = -\frac{P}{EI} \cdot [Lx^2/2 - x^3/6] + D_1 \cdot x + D_2$$

Now for some boundary conditions: It appears at first look that we have but one condition, namely, at the support point B , the displacement must vanish. Yet we have two constants of integration to evaluate!

The key to resolving our predicament is revealed by the form of the equation for the slope; we need to fix the slope at some point in order to evaluate D_1 . We do this by insisting that the slope of the beam is continuous as we pass over the support point B . That is, the two slopes, that of $v(x)$ evaluated at the left of B must equal that of $v(x)$ evaluated just to the right of B . Our boundary conditions are then, for $x > L/4$:

$$v(x)|_{x=L/4} = 0$$

and

$$\left(\frac{dv}{dx}\right)_{x=L/4} = -\frac{PL^2}{16EI}$$

where the right hand side of this last equation has been obtained by evaluating the slope to the left of B at that support point. Sparing you the details, which you are encouraged to plough through at your leisure, I, and I hope you, obtain

$$D_1 = (5/32) \cdot \frac{PL^2}{EI} \quad \text{and} \quad D_2 = -(1/96) \cdot \frac{PL^3}{EI}$$

So, for $L/4 < x < L$ we can write:

$$v(x) = -\left(\frac{PL^3}{96EI}\right) \cdot [1 - 15(x/L) + 48(x/L)^2 - 16(x/L)^3]$$

and the tip deflection is

$$v(L) = -(3/16) \cdot \frac{PL^3}{EI}$$

where the negative sign indicates that the tip deflects downward with the load directed downward as shown.

The process and the results obtained above provoke the following observations:

- The results are dimensionally correct. The factor $PL^3/(EI)$ has the dimensions of length, that is $FL^3/[(F/L^2)L^4] = L$.
- We can speak of an *equivalent stiffness* under the load and write

$$P = K\Delta \quad \text{where} \quad K = (16/3) \cdot \frac{EI}{L^3}$$

For example, an aluminum bar with a circular cross section of radius 1.0in , and length 3.0ft . would have, with $I = \pi r^4/4 = 0.785\text{ in}^4$, and $E = 10 \times 10^6\text{ psi}$, an *equivalent stiffness of* $K=898\text{ lb/inch}$. If it were but one foot in length, this value would be increased by a factor of nine. Note in this the sensitivity of stiffness to length. We say “it goes as the inverse of the length cubed”. But then, the stiffness is even more sensitive to the radius of the shaft: “it goes as the radius to the fourth power”. Finally note that changing materials from aluminum to steel will increase the stiffness by a factor of three.

- The process was lengthy. One has to carefully establish an appropriate set of boundary conditions and be meticulous in algebraic manipulations¹. It’s not the differential equation that makes finding the displacement function so tedious; it’s, as you can see, the discontinuity in the loading, reflected in the necessity of writing out a different expression for the bending moment over different domains, and the matching of solutions at the boundaries of these regions that makes life difficult.

Fortunately, others have labored for a century or two cranking out solutions to this quite ordinary differential equation. There are reference books that provide full coverage of these and other useful formulae for beam deflections and many other things. One of the classical works in this regard is Roark and Young, *FORMULAS FOR STRESS AND STRAIN*, 5th Edition, McGraw-Hill, 1975. We summarize selected results as follow.

1. It took me three passes through the problem to get it right.

End-loaded Cantilever

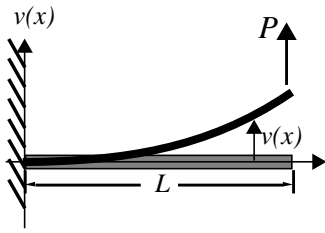

For $0 < x < L$ $v(x) = [PL^3/(6EI)][3(x/L)^2 - (x/L)^3]$

$v|_{max} = PL^3/(3EI)$ at $x=L$

Couple, End-loaded Cantilever

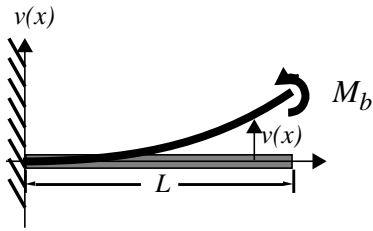

For $0 < x < L$ $v(x) = [ML^2/(2EI)] (x/L)^2$

$v|_{max} = ML^2/(2EI)$ at $x=L$

Uniformly Loaded Cantilever

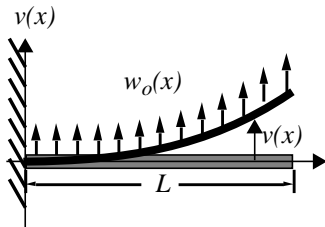

For $0 < x < L$

$v(x) = [w_o L^4/(24EI)] (x/L)^2 [(x/L)^2 - 4(x/L) + 6]$

$v|_{max} = w_o L^4/(8EI)$ at $x=L$

Uniformly Loaded Simply-Supported Beam

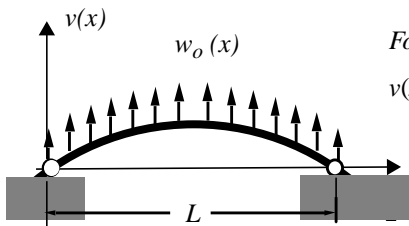

For $0 < x < L$

$v(x) = [w_o L^4/(24EI)] (x/L) [1 - 2(x/L)^2 + (x/L)^3]$

$v|_{max} = [5w_o L^4/(384EI)]$ at $x=L/2$

Couple, End-loaded Simply-Supported Beam

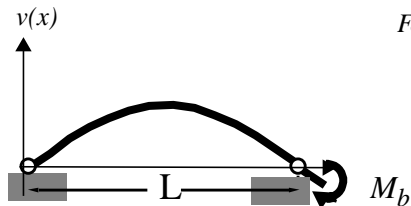

For $0 < x < L$

$v(x) = - [ML^2/(6EI)] (x/L) [1 - x^2/L^2]$

$v|_{max} = [ML^2/(9\sqrt{3} EI)]$ at $x=L/\sqrt{3}$

Point Load, Simply-Supported Beam

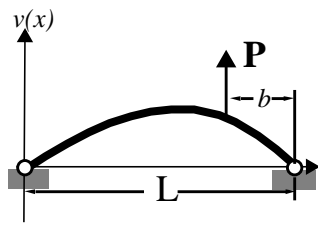

For $0 < x < (L-b)$

$$v(x) = [PL^3/(6EI)] (b/L) [-(x/L)^3 + (1-b^2/L^2)(x/L)]$$

$$v|_{max} = PL^3/[9\sqrt{3} EI] (b/L)[1- b^2/L^2]^{3/2} \text{ at } x=(L/3)\sqrt{(1-b^2/L^2)}$$

For $(L-b) < x < L$

$$v(x) = [PL^3/(6EI)] (b/L) \{ (L/b) [(x/L) - (1-b/L)]^3 - (x/L)^3 + (1-b^2/L^2)(x/L) \}$$

With these few relationships we can construct the deflected shapes of beams subjected to more complex loadings and different boundary conditions. We do this by *superimposing* the solutions to more simple loading cases, as represented, for example by the cases cited above.

Exercise 8.2—Show that the expression obtained for the tip deflection as a function of end load in the previous exercise can be obtained by *superimposing* the displacement fields of two of the cases presented above.

We will consider the beam deflection at the tip to be the sum of two parts: One part will be the deflection due to the beam acting as if it were cantilevered to a wall at the support point B, the middle figure below, and a second part due to the rotation of the beam at this imagined *root* of the cantilever at B—the figure left below.

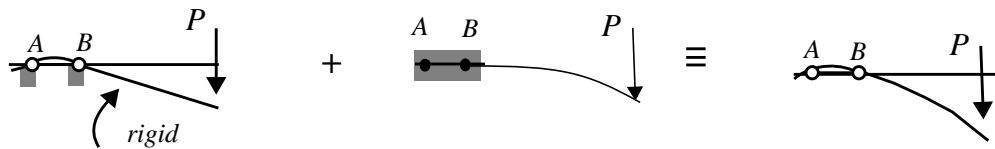

We first determine the rotation of the beam at this point, at the support B. To do this we must imagine the effect of the load P applied at the tip upon the deflected shape back within the region $0 < x < L/4$. This effect can be represented as an equivalent force system at B acting internally to the beam. That is, we cut away the portion of the beam $x > L/4$ and show an equivalent vertical force acting downward of magnitude P and a clockwise couple of magnitude $P(3L/4)$ acting at B.

Now the force P produces no deflection. The couple M produces a rotation which we will find by evaluating the slope of the displacement distribution for a couple, end-loaded, simply supported beam. From above we have, letting lower case l stand in for the span from A to B,

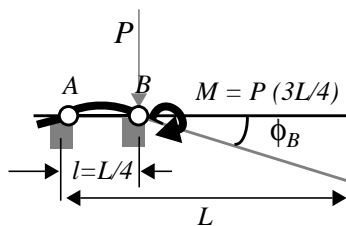

$$v(x) = -[Ml^2/(6EI)] (x/l) [1 - x^2/l^2]$$

$$\text{so } dv/dx = - [Ml/(6EI)] (1 - 3x^2/l^2)$$

This yields, for the slope, or rotation at the support point B, $dv/dx|_B = - Ml/(3EI)$. The couple is $M = 3PL/4$ so the rotation at B is

$$\phi_B = - \frac{PL^2}{16EI}$$

The deflection at the tip of the beam where the load P is applied due to this rotation is, for small rotations, approximated by

$$\Delta_{\text{rigid body}} = (3/4) \cdot L\phi_B = -\frac{3PL^3}{64EI}$$

where the negative sign indicates that the tip displacement due to this effect is downward.¹

We now superimpose upon this displacement field, the displacement of a beam of length $3L/4$, imagined cantilevered at B , that is a displacement field whose slope is zero at B . We have, for the end loaded cantilever, that the tip displacement relative to the root is $-Pl^3/(3EI)$ where now the lower case “l” stands in for the length $3L/4$ and we have noted that the load acts downward. With this, the tip deflection due to this cantilever displacement field is

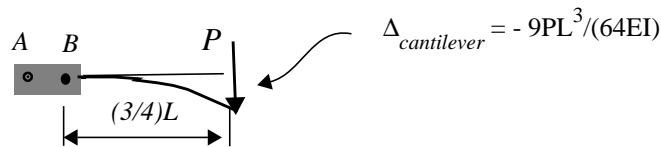

So the final result, the total deflection at the tip is, as before, $\Delta = -3PL^3/(16EI)$.

Exercise 8.3 - Estimate the magnitude of the maximum bending moment due to the uniform loading of the cantilever beam which is also supported at its end away from the wall.

Deja vu! We posed this challenge back in an earlier chapter. There we made an estimate based upon the maximum bending moment within a uniformly loaded **simply supported** beam. We took $w_0 L^2/8$ as our estimate. We can do better now.

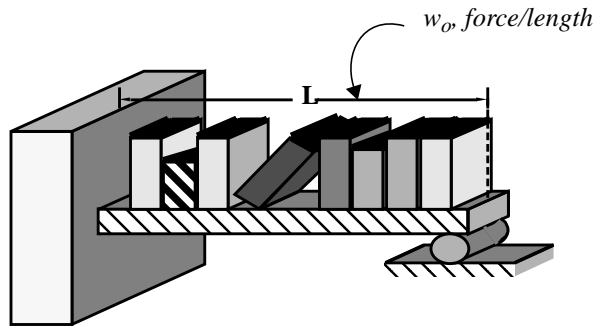

We use superpositioning. We will consider the tip deflection of a uniformly loaded cantilever. We will consider the tip deflection of an end

loaded cantilever where the end load is just the reaction force (the unknown reaction force because the problem is statically indeterminate) at the end. We then sum the two and figure out what the unknown reaction force must be in order for the sum to be zero. This will be relatively quick and painless, to wit:

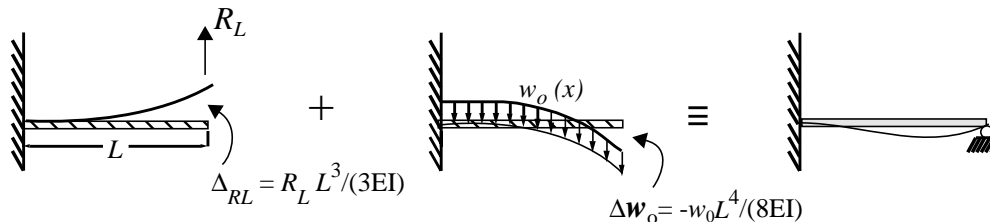

1. In this problem M is taken positive in opposition to our usual convention for bending moment. I have left off the subscript b to avoid confusion.

For the end-loaded cantilever we obtain $\Delta_{RL} = R_L L^3/(3EI)$ where the deflection is positive up. For the uniformly loaded cantilever we have $\Delta w_o = -w_o L^4/(8EI)$. The two sum to zero if and only if $R_L = (3/8) \cdot w_o \cdot L$

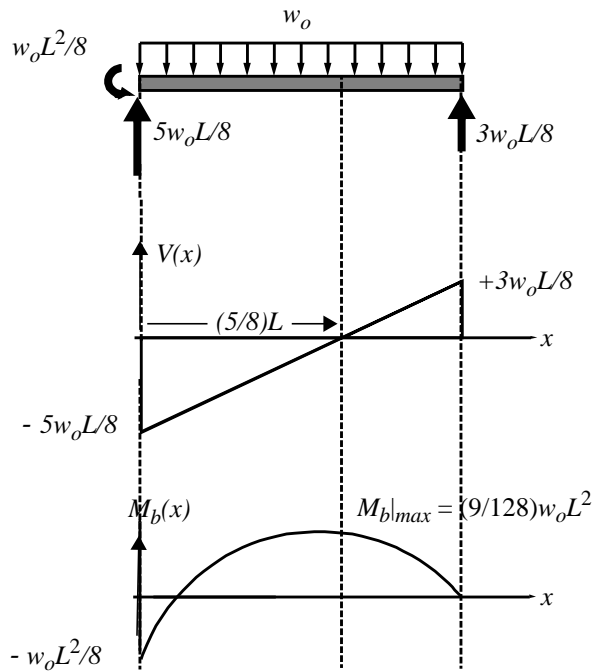

We have resolved a statically indeterminate problem through the consideration of displacements and insisting on a deformation pattern compatible with the constraint at the end – that the displacement there be zero. With this, we can determine the reactions at the root and sketch the shear force and bending moment distribution. The results are shown below.

We see that there are two positions where the bending moment must be inspected to determine whether it attains a maximum. At the root we have $|M_b| = (1/8)w_o L^2$ while at $x=(5/8)L$ its magnitude is $(9/128)w_o L^2$. The moment thus has maximum magnitude at the root. It is there where the stresses due to bending will be maximum, there where failure is most likely to occur¹.

1. If we compare this result with our previous estimate made back in exercise 3.9, we find the latter was the same magnitude! But this is by chance; In the simply supported beam the maximum moment occurs at mid-span. Here it occurs at the left end.

8.2 Buckling of Beams

Buckling of beams is an example of a failure mode in which relatively large deflections occur while no member or part of the structure may have experienced fracture or plastic flow. We speak then of *elastic buckling*.

Beams are not the only structural elements that may experience elastic buckling. Indeed *all* structures in theory might buckle if the loading and boundary conditions are of the right sort. The task in the analysis of the possibility of *elastic instability* is to try to determine what load levels will bring on buckling.

Not all elastic instability qualifies as failure. In some designs we **want** buckling to occur. The Tin Man's oil-can in *The Wizard of Oz* was designed, as were all oil cans of this form, so that the bottom, when pushed hard enough, dished in with a snap, *snapped through*, and displaced just the right amount of oil out the long conical nozzle. Other latch mechanisms rely upon *snap-through* to lock a fastener closed.

But generally, buckling means failure and that failure is often *catastrophic*. To see why, we first consider a simple mechanism of little worth in itself as a mechanical device but valuable to us as an aid to illustrating the fundamental phenomenon. The link shown below is to be taken as rigid. It is fastened to ground through a frictionless pin but a linear, torsional spring of stiffness K_T resists rotation, any deviation from the vertical. A weight P is suspended from the free end.

We seek all possible static equilibrium configurations of the system. On the left is the one we postulate working from the perspective of small deflections and rotations; that is **up until now we have always considered equilibrium with respect to the undeformed configuration**. We can call this a *trivial solution*; the bar does not rotate, the reaction moment of the torsional spring is zero, the rigid link is in compression.

The one on the right is more interesting. But note; **we consider equilibrium with respect to a deformed configuration**.

Moment equilibrium requires that $M_T - P\Delta$

$$\text{or } \left(\frac{K_T}{PL}\right) \cdot \phi - \sin \phi = 0$$

Our challenge is to find values of ϕ which satisfy this equation for a given load P . We wish to plot how the load varies with displacement, the latter measured by either $\Delta = L\sin\phi$ or ϕ itself. That is the traditional problem we have posed to date. But note, this equation does not solve so easily; it is **nonlinear** in the displacement variable ϕ . Now when we enter the land of nonlinear algebraic equations, we enter a world where strange things can happen. We might, for example, encounter multi-valued solutions. That is the case here.

One branch of our solution is the trivial solution $\phi = 0$ for all values of P . This is the vertical axis of the plot below. (We plot the *nondimensional load* (PL/K_T) versus the *nondimensional horizontal displacement* (Δ/L)). But there exists another branch, one revealed by the geometric construction at the right. Here we

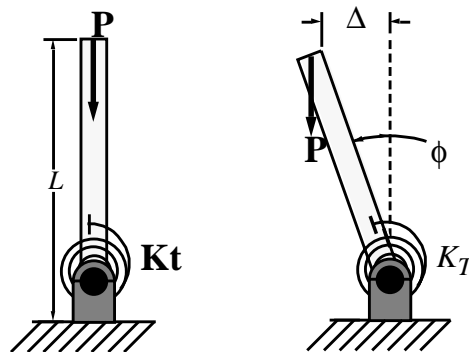

have plotted the straight line $y = (K_T/PL)\phi$, for various values of the load parameter, and the sine function $y = \sin\phi$ on the same graph.

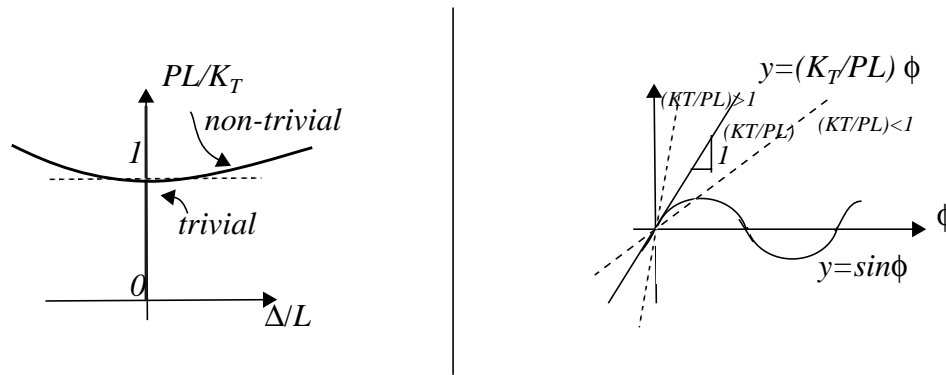

This shows that, for (K_T/PL) large, (or P small), there is no nontrivial solution. But when (K_T/PL) gets small, (or P grows large), intersections of the straight line with the sine curve exist and the nonlinear equilibrium equation has nontrivial solutions for the angular rotation. The transition value from no solutions to some solutions occurs when the slope of the straight line equals the slope of the sine function at $\phi = 0$, that is when $(K_T/PL)=1$, when

$$\frac{PL}{K_T} = 1$$

Here is a critical, very special, value if there ever was one. If the load P is less than K_T/L , **less than the critical value then we say the system is stable**. The link will not deflect. But beyond that all bets are off. What is the locus of equilibrium states beyond the critical load? We can, for this simple problem, construct this branch readily. We find nontrivial solutions, pairs of (PL/K_T) and ϕ values that satisfy equilibrium most readily by choosing values for ϕ and using the equation to compute the required value for the load parameter. I have plotted the branch that results above on the left.

You can imagine what will happen to our structure as we approach and exceed the critical value; up until the critical load any deflections will be insensible, in fact zero. This assumes the system has no imperfections say in the initial alignment of the link relative to vertical. If the latter existed, the link would show some small angular rotations even below the critical load. Once past the critical load we see very large deflections for relatively small increments in the load, and note the rigid bar could swing either to the right or to the left.

Another way to visualize the effect of exceeding the critical load is to imagine holding the mechanism straight while you take the load up, then, once past the critical value, say by 20%, let go... and stand back. The system will jump toward either equilibrium state possible at that load to the left or to the right¹.

The *critical value* is called the **buckling load**, often the **Euler buckling load**.

Before turning to the buckling of beams, we make one final and important observation: If in the equilibrium equation taken with respect to the deformed configuration, we say that ϕ , the deviation from the vertical is small, we can approximate $\sin\phi \approx \phi$ and our equilibrium equation takes *the linear, homogeneous form*

1. In reality the system would no doubt bounce around a good bit before returning to static equilibrium.

$$\left[1 - \left(\frac{PL}{K_T} \right) \right] \cdot \phi = 0$$

Now how do the solutions of this compare to what we have previously obtained? At first glance, not very well. It appears that the only solution is the trivial one, $\phi = 0$. But look! I can also claim a solution if the bracket out front is zero. This will happen for a special value, an *eigenvalue*, namely

$$\text{when } PL/K_T = 1.0.$$

Now that is a significant result for, even though we cannot say very much about the angular displacement, other than it can be anything at all, we have determined the critical buckling load **without having to solve a nonlinear equation**.

We will apply this same procedure in our analysis of the buckling of beams. To do so we need to develop an equation of equilibrium for a beam subject to a compressive load that includes the possibility of small but finite transverse displacements. We do this by considering again a differential element of a beam but now allow it to deform before writing equilibrium. The figure below shows the deformed element acted upon by a compressive load as well as a shear force and bending moment.

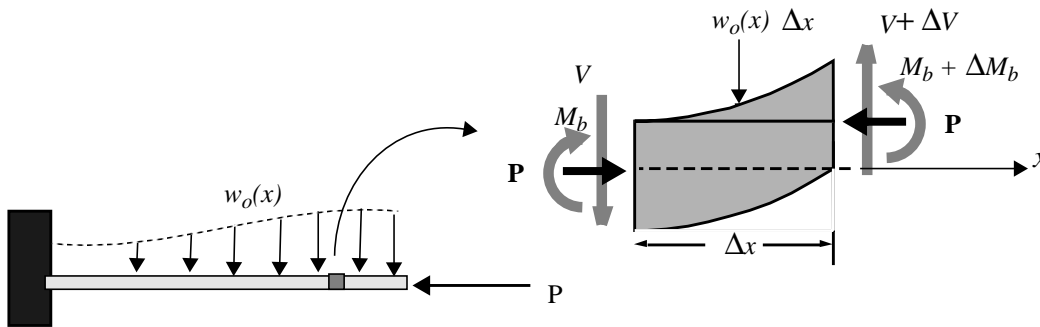

Force equilibrium in the horizontal direction is satisfied identically if we allow no variation of the axial load¹. Force equilibrium of the differential element in the vertical direction requires

$$-V - w_o \cdot \Delta x + (V + \Delta V) = 0$$

while moment equilibrium about the station x yields

$$-M_b - w_o \cdot \frac{(\Delta x)^2}{2} + (V + \Delta V) \cdot \Delta x + (M_b + \Delta M_b) + P \cdot \Delta v = 0$$

1. The buckling of a vertical column under its own distributed weight would mean that P would vary along the axis of the beam.

The last term in moment equilibrium is only there because we have taken **equilibrium with respect to the slightly deformed configuration**. In the limit as $\Delta x \rightarrow 0$ we obtain the two differential equations:

$$\frac{dV}{dx} = w_0(x)$$

and

$$\frac{dM_b}{dx} + V + P \cdot \frac{dv}{dx} = 0$$

It is important to distinguish between the lower case and upper case *v*; the former is the deflection of the neutral axis, the latter the shear force. We obtain a single equilibrium equation in terms of displacement by first differentiating the second equation with respect to x , then eliminate the term dV/dx using the first equation. I obtain

$$\frac{d^2 M_b}{dx^2} + P \cdot \frac{d^2 v}{dx^2} = -w_0(x)$$

We now phrase the bending moment in terms of displacement using the linearized form of the moment-curvature relation, $M_b/(EI) = d^2 v/dx^2$ and obtain

$$(EI) \cdot \frac{d^4 v}{dx^4} + P \cdot \frac{d^2 v}{dx^2} = 0$$

Along the way I have assumed that the applied distributed load $w_0(x)$ is zero. This is no great loss; it will have little influence on the behavior if the end load approaches the buckling load. It is a straight forward matter to take its effect into account. In order to focus on the buckling mechanism, we leave it aside.

This is a *fourth order, ordinary, linear differential, homogeneous equation* for the transverse displacement of the neutral axis of a beam subject to an end load, P . It must be supplemented by some boundary conditions on the displacement and its derivatives. Their expression depends upon the particular problem at hand. They can take the form of zero displacement or slope at a point, e.g.,

$$v = 0 \quad \text{or} \quad \frac{dv}{dx} = 0$$

They can also involve higher derivatives of $v(x)$ through conditions on the bending moment at a point along the beam, e.g., a condition on

$$M_b = (EI) \cdot \frac{d^2 v}{dx^2}$$

or on the shear force

$$V = -(EI) \cdot \frac{d^3 v}{dx^3} - P \frac{dv}{dx}$$

This last is a restatement of the differential equation for force equilibrium found above, which, since we increased the order of the system by differentiating the moment equilibrium equation, now appears as a boundary condition

Exercise 8.4 A beam of Length L , moment of inertia in bending I , and made of a material with Young's modulus E , is pinned at its left end but tied down at its other end by a linear spring of stiffness K . The beam is subjected to a compressive end load P .

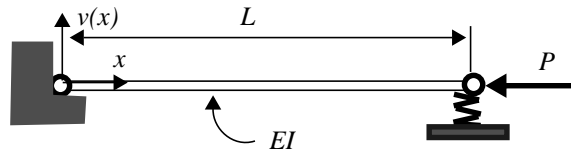

Show that the Euler buckling load(s) are determined from the equation

$$\left[\left(\frac{P}{KL} \right) - 1 \right] \sin \sqrt{PL^2/(EI)} = 0$$

Show also that it is possible for the system to go unstable without any elastic deformation of the beam. That is, it deflects upward (or downward), rotating about the left end as a rigid bar. Construct a relationship an expression for the stiffness of the linear spring relative to the stiffness of the beam when this will be the case, the most likely mode of instability.

We start with the general solution to the differential equation for the deflection of the neutral axis, that described by the function $v(x)$.

$$v(x) = c_1 + c_2x + c_3 \sin \sqrt{\frac{P}{EI}}x + c_4 \cos \sqrt{\frac{P}{EI}}x$$

Letting $\lambda^2 = (P/EI)$ this can be written more simply as

$$v(x) = c_1 + c_2x + c_3 \sin \lambda x + c_4 \cos \lambda x$$

In this, c_1 , c_2 , c_3 , and c_4 are constants which will be determined from the boundary conditions. The latter are as follows:

At the left end, $x=0$, the displacement vanishes so $v(0) = 0$ and since it is pinned, free to rotate there, the bending moment must also vanish $M_b(0) = 0$ or $d^2v/dx^2 = 0$ while at the right end, $x=L$, the end is free to rotate so the bending moment must be zero there as well: $M_b(L) = 0$ or $d^2v/dx^2 = 0$

The last condition (we need four since there are four constants of integration) requires drawing an isolation of the end. We see from force equilibrium of the tip of the beam that

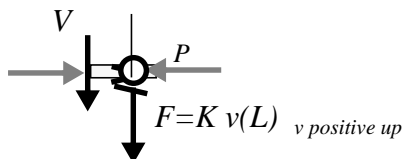

$$V + F = 0 \quad \text{or} \quad V + K v(L) = 0$$

where F is the force in the spring, positive if the end moves upward, and V , the shear force, is consistent with our convention set out prior to deriving the differential equation for $v(x)$. Expressing V in terms of the displacement $v(x)$ and its derivatives we can write our fourth boundary condition as:

$$d^3v/dx^3 + (P/EI)dv/dx - (K/EI)v(L) = 0 \quad \text{or} \quad d^3v/dx^3 + \lambda dv/dx - \beta v(L) = 0$$

where I have set $\beta = K/EI$.

To apply these to determine the c 's, we need expressions for the derivatives of $v(x)$, up to third order. We find

$$dv/dx = c_2 + c_3\lambda \cos\lambda x - c_4\lambda \sin\lambda x$$

$$d^2v/dx^2 = -c_3\lambda^2 \sin\lambda x - c_4\lambda^2 \cos\lambda x$$

$$d^3v/dx^3 = -c_3\lambda^3 \cos\lambda x + c_4\lambda^3 \sin\lambda x$$

With these, the boundary conditions become

at $x = 0$.

$$v(0)=0: \quad c_1 \quad \quad \quad + c_4 = 0$$

$$d^2v/dx^2 = 0: \quad \quad \quad + c_4 = 0$$

at $x = L$.

$$d^2v/dx^2 = 0: \quad \quad \quad (\lambda^2 \sin \lambda L) c_3 = 0$$

$$(\lambda^2 - \beta L) c_2 - (\sin \lambda L) c_3 = 0$$

Now these are four, linear homogeneous equations for the four constants, c_1 - c_4 . One solution is that they all be zero. This, if your were to report to your boss would earn your very early retirement. The *trivial solution* is not the only one. In fact there are many more solutions but only for special values for the end load P , (λ). We know from our prior studies of systems of linear algebraic equations that the only hope we have for finding non zero c 's is to have the determinant of the coefficients of the linear system be zero. The *eigenvalues* are obtained from this condition.

Rather than evaluate the determinant, we will proceed by an alternate path, no less decisive. From the second equation we must have $c_4 = 0$. Then, from the first we must have $c_1 = 0$.

Turning to the third equation, we might conclude that c_3 is zero as well. That would be a mistake. For we might have $\sin \lambda L = 0$.

Now consider the last two as two equations for c_2 and c_3 . The determinant of the coefficients is

$$(\lambda^2 - \beta \cdot L) \cdot \sin(\lambda L)$$

which, when set to zero, can be written

$$\left[\left(\frac{P}{KL} \right) - 1 \right] \sin \sqrt{PL^2/(EI)} = 0$$

This can be made zero in various ways.

- We can have

$$(P/KL) = 1$$

- or we can set

$$\sin [PL^2/(EI)]^{1/2} = 0 \quad \text{which has roots } PL^2/(EI) = \pi^2, 4\pi^2, 9\pi^2, \dots$$

The critical *eigenvalue* will be the lowest one, the one which gives the lowest value for the end load P . We see that this depends upon the stiffness of the linear spring relative to the stiffness of the beam as expressed by EI/L^3 . For the mode of instability implied by the equation $(P/KL) = 1$, we must have

$$P = KL < \pi^2 EI/L^2 \quad \text{or} \quad k/(EI/L^3) < \pi^2$$

If this be the case, then the coefficient of c_2 in the last of our four equations will be zero. At the same time, $\sin \lambda L$ will *not* be zero in general so c_3 must be zero. The only non-zero coefficient is c_2 and, our general solution to the differential equation is simply

$$v(x) = c_2 x$$

This particular *buckling mode* is to be read as a *rigid body rotation* about the left end.

If, on the other hand, the inequality goes the other way, then another mode of instability will be encountered when

$$P = \pi^2 EI/L^2$$

Now c_2 must vanish but c_3 can be arbitrary. Our deflected shape is in accord with

$$v(x) = c_3 \sin \lambda x$$

and is sketched below. Note in this case the linear spring at the end neither extends nor contracts.

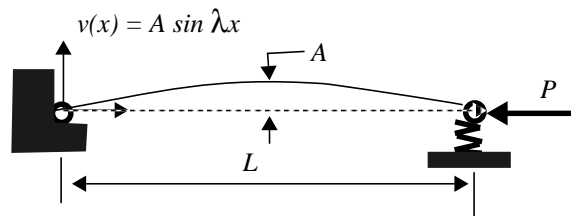

Observe

- There are still other special, or eigenvalues, which accompany other, *higher*, mode shapes. The next one, corresponding to $PL^2/EI = 4\pi^2$, would appear as a full sine wave. But since the lower critical mode is the most probable, you would rarely see this what remains as but a mathematical possibility.
- If we let K be very large relative to (EI/L^3) , we approach a beam pinned at both ends. The buckled beam would appear as in the figure above.
- Conversely, If we let K be very small relative to the beam's stiffness, we have a situation much like the system we previously studied namely a rigid bar pinned at an end but restrained by a torsional spring. In fact, we get the same buckling load if we set the K_T of the torsional spring equal to KL^2 .
- We only see the possibility of buckling if we consider **equilibrium with respect to the deformed configuration.**

8.3 Matrix Analysis of Frame Structures

We return to the use of the computer as an essential tool for predicting the behavior of structures and develop a method for the analysis of internal stresses, the deformations, displacements and rotations of structures made up of beams, beam elements rigidly fixed one to another in some pattern designed to, as is our habit, to support some externally applied loads. We call structures built up of beam elements, *frames*.

Frames support modern skyscrapers; your bicycle is a frame structure; a cantilevered balcony might be girded by a frame. If the structure's members are intended to support the externally applied loads via *bending*, the structure is a *frame*.

As we did with *truss* structures, structures that are designed to support the externally applied loads via *tension and compression* of its members, we use a *displacement method*. Our final system of equations to be solved by the machine will be the equilibrium equations expressed in terms of displacements.

The figure shows a frame, a building frame, subject to side loading, say due to wind. These structural members are not pinned at their joints. If they were, the frame would collapse; there would be no resistance to the shearing of one floor relative to another. The structural members are rigidly fixed to one another at their joints. So the joints can transmit a bending moment from one element to another.

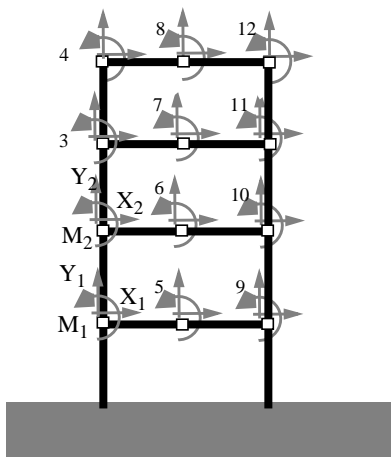
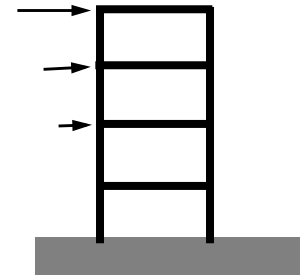

The figure at the left shows how we might model the frame as a collection of discrete, beam elements. The number of elements is quite arbitrary. Just how many elements is sufficient will depend upon several factors, e.g., the spatial variability of the externally applied loads, the homogeneity of the materials out of which the elements are made, the desired "accuracy" of the results.

In this model, we represent the structure as an assemblage of 16 elements, 8 horizontal, two for each floor, and 8 vertical. At each node there are three degrees of freedom: a horizontal displacement, a vertical displacement, and the rotation at the node. This is one more degree of freedom than appeared at each node of our (two-dimensional) truss structure. This is because the geometric boundary conditions at the ends, or junction, of a beam element include the slope as well as the displacement.

With 12 nodes and 3 degrees of freedom per node, our structure has a total of 36 degrees of freedom; there are 36 displacements and rotations to be determined. We indicate the applied external force components acting at but two of the nodes: X_1 , Y_1 act at node 1 for example; M_1 stands for an applied couple at the same node, but we do not show the corresponding components of displacement and rotation.

Equilibrium in terms of displacement will require 36 linear, simultaneous equations to be solved. This presents no problem for our machinery.

We will construct the system of 36 equilibrium equations in terms of displacement by directly evaluating the entries of the whole structure's stiffness matrix. To do this, we need to construct the stiffness matrix for each individual beam element, then assemble the stiffness matrix for the entire structure by superimposition. What this means will become clear, I hope, in what follows.

Our approach differs from the way we treated truss structures. There we constructed the equilibrium equations by isolating each node of the truss; then wrote down a set of force-deformation relations for each truss member; then another matrix equation relating the member deformations to the displacement components of the nodes. We then eliminated the member forces in terms of these nodal displacements in the equilibrium equations to obtain the overall or global stiffness matrix for the entire truss structure. Only at this point, at the end of our construction, did we point out that that each column of the stiffness matrix can be interpreted as the forces required to maintain equilibrium for a unit displacement corresponding to that column, all other displacements being held to zero. This is the way we will proceed from the start, now, constructing first the stiffness matrix for a horizontal beam element.

The figure at the right shows such an element. At each of its end nodes, we allow for an axial, a transverse force and a couple. These are assumed to be positive in the directions shown. The displacement components at each of the two ends - v_1, v_2 , in the transverse direction, u_1, u_2 , in the axial direction - and the slopes at the ends, ϕ_1 and ϕ_2 , are also indicated; all of these are positive in the directions shown.

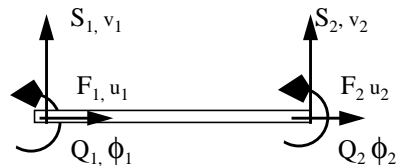

The bottom figure shows a possible deformed state where the displacements and rotations are shown more clearly (save u_2).

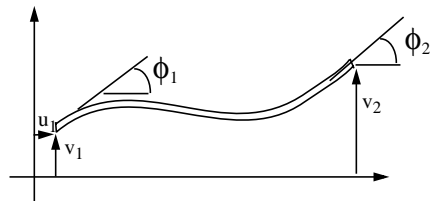

Our first task is to construct the entries in the stiffness matrix for this beam element. It will have the form:

$$\begin{bmatrix} F_1 \\ S_1 \\ Q_1 \\ F_2 \\ S_2 \\ Q_2 \end{bmatrix} = \begin{bmatrix} u_1 \\ v_1 \\ \phi_1 \\ u_2 \\ v_2 \\ \phi_2 \end{bmatrix}$$

A basic feature of matrix multiplication, of this expression, is the following: each column may be interpreted as the force and moment components, the left side of the equation, that are required to maintain a deformed configuration of a unit displacement corresponding to that column and zero displacements and rotations otherwise. For example, the entries in the first column may be interpreted as F_1, S_1, \dots, Q_2 for the displacement

$$u_1 = 1 \quad \text{and} \quad v_1 = \phi_1 = u_2 = v_2 = \phi_2 = 0$$

This turns out to be a particularly easy column to fill in, for this deformation state, shown in the figure, only requires axial forces F_1 and F_2 to induce this displacement and maintain equilibrium.

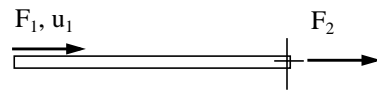

In fact, if $u_1 = 1$, then the force required to produce this unit displacement is just (AE/L) . This means that F_2 , in this case, must, in order for equilibrium to hold, be equal to $-(AE/L)$. No other forces or moments are required or engendered. Hence all other elements of the first column of the stiffness matrix, the column corresponding to u_1 , must be zero.

The elements of the fourth column, the column corresponding to the displacement u_2 , are found just as easily. In this case $F_2 = (AE/L)$ and $F_1 = - (AE/L)$ for equilibrium. Our stiffness matrix now has the form shown at the right. We continue considering the second column and envision the displace configuration

$$v_1 = 1 \quad \text{and} \quad u_1 = \phi_1 = u_2 = v_2 = \phi_2 = 0.$$

$$\begin{bmatrix} F_1 \\ S_1 \\ Q_1 \\ F_2 \\ S_2 \\ Q_2 \end{bmatrix} = \begin{bmatrix} \frac{AE}{L} & 0 & ? & -\frac{AE}{L} & ? & ? \\ 0 & ? & 0 & ? & ? & ? \\ 0 & ? & 0 & ? & ? & ? \\ -\frac{AE}{L} & 0 & ? & \frac{AE}{L} & ? & ? \\ 0 & ? & 0 & ? & ? & ? \\ 0 & ? & 0 & ? & ? & ? \end{bmatrix} \begin{bmatrix} u_1 \\ v_1 \\ \phi_1 \\ u_2 \\ v_2 \\ \phi_2 \end{bmatrix}$$

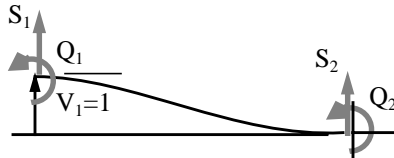

The figure at the left shows the deformed state. In this it appears we will require a S_1 and a Q_1 but no axial force. Remember, we assume small displacements and rotations so the axial force does not effect the bending of the beam element (and, similarly, bending of the beam does not induce any axial deformation). Only if we allow greater than small displacements and rotations will an axial load effect bending; this was the case in buckling but we are not allowing for buckling.

To determine what end force S_1 , and what end couple, Q_1 , are required to make the vertical displacement at the end of a cantilever equal 1 and the slope there zero - it's a cantilever because the vertical displacement and rotation at the right end must be zero -we make use of the known expressions for the tip displacement and rotation due to an end load and an end couple, then superimpose the two to ensure a vertical displacement of 1 and rotation of zero.

For a vertical, end load S_1 , we have from the relationships given on page 182 ,

$$v_1 = \left(\frac{L^3}{3EI}\right) \cdot S_1 \quad \text{and} \quad \frac{dv}{dx}\Big|_1 = \phi_1 = -\left(\frac{L^2}{2EI}\right)$$

For an end couple, Q_1 , we have

$$v_1 = -\left(\frac{L^2}{2EI}\right) \cdot Q_1 \quad \text{and} \quad \phi_1 = \left(\frac{L}{EI}\right) \cdot Q_1$$

If both a vertical force and a couple act, then, superimposing, we obtain the following two equations for determining the vertical displacement and the rotation at the end of the beam:

$$v_1 = \left(\frac{L^3}{3EI}\right) \cdot S_1 - \left(\frac{L^2}{2EI}\right) \cdot Q_1$$

$$\phi_1 = -\left(\frac{L^2}{2EI}\right) \cdot S_1 + \left(\frac{L}{EI}\right) \cdot Q_1$$

Now we set the vertical displacement equal to unity, $v_1 = 1$, and the slope zero, $\phi_1 = 0$, and solve these 2 equations for the required end load S_1 and the required end couple Q_1 . We obtain:

$$S_1 = (12EI/L^3) \quad \text{and} \quad Q_1 = (6EI/L^2)$$

The force and couple at the right end of the element are obtained from equilibrium. Without even drawing a free body diagram (living dangerously) we have:

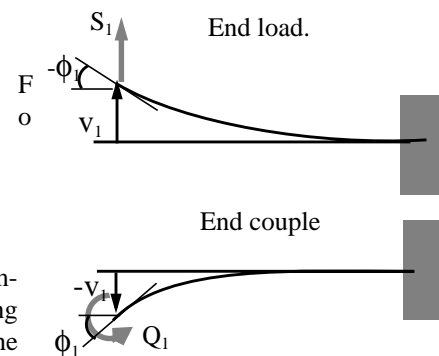

$$S_2 = - (12EI/L^3) \quad \text{and} \quad Q_2 = (6EI/L^2)$$

Thus the elements of the second column of the matrix are found and our stiffness matrix now has the form shown.

$$\begin{bmatrix} F_1 \\ S_1 \\ Q_1 \\ F_2 \\ S_2 \\ Q_2 \end{bmatrix} = \begin{bmatrix} \frac{AE}{L} & 0 & ? & -\frac{AE}{L} & ? & ? \\ 0 & \frac{12EI}{L^3} & ? & 0 & ? & ? \\ 0 & \frac{6EI}{L^2} & ? & 0 & ? & ? \\ -\frac{AE}{L} & 0 & ? & \frac{AE}{L} & ? & ? \\ 0 & -\frac{12EI}{L^3} & ? & 0 & ? & ? \\ 0 & \frac{6EI}{L^2} & ? & 0 & ? & ? \end{bmatrix} \begin{bmatrix} u_1 \\ v_1 \\ \phi_1 \\ u_2 \\ v_2 \\ \phi_2 \end{bmatrix}$$

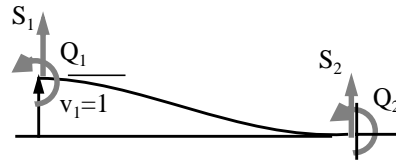

The elements of the third column, corresponding to a unit rotation $\phi_1 = 1$ and all other displacements and rotations zero, are found again from two simultaneous equations but now we find, with $v_1 = 0$ and $\phi_1 = 1$:

$$S_1 = (6EI/L^2) \quad \text{and} \quad Q_1 = (4EI/L)$$

Again, the force and couple at the right end are obtained from equilibrium. Now we have:

$$S_2 = - (6EI/L^2) \quad \text{and} \quad Q_2 = (2EI/L)$$

With this, our stiffness matrix becomes as shown at the right.

$$\begin{bmatrix} F_1 \\ S_1 \\ Q_1 \\ F_2 \\ S_2 \\ Q_2 \end{bmatrix} = \begin{bmatrix} \frac{AE}{L} & 0 & 0 & -\frac{AE}{L} & ? & ? \\ 0 & \frac{12EI}{L^3} & \frac{6EI}{L^2} & 0 & ? & ? \\ 0 & \frac{6EI}{L^2} & \frac{4EI}{L} & 0 & ? & ? \\ -\frac{AE}{L} & 0 & 0 & \frac{AE}{L} & ? & ? \\ 0 & -\frac{12EI}{L^3} & -\frac{6EI}{L^2} & 0 & ? & ? \\ 0 & \frac{6EI}{L^2} & \frac{2EI}{L} & 0 & ? & ? \end{bmatrix} \begin{bmatrix} u_1 \\ v_1 \\ \phi_1 \\ u_2 \\ v_2 \\ \phi_2 \end{bmatrix}$$

Proceeding in a similar way at the right end of the beam element, we can construct the elements of the final two columns corresponding to a unit displacement, $v_2 = 1$ (the fifth column) and a unit rotation at the end, $\phi_2 = 1$, (the sixth column). Our final result is:

$$\begin{bmatrix} F_1 \\ S_1 \\ Q_1 \\ F_2 \\ S_2 \\ Q_2 \end{bmatrix} = \begin{bmatrix} \frac{AE}{L} & 0 & 0 & -\frac{AE}{L} & 0 & 0 \\ 0 & \frac{12EI}{L^3} & \frac{6EI}{L^2} & 0 & -\frac{12EI}{L^3} & \frac{6EI}{L^2} \\ 0 & \frac{6EI}{L^2} & \frac{4EI}{L} & 0 & -\frac{6EI}{L^2} & \frac{2EI}{L} \\ -\frac{AE}{L} & 0 & 0 & \frac{AE}{L} & 0 & 0 \\ 0 & -\frac{12EI}{L^3} & -\frac{6EI}{L^2} & 0 & \frac{12EI}{L^3} & -\frac{6EI}{L^2} \\ 0 & \frac{6EI}{L^2} & \frac{2EI}{L} & 0 & -\frac{6EI}{L^2} & \frac{4EI}{L} \end{bmatrix} \begin{bmatrix} u_1 \\ v_1 \\ \phi_1 \\ u_2 \\ v_2 \\ \phi_2 \end{bmatrix}$$

Exercises 8.5 Construct the stiffness matrix for the simple frame structure shown.

We employ the same approach as used in constructing the stiffness matrix for the single, horizontal beam element. We consider a unit displacement of each degree of freedom — $U_1, V_1, \Phi_1, U_2, V_2,$ and Φ_2 — constructing the corresponding column of the stiffness matrix of the whole structure in turn. Note how we use capital letters to specify the displacements and rotations of each node relative to a *global coordinate* reference frame.

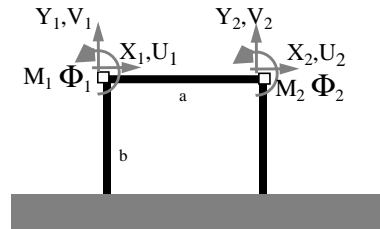

$$\begin{matrix} V_1 = 0 \\ \Phi_1 = 0 \end{matrix}$$

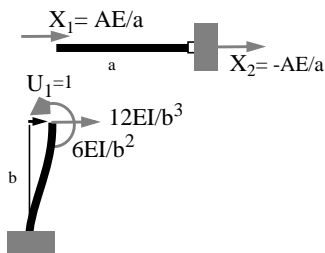

We start, taking $U_1 = 1$, and consider what force and moment components are required to both produce this displacement and ensure equilibrium at the nodes. Since all other displacement and rotation components are zero, we draw the deformed configuration at the left. Referring to the previous figure, we see that we must have a horizontal force of magnitude $AE/a + 12EI/b^3$ applied at node #1, and a moment of magnitude $6EI/b^2$ to maintain this deformation. There is no vertical force required at node #1.

At node #2, we see we must apply, for equilibrium of the horizontal beam element, an equal and opposite force to $X_1 = AE/a$. No other externally applied forces are required.

Thus, the first column of our stiffness matrix appears as shown at the right:

Entries in the second column are obtained by setting $V_1 = 1$ and all other displacement components zero. The deformed state looks as below;

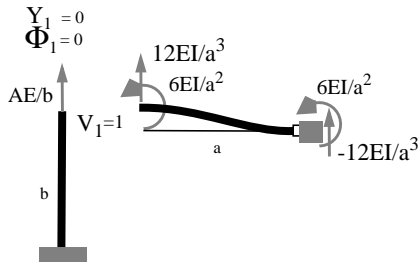

$$\begin{bmatrix} X_1 \\ Y_1 \\ M_1 \\ X_2 \\ Y_2 \\ M_2 \end{bmatrix} = \begin{bmatrix} \frac{AE}{a} + \frac{12EI}{b^3} & ? & ? & ? & ? & ? \\ 0 & ? & ? & ? & ? & ? \\ \frac{6EI}{b^2} & ? & ? & ? & ? & ? \\ -\frac{AE}{a} & ? & ? & ? & ? & ? \\ 0 & ? & ? & ? & ? & ? \\ 0 & ? & ? & ? & ? & ? \end{bmatrix} \begin{bmatrix} U_1 \\ V_1 \\ \Phi_1 \\ U_2 \\ V_2 \\ \Phi_2 \end{bmatrix}$$

The forces and moments required to engender this state and maintain equilibrium are obtained from the *local* stiffness matrix for a single beam element on the previous page. Thus, the second column of our stiffness matrix can be filled in:

$$\begin{bmatrix} X_1 \\ Y_1 \\ M_1 \\ X_2 \\ Y_2 \\ M_2 \end{bmatrix} = \begin{bmatrix} \frac{AE}{a} + \frac{12EI}{b^3} & 0 & ? & ? & ? & ? \\ 0 & \frac{AE}{b} + \frac{12EI}{a^3} & ? & ? & ? & ? \\ \frac{6EI}{b^2} & \frac{6EI}{a^2} & ? & ? & ? & ? \\ -\frac{AE}{a} & 0 & ? & ? & ? & ? \\ 0 & -\frac{12EI}{a^3} & ? & ? & ? & ? \\ 0 & \frac{6EI}{a^2} & ? & ? & ? & ? \end{bmatrix} \begin{bmatrix} U_1 \\ V_1 \\ \Phi_1 \\ U_2 \\ V_2 \\ \Phi_2 \end{bmatrix}$$

Continuing in this way, next setting $F_1 = 1$, all other displacements zero, sketching the deformed state, reading off the required force and moment components to maintain this deformed state and superim-

posing corresponding components at each of the two nodes, produces the stiffness matrix for the whole structure. We obtain:

$$\begin{bmatrix} X_1 \\ Y_1 \\ M_1 \\ X_2 \\ Y_2 \\ M_2 \end{bmatrix} = \begin{bmatrix} \frac{AE}{a} + \frac{12EI}{b^3} & 0 & \frac{6EI}{b^2} & -\frac{AE}{a} & 0 & 0 \\ 0 & \frac{AE}{b} + \frac{12EI}{a^3} & \frac{6EI}{a^2} & 0 & -\frac{12EI}{a^3} & \frac{6EI}{a^2} \\ \frac{6EI}{b^2} & \frac{6EI}{a^2} & \frac{4EI}{b} + \frac{4EI}{a} & 0 & -\frac{6EI}{a^2} & \frac{2EI}{a} \\ -\frac{AE}{a} & 0 & 0 & \frac{AE}{a} + \frac{12EI}{b^3} & 0 & \frac{6EI}{b^2} \\ 0 & -\frac{12EI}{a^3} & -\frac{6EI}{a^2} & 0 & \frac{AE}{b} + \frac{12EI}{a^3} & -\frac{6EI}{a^2} \\ 0 & \frac{6EI}{a^2} & \frac{2EI}{a} & \frac{6EI}{b^2} & -\frac{6EI}{a^2} & \frac{4EI}{a} + \frac{4EI}{b} \end{bmatrix} \begin{bmatrix} U_1 \\ V_1 \\ \Phi_1 \\ U_2 \\ V_2 \\ \Phi_2 \end{bmatrix}$$

8.4 Energy Methods

Just as we did for Truss Structures, so the same perspective can be entertained for beams.

8.4.1 A Virtual Force Method for Beams

The intent here is to develop a way of computing the displacements of a (statically determinate) beam under arbitrary loading and just as arbitrary boundary conditions without making explicit reference to compatibility conditions, i.e. without having to integrate the differential equation for transverse displacements. The approach mimics that taken in the section on Force Method #1 as applied to statically determinate truss structures.

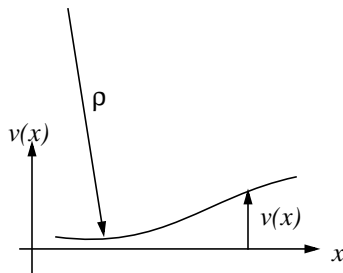

We start with the compatibility condition which relates the curvature, $\kappa = 1/\rho$, to the transverse displacement, $v(x)$,

$$\kappa = \frac{d^2}{dx^2}v(x)$$

and take a totally unmotivated step, multiplying both side of this equation by a function of x which can be anything whatsoever, we integrate over the length of the beam:

$$\int_0^L \kappa \cdot M^*(x) \cdot dx = \int_0^L M^*(x) \cdot \frac{d^2}{dx^2}v(x) \cdot dx$$

This arbitrary function bears an asterisk to distinguish it from the actual bending moment distribution in the structure.

At this point, the function M^* could be any function we wish, but now we manipulate this relationship, integrating the right hand side by parts and so obtain

$$\int_0^L \kappa \cdot M^*(x) \cdot dx = M^* \cdot \frac{dv}{dx} \Big|_0^L - \int_0^L \frac{dv}{dx} \cdot \frac{dM^*}{dx} \cdot dx$$

Integrating by parts once again, we have

$$\int_0^L \kappa \cdot M^*(x) \cdot dx = M^* \cdot \frac{dv}{dx} \Big|_0^L - \frac{d}{dx}(M^*) \cdot v \Big|_0^L + \int_0^L v \cdot \frac{d^2 M^*}{dx^2} \cdot dx$$

then consider the function $M^*(x)$ to be a *bending moment distribution*, **any** bending moment distribution that satisfies the equilibrium requirement for the beam, i.e.,

$$\frac{d^2}{dx^2}M^*(x) = p^*(x)$$

So $p^*(x)$ is arbitrary, because $M^*(x)$ is quite arbitrary - we can envision many different applied loads functions.

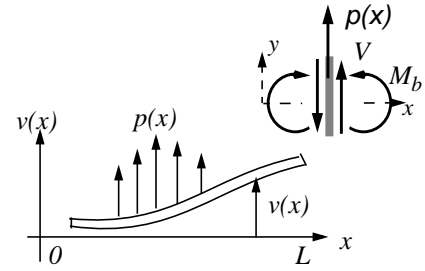

With this our compatibility relationship pre-multiplied by our arbitrary function, now read as a bending moment distribution, becomes

$$\int_0^L \kappa \cdot M^*(x) \cdot dx = M^* \cdot \frac{dv}{dx} \Big|_0^L - \frac{d}{dx}(M^*) \cdot v \Big|_0^L + \int_0^L p^*(x) \cdot v(x) \cdot dx$$

(Note: the dimensions of the quantity on the left hand side of this last equation are force times length or work. The dimensions of the integral and boundary terms on the right hand side must be the same).

Now we choose $p^*(x)$ in a special way; we take it to be a unit load at a single point along the beam, all other loading zero. For example, we take

$$p^*(x) = 1 \cdot \delta(x - a)$$

a unit load in the vertical direction at a distance a along the x axis.

Carrying out the integration in the equation above, we obtain just the displacement at the point of application, at $x = a$, i.e.,

$$v(a) = \int_0^L \kappa \cdot M^*(x;a) \cdot dx + M^* \cdot \frac{dv}{dx} \Big|_0^L - \frac{d}{dx}(M^*) \cdot v \Big|_0^L$$

We can put this last equation in terms of bending moments alone using the moment/curvature relationship, and obtain:

$$v(a) = \int_0^L \frac{M(x)}{EI} \cdot M^*(x;a) \cdot dx + M^* \cdot \frac{dv}{dx} \Big|_0^L - \frac{d}{dx}(M^*) \cdot v \Big|_0^L$$

And that is our special method for determining displacements of a statically determinate beam. It requires, first, solving equilibrium for the "actual" bending moment given the "actual" applied loads. We then solve *another* equilibrium problem - one in which we apply a unit load at the point where we seek to determine the displacement and in the direction of the sought after displacement. With this bending moment distribution determined from equilibrium, we carry out the integration in this last equation and there we have it.

Note: We can always choose the "starred" loading such that the "boundary terms" in this last equation all vanish. Some of the four terms will vanish because of vanishing of the displacement or the slope at a boundary. (The unstarred quantities must satisfy the boundary conditions on the actual problem). Granting this, we have more simply

$$v(a) = \int_0^L \frac{M(x)}{EI} \cdot M^*(x;a) \cdot dx$$

We emphasize the difference between the two moment distributions appearing in this equation; $M(x)$, in plain font, is the actual bending moment distribution in the beam, given the actual applied loads. $M^*(x)$, with the asterisk, on the other hand, is some originally arbitrary, bending moment distribution which satisfies equilibrium - an equilibrium solution for the bending moment corresponding to a **unit load** in the vertical direction at the point $x=a$.

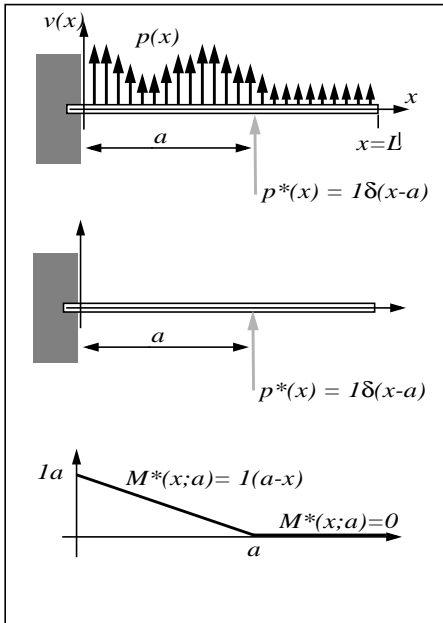

As an example, we consider a cantilever beam subject to a distributed load $p(x)$, which for now, we allow to be any function of distance along the span. We seek the vertical displacement at $x=a$.

We determine the bending moment distribution corresponding to the unit load at a . This is shown in the figure at the left, at the bottom of the frame. With this, our expression for the displacement at a becomes:

$$v(a) = \int_0^a \frac{M(x)}{EI} \cdot (a-x) \cdot dx$$

Note that:

- i) M^* at $x=L$ and $S^* (= dM^*/dx)$ at $x=L$ are zero so the two boundary terms in the more general expression for $v(a)$ vanish.
- ii) At the root, $v=0$ and $f (= dv/dx) = 0$ so the two boundary terms in the more general expression for $v(a)$ vanish.

iii) Finally, note that since the bending moment $M^*(x;a)$ is zero for $x > a$, the limit of integration in the above equation can be set to a .

We now simplify the example by taking our distributed load to be a constant, $p(x) = p_0$.

From the free body diagram at the right, we find

$$M(x) = p_0 \cdot (L-x)^2 / 2$$

and so the integral left to evaluate is:

$$v(a) = \int_0^a \frac{p_0 \cdot (L-x)^2 / 2}{EI} \cdot (a-x) \cdot dx = \frac{p_0}{2EI} \cdot \int_0^a (L-x)^2 \cdot (a-x) \cdot dx$$

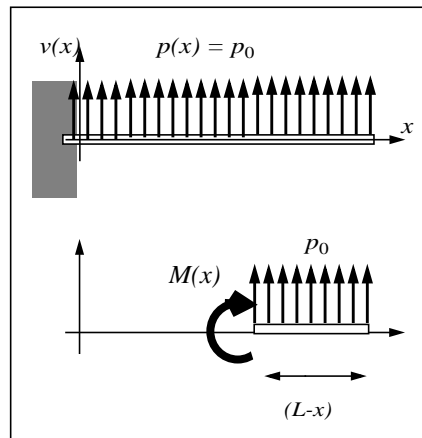

which, upon evaluation yields

$$v(a) = \frac{P_0}{24EI} \cdot (6a^2L^2 - 4a^3L + a^4)$$

Again, the significant thing to note is that we have produced an expression for the transverse displacement of the beam without confrontation with the differential equation for displacement! Our method is a force method requiring only the solution of (moment) equilibrium twice over.

8.4.2 A Virtual Displacement Method for Beams

The game now is to construct the stiffness matrix for a beam element using displacement and deformation/displacement considerations alone. We consider a beam element, uniform in cross-section and of length L , whose end displacements and rotations are prescribed and we are asked to determine the end forces and moments required to produce this system of displacements.

In the figure at the right, we show the beam element, deformed with prescribed end displacements v_1, v_2 , and prescribed end rotations ϕ_1, ϕ_2 . The task is to find the end forces, S_1, S_2 and end moments Q_1, Q_2 , that will produce this deformed state and be in equilibrium and we want to do this without having to consider equilibrium explicitly.

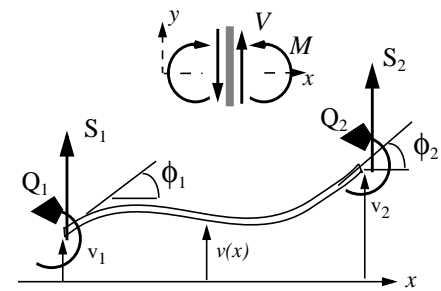

We start with equilibrium:¹

$$\frac{dV}{dx} = 0$$

$$\frac{dM}{dx} + V(x) = 0$$

and take a totally unmotivated step, multiplying the first of these equations, the one ensuring force equilibrium in the vertical direction, by some function $v^*(x)$ and the second, the one ensuring moment equilibrium at any point along the element, by another function $\phi^*(x)$, then integrate the sum of these products over the length of the element.

$$\int_0^L \frac{dV}{dx} \cdot v^*(x) \cdot dx + \int_0^L \left[\frac{dM}{dx} + V(x) \right] \cdot \phi^*(x) \cdot dx = 0$$

The functions $v^*(x)$ and $\phi^*(x)$ are quite arbitrary; at this stage in our game they could be anything whatsoever and still the above would hold true, as long as the shear force and bending moment vary in accord with the equilibrium requirements. They bear an asterisk to distinguish them from the actual displacement and rotation at any point along the beam element.

1. Note: our convention for positive shear force and bending moment is given in the figure.

Now we manipulate this relationship, integrating by parts, noting that:

$$\int_0^L \frac{dV}{dx} \cdot v^*(x) \cdot dx = v^* \cdot V|_0^L - \int_0^L V(x) \frac{dv^*}{dx} \cdot dx$$

and

$$\int_0^L \frac{dM}{dx} \cdot \phi^*(x) \cdot dx = \phi^* \cdot M|_0^L - \int_0^L M(x) \frac{d\phi^*}{dx} \cdot dx$$

and write

$$0 = v^* \cdot V|_0^L + \phi^* \cdot M|_0^L - \int_0^L \left\{ V(x) \left[\frac{dv^*}{dx} - \phi^*(x) \right] + M(x) \left[\frac{d\phi^*}{dx} \right] \right\} \cdot dx$$

Now from the figure, we identify the internal shear force and bending moments acting at the ends with the applied end forces and moments, that is

$$S_1 = -V(0), \quad Q_1 = -M(0), \quad S_2 = +V(L), \quad \text{and} \quad Q_2 = +M(L).$$

so we can write

$$v_1^* \cdot S_1 + \phi_1^* \cdot Q_1 + v_2^* \cdot S_2 + \phi_2^* \cdot Q_2 = \int_0^L \left\{ V(x) \left[\frac{dv^*}{dx} - \phi^*(x) \right] + M(x) \left[\frac{d\phi^*}{dx} \right] \right\} \cdot dx$$

We now restrict our choice of the arbitrary functions $v^*(x)$ and $\phi^*(x)$ ¹. We associate the first with a transverse displacement and the second with a rotation while requiring that there be no transverse shear deformation, i.e, plane cross sections remain plane and perpendicular to the neutral axis. In this case

$$\frac{dv^*}{dx} - \phi^*(x) = 0$$

so the first term in the integral on the right hand side vanishes, leaving us with the following;

$$v_1^* \cdot S_1 + \phi_1^* \cdot Q_1 + v_2^* \cdot S_2 + \phi_2^* \cdot Q_2 = \int_0^L M(x) \frac{d^2 v^*}{dx^2} \cdot dx$$

1. Actually we have already done so, insisting that they are continuous to the extent that their first derivatives exist and are integrable, in order to carry through the integration by parts.

We can cast the integrand into terms of member deformations alone (and member stiffness, EI), by use of the moment curvature relationship

$$M(x) = EI \cdot \frac{d^2 v}{dx^2}$$

and write

$$v_1^* \cdot S_1 + \phi_1^* \cdot Q_1 + v_2^* \cdot S_2 + \phi_2^* \cdot Q_2 = \int_0^L EI \cdot \frac{d^2 v}{dx^2} \cdot \frac{d^2 v^*}{dx^2} \cdot dx$$

And that will serve as our special method for determining the external forces and moments, acting at the ends, given the prescribed displacement field $v(x)$. The latter must be in accord with equilibrium, our starting point; that is

$$\frac{d^2 M}{dx^2} = 0 \quad \text{so from the moment/curvature relation} \quad \frac{d^4 v}{dx^4} = 0$$

Thus $v(x)$, our prescribed displacement along the beam element, has the form:

$$v(x) = a_0 + a_1 \cdot x + a_2 \cdot x^2 + a_3 \cdot x^3 \quad \text{and} \quad \frac{d^2 v}{dx^2} = 2a_2 + 6a_3 \cdot x$$

With this, our relationship among end forces, end moments, and prescribed displacements becomes

$$v_1^* \cdot S_1 + \phi_1^* \cdot Q_1 + v_2^* \cdot S_2 + \phi_2^* \cdot Q_2 = \int_0^L EI \cdot (2a_2 + 6a_3 \cdot x) \cdot \frac{d^2 v^*}{dx^2} \cdot dx$$

The coefficients a_2 and a_3 , as well as a_0 and a_1 , can be related to the end displacements and rotations, v_1 , ϕ_1 , v_2 and ϕ_2 but we defer that task for the moment.

Instead, we choose a $v^*(x)$ to give a unit displacement $v_1^* = 1$ and the other end displacement and rotations to be 0. There are many functions that will do the job; we take

$$v^*(x) = \frac{1}{2} \cdot \left(1 + \cos \frac{\pi x}{L} \right)$$

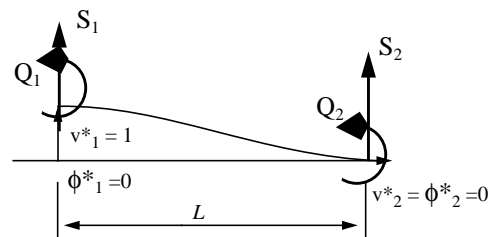

differentiate twice, and carry out the integration to obtain

$$S_1 = EI \cdot 6a_3$$

Now we relate the a 's to the end displacements and rotations. With

$$v_1 = v(0) = a_0$$

$$\phi_1 = \left. \frac{dv}{dx} \right|_0 = a_1$$

and

$$v_2 = v(L) = a_0 + a_1 \cdot L + a_2 \cdot L^2 + a_3 \cdot L^3$$

$$\phi_2 = \left. \frac{dv}{dx} \right|_L = a_1 + 2a_2 \cdot L + 3a_3 \cdot L^2$$

we solve for the a 's and obtain

$$a_0 = v_1$$

$$a_1 = \phi_1$$

$$a_2 = -\left(\frac{3}{L^2}\right)v_1 - \left(\frac{2}{L}\right)\phi_1 + \left(\frac{3}{L^2}\right)v_2 - \left(\frac{1}{L}\right)\phi_2$$

$$a_3 = \left(\frac{2}{L^3}\right) \cdot v_1 + \left(\frac{1}{L^2}\right) \cdot \phi_1 - \left(\frac{2}{L^3}\right) \cdot v_2 + \left(\frac{1}{L^2}\right) \cdot \phi_2$$

which then yields the following result for the end force required, S_1 , for prescribed end displacements and rotations v_1 , ϕ_1 , v_2 , and ϕ_2 .

$$S_1 = \left(\frac{12EI}{L^3}\right) \cdot v_1 + \left(\frac{6EI}{L^2}\right) \cdot \phi_1 - \left(\frac{12EI}{L^3}\right) \cdot v_2 + \left(\frac{6EI}{L^2}\right) \cdot \phi_2$$

The same ploy can be used to obtain the end moment Q_1 required for prescribed end displacements and rotations v_1 , ϕ_1 , v_2 , and ϕ_2 . We need but choose our arbitrary function $v^*(x)$ to give a unit rotation $\phi_1^* = dv^*/dx = 1$ at the left end, $x=0$, and the other end displacements and rotations to be 0. There are many functions that will do the job; we take

$$v^*(x) = x - 2L(x/L)^3 + L(x/L)^5$$

differentiate twice, and carry out the integration to obtain

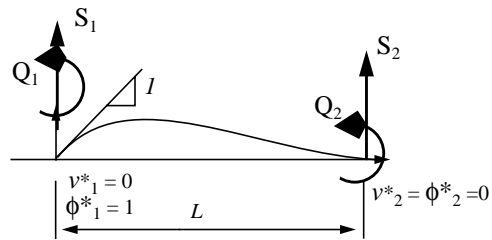

$$Q_1 = -EI \cdot 2a_2$$

which then yields the following result for the end moment required, Q_1 , for prescribed end displacements and rotations v_1 , ϕ_1 , v_2 , and ϕ_2 .

$$Q_1 = \left(\frac{6EI}{L^2}\right) \cdot v_1 + \left(\frac{4EI}{L}\right) \cdot \phi_1 - \left(\frac{6EI}{L^2}\right) \cdot v_2 + \left(\frac{2EI}{L^2}\right) \cdot \phi_2$$

In a similar way, expressions for the end force and moment at the right end, $x=L$ are obtained. Putting this all together produces the stiffness matrix:

$$\begin{bmatrix} S_1 \\ Q_1 \\ S_2 \\ Q_2 \end{bmatrix} = \begin{bmatrix} \frac{12EI}{L^3} & \frac{6EI}{L^2} & -\frac{12EI}{L^3} & \frac{6EI}{L^2} \\ \frac{6EI}{L^2} & \frac{4EI}{L} & -\frac{6EI}{L^2} & \frac{2EI}{L} \\ -\frac{12EI}{L^3} & -\frac{6EI}{L^2} & \frac{12EI}{L^3} & -\frac{6EI}{L^2} \\ \frac{6EI}{L^2} & \frac{2EI}{L} & -\frac{6EI}{L^2} & \frac{4EI}{L} \end{bmatrix} \begin{bmatrix} v_1 \\ \phi_1 \\ v_2 \\ \phi_2 \end{bmatrix}$$

Once again we obtain a symmetric matrix; why this should be is not made clear in taking the path we did. That this will always be so may be deduced from the boxed equation on a previous page, namely

$$v_1^* \cdot S_1 + \phi_1^* \cdot Q_1 + v_2^* \cdot S_2 + \phi_2^* \cdot Q_2 = \int_0^L EI \cdot \frac{d^2 v}{dx^2} \cdot \frac{d^2 v^*}{dx^2} \cdot dx$$

by choosing our arbitrary function $v^*(x)$ to be identical to the prescribed displacement field, $v(x)$. We obtain:

$$v_1 \cdot S_1 + \phi_1 \cdot Q_1 + v_2 \cdot S_2 + \phi_2 \cdot Q_2 = \int_0^L EI \cdot (2a_2 + 6a_3x) \cdot (2a_2 + 6a_3x) \cdot dx$$

Now a_2 and a_3 may be expressed in terms of the prescribed end displacements and rotations via the relationships derived earlier, which, in matrix form, is

$$\begin{bmatrix} a_2 \\ a_3 \end{bmatrix} = \begin{bmatrix} \frac{3}{L^2} & \frac{2}{L} & \frac{3}{L^2} & \frac{2}{L} \\ \frac{2}{L^3} & \frac{1}{L^2} & -\frac{2}{L^3} & \frac{1}{L^2} \end{bmatrix} \begin{bmatrix} v_1 \\ \phi_1 \\ v_2 \\ \phi_2 \end{bmatrix} = [G] \begin{bmatrix} v_1 \\ \phi_1 \\ v_2 \\ \phi_2 \end{bmatrix}$$

Our basic equation then becomes:

$$v_1 \cdot S_1 + \phi_1 \cdot Q_1 + v_2 \cdot S_2 + \phi_2 \cdot Q_2 = EI \int_0^L [v_1 \ \phi_1 \ v_2 \ \phi_2] [G]^T \cdot \begin{bmatrix} 4 & 12x \\ 12x & 36x^2 \end{bmatrix} \cdot [G] \begin{bmatrix} v_1 \\ \phi_1 \\ v_2 \\ \phi_2 \end{bmatrix} dx$$

so the symmetry is apparent.

If you carry through the matrix multiplication and the integration with respect to x you will recover the stiffness matrix for the beam element.

Design Exercise 8.1

Your task is to design a classroom demonstration which shows how the torsional stiffness of a structure depends upon material properties and the geometry of its structural elements.

Your professor has proposed the following as a way to illustrate torsional stiffness and, at the same time, the effects of combined loading on a shaft subjected to bending and torsion. A small number, N , circular rods or tubes are uniformly distributed around and fastened to two relatively rigid, end plates.

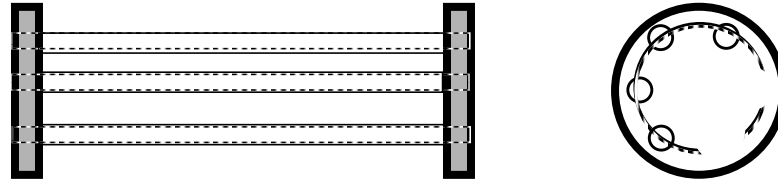

The rods are rigidly fixed to one of the end plates, say the plate at the left shown above. The other ends of the rods are designed so that they can be either free to rotate about their axis or not; that is, the right ends can be fixed rigidly to the plate or they can be left free to rotate about their axis.

If the rods are free to rotate about their axis, then all resistance to rotation of the entire structure is due to the resistance to bending of the N rods. (Note not all N rods are shown in the figure). If, on the other hand, they are rigidly fixed at both ends to the plates, then the torsional stiffness of the overall structure is due to resistance to torsion of the N rods as well as bending.

A preliminary design of this apparatus is needed. In particular:

- The torsional stiffness of the entire structure due to bending of the rods is to be of the same order of magnitude as the torsional stiffness of the entire structure due to torsion of the rods.
- The overall torsional stiffness should be such that the rotation can be made visible to the naked eye for torques whose application does not require excess machinery.
- The apparatus should not fail, yield or break during demonstration.
- It should work with rods of two different materials.
- It should work with hollow tubes as well as solid shafts.
- Attention should be paid to how the ends of the rods are to be fastened to the plates.

Design Exercise 8.2 Back to the Diving Board

Reconsider the design of a diving board where now you are to rely on the elasticity of the board to provide the flexibility and dynamic response you desire. The spring at a will no longer be needed; a roller support will serve instead. In your design you want to consider the stresses due to bending, the static deflection at the end of the board, and its dynamic *feel*.

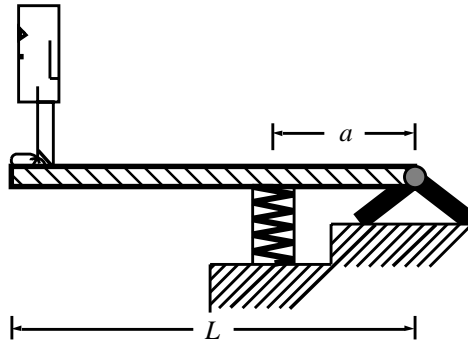

8.5 Problems - Stesses/Deflections, Beams in Bending

8.1 A force P is applied to the end of a cantilever beam but the end also is restrained by a moment M so that it can not rotate, i.e., the slope of the deflected curve is zero at *both* ends of the beam. The end *is* free to deflect vertically a distance Δ . We can write:

$$P = K \Delta$$

The beam is made from a material of Young's modulus E and its (symmetric) cross-section has bending moment of inertia I . Develop an expression for the stiffness K in terms of E , I and L , the length of the beam.

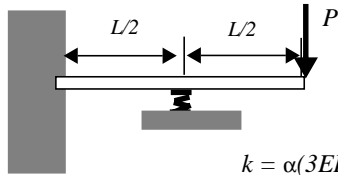
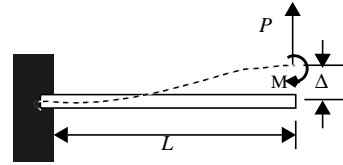

$$k = \alpha(3EI/L^3)$$

- What if α gets very large? How do things change?
- What if α gets very small? How do things change?

8.3 Determine the reactions at the three rollers of the redundantly supported beam which is uniformly loaded.

Sketch the shear force and bending moment distribution.

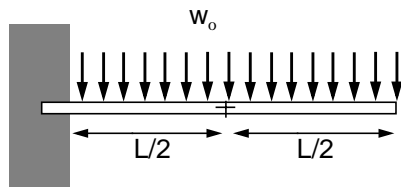
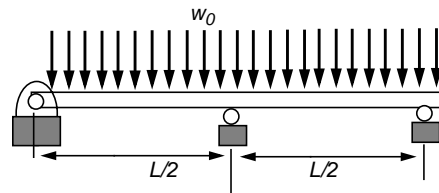

8.4 A cantilever beam carries a uniformly distributed load. Using Matlab, and the derived, beam element stiffness matrix, (2 elements) determine the displacements at midspan and at the free end. Compare with the results of engineering beam analysis provided in the text.

In this, choose a steel beam to support a distributed load of 1000 lb/ft, and let the length be 20 ft.

Run Frameworks with 2, 3, 4 elements and compare your results.

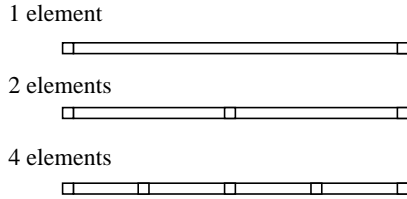
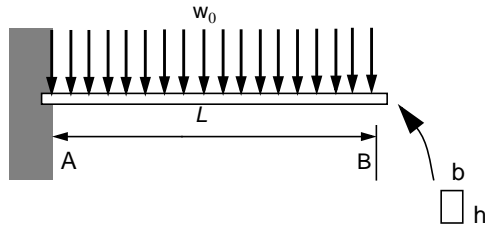

8.5 The cantilever beam AB carries a uniformly distributed load $w_0 = 31.25 \text{ lb/in}$

Its length is $L = 40 \text{ in}$ and its cross section has dimensions

$$b = 1.5 \text{ in} \quad \& \quad h = 2 \text{ in}$$

Take the Elastic Modulus to be that of Aluminum, $E = 10 \text{ E} +06$

a) Show that the tip deflection, according to engineering beam theory is

$$v(L) = -1.0 \text{ in}$$

b) What is the beam deflection at mid-span?

c) Model the beam using Frameworks, in three ways; with 1, 2 and 4 elements. "Lump" the distributed load at the nodes in some rational way. Compare the tip and midspan deflections with that of engineering beam theory.

8.6 Given that the *tip deflection* of a cantilever beam, when loaded *midspan*, is linearly dependent upon the load according to

$$P_m = k_m \delta_m \quad \text{where } k_m = 1000 \text{ N/mm}$$

and given that the *tip deflection* of a cantilever beam, when loaded *at its free end*, is linearly dependent upon the load according to $P_e = k_e \delta_e$ where $k_e = 300 \text{ N/mm}$ and given that the deflection of a spring when loaded is linearly dependent upon the load according to

$$F_s = k_s \delta_s \quad \text{where } k_s = 500 \text{ N/mm}$$

Develop a compatibility condition expressing the tip displacement (with the spring supporting the end of the beam) in terms of the load at mid-span and the force in the spring. Expressing the tip displacement in terms of the force in the spring using the third relationship above, show that

$$F_s = \frac{k_s}{k_m \cdot (1 + k_s/k_e)} \cdot P_m$$

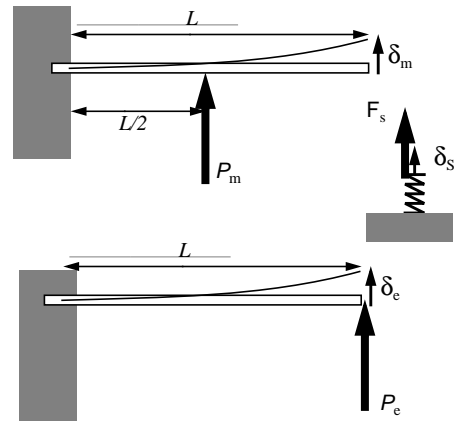

8.7 For the beam subject to "four point bending", determine the expression for the mid-span displacement as a function of P , L and a .

Do the same for the displacement of a point where the load is applied.

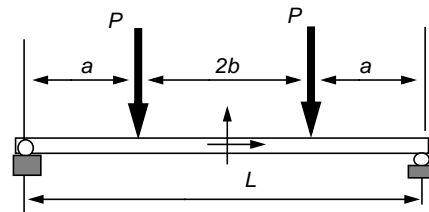

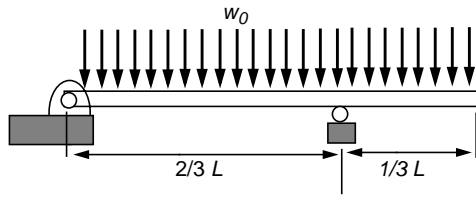

8.8 A beam is pinned at its left end and supported by a roller at $2/3$ the length as shown. The beam carries a uniformly distributed load, w_0 , $\langle F/L \rangle$

Derive the displacement function from the integration of the moment-curvature relationship, applying the appropriate boundary and matching conditions..

8.9 The roller support at the left end of the beam of problem above is replace by a cantilever support - i.e., its end is now fixed - and the roller support on the right is moved out to the end.

Using superpositioning and the displacement functions given in the text :

- i) Determine the reaction at the roller.
- ii) Sketch the bending moment distribution and determine where the maximum bending moment occurs and its value in terms of $w_0 L$
- iii) Where is the displacement a maximum?
Express it in terms of $w_0 L^4/EI$

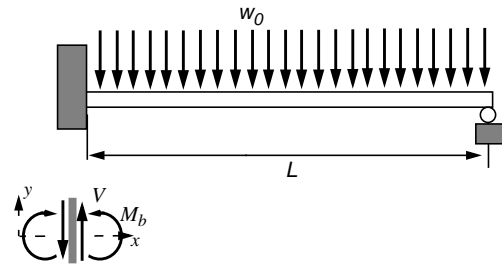

8.10 For small deflections and rotations but with equilibrium taken with resped to the deformed configuration, we derived the following differential equation for the transverse displacement of the end-loaded, "beam-column"

$$\frac{d^4 v}{dx^4} + \lambda^2 \cdot \frac{d^2 v}{dx^2} = 0$$

where

$$\lambda^2 = \frac{P}{EI}$$

$$\text{At } x = -L/2 \text{ and } x = +L/2, \quad v = 0 ; \quad \frac{dv}{dx} = 0$$

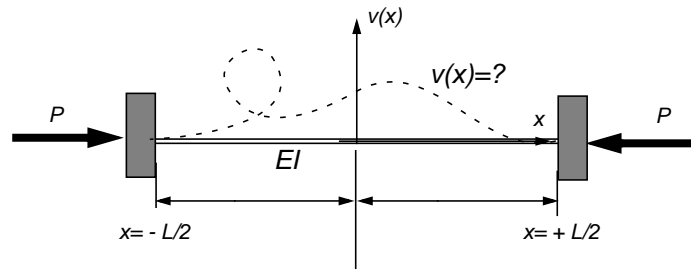

The general solution is: $v(x) = c_1 + c_2 x + c_3 \sin \lambda x + c_4 \cos \lambda x$

Given the boundary conditions above, set up the eigenvalue problem for determining (1) the values of L for which you have a non-trivial solution (the eigenvalues) and (2) the relative magnitudes of the "c" coefficients which define the eigenfunctions.

