

Fivefold symmetric homonuclear dipolar recoupling in rotating solids: Application to double quantum spectroscopy

M. Hohwy,^{a)} C. M. Rienstra, C. P. Jaroniec, and R. G. Griffin^{b)}

Department of Chemistry and Center for Magnetic Resonance, Francis Bitter Magnet Laboratory, Massachusetts Institute of Technology, Cambridge, Massachusetts 02139-4507

(Received 16 November 1998; accepted 21 January 1999)

We describe a new fivefold symmetric approach to homonuclear recoupling in rotating solids that is based on rotor-synchronized, spin-lock rf irradiation of the type employed previously in MELODRAMA and C7 (and their derivative sequences) for ^{13}C - ^{13}C recoupling. The fivefold sequence, like its sevenfold relatives, is γ -encoded, and therefore exhibits a theoretical efficiency of $\sim 73\%$ for double quantum filtering (2QF). However, since the ratio of rf field strength, $\omega_{\text{rf}}/2\pi$, to spinning frequency, $\omega_r/2\pi$, is lower, it is possible to operate the sequence at higher spinning rates, and we have investigated the 2QF efficiency as a function of ^1H decoupling field strength at high spinning frequencies. We observe dramatic oscillations of the recoupled signal with a period $\sim \omega_r/2\pi$ indicating that the ^1H reservoir is behaving partially inhomogeneously. This kind of double quantum recoupling is explored in multiple spin systems and we derive analytical forms for polarization transfer and double quantum excitation relevant for uniformly labeled systems. Finally, the wide applicability of the fivefold sequence is demonstrated with INADEQUATE type spectra of uniformly ^{13}C labeled sucrose and L-alanine. © 1999 American Institute of Physics. [S0021-9606(99)01615-3]

I. INTRODUCTION

A promising area of application of solid state nuclear magnetic resonance (NMR) techniques is the investigation of the molecular structure of biological systems not amenable to solution NMR and diffraction techniques, such as membrane proteins, amyloidogenic proteins, and large macromolecular complexes.¹ The customary approach in these circumstances involves the specific isotopic labeling of the sites of interest with spin-1/2 nuclei possessing low gyromagnetic ratios, γ , (e.g., ^{13}C and ^{15}N), and the measurement of dipole-dipole couplings between both “like” and “unlike” nuclear spins, which provides information about the spatial connectivity and local geometry. Most of the experiments involve a combination of cross-polarization (CP)² and magic angle spinning (MAS)^{3,4} to enhance sensitivity and resolution of the resulting spectra. In addition to removing the chemical shift anisotropy (CSA), MAS attenuates dipolar couplings among low- γ nuclei. Therefore, to obtain structural information from MAS experiments, the homonuclear and/or heteronuclear dipole-dipole interactions must be restored.

To date a number of schemes have been proposed to reintroduce dipolar couplings between low- γ nuclei during MAS, and early approaches are discussed in recent reviews.^{5,6} Here we focus on techniques specifically designed to recouple homonuclear dipole-dipole interactions, such as those between ^{13}C - ^{13}C and ^{15}N - ^{15}N nuclei. Homonuclear dipolar recoupling can be accomplished by manipu-

lating either the MAS frequency or the rf irradiation, and we refer to techniques based on these principles as rotor-driven or rf-driven, respectively. Rotational resonance^{7,8} is an example of the former which specifically recouples spins for which the isotropic chemical shift difference matches an exact submultiple of the spinning frequency.

In addition, rf irradiation can also be used to restore homonuclear dipole-dipole couplings via manipulation of the spin variables in the Hamiltonian. Rf-driven recoupling techniques often rely on the efficient excitation of double quantum coherence (2QC) or zero quantum coherence (ZQC) between two spin-1/2 nuclei, where both 2QC and ZQC are correlated spin states between coupled nuclei.^{9,10} These correlated spin states can be readily selected in NMR experiments by choosing an appropriate phase cycling spinning scheme.^{10,11} It should be noted here that important methods used in the determination of local geometry in biomolecules, such as torsion angle experiments¹²⁻¹⁵ and measurements of the relative orientation of CSA tensors,¹⁶ depend on excitation of double quantum coherence between homonuclear spin pairs. Therefore, techniques that can generate 2QC with high efficiency are expected to play a major role in the application of MAS NMR to problems of biological relevance.

The initial rf-driven recoupling techniques, e.g., DRAMA,^{17,18} DICSY,¹⁹ RFDR,^{20,21} and USEME²² produced a number of interesting spectra, but they are nevertheless sensitive to isotropic chemical shift differences, the size of the CSAs of the recoupled spins, etc. For example, RFDR does not efficiently recouple closely spaced resonances, and DRAMA only recouples closely spaced resonances with vanishing shift anisotropy. Further, during these experiments it was noticed that significant intensity losses occurred when

^{a)}Current address: Laboratory for Biomolecular NMR, Chemistry Department, Univ. of Aarhus, DK-8000 Aarhus C, Denmark.

^{b)}Electronic mail: griffin@ccnmr.mit.edu

the high and low frequency rf fields were not mismatched by a ratio greater than about three,^{21,23,24} a condition initially described by Aue *et al.*²⁵ in connection with chemical shift scaling.

The next generation of recoupling techniques, which included RIL,²⁶ MELODRAMA,²⁷ and DRAWS,²⁸ were designed to correct some of these problems. Thus, RIL and DRAWS exhibit improved bandwidths, and MELODRAMA achieves a large bandwidth with relatively low rf power—four or five times the spinning frequency. However, these techniques also displayed residual error terms in their average Hamiltonians and/or low theoretical efficiency in the sense that approximately 50% of the polarization is lost during the double quantum filtration. An approach to partially circumvent this signal loss was proposed by Lee *et al.*,²⁹ with the C7 pulse sequence, which extended the rotor-synchronized spin-locking scheme of MELODRAMA²⁷ to sevenfold symmetry. The C7 sequence combined the low CSA dependence with a higher theoretical upper bound on the efficiency of double quantum excitation. The improved efficiency of C7 was due to the idea of γ -encoding, first explored in the HORROR experiment,³⁰ where γ in this context is one of the Euler angles relating the crystallite frame to the rotor frame. γ -encoding improves the efficiency of double quantum filtration by making it independent of the γ angle to first order,³⁰ and allows polarization transfer or filtering of double quantum coherence with a theoretical efficiency of up to 73%. Recently, the introduction of C7 type pulse sequences which are compensated for high-order error terms, POST-C7³¹ and CMR7,³² made possible robust and broadband recoupling of the homonuclear dipole–dipole interaction.

The POST-C7 and CMR7 pulse sequences are based on the fundamental sevenfold symmetry proposed by Lee *et al.*,²⁹ which still presents a problem in terms of ^1H decoupling as mentioned above. In particular, experiments based on the C7 symmetry require the rf field on the observe channel (e.g., ^{13}C) to be matched to 7 times the MAS frequency, and therefore, the rf amplitude used for ^1H decoupling should be approximately 21 times the spinning frequency (three times the observe-channel field^{23,24}). While the first condition is relatively easy to satisfy, even at reasonably high spinning frequencies ($\omega_r/2\pi \sim 10$ kHz), the decoupling matching condition is a serious problem which often hinders the realization of the full potential of the sevenfold symmetric techniques. At high magnetic fields and in solids with strong ^1H – ^{13}C couplings, such as most bio-organic molecules, the C7 type sequences often cannot excite double quantum coherence with efficiencies that exceed the 52% theoretical maximum of γ -dependent techniques.³¹

In this paper we demonstrate that the efficiency of double quantum excitation can be improved in γ -encoded homonuclear recoupling techniques by reducing the symmetry of a rotor-synchronized spin-locking pulse sequence from seven- to fivefold. We show that this can be achieved with a phase-inversion supercycle without compromising the CSA compensation. Furthermore, the proper choice of subcycle ensures stability toward isotropic offset and rf-field inhomogeneity comparable to POST-C7 and CMR7. The improved

performance of the new pulse sequence, labeled SPC-5 (Supercycled POST-C5), relies on a lower matching requirement (5 to 1) between the rf field on the observe channel and MAS frequency. Thus, with SPC-5 it is possible to employ higher spinning frequencies ($\omega_r/2\pi \geq 10$ kHz) without concurrent excessive signal loss due to insufficient ^1H decoupling.

To demonstrate that the SPC-5 pulse sequence makes double quantum spectroscopy generally feasible in compounds containing strongly coupled protons and facilitates the studies of bioorganic solids, we have used the sequence to record INADEQUATE type spectra of two uniformly ^{13}C labeled compounds, L-alanine and sucrose. Double quantum coherences were excited with high efficiency between neighboring ^{13}C spins in two different versions of a double quantum–single quantum correlation experiment, which enabled a straightforward assignment of the ^{13}C resonances.

II. THEORY

A. The SPC-5 pulse sequence

The high field truncated Hamiltonian for a general NMR interaction of rank λ in the interaction frame determined by the rf irradiation of a given pulse sequence can in the static case be written as

$$\tilde{H}(t) = \sum_{\mu=-\lambda}^{\lambda} d_{\mu,0}(\theta(t)) e^{-i\mu(\phi(t)+\psi)} T_{\lambda,\mu}, \quad (1)$$

where $\phi(t)$ and $\theta(t)$ depend on the details of the rf irradiation and ψ is an overall phase of the pulse sequence, $d_{\mu,0}(\theta(t))$ is a reduced Wigner element, and $T_{\lambda,\mu}$ is an irreducible tensor operator³³ of rank λ . Consider a C7 type sequence,²⁹ which consists of n periods of rf irradiation which are identical (these subcycles will be referred to as C elements in the following) except for an overall phase shift of $2\pi/n$ between each block of irradiation (i.e., $\psi_p = p2\pi/n$, $p=0,1,\dots,n-1$) and timed to span N rotor periods. The first-order average Hamiltonian of such a sequence can be written as²⁹

$$\tilde{H}^{(1)} = \frac{1}{n} \sum_{p=0}^{n-1} \sum_{\mu,m} \tilde{\omega}_{\lambda,\mu}^{(m)} \exp\left(-i\frac{2\pi}{n}(\mu+mN)p\right) T_{\lambda,\mu}, \quad (2)$$

where

$$\tilde{\omega}_{\lambda,\mu}^{(m)} = \frac{n}{N\tau_r} \int_0^{N\tau_r/n} \omega^{(m)} d_{\mu,0}(\theta(\tau)) e^{-i(\mu\phi(\tau)+m\omega_r\tau)} d\tau, \quad (3)$$

and the Fourier components $\omega^{(m)}$ are defined in Ref. 8. A necessary condition for a given component of the first-order average Hamiltonian characterized by spin and spatial indices μ and m to be nonzero is therefore:

$$\mu + Nm = qn, \quad (4)$$

where q is an integer. However, since Eq. (3) can be zero due to the specific design of the subcycle, Eq. (4) is not a necessary condition.

Consider now two concatenated C7 type cycles with an overall phase shift of Φ . The total average Hamiltonian for each interaction (chemical shift, dipolar coupling, etc.) is then

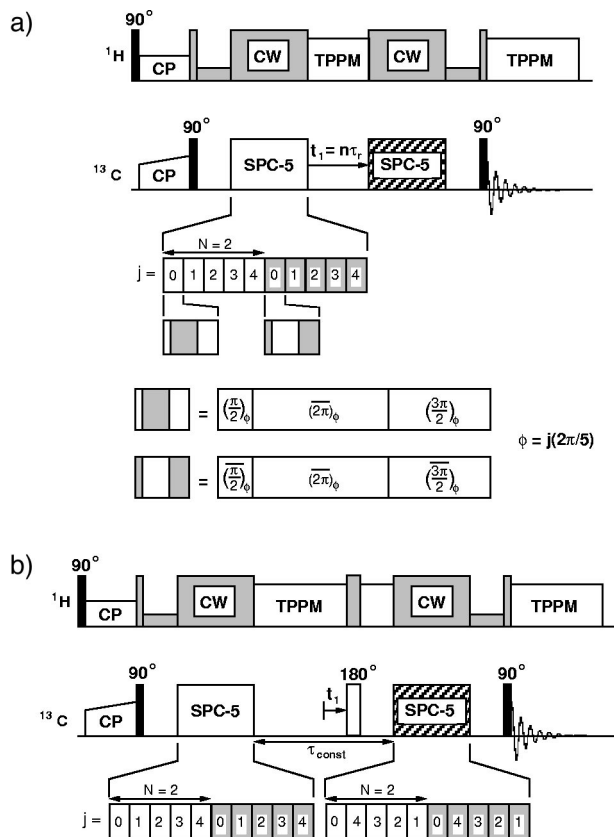

FIG. 1. Two versions, a nonconstant time (a) and constant time (b), of the INADEQUATE experiment employing SPC-5 for 2Q excitation. After ramped CP, longitudinal sum polarization is created by a 90° pulse, which is followed by a z-filter (see the text for details) for one rotor period. Subsequently, the SPC-5 sequence [described in detail in (a)] is initiated, during which the longitudinal polarization of dipolar coupled nuclei evolves into a double quantum state. Isotropic chemical shift evolution during t_1 is followed by a 2Q reversion step. Another z-filter period followed by a 90° pulse creates detectable transverse magnetization. cw decoupling is used during the SPC-5 irradiation, and TPPM decoupling during t_1 evolution and acquisition. The 2Q reversion block in (a) and (b) is hatched to indicate the use of a double quantum phase cycle.

$$\tilde{H}^{(1)} = \frac{1}{2n} \sum_{p=0}^{n-1} \sum_{\mu, m} (1 + e^{-i\mu\Phi}) \tilde{\omega}_{\lambda, \mu}^{(m)} \times \exp\left(-i \frac{2\pi}{n} (\mu + mN)p\right) T_{\lambda, \mu}. \quad (5)$$

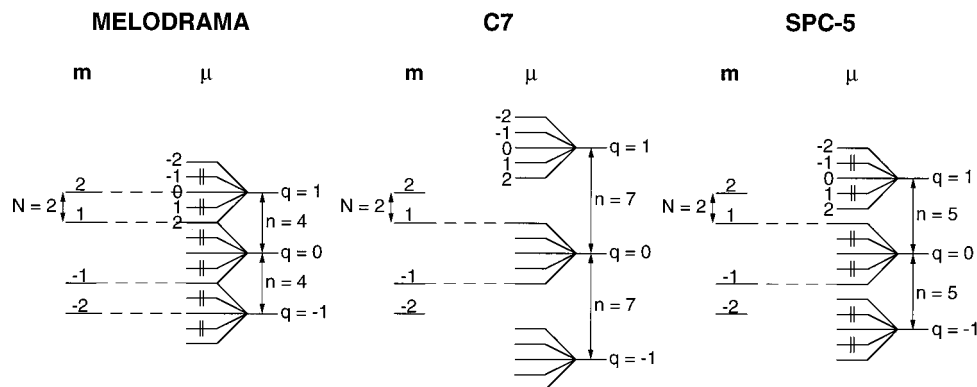

FIG. 2. Symmetry diagrams (similar to the one proposed by Levitt and co-workers—Ref. 34) for MELODRAMA, C7, and SPC-5. The diagrams are a graphical representation of Eq. (4) rearranged as $Nm = -\mu + qn$ to display the components in the first-order average Hamiltonian allowed by the symmetry of the phase super cycle.

By proper choice of the phase angle Φ , this sequence allows more favorable choices of the symmetry numbers N and n , since the phase-inversion supercycle step can be used to filter components of undesired symmetry.

In this work we explore the choice of $\Phi = \pi$ which eliminates all $\mu = \pm 1$ components of the average Hamiltonian. With $\Phi = \pi$ it is possible to obtain γ -encoded recoupling with $n=5$ and $N=2$ and still eliminate all CSA terms. The resulting pulse sequence (SPC-5) is shown in Fig. 1. In Fig. 2, a symmetry diagram similar to the one first suggested by Levitt and co-workers³⁴ is shown for the rotor synchronized spin-locking experiments MELODRAMA, C7, and SPC-5. The diagrams show how the different synchronization conditions employed in these sequences match different pairs of spin and spatial components in the effective Hamiltonian. The dashed lines indicate the components which are symmetry allowed and can be recoupled. Notably, this diagram does not give information about the size of the recoupled components which depends on the actual form of the specific subcycle.

We note the following features on this graphical analysis of the first-order average Hamiltonian: (i) to ensure γ -encoded recoupling, every spin component μ should be connected to only one spatial component m ,^{29,30} (ii) for pure dipolar recoupling without interference from CSA or heteronuclear couplings only $\mu = \pm 2$ spin components should be connected to a spatial component²⁹ unless the given term vanishes through Eq. (3), (iii) the phase inversion supercycle employed in MELODRAMA and SPC-5 filters unwanted $\mu = \pm 1$ components (indicated by vertical lines), (iv) the rf to spinning frequency match is given as sn/N , where s ($s = \omega_{rf}\tau/2\pi$, where τ is the duration of a subcycle and ω_{rf} the field amplitude) is the number of 2π nutations in one subcycle ($s=2$ for C7, POST-C7, CMR7, and SPC-5).

It is clearly seen from Fig. 2 that the MELODRAMA sequence, for which $n=4$, does not fulfill condition (i) and therefore is not γ -encoded (e.g., $\mu=2$ couples to $m=1$ and $m=-1$). Furthermore this choice of symmetry seems to allow recoupling of unwanted longitudinal dipolar and shift terms as noted by Lee *et al.*,²⁹ since these $T_{\lambda,0}$ spin components couple to doubly rotating spatial components (cf. Fig.

2). However consideration of the specific subcycle shows that these terms are actually zero.³²

Increasing n to 7 and omitting the phase inversion supercycle leads to the C7 sequence (cf. Fig. 2) which fulfills (i) and (ii) but poses a problem in terms of decoupling since the n/N ratio (iv) is almost doubled in this case compared to MELODRAMA. One way around this problem is to take advantage of the blocked $\mu=\pm 1$ spin components in the phase inversion approach and setting $n=5$, leading to the SPC-5 sequence (cf. Fig. 2), which satisfies (i) and (ii) with only a moderate increase in the n/N ratio. It is noted that five cycles could also be timed to match three rotor periods, i.e., $N=3$ and $n=5$, leading to a much lower matching condition but at the cost of a lower scaling factor.

The matching of rf field to the spinning frequency depends highly on the choice of the specific subcycle used as the C element. The most economical choice with respect to the rf field would be a simple 2π pulse ($s=1$) corresponding for the SPC-5 sequence to a $\omega_{\text{rf}}/\omega_r$ ratio of 2.5. However, this cycle is very poorly compensated toward error terms and we therefore chose to exploit the possibility to use highly compensated subcycles inherent to this type of sequence. To retain the benefits of high stability toward isotropic shifts, rf inhomogeneity, and CSA, one of the two newly developed compensation schemes should be used: (i) either the POST element,³¹ which averages out important error terms over one cycle or (ii) the CMR7³² supercycling technique which achieves a high degree of compensation over two cycles. To keep the cycle time of the total sequence down we have chosen the POST cycle in this study. It is noted that since the fivefold symmetric sequence uses less rf power at the same spinning frequency compared to the sevenfold symmetric sequences, it is expected that error terms scale up accordingly. For example, the residual fifth-order pure offset term of the POST scheme³¹ scales as $(\omega_0)^5/(\omega_{\text{rf}})^4$. Furthermore, since for the same spinning frequency the CSA terms are averaged over the double time (four rotor periods) compared to the sevenfold symmetric sequences the dependence of CSAs could also be a potential problem. However, numerical simulations and experimental results suggest that neither of these issues imposes a serious limitation on the SPC-5 sequence, particularly when higher MAS rates are used. In fact, simulations indicate that the CSA compensation achieved with SPC-5 is actually better compared to the previous C7 type experiments. The scaling of the dipolar interaction can be calculated using Eq. (6) in Ref. 31 with $n=5$. In the notation of that paper the scaling is

$$|\kappa_5^{143}| \approx 0.203, \quad (6)$$

where the superscript refers to the POST C element and the subscript to the number of subcycles in two rotor periods. For comparison, the scaling of the sevenfold symmetric sequences is ~ 0.232 and it is $3/8\sqrt{2}$ (~ 0.265) for C_∞ (continuous rotation symmetry, i.e., $n \rightarrow \infty$). The condition of continuous rotation symmetry is of course unrealistic, but interestingly, it provides us with an upper bound to the scaling factor for pulse sequences of this kind.

B. Recoupling in multispin systems

The derivation of the SPC-5 sequence given above is strictly limited to the spin-pair approximation. An interesting potential of recoupling methods lies in the application of these methods to uniformly ^{13}C labeled compounds, taking advantage of the high resolution achieved in MAS NMR. Under such circumstances multiple-spin interactions must be considered to correctly predict the experimental results. The analysis can easily be extended to multispin systems since, to first order, no three-spin terms (or higher) will appear in the average Hamiltonian. Hence, for a γ -encoded recoupling sequence, the average Hamiltonian for k coupled spins will be of the form:

$$\tilde{H}_D^{(1)} = \sum_{i>j}^k d_{i,j}(\beta_{ij})(e^{-i(\gamma_{ij}-\chi)}T_{2,2}^{ij} + e^{i(\gamma_{ij}-\chi)}T_{2,-2}^{ij}), \quad (7)$$

where

$$d_{i,j}(\beta_{ij}) = \frac{1}{2} b_{ij} \sin(2\beta_{ij}) \left| \frac{3in^3(1 - \exp\{4i\pi/n\})}{8\sqrt{2}\pi(4n^2 - 1)} \right| \quad (8)$$

and b_{ij} is the dipolar coupling between nuclei i and j , β_{ij} and γ_{ij} are the β and γ Euler angles relating the principal axis system of the i - j dipolar coupling to the rotor fixed frame. The factor within the brackets in Eq. (8) is the *size* and χ [in Eq. (7)] is the *phase* of the scaling factor (the scaling factor is a complex number) of the pulse sequence and n is the symmetry number (5 for SPC-5, and 7 for C7, POST-C7, and CMR7).

As mentioned above this effective Hamiltonian can be used as a polarization-transfer step in homonuclear correlation spectroscopy^{27,32} or as a double quantum generator in filtering experiments,^{29,30} INADEQUATE type experiments,³⁵⁻⁴⁰ and torsion angle experiments.¹²⁻¹⁵ When used for polarization transfer in multispin systems this effective Hamiltonian will lead to magnetization transfer between two noncoupled nuclei if they are dipolar coupled to the same third nucleus (polarization transfer can occur between a spin A and a spin C , if A is dipolar coupled to a third spin B and B to C). In the following we refer to this process as indirect polarization transfer. It was previously observed²⁷ that indirect transfer of this kind would produce cross peaks of sign $(-1)^n$ in correlation spectra, where $n=0,1,2$ is the number of couplings involved in the transfer process, i.e., positive diagonal peak, negative cross peak to directly bonded nuclei, and positive cross peak to indirectly coupled nuclei. This can be explained⁴¹ by deriving polarization transfer functions p for a three-spin system, i.e., evaluating the function:

$$p_j(\tau) = \text{Tr}\{\exp(-i\tilde{H}_D^{(1)}\tau)I_z^1 \exp(i\tilde{H}_D^{(1)}\tau)I_z^j\}, \quad j=1,2,3, \quad (9)$$

where $p_j(\tau)$ is the amount of longitudinal polarization on spin j at time τ . The effective Hamiltonian in Eq. (7) can be factored in the following way:

$$\tilde{H}_D^{(1)}(\beta, \gamma) = e^{-i\gamma\tilde{H}_D^{(1)}(\beta, 0)}e^{i\gamma}, \quad (10)$$

with

$$I_{z\gamma} = \sum_{i=1}^3 c_i I_z^i, \quad c_i = \frac{1}{2}(\gamma_{ij} + \gamma_{ki} - \gamma_{jk} - \chi), \quad j, k \neq i. \quad (11)$$

By inserting Eq. (10) in Eq. (9) and using the invariance of the trace to cyclic permutation of the matrix product it can be shown that $p_j(\tau)$ is independent of γ_{ij} and χ . Analytical diagonalization of the remaining, real, effective Hamiltonian leads to

$$p_1(\tau) = r^{-4}(\beta^2 + (\alpha^2 + \gamma^2)\cos[rt])^2, \quad (12)$$

$$p_2(\tau) = -2r^{-4}(\alpha^4 - \beta^2\gamma^2 + \alpha^2(\beta^2 + \gamma^2) + (\alpha^2 + \beta^2) \times (\alpha^2 + \gamma^2)\cos[rt])\sin^2[\frac{1}{2}rt], \quad (13)$$

$$p_3(\tau) = -2r^{-4}(\gamma^4 - \beta^2\alpha^2 + \gamma^2(\beta^2 + \alpha^2) + (\gamma^2 + \beta^2) \times (\alpha^2 + \gamma^2)\cos[rt])\sin^2[\frac{1}{2}rt], \quad (14)$$

where

$$r = \sqrt{\alpha^2 + \beta^2 + \gamma^2}, \quad (15)$$

and $\alpha = b_{AB}$, $\beta = b_{BC}$, $\gamma = b_{AC}$ are the three possible couplings in a three-spin system.

For the typical situation $\alpha \sim \beta \gg \gamma$, γ can be neglected and Eqs. (13) and (14) will have different signs and hence give rise to cross peaks of different sign (cf. Fig. 3). This effect was recently exploited to facilitate assignment in the two-dimensional homonuclear correlation spectrum of erythromycin-A.³² Furthermore, it is seen from these equations that polarization transfer processes using this kind of recoupling sequence in uniformly labeled systems will be governed only by the direct (strong) couplings⁴¹ since the coupling constants appear as square sums in Eqs. (12)–(14). A similar effect can be expected in INADEQUATE type spectra using a recoupling technique such as SPC-5 since double quantum coherence excited between *A* and *B* will be partly reconverted to coherence on the *C* spin if *B* and *C* are coupled. This provides an indirect correlation of *A* to *C*. The intensities of the peaks at the shifts for spin *A*, *B*, and *C* in the slice corresponding to the sum chemical shift of *A* and *B* in an INADEQUATE type spectrum are given by

$$p_j(\tau) = \text{Tr}[e^{i\tilde{H}_D^{(1)}\tau} \hat{F}_{AB}^{2Q} \{e^{-i\tilde{H}_D^{(1)}\tau} I_z e^{i\tilde{H}_D^{(1)}\tau}\} e^{-i\tilde{H}_D^{(1)}\tau} I_z^j], \quad j = 1, 2, 3, \quad (16)$$

where $\hat{F}_{AB}^{2Q} = |I_+^A I_+^B\rangle\langle I_+^A I_+^B| + |I_-^A I_-^B\rangle\langle I_-^A I_-^B|$ is the projection superoperator corresponding to filtration of double quantum coherence between the *AB* spin pair. Equation (16) can be evaluated along the same lines as Eqs. (12)–(14), leaving out the complex phase factor in the effective dipolar Hamiltonian, leading to the results:

$$p_1(\tau) = -32r^{-4}((\alpha^2 + \beta^2)\gamma^2 \cos^2[\frac{1}{2}rt]\cos[rt]\sin^4[\frac{1}{2}rt]), \quad (17)$$

$$p_2(\tau) = 4r^{-4}(\gamma^2 \cos[rt](\beta^2 + (\alpha^2 + \gamma^2)\cos[rt])\sin^2[rt]), \quad (18)$$

$$p_3(\tau) = 4r^{-4}(\gamma^2 \cos[rt](\alpha^2 + (\beta^2 + \gamma^2)\cos[rt])\sin^2[rt]). \quad (19)$$

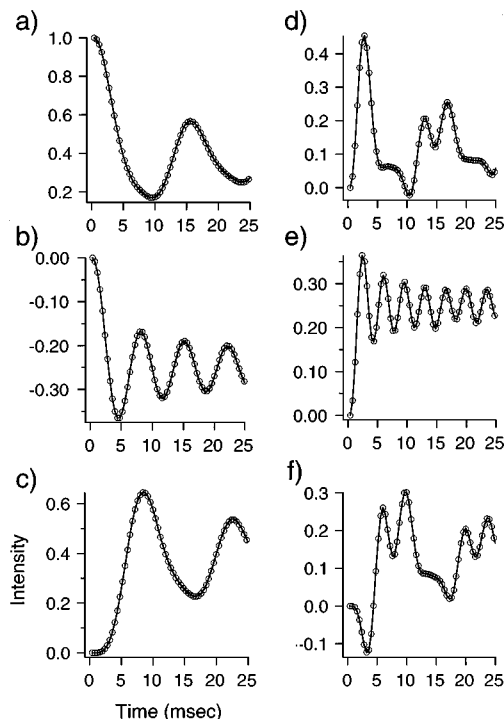

FIG. 3. Polarization transfer functions (a)–(c) for a three-spin system (*ABC*) calculated using Eqs. (12)–(14) (circles) and numerically exact calculations (lines). Intensities (d)–(f) for the same resonances in the *AB* slice through the indirect dimension of an INADEQUATE type experiment using Eqs. (17)–(19) (circles) and numerical calculations (lines). A linear topology was chosen for the spin system, i.e., $\beta_{AB} = \beta_{BC} = \beta_{AC}$, with $b_{AB} = b_{BC} = 500.0$ Hz and $b_{AC} = 0$. Qualitatively, other topologies display the same behavior.

Again, we see that the spin dynamics will be determined by the strong couplings and we expect a change of sign in the indirectly correlated peak. In Fig. 3 we compare the analytical solutions in Eqs. (12)–(14) and Eqs. (17)–(19) to results from numerically exact calculations for a three-spin system.

Besides providing fundamental analytical insight into the spin dynamics of many-body problems, we expect that such analytical forms may be useful for the processing of multi-dimensional experiments employing SPC-5 recoupling (or C7 type recoupling) in combination with ¹³C–¹H or ¹³C–¹⁵N dephasing periods to extract torsion angles.

III. EXPERIMENT

Uniformly ¹³C labeled diammonium oxalate (DAOX), L-alanine, sucrose, and [1,2-¹³C, ¹⁵N]glycine were obtained from Cambridge Isotope Laboratories (Andover, MA). DAOX, L-alanine and sucrose were diluted to 10%, 10%, and 20%, respectively, in natural abundance materials to attenuate intermolecular ¹³C–¹³C couplings and model the conditions of a macromolecule. All samples were center packed in 4 or 5 mm zirconia rotors from Chemagnetics (Fort Collins, CO) to maximize the rf homogeneity across the sample.

NMR experiments were performed at several magnetic field strengths using custom-designed spectrometers and data acquisition and processing software courtesy of Dr. D. J. Ruben. In all experiments the spinning frequency was regulated using Doty Scientific (Columbia, SC) spin rate control-

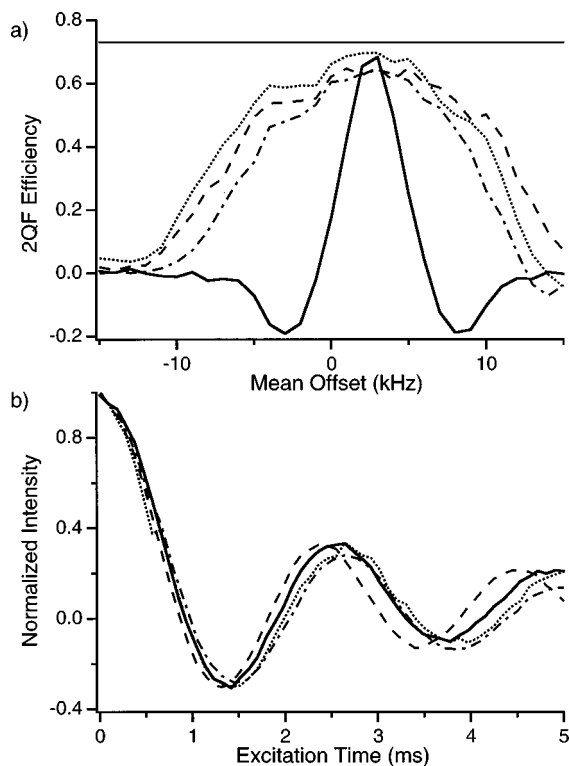

FIG. 4. (a) Experimental double quantum filtering efficiencies for the ^{13}C - ^{13}C spin pair in $[1,2-^{13}\text{C}]$ DAOX as a function of mean offset for C7 (solid line), POST-C7 (dotted line), CMR7 (dashed line), and SPC-5 (dot dashed line). A double quantum excitation time of 0.672 ms was used. (b) Sum polarization (see the text) as a function of excitation time for the same four recoupling sequences. Experiments were performed at 198.8 MHz ^1H frequency and 5.952 kHz (± 5 Hz) MAS rate. 150 kHz cw decoupling was used during the 2Q excitation and reconversion periods and the FID was acquired using 100 kHz TPPM decoupling. The horizontal solid line indicates the $\sim 73\%$ theoretical maximum of 2Q filtering efficiency attainable using γ -encoded recoupling techniques.

lers. The spinning frequency was controlled to ± 5 Hz for spinning in the 5–8 kHz range and to ± 15 Hz for 15 kHz spinning.

The curves in Fig. 4 were recorded on a spectrometer operating at Larmor frequencies of 198.8 MHz for ^1H and 50.0 MHz for ^{13}C . A custom-designed triple resonance transmission-line probe (250–300 kHz maximum decoupling field) was used, equipped with a Chemagnetics 5 mm spinning module assembly.

The data in Figs. 5 and 6, illustrating the efficiency of double quantum excitations as a function of heteronuclear decoupling field for SPC-5, POST-C7, and CMR7, were acquired at ^1H frequency of 360.3 MHz (90.6 MHz ^{13}C). A commercial Chemagnetics probe that provided maximum decoupling fields of approximately 130 kHz and equipped with a 4 mm spinning module assembly was used. Experiments were performed at spinning frequencies in the range of 5.556–15.151 kHz, corresponding to ^{13}C fields from 27.8 to 75.8 kHz, as required by the SPC-5 pulse sequence.

INADEQUATE type experiments on uniformly ^{13}C labeled L-alanine and sucrose (Figs. 7 and 8) were performed using a spectrometer operating at ^1H and ^{13}C frequencies of 397.8 and 100.0 MHz, respectively. The custom-designed triple resonance transmission-line probe used, was equipped

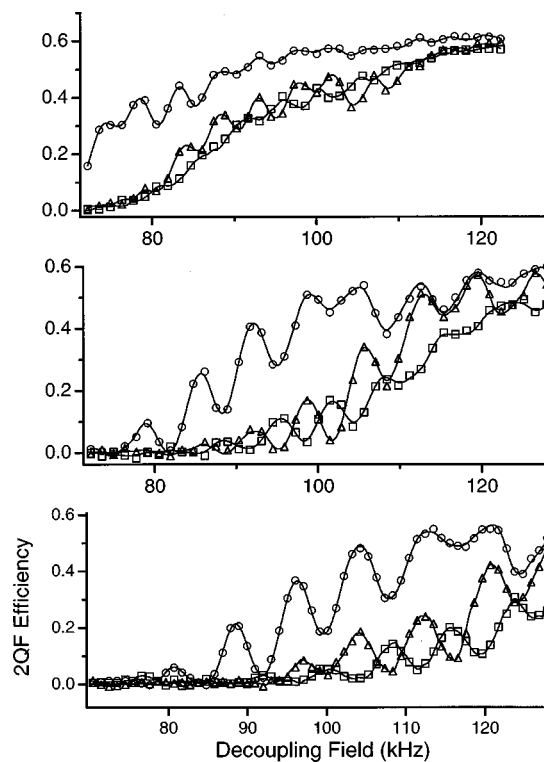

FIG. 5. Double quantum filtering efficiencies for $[1,2-^{13}\text{C}, ^{15}\text{N}]$ glycine as a function of the rf amplitude used for cw ^1H decoupling at 5.556 (a), 8.000 kHz (b), and 10.000 kHz (c), for SPC-5 (circles), CMR7 (squares), and POST-C7 (triangles). The double quantum excitation times were 0.720, 0.750, and 0.800 ms, respectively. Experiments were performed at 360.3 MHz ^1H frequency and 83 kHz TPPM decoupling was used during acquisition. The number of points shown in the graphs was reduced for clarity.

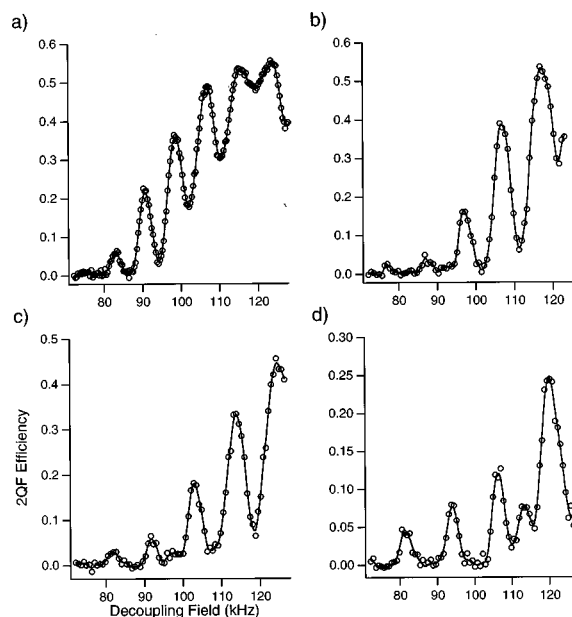

FIG. 6. 2QF efficiencies as a function of ^1H decoupling power for different MAS rates: (a) 10.000, (b) 12.048, (c) 12.987, and (d) 15.151 kHz. The double quantum excitation times were 0.800, 0.664, 0.616, and 0.528 ms, respectively. Other experimental parameters were set as described in caption of Fig. 5.

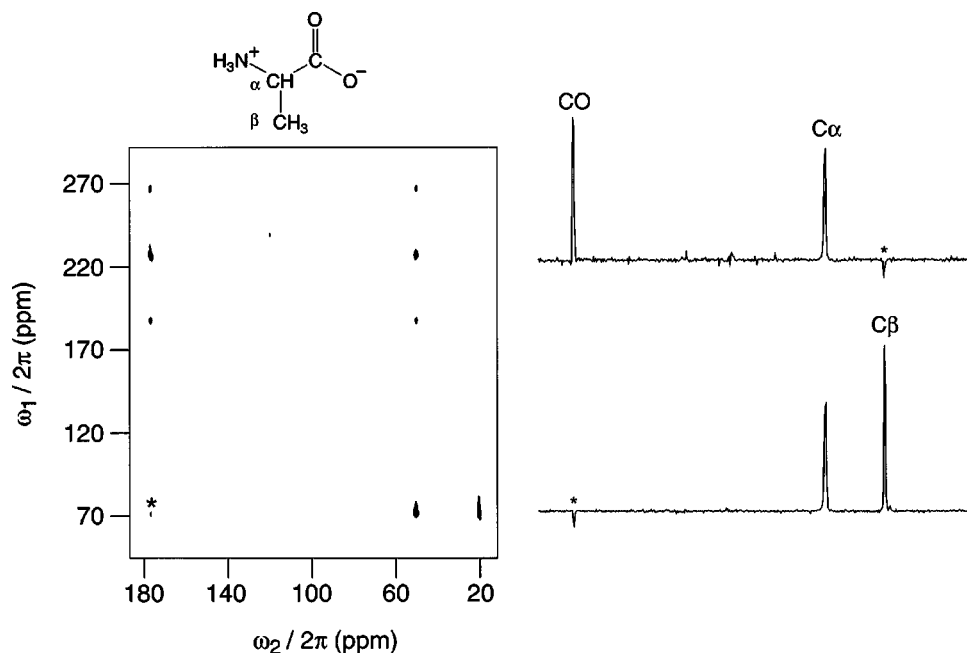

FIG. 7. Constant-time INADEQUATE type spectrum of $[U-^{13}\text{C}]$ L-alanine, which correlates the double and single quantum frequencies of each peak using SPC-5 as the 2Q generator. The asterisk marks a negative cross peak arising from indirect coherence transfer (see the text for details). The spectrum was acquired at 397.8 MHz ^1H frequency and 8.000 kHz MAS, with 0.500 ms double quantum excitation time. 122 kHz cw ^1H decoupling was applied during the SPC-5 sequence and 83 kHz TPPM ^1H decoupling during the t_1 evolution and acquisition.

with a 4 mm Chemagnetics spinner module, and provided maximum decoupling fields of about 125 kHz. Spinning frequency was controlled at 8.000 kHz. The recycle delays were 3.0 and 60.0 s for L-alanine and sucrose, respectively.

The pulse sequence used to excite double quantum coherences between ^{13}C nuclei is shown in Fig. 1(a). Ramped cross polarization⁴² was used to transfer magnetization from ^1H to ^{13}C nuclei (typical fields 30–40 kHz; contact time 1–2 ms). This was followed by a 90° pulse, which creates longitudinal polarization on the ^{13}C spins. Subsequently, low-power cw ^1H decoupling was applied for one rotor period, which allows unwanted transverse magnetization to dephase

(z -filter). The longitudinal polarization of dipolar coupled ^{13}C spin pairs evolves into a double quantum state during the period of recoupling rf irradiation (SPC-5). Isotropic chemical shift evolution takes place during t_1 which is followed by a period of SPC-5 irradiation to reconvert the 2Q coherence into longitudinal polarization. Another z -filter followed by a 90° pulse creates detectable transverse magnetization. TPPM decoupling⁴³ is used during the acquisition of the FID.

The pulse sequences used to obtain INADEQUATE type spectra of sucrose and L-alanine are shown in Figs. 1(a) and 1(b), respectively. These sequences demonstrate two different approaches toward performing double quantum–single

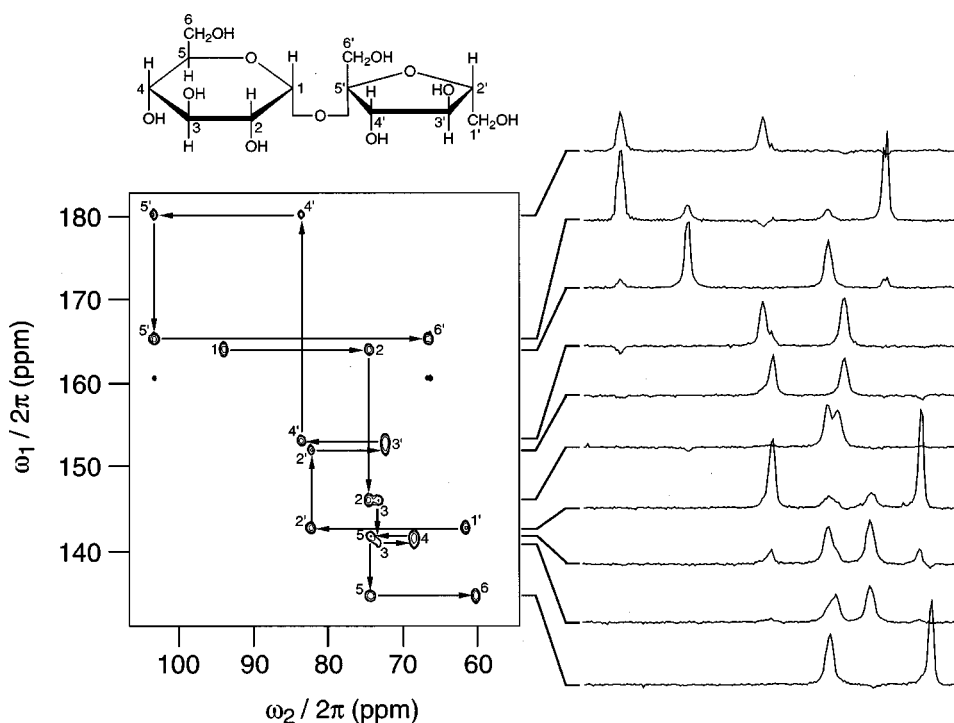

FIG. 8. INADEQUATE type spectrum of $[U-^{13}\text{C}]$ sucrose, which correlates the double and single quantum frequencies of each peak using SPC-5 as the 2Q generator. The indirect dimension, t_1 , was incremented in integral rotor periods, providing a suitable spectral width of the double quantum dimension. Other experimental parameters were set as described in the caption of Fig. 7.

quantum correlation spectroscopy in rotating solids (*vide infra*).

IV. DISCUSSION

At low static field (200 MHz ^1H frequency) the decoupling power available to us (250–300 kHz) is sufficient to decouple the strong ^1H – ^{13}C interactions while recoupling ^{13}C – ^{13}C homonuclear couplings using C7 type sequences. In this regime of sufficient decoupling we observe behavior in very close agreement with a two-spin model. In Fig. 4 we show such results obtained at 200 MHz ^1H frequency. Figure 4(a) displays the 2QF efficiency for C7, POST-C7, CMR7, and SPC-5 as a function of mean offset for 1,2- ^{13}C labeled diammonium oxalate (DAOX). The narrow band performance of the C7 sequence is due to residual offset terms and cross terms between offset and rf inhomogeneity as demonstrated in other studies.^{31,32} It is seen that the compensation scheme used for the SPC-5 sequence works quite well even with the lower power used for this sequence (5/7 of the sevenfold symmetric sequences). Figure 4(b) displays the observable $\langle I_z + S_z \rangle$ as a function of excitation time. As predicted from the scaling factor, SPC-5 displays the slowest oscillation. However, it is also noted, that there is a significant spread in the oscillation frequencies of the sevenfold symmetric sequences, which have identical dipolar scaling factors to first order.

At higher magnetic field strength the proton–carbon heteronuclear couplings become exceedingly more difficult to decouple. Partly because the available decoupling fields are lower, but even at the same decoupling fields the signal loss is greater at higher magnetic fields. We ascribe this effect to the increased proton CSAs in combination with the low offset tolerance of cw decoupling.⁴³ Figure 5 shows typical results on a 360 MHz ^1H frequency spectrometer. The curves display the 2QF efficiency as a function of the decoupling power at 5.556, 8.000, and 10.000 kHz spinning, respectively. At these spinning frequencies the SPC-5 sequence uses a carbon rf field of 27.8, 40.0, and 50.0 kHz, respectively. The corresponding numbers for the sevenfold symmetric sequences are 38.9, 56.0, and 70.0 kHz. The general picture for low spinning frequencies [cf. Fig. 5(a)] is that virtually no double quantum excitation is obtained at decoupling powers less than twice the carbon rf field. Above this condition the efficiency rises steeply until a three-to-one mismatch between the decoupling and observe fields is satisfied. At this point the slope of the curves decreases, but even at this level of decoupling the curves continue to rise, suggesting that the decoupling remains insufficient. At higher spinning frequencies (and higher observe channel rf field) two complicating observations were made: (i) The weak oscillations observed at low spinning frequencies develop into significant maxima superimposed on the sigmoidal curve observed at lower MAS frequencies. The spacing of these maxima approximately equals the spinning frequency and clearly indicates that the MAS plays an important role in averaging residual dipolar couplings at high spinning frequencies. (ii) The decoupling curve shifts down at higher MAS frequencies (higher observe fields) so that 2Q coherences can be excited even at decoupling fields lower than

two times the observe field. At 8.000 kHz [cf. Fig. 5(b)] this is particularly true for the sevenfold symmetric sequences. However, the same effect is observed for SPC-5 at higher spinning frequencies and at 12 kHz MAS (60 kHz observe field) and ~ 120 kHz cw decoupling (see Fig. 6) we observed about 55% 2QF efficiency for SPC-5. This seems to indicate that the absolute field strength as well as the mismatch ratio of the decoupling and observe fields in addition to the MAS frequency determine the signal loss due to strongly coupled protons. A more detailed analysis of the decoupling dynamics will be presented elsewhere.

As expected, the greater mismatch of the decoupling and observe fields in the case of SPC-5 makes the slope of the corresponding curves steeper and shifted down to lower decoupling fields. In practice this means that higher 2QF efficiency can be obtained at lower decoupling levels. In this study (Fig. 5) a commercial probe from Chemagnetics was used and we were limited to decoupling fields ≤ 130 kHz. In this typical situation the SPC-5 sequence generally gave higher 2QF efficiencies than the sevenfold symmetric sequences. This was particularly true at high spinning frequencies. At 12–13 kHz MAS $>50\%$ 2QF efficiency was obtained using SPC-5 whereas the C7 type sequences were not feasible under these conditions due to limitations in the observe channel rf field.

INADEQUATE type spectroscopy^{35–40} in which the sum chemical shift of two coupled nuclei is correlated with each of the isotropic shifts offers the advantage compared to 1Q correlation spectroscopy of not producing diagonal peaks and therefore potentially slightly better resolution. Furthermore, the J coupling between resonances supporting the double quantum coherence will not be active in the t_1 period and one of the line broadening mechanisms in uniformly labeled systems will thus be reduced relative to the spectral range. Preferably, such experiments should be carried out at high magnetic field for optimum sensitivity and resolution. In this case it is desirable to conduct the experiment under reasonably high frequency MAS to avoid dispersion of the intensity of the signal into spinning sidebands due to CSAs. As discussed above, strong heteronuclear ^{13}C – ^1H couplings will compromise the performance of recoupling techniques which use high rf fields on the observe channel. In this case, the lower rf requirements of the SPC-5 sequence make it a good choice as the double quantum generator. As a demonstration, INADEQUATE type spectra using SPC-5 (see Fig. 1), correlating 2Q and 1Q frequencies of uniformly ^{13}C labeled L-alanine and sucrose are shown in Figs. 7 and 8, respectively.

The INADEQUATE type spectrum of L-alanine shown in Fig. 7 was performed in a *constant-time* fashion [Fig. 1(b)], i.e., the delay between the double quantum excitation and reconversion blocks, labeled as solid-white and hatched, respectively, in Fig. 1, remains constant throughout the experiment. A period, τ , equal to an even number of rotor cycles, is inserted between the double quantum excitation and reconversion blocks. At $t_1=0$, a single 180° pulse is placed with its center precisely at $\tau/2$ following the excitation block. The indirect dimension, t_1 , is incremented in 50 μs steps, as the 180° pulse is moved toward the reconversion

block. This gives rise to an evolution period of the sum chemical shift of the two resonances supporting the double quantum coherence. The J coupling between these two spins will not affect the double quantum coherence, whereas J couplings to extraneous spins will. However, since the homonuclear ^{13}C - ^{13}C isotropic J couplings are invariant to the π pulse, the J interaction will not evolve as a function of t_1 but it will result in an overall decay of the signal. Note that due to the presence of an odd number of 180° pulses between the double quantum excitation and reconversion blocks, the non-orthogonal phase shifts of the SPC-5 sequence in the reconversion block must be performed in reverse compared to the excitation sequence. This changes the sign of the γ angle in the phase factor of the γ angle in the phase factor of the effective Hamiltonian [cf. Eq. (7)] and therefore takes into account the 180° pulse which has a similar effect on the double quantum coherence.⁴⁴ For this experiment, the spectral width can be chosen independently of the spinning frequency.

The spectrum displays the expected $\text{CO}-\text{C}_\alpha$ and $\text{C}_\beta-\text{C}_\alpha$ correlations. We note that the spinning sideband manifold in the indirect dimension for the CO and C_α are identical since they are determined by the sum CSAs of the two spins.¹⁶ As predicted in Sec. II, we also observe a small negative peak (marked with an asterisk), correlating the double quantum coherence of $\text{C}_\beta-\text{C}_\alpha$ to the isotropic shift of CO leading to an indirect correlation analogous to what has previously been observed in single quantum correlation spectroscopy.^{27,32} As in the single quantum case this is a very useful feature of the spectrum which can help the assignment of resonances in more complicated spectra.

An example of a more crowded spectrum is provided by the sucrose INADEQUATE type spectrum shown in Fig. 8. In this experiment, the double quantum reconversion block immediately follows the excitation block for $t_1 = 0$ [see Fig. 1(a)], and t_1 is incremented in multiples of the rotor period. Phase sensitive detection in the t_1 dimension⁴⁵ was achieved by acquiring two separate data sets with the overall phase shift of 0° and 45° on the 2Q reconversion sequence (hatched). The t_1 evolution was rotor synchronized so that only isotropic shift and homonuclear J coupling interactions (except those acting between the spin pairs which support the double quantum coherence) will influence the spin dynamics in this dimension. This assumes that the influence from ^{13}C - ^{13}C dipolar couplings is negligible at this spinning frequency. ^{31}P spectra obtained using similar pulse sequences (using C7 instead of SPC-5 as the 2Q generator) of compounds without interference from strong ^1H couplings have previously been presented.³⁸⁻⁴⁰

V. CONCLUSIONS

In conclusion, we have presented a new γ -encoded recoupling sequence that is less demanding in terms of decoupling which allows higher spinning frequencies than the C7 type sequences. This was achieved by redesigning the symmetry of the recoupling scheme so as to allow a more favorable choice of the rf matching condition. As demonstrated, this may at some decoupling fields lead to significantly increased double quantum filtering efficiency. The sequence

was shown to perform well with a variety of samples, on home-built transmission line probes as well as on a commercial probe with a more modest Q factor. Due to the combination of high double quantum efficiency through γ -encoded recoupling and the possibility to spin fast, we expect that this sequence will find use as a double quantum generator in torsion angle experiments and other experiments aimed at solving the structure of biologically relevant molecules, where an optimum signal to noise ratio is crucial.

ACKNOWLEDGMENTS

This research was supported by NIH Grant No. GM-23403 and RR-00995. C.M.R. was a Howard Hughes Medical Institute Predoctoral Fellow and C.P.J. is a recipient of a NSF Predoctoral Fellowship.

- ¹R. G. Griffin, *Nature Struct. Biol.* **5**, 508 (1998).
- ²A. Pines, M. G. Gibby, and J. S. Waugh, *J. Chem. Phys.* **59**, 569 (1973).
- ³E. R. Andrew, A. Bradbury, and R. G. Eades, *Nature (London)* **182**, 1659 (1958).
- ⁴I. J. Lowe, *Phys. Rev. Lett.* **2**, 285 (1959).
- ⁵J. M. Griffiths and R. G. Griffin, *Anal. Chim. Acta* **283**, 1081 (1993).
- ⁶A. E. Bennett, R. G. Griffin, and S. Vega, *NMR Basic Principles and Progress* **33**, 1 (1994).
- ⁷D. P. Raleigh, M. H. Levitt, and R. G. Griffin, *Chem. Phys. Lett.* **146**, 71 (1988).
- ⁸M. H. Levitt, D. P. Raleigh, F. Cruzet, and R. G. Griffin, *J. Chem. Phys.* **92**, 6347 (1990).
- ⁹M. Munowitz, *Coherence and NMR* (Wiley, New York, 1988).
- ¹⁰R. R. Ernst, G. Bodenhausen, and A. Wokaun, *Principles of Nuclear Magnetic Resonance in One and Two Dimensions* (Clarendon, Oxford, 1987).
- ¹¹A. Wokaun and R. R. Ernst, *Chem. Phys. Lett.* **52**, 407 (1977).
- ¹²X. Feng, Y. K. Lee, D. Sandstrom, M. Eden, H. Maisel, A. Sebald, and M. H. Levitt, *Chem. Phys. Lett.* **257**, 314 (1996).
- ¹³X. Feng *et al.*, *J. Am. Chem. Soc.* **119**, 6853 (1997).
- ¹⁴M. Hong, J. D. Gross, and R. G. Griffin, *J. Phys. Chem. B* **101**, 5869 (1997).
- ¹⁵P. R. Costa, J. D. Gross, M. Hong, and R. G. Griffin, *Chem. Phys. Lett.* **280**, 95 (1997).
- ¹⁶D. M. Gregory, M. A. Mehta, J. C. Shiels, and G. P. Drobny, *J. Chem. Phys.* **107**, 28 (1997).
- ¹⁷R. Tycko and G. Dabbagh, *Chem. Phys. Lett.* **173**, 461 (1990).
- ¹⁸R. Tycko and S. O. Smith, *J. Chem. Phys.* **98**, 932 (1993).
- ¹⁹J. H. Ok, R. G. S. Spencer, A. E. Bennett, and R. G. Griffin, *Chem. Phys. Lett.* **197**, 389 (1992).
- ²⁰A. E. Bennett, J. H. Ok, R. G. Griffin, and S. Vega, *J. Chem. Phys.* **96**, 8624 (1992).
- ²¹A. E. Bennett, C. M. Rienstra, J. M. Griffiths, W. Zhen, P. T. Lansbury, Jr., and R. G. Griffin, *J. Chem. Phys.* **108**, 9463 (1998).
- ²²T. Fujiwara, A. Ramamoorthy, K. Nagayama, K. Hoika, and T. Fujito, *Chem. Phys. Lett.* **212**, 81 (1993).
- ²³Y. Ishii, J. Ashida, and T. Terao, *Chem. Phys. Lett.* **246**, 439 (1995).
- ²⁴A. E. Bennett, Ph.D. thesis, Massachusetts Institute of Technology, 1995.
- ²⁵W. P. Aue, D. J. Ruben, and R. G. Griffin, *J. Chem. Phys.* **80**, 1729 (1984).
- ²⁶M. Baldus, M. Tomaselli, B. H. Meier, and R. R. Ernst, *Chem. Phys. Lett.* **230**, 329 (1994).
- ²⁷B.-Q. Sun, P. R. Costa, D. Kocisko, P. T. Lansbury, Jr., and R. G. Griffin, *J. Chem. Phys.* **102**, 702 (1995).
- ²⁸D. M. Gregory, D. J. Mitchell, J. A. Stringer, S. Kiihne, J. C. Shiels, J. Callahan, M. A. Mehta, and G. P. Drobny, *Chem. Phys. Lett.* **246**, 654 (1995).
- ²⁹Y. K. Lee, N. D. Kurur, M. Helmle, O. Johannessen, N. C. Nielsen, and M. H. Levitt, *Chem. Phys. Lett.* **242**, 304 (1995).
- ³⁰N. C. Nielsen, H. J. Jakobsen, H. Bildsøe, and M. H. Levitt, *J. Chem. Phys.* **101**, 1805 (1994).
- ³¹M. Hohwy, H. J. Jakobsen, M. Edén, M. H. Levitt, and N. C. Nielsen, *J. Chem. Phys.* **108**, 2686 (1998).

- ³²C. M. Rienstra, M. E. Hatcher, L. J. Mueller, B.-Q. Sun, S. W. Fesik, J. Herzfeld, and R. G. Griffin, *J. Am. Chem. Soc.* **120**, 10602 (1998).
- ³³M. Mehring, *Principles of High Resolution NMR in Solids*, 2nd ed. (Springer, Berlin, 1983).
- ³⁴X. Feng, M. Edén, A. Brinkmann, H. Luthman, L. Eriksson, A. Gräslund, O. N. Antzutkin, and M. H. Levitt, Direct Determination of a Peptide Torsional Angle Psi by Double-Quantum Solid-State NMR, 39th Experimental NMR Conference, Asilomar, CA, 1998 (unpublished).
- ³⁵A. Bax, R. Freeman, and S. P. Kempell, *J. Am. Chem. Soc.* **55**, 4849 (1980).
- ³⁶E. M. Menger, S. Vega, and R. G. Griffin, *J. Am. Chem. Soc.* **108**, 2215 (1986).
- ³⁷A. Lesage, C. Auger, S. Caldarelli, and L. Emsley, *J. Am. Chem. Soc.* **119**, 7867 (1997).
- ³⁸H. Geen, J. J. Titman, J. Gottwald, and H. W. Spiess, *Chem. Phys. Lett.* **227**, 79 (1994).
- ³⁹M. Feike, R. Graf, I. Schnell, C. Jager, and H. W. Spiess, *J. Am. Chem. Soc.* **118**, 9631 (1996).
- ⁴⁰W. A. Dollase, M. Feike, H. Forster, T. Schaller, I. Schnell, A. Sebald, and S. Steuernagel, *J. Am. Chem. Soc.* **119**, 3807 (1997).
- ⁴¹P. R. Costa, Ph.D. thesis, Massachusetts Institute of Technology, 1996.
- ⁴²G. Metz, X. Wu, and S. O. Smith, *J. Magn. Reson., Ser. A* **110**, 283 (1994); S. Zhang, C. L. Czekaj, and W. T. Ford, *ibid.* **111**, 1805 (1994).
- ⁴³A. E. Bennett, C. M. Rienstra, M. Auger, K. V. Lakshmi, and R. G. Griffin, *J. Chem. Phys.* **103**, 6951 (1995).
- ⁴⁴M. H. Levitt (private communication).
- ⁴⁵D. J. States, R. A. Haberkorn, and D. J. Ruben, *J. Magn. Reson.* **48**, 286 (1982).