

Current Calibration Status of the Suzaku XIS

Hideki Uchiyama,

M.Ozawa, M.Nobukawa, H.Matsumoto, T.G.Tsuru, K.Koyama
(Kyoto University),

H.Nakajima, M.Uchino, K.Hayashida, H.Tsunemi,
M.Nagai, K.Kimura, H.Uchida, N.Anabuki (Osaka University),

H.Mori, T.Dotani, A.Bamba, K.Matsuta, M.Ozaki, M.Tsujimoto
(ISAS/JAXA),

K.Ogawa, S.Kawai, K.Mori, T.Kato, Y.Kimura, S.Aoyama,
Y.Ikegami, Y.Ishisaki (University of Miyazaki),

S.Kitamoto, H.Murakami, D.Takei (Rikkyo University),

T.Kohmura (Kougakuin University),

Y.Ishisaki (Metropolitan University),

E.D.Miller, B.LaMarr, M.Bautz (MIT),

Suzaku XIS team

Index

1. XIS system
 2. Spaced-row Charge Injection
 3. Contamination
 4. Window mode calibration
 5. 2x2 data mode calibration
- Please refer Terada-san's presentation for timing calibration.
 - We are also studying
 - gain and quantum efficiency around Si-edge energy
 - gain and efficiency of atypical telemetry mode (2x2 edit mode)
 - regularly updating non-X-ray background

1. X-ray Imaging Spectrometer (XIS) = X-ray CCD

Picture of one CCD camera

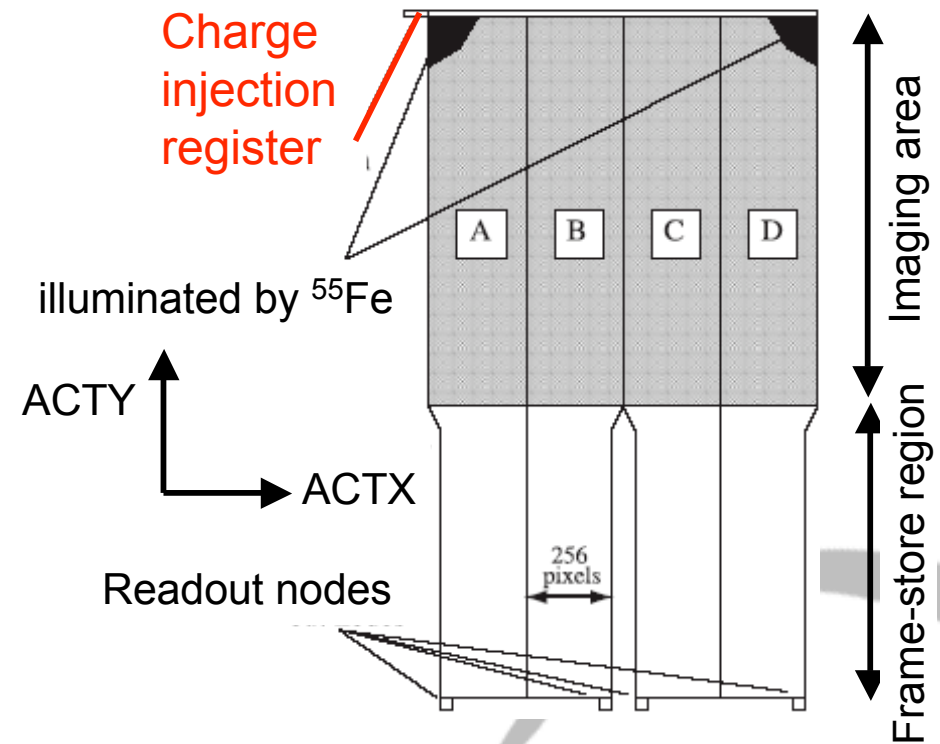
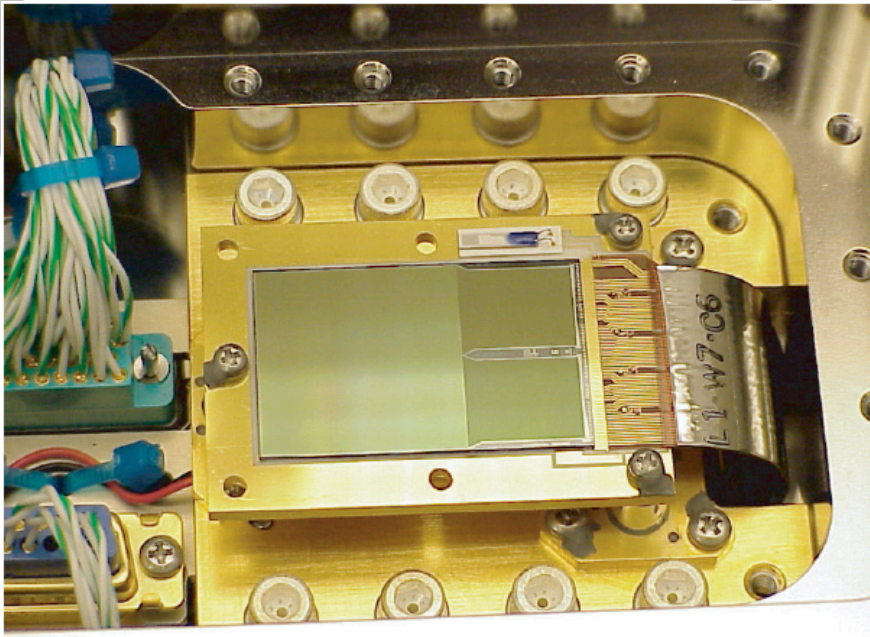

- 4 CCD cameras (XIS0, 1, 2, 3)
 - XIS0 & XIS3 ... Front-Illuminated CCD (FI)
 - XIS1 ... Back-illuminated CCD (BI)
 - XIS2 ... No operation (malfunction on Nov. 9, 2006)
- They have been operating since August 2005.

2. Spaced-row Charge Injection (SCI)

Charge injection method to improve charge transfer inefficiency (CTI).

Frame image of XIS

Charge injection

Charge moves down during readout.

Transfer direction

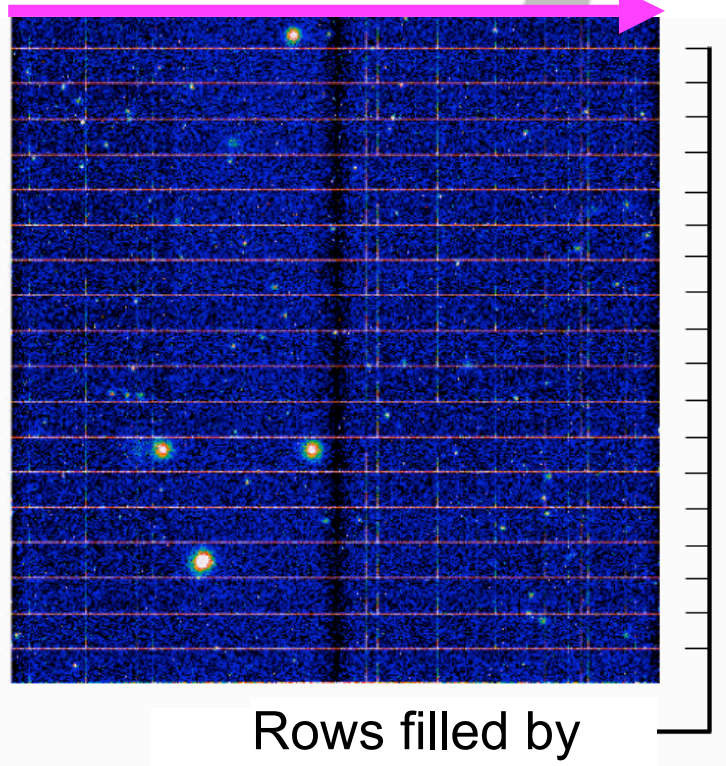

Rows filled by charge injection. (every 54 rows)

Trap causing CTI

Injected charge: sacrificial event

X-ray event

Time

Transfer direction

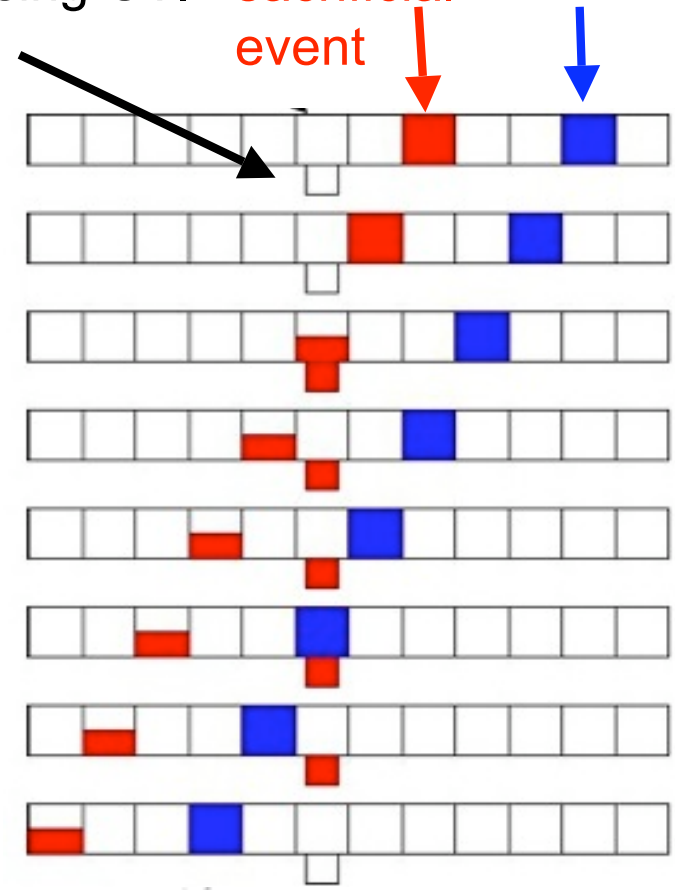

Spectra of onboard cal source ^{55}Fe
@ Sep. 2006(14 months after launch)

Spatial non-uniformity of pulse height
of Mn I $K\alpha$ line centroid

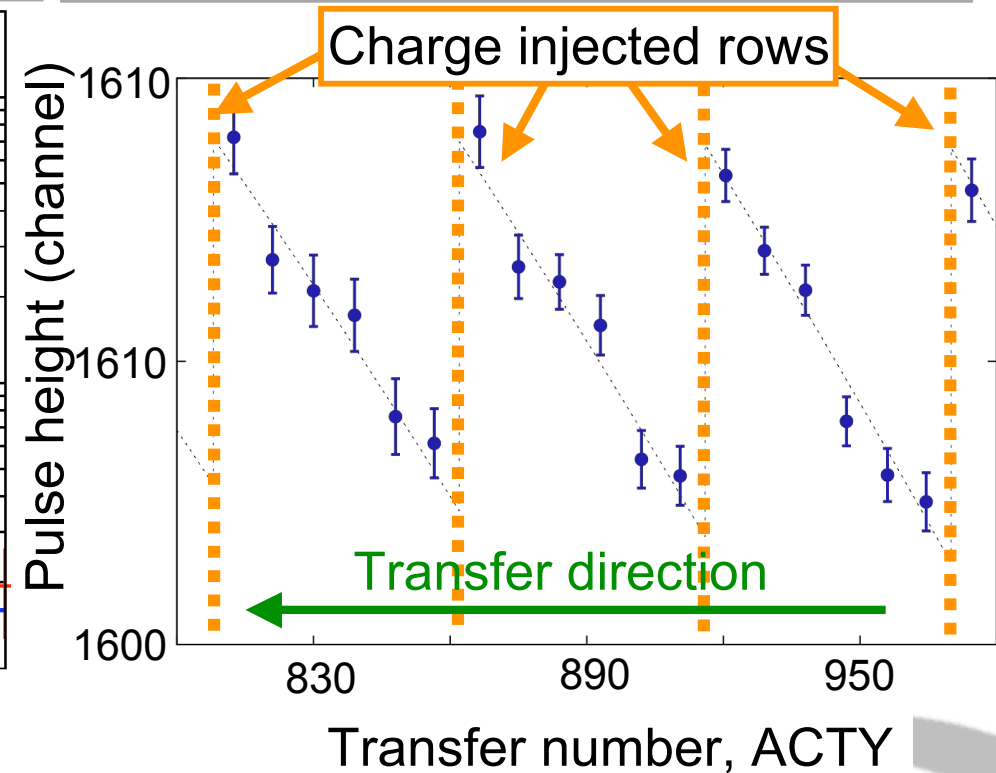
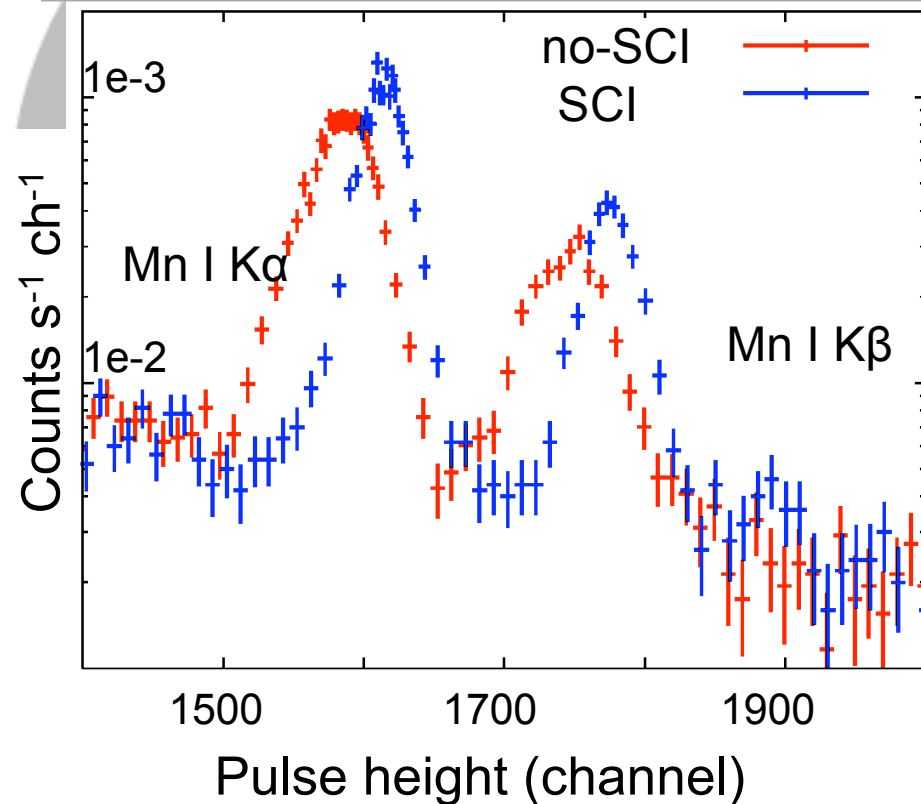

- We verified the recovery of the energy resolution from 210 eV to 150 eV (@5.9 keV,FWHM) at 14 month after launch.
- We found spatial non-uniformity of pulse height of Mn I $K\alpha$ line centroid.

Saw-tooth CTI correction method

- We modeled CTI as a “saw-tooth” function of ACTY. It reproduces observed non-uniformity of pulse height nicely.
- Now we decide C_t and C_b using data of cal source and Perseus Cluster.

If you want to know details, please read Uchiyama et al. 2009 PASJ 61 S9-S15.

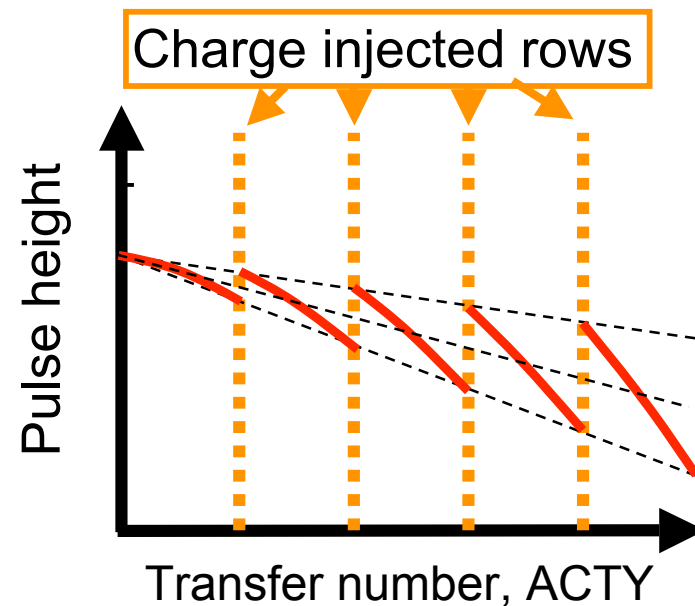
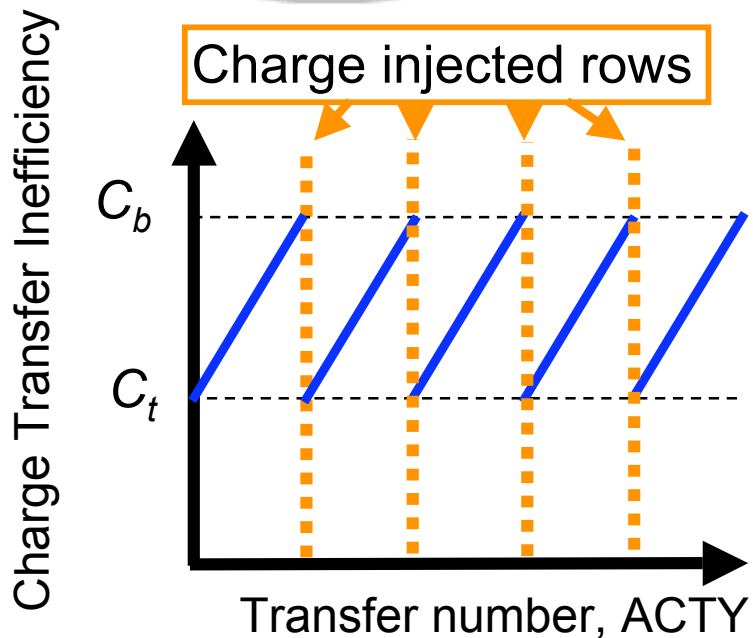
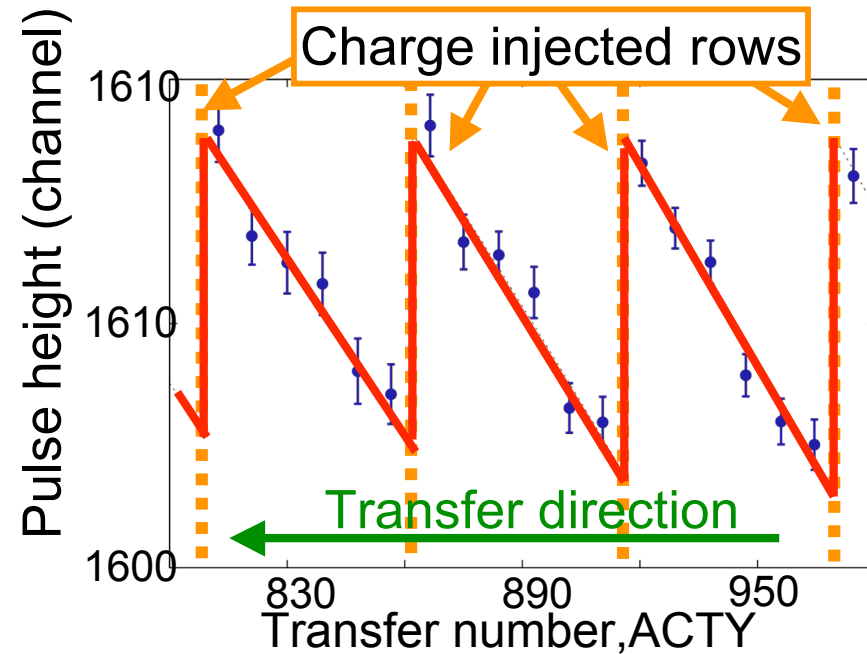

- SCI has been operated as normal observation mode since December 2006.
- No anomaly related to SCI has happened so far.
- All SCI data are corrected with the saw-tooth method.
- High energy resolution is maintained now thanks to SCI.

SCI is working well without big problems !

Time history of line centroid of cal source (Mn I $K\alpha$: 5.895 eV)

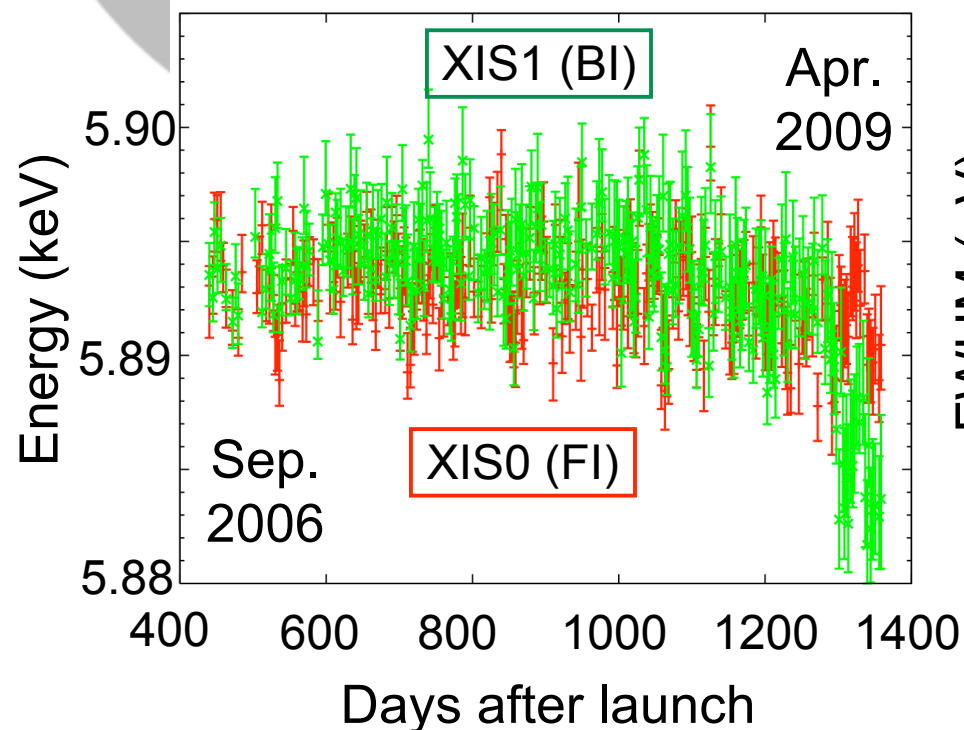

Time history of energy resolution (@5.9 keV, FWHM)

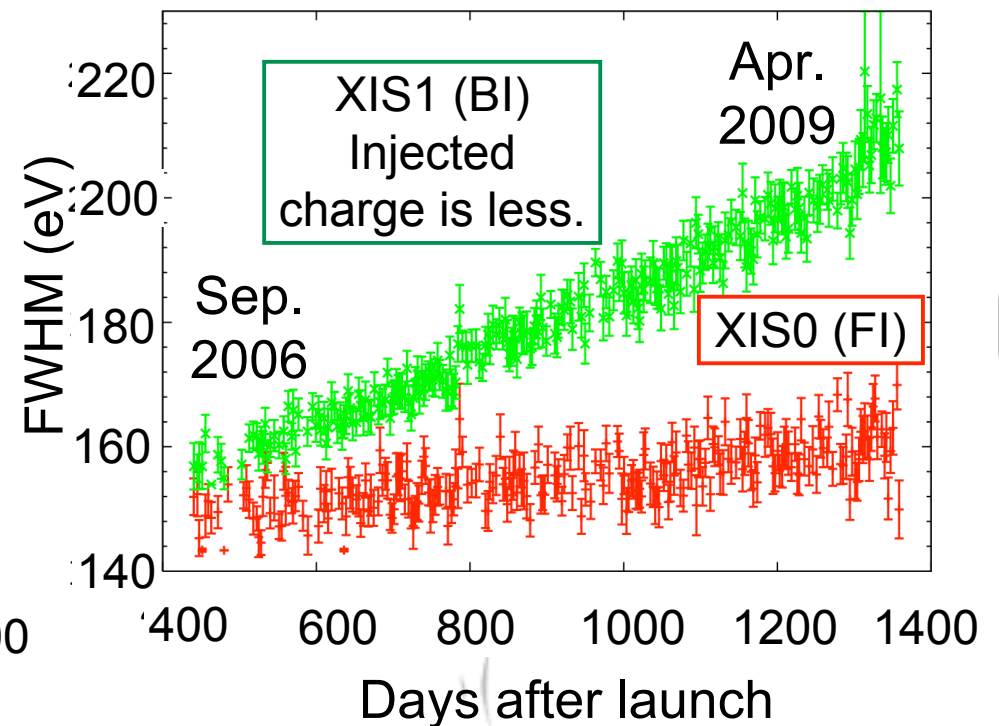

3. Contamination on the XIS

- soft response (< 1 keV) degraded after launch
- varies with time, position on detector → **detector**
- molecular contaminant on OBFs
- composition uncertain
 - assume DEHP (plasticizer) from IRU; $C_{24}H_{38}O_4$
 - Now we assume C:O = 6:1
- monitoring
 - on-axis: **E0102** (monthly), RXJ1856, PKS2155
 - full-field: **bright Earth** (monthly), Cygnus Loop, clusters

On-axis Contamination

- Measured with the data of E0102.

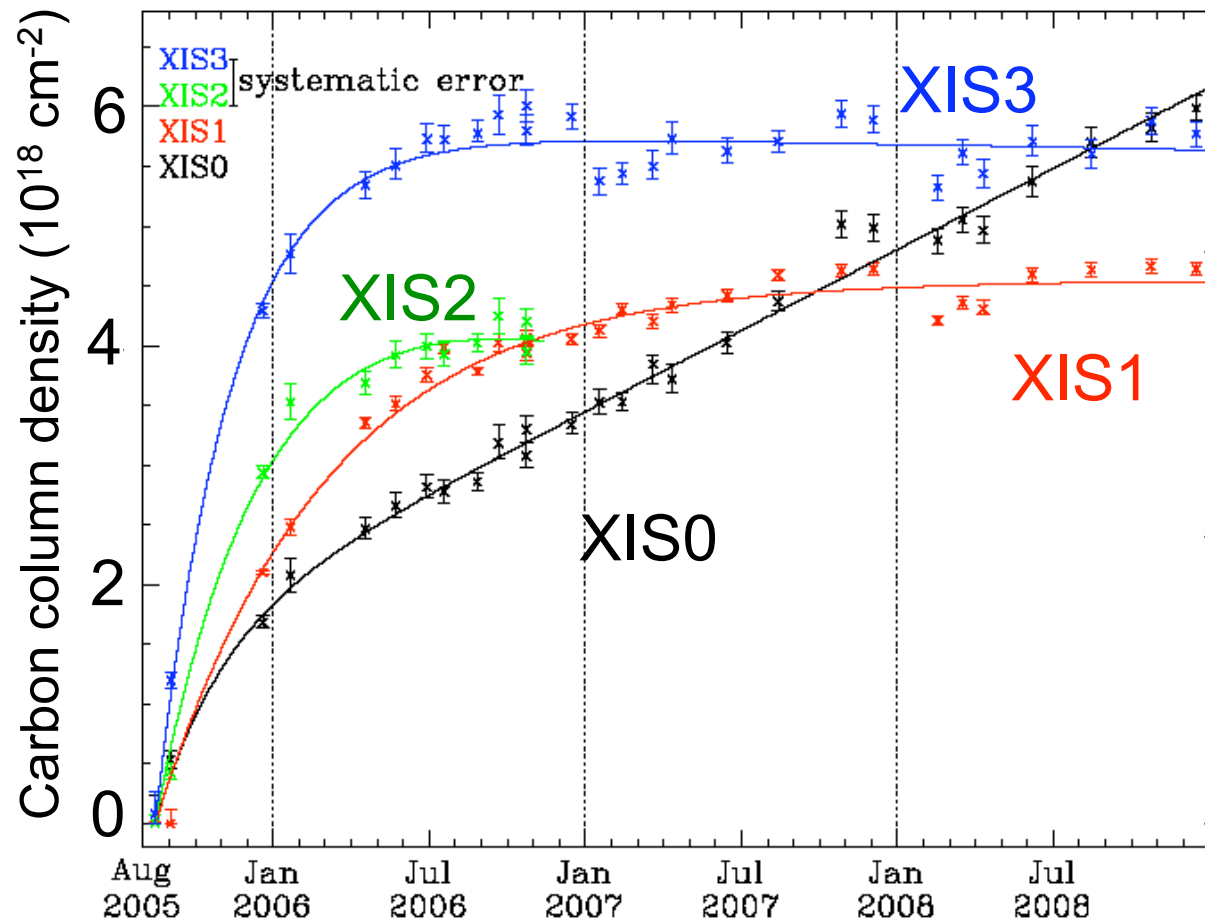

- Contaminations of the XIS1,3 seem saturated.
- Contamination of the XIS 0 is increasing

Full Field Contamination

- Measured with bright earth data
- Especially using fluoresce neutral N-K α and O-K α lines
- Regularly updating model parameters

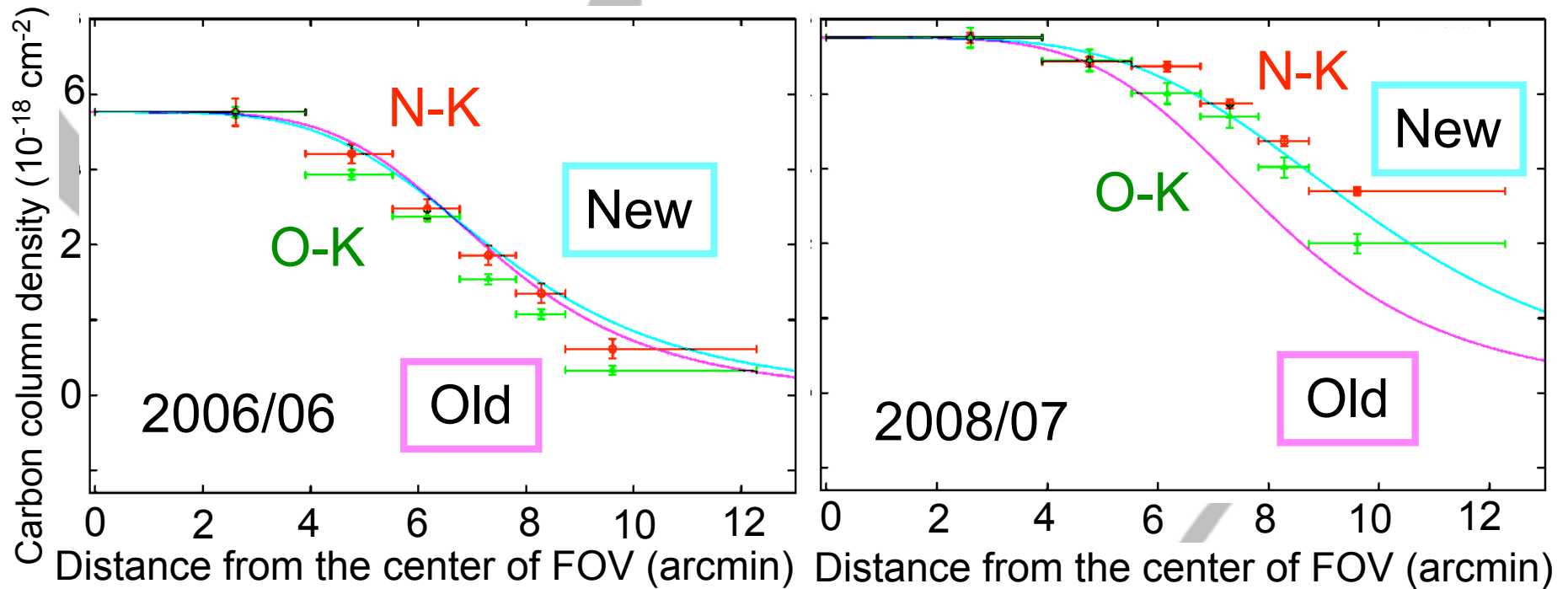

Contamination around the outer corner

- The results based on N-K and O-K lines are different.
- Now we assumed contamination consists of only carbon and oxygen. C:O=6:1.
- If contamination includes nitrogen, this difference can be explained.
- The results of the center do not require nitrogen absorption.

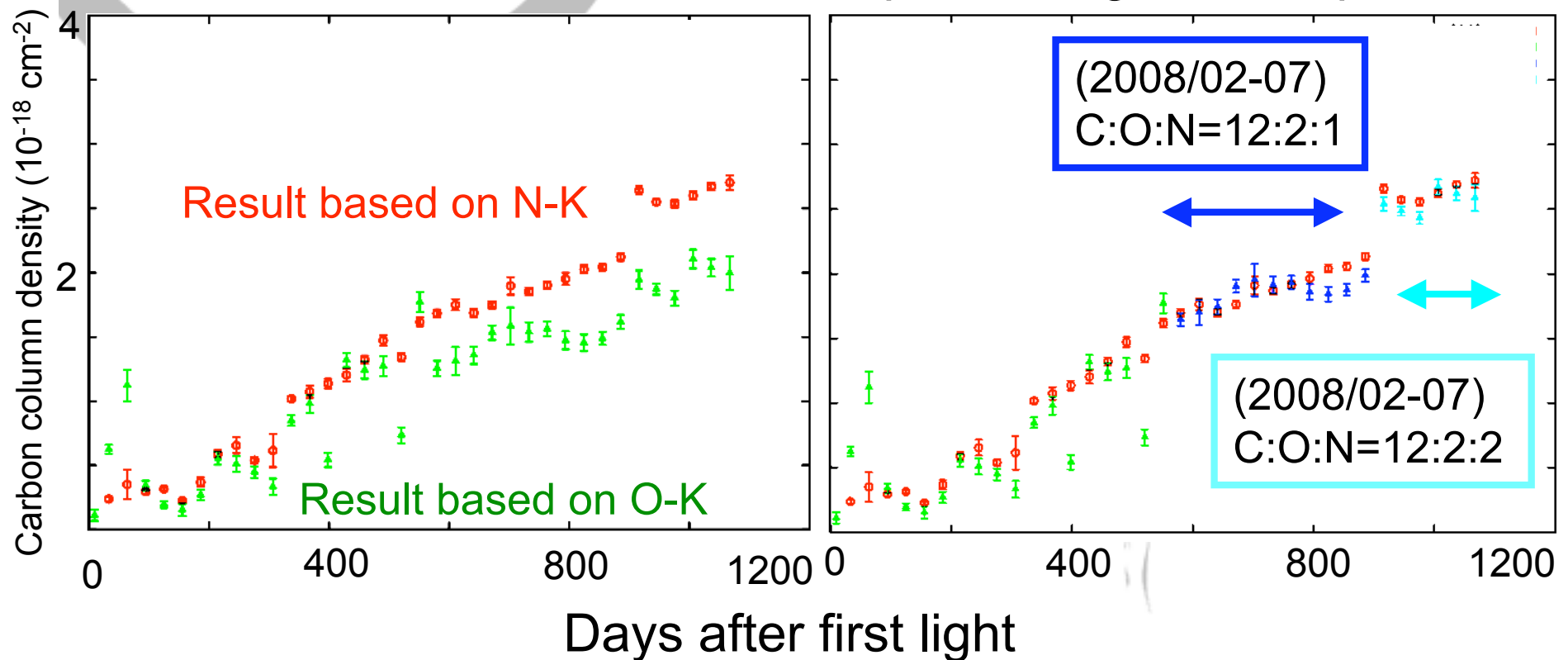

4. Window mode calibration

- Window mode option
 - readout only partial region of imaging area.
 - avoid pile-up and make time resolution high.
(ex. exposure time per 1 frame
full window: 8 sec \rightarrow 1/4 window: 2 sec)

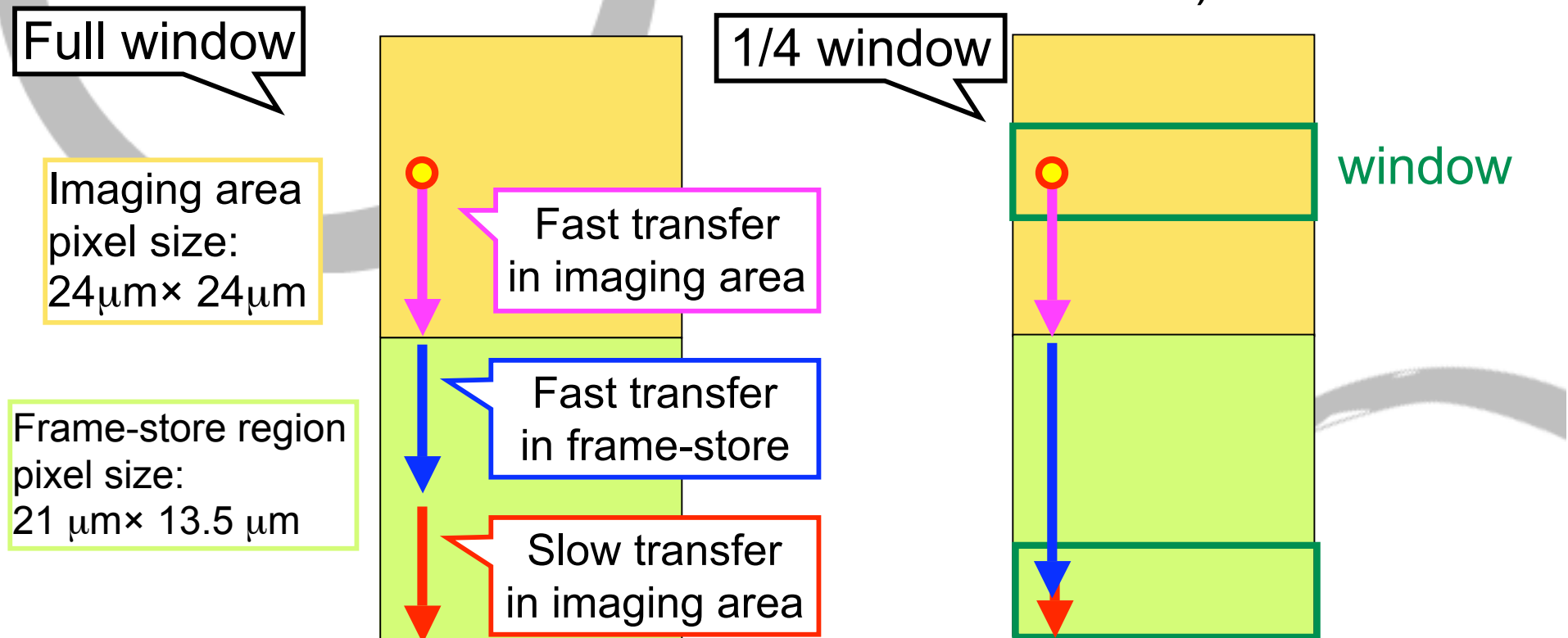

The numbers of slow and fast transfers are different between full and partial window modes.

Pulse heights of cal source with full and 1/4 window mode

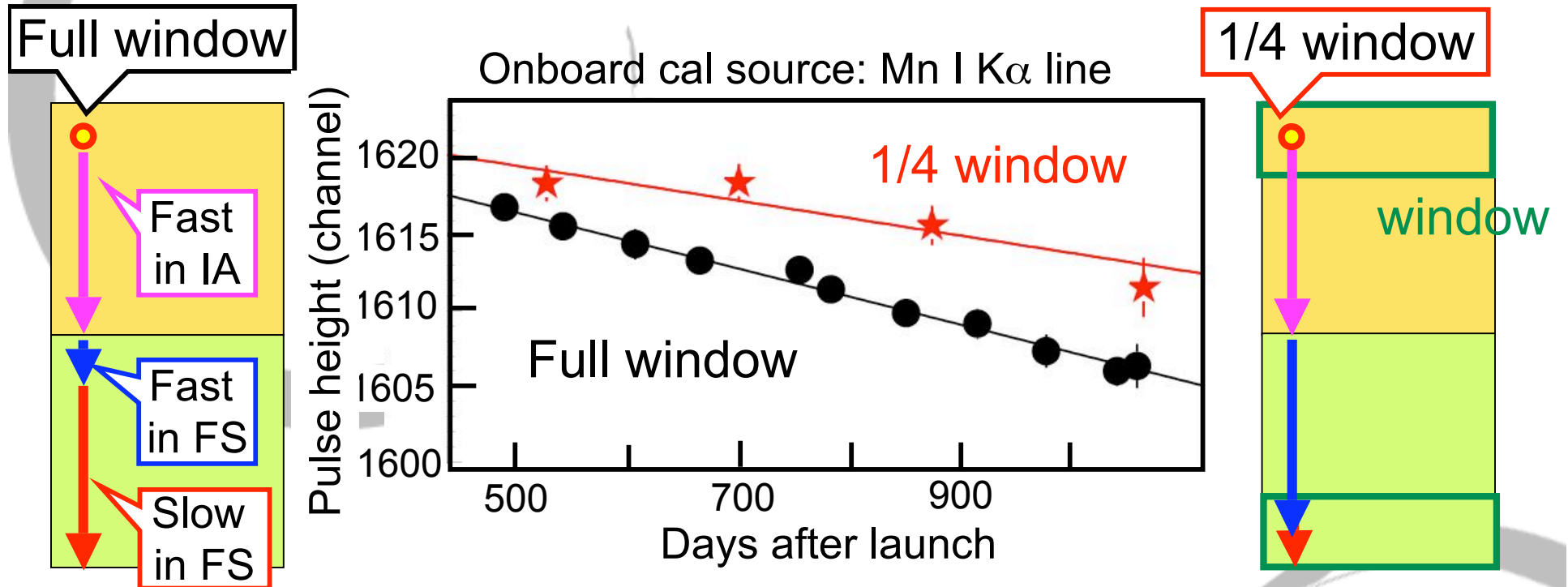

- It shows CTI of fast transfer is smaller than that of slow transfer.
- Now we corrected CTI of partial window mode considering its dependence on transfer speed.

Summary

- Spaced-row Charge Injection (SCI)
 - SCI has been operated as Suzaku XIS normal observation mode since December 2006.
 - SCI data are corrected with the “saw-tooth” CTI correction method.
 - SCI is working well with no problem. Energy resolution is maintained high.
- Contamination
 - On-axis: Contaminations of XIS 1, 3 seem saturated. XIS 1 keep increasing.
 - Full field: 2-dimensional model updating constantly
 - Outer corner : including nitrogen?
- Window mode
 - we corrected CTI of partial window mode considering its dependence on transfer speed.

Please tell me if you need saw-tooth
CTI correction paper(s).

Appendix. 2x2 edit mode calibration

- 2x2 edit mode to avoid telemetry saturation for bright sources.
 - Normally we use 3x3 or 5x5 edit mode.
 - In the case of 2x2 edit mode,
 - it is difficult to judge X-ray grade properly.
 - we cannot correct charge-trail effect.
- Detection efficiency and gain can be changed.

5x5 edit mode

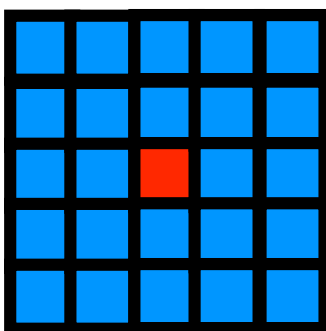

3x3 edit mode

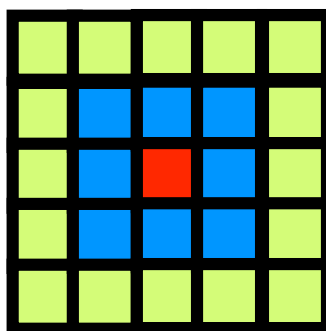

2x2 edit mode

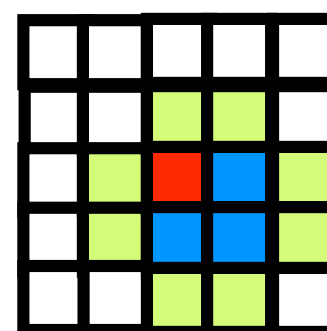

Event center (Pulse height is output.)

Pulse height is output.

Whether or not its pulse height exceeds the threshold is output .

- We made “pseudo” 2x2 data from 5x5 data and compare analysis results of the pseudo 2x2 data and original 5x5 data.
- Compared with X-ray grade events of the original 5x5 data, those of the pseudo 2x2 data increases by $\sim 0.2\%$.
 - Some non-X-ray events are judged as X-ray but ignorable.
- Summed pulse heights of 2x2 data is smaller than that of 5x5 edit mode by ~ 10 eV systematically.
 - We adjusted gain for 2x2 edit mode.

