

# Glove Mouse

Tony Kim

Nevada Sanchez

# Project Goals

- Implement LED glove mouse.
  - Interface with NTSC camera.
  - Track two distinct objects with video input.
  - Control multiple cursors in an application.
  - Install multiple buttons to allow robust gesturing input scheme.



# Motivations

- Map viewer.
- Virtual object manipulation.
- Mechanical device control.

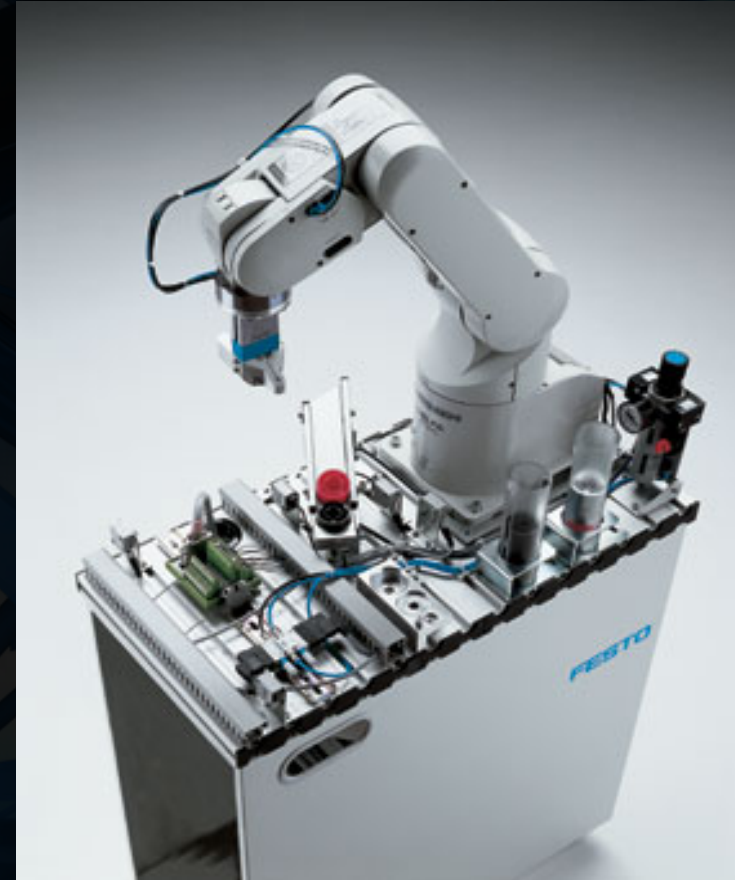

# Overall Design

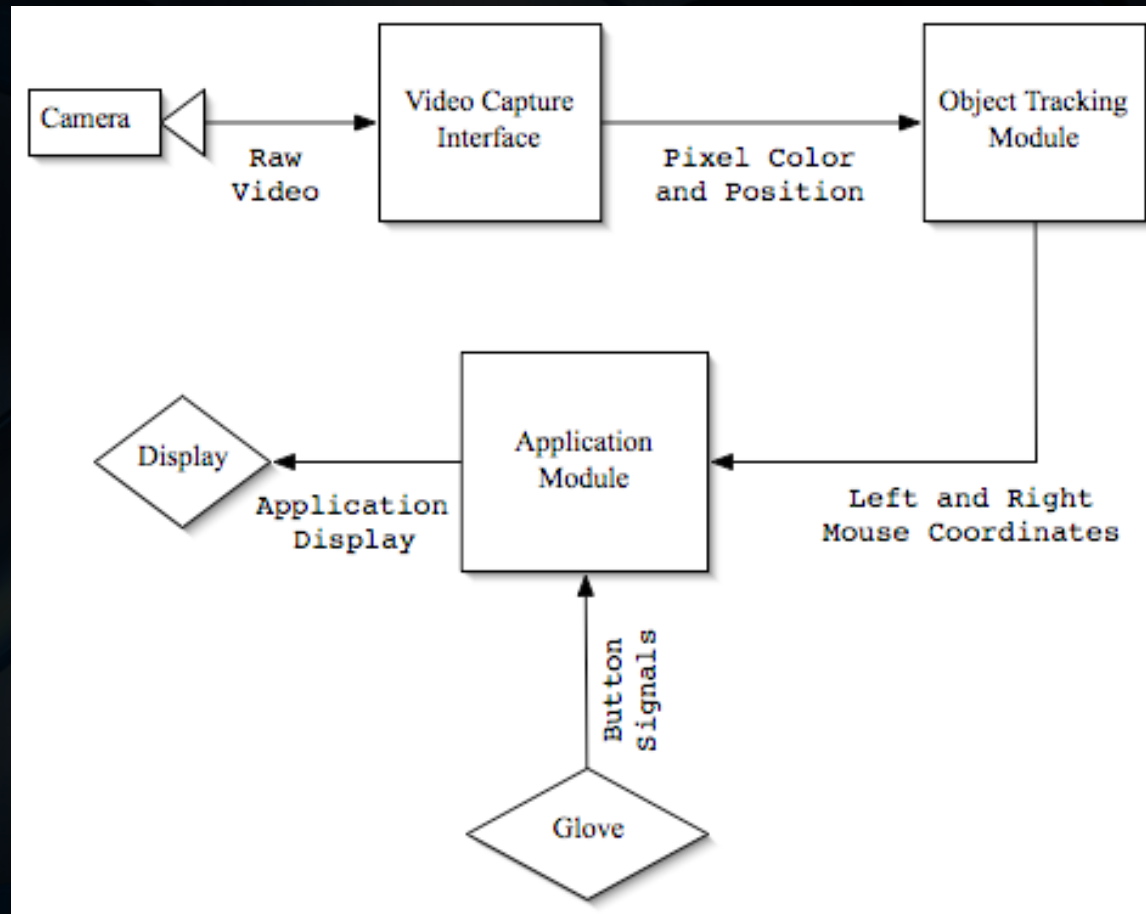

# Map Application

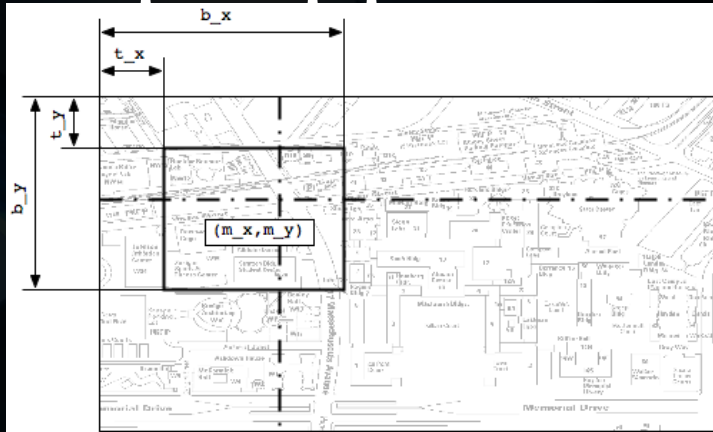

Map

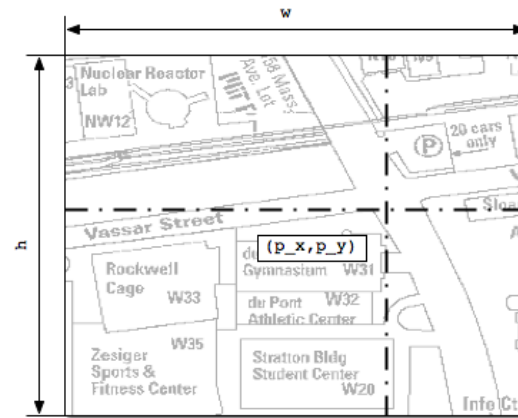

Display

# Weighted Avg. Video Tracker

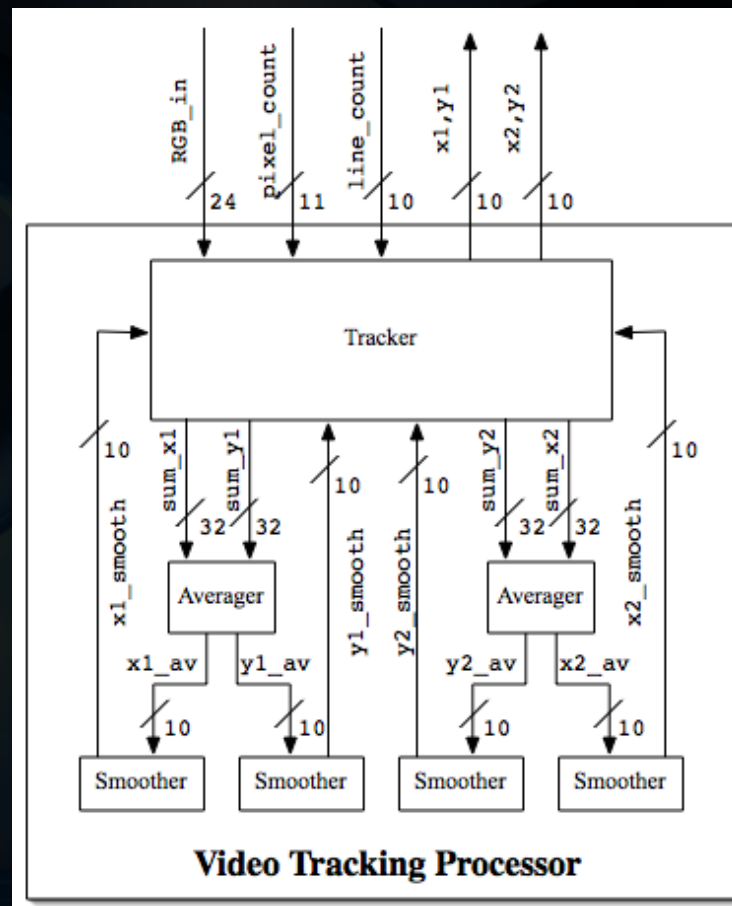

# Video Capture - Block Diagram

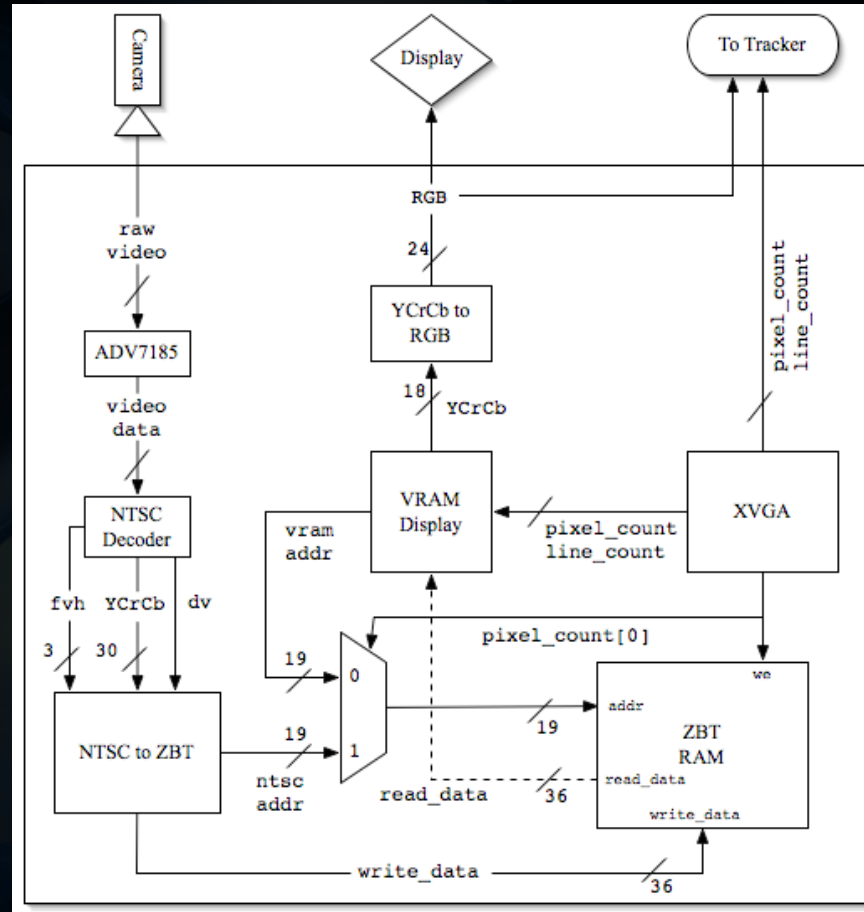

# Tracking Objects

- Left and Right distinguished by color.
- Filter video to single out each LED.
- Use 'running average' scheme to find mouse coordinates.
- Transform coordinates based on view layout specifications.



# Map Application Diagram

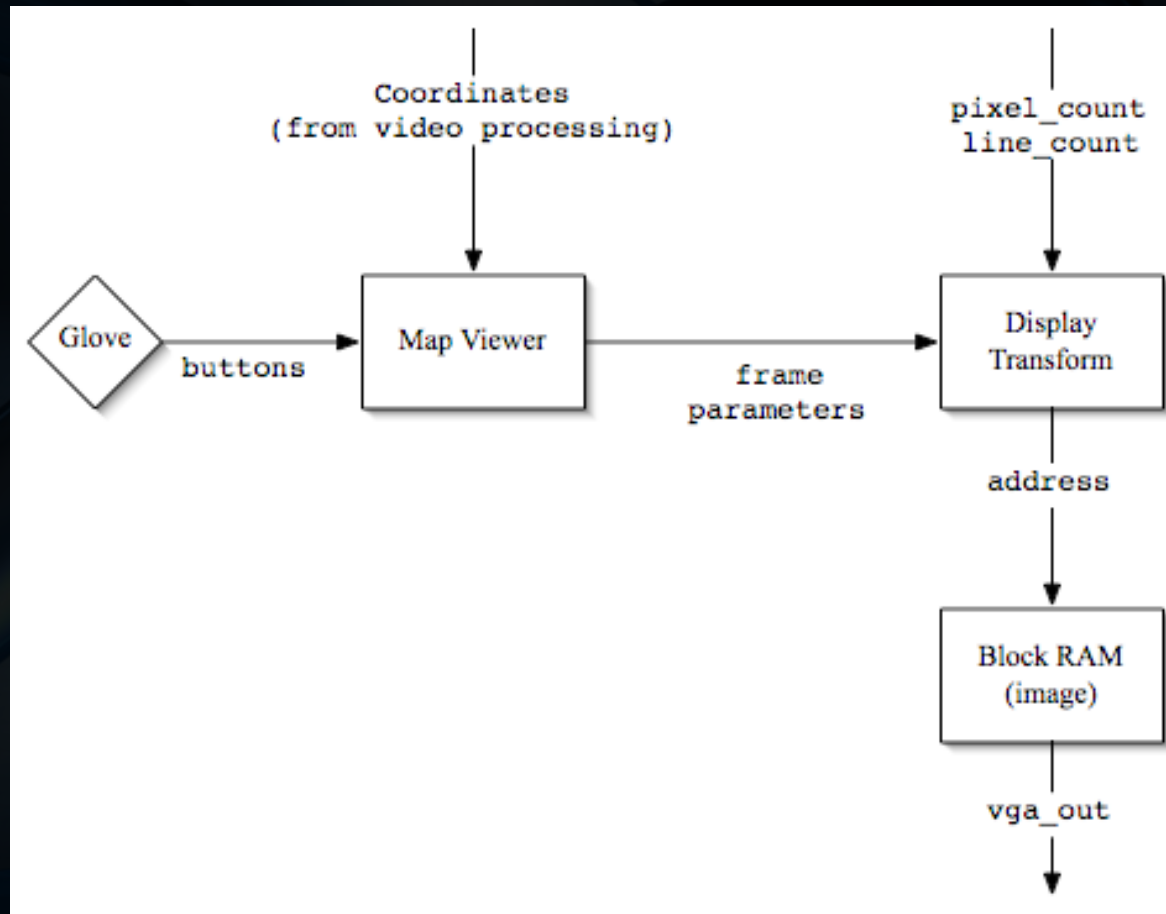

# Conclusion

- Current Progress
  - Video capture nearing completion.
  - Rudimentary filtering (for tracking).
- Possible Extensions
  - More applications.
  - Wireless glove.
  - PS/2 mouse input for tracking.

# Questions?

