

AOSN-II in Monterey Bay and the California Current System: Modeling and Predicting Multiple Scales and Processes

Allan R. Robinson and Pierre F.J. Lermusiaux

Division of Engineering and
Applied Sciences

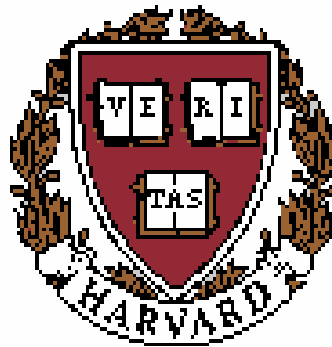

Department of Earth and
Planetary Sciences

<http://www.deas.harvard.edu/~robinson>

Table of Contents

1. AOSN-II Real-time forecasting (HOPS)
2. Multi-Model Forecasting
3. Multi-Scale Energy and Vorticity Analysis
4. Tides and Coupled Biology
5. Real-time Error Subspace Statistical Estimation (ESSE)
6. Quantitative Autonomous Adaptive Sampling

Day N

Day N+1

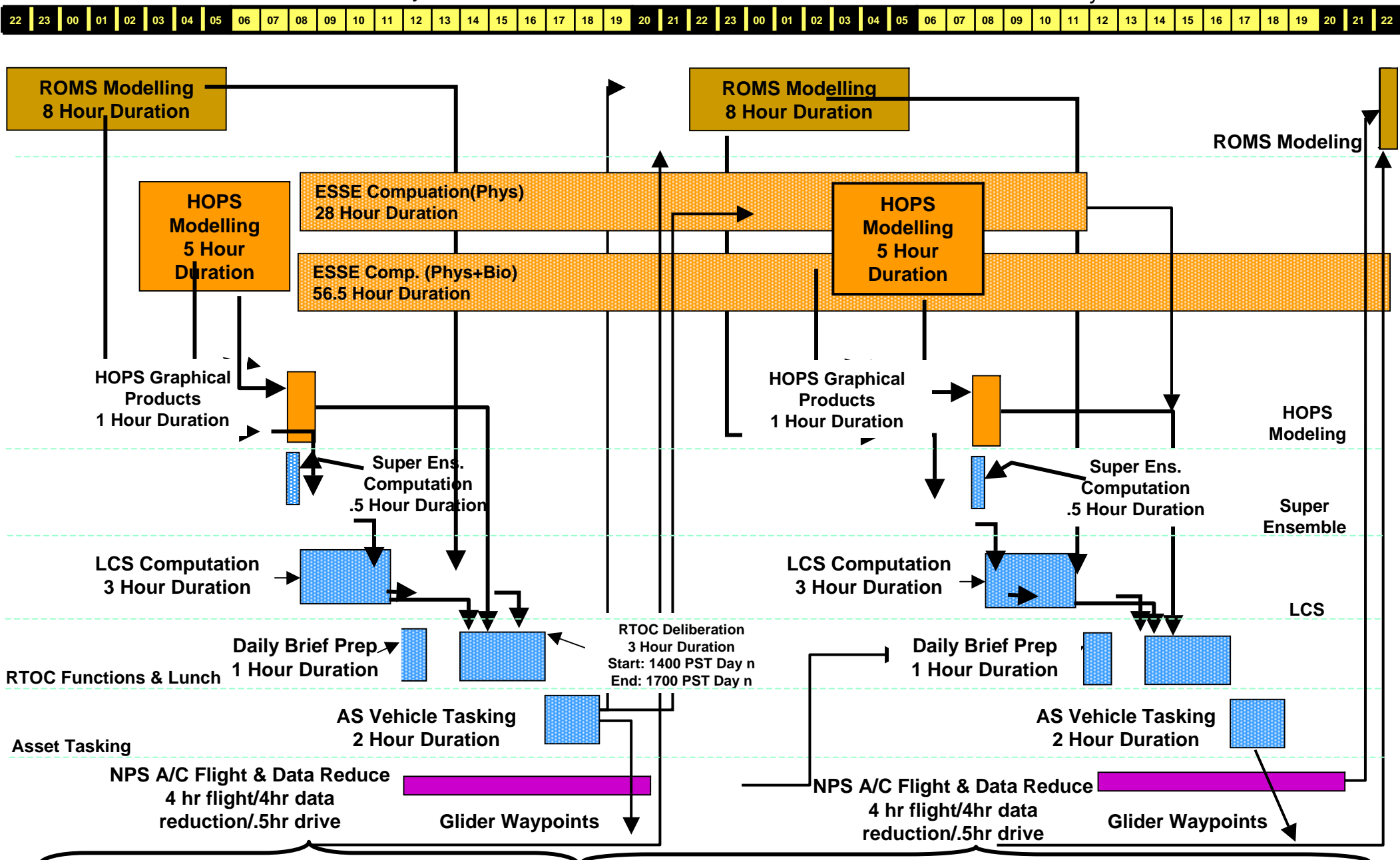

Two-scale Adaptive Sampling:

- Daily identification of features and errors from model forecasts
- Two-hourly data feedback for glider coordination

10m Temperature from Re-Analysis Model Output

*Note: models
assimilate
different data*

7 August 2003

3 GTM, 8/7/2003

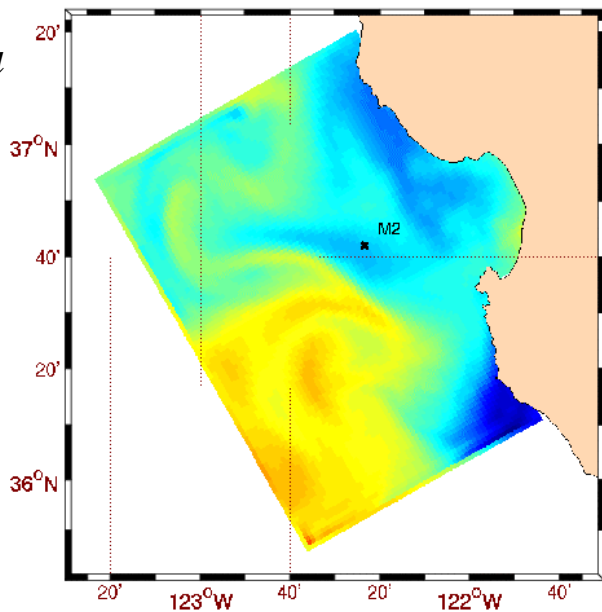

HOPS

21 August 2003

21 GTM, 8/21/2003

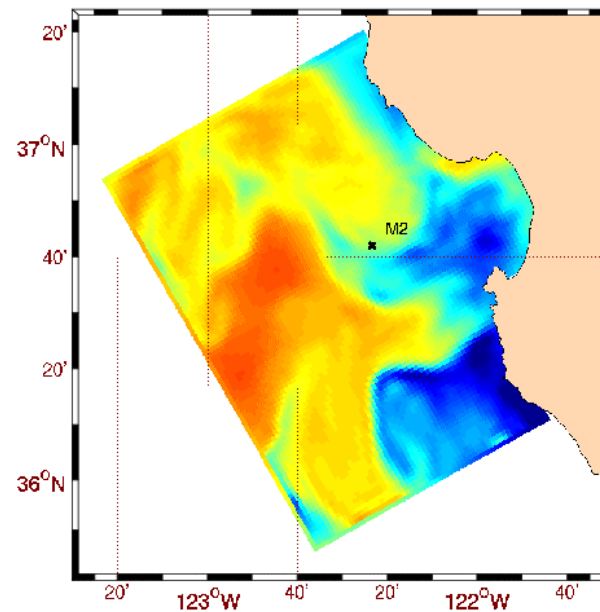

Beginning of Experiment

Relaxation

3 GTM, 8/7/2003

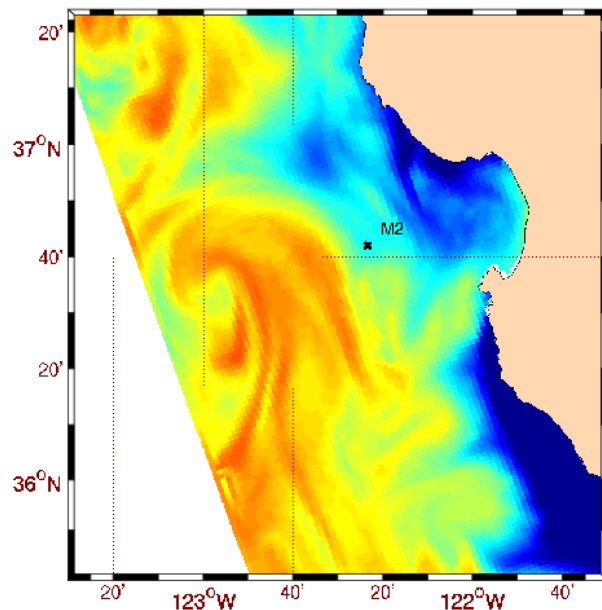

ROMS

21 GTM, 8/21/2003

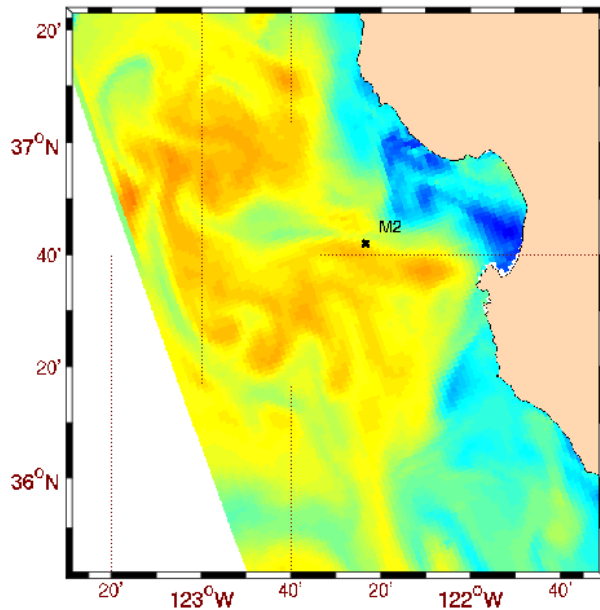

HOPS - AOSN-II Real-Time Forecasting

- 23 sets of real-time nowcasts and forecasts of temperature, salinity and velocity released from 4 August to 3 September
- Forcing: 3km COAMPS, Calif. Current System flow-through, Internal dyn.
- Data from glider fleets, aircraft, ships, etc. archived in real-time at MBARI. Daily ftp to Harvard for quality control, analysis and processing.
- Real-time daily operational five day runs with OI (two assimilation days, nowcast, two forecast days) were available for post-processing at 4PM EDT
- Forecast features analyzed and described daily formed the basis for adaptive sampling recommendations for the 2PM (PDT) Real-Time Operational Committee (RTOC) meetings at MBARI
- Web: <http://www.deas.harvard.edu/~leslie/AOSNII/index.html> for real-time: field and error forecasts, scientific analyses, data analyses, special products, adaptive sampling recommendations and control-room presentations
- 10 sets of real-time ESSE forecasts for 4 Aug. to 3 Sep.:
270 – 500 ensemble members per day (stochastic model, BCs and forcings)

REGIONAL FEATURES of Monterey Bay and California Current System and Real-time Modeling Domains (4 Aug. – 3 Sep., 2003)

SST on August 11, 2003

Experimental AVHRR HRPT SST August 11, 2003 1850 h UTC

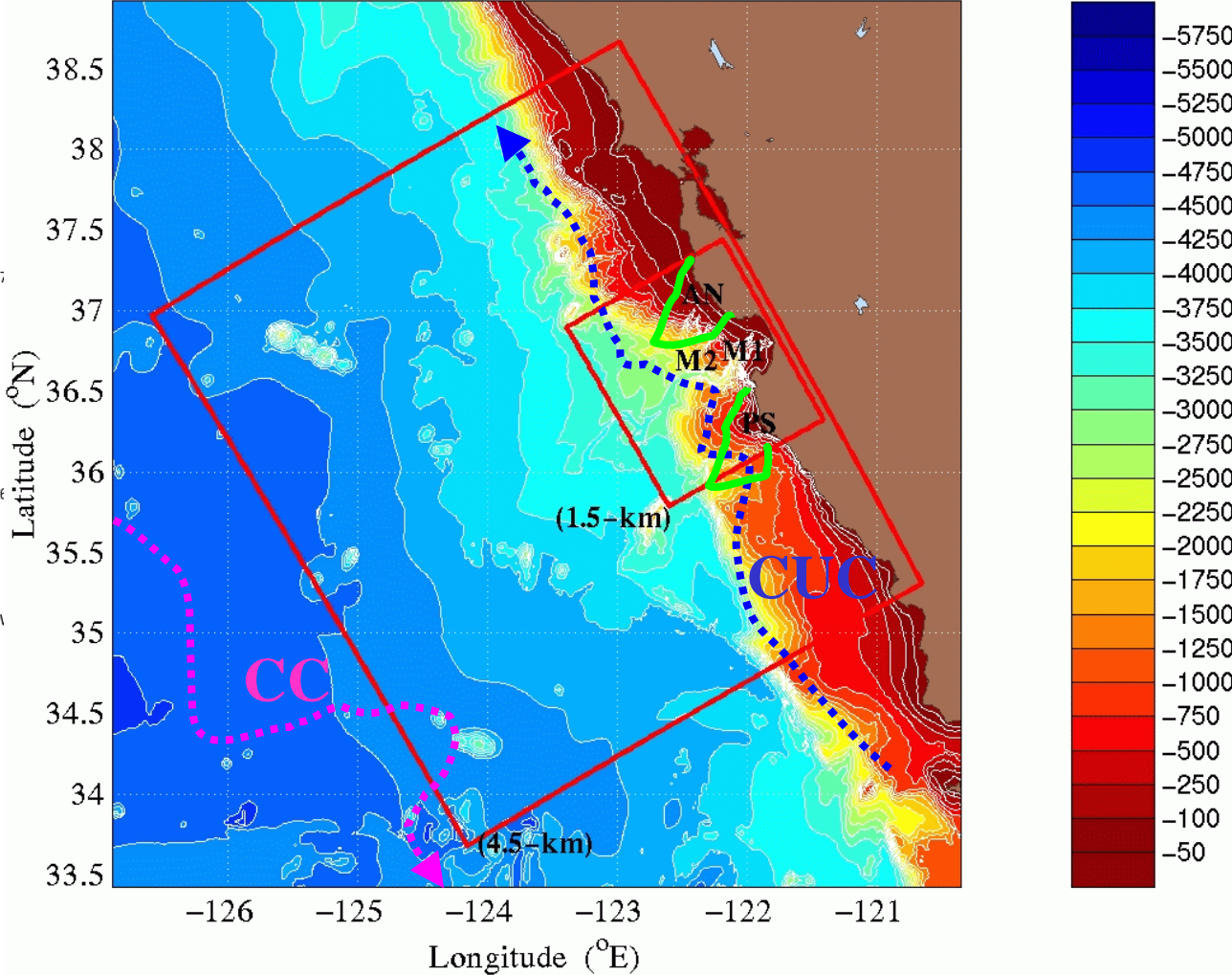
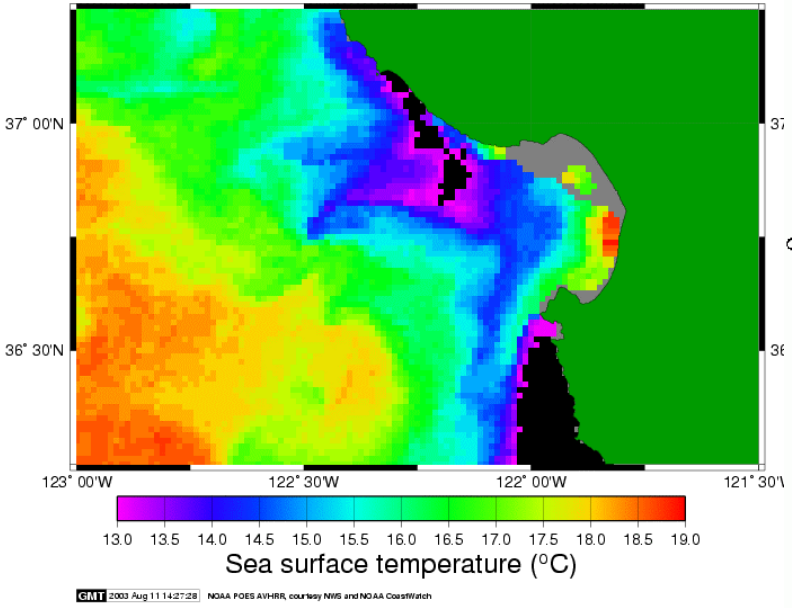

REGIONAL FEATURES

- **Upwelling centers at Pt AN/ Pt Sur:**.....Upwelled water advected equatorward and seaward
- **Coastal eddies, jets, squirts, filaments, etc. :**.....High submesoscale and mesoscale variability in the CTZ
- **California Undercurrent (CUC):**.....Poleward flow/jet, 10-100km offshore, 50-300m depth
- **California Current (CC):**.....Broad southward flow, 100-1350km offshore, 0-500m depth

Max Winds: 28.3 knots
on 11 August

Wind Vectors at Buoy M1 29 July – 7 September 2003

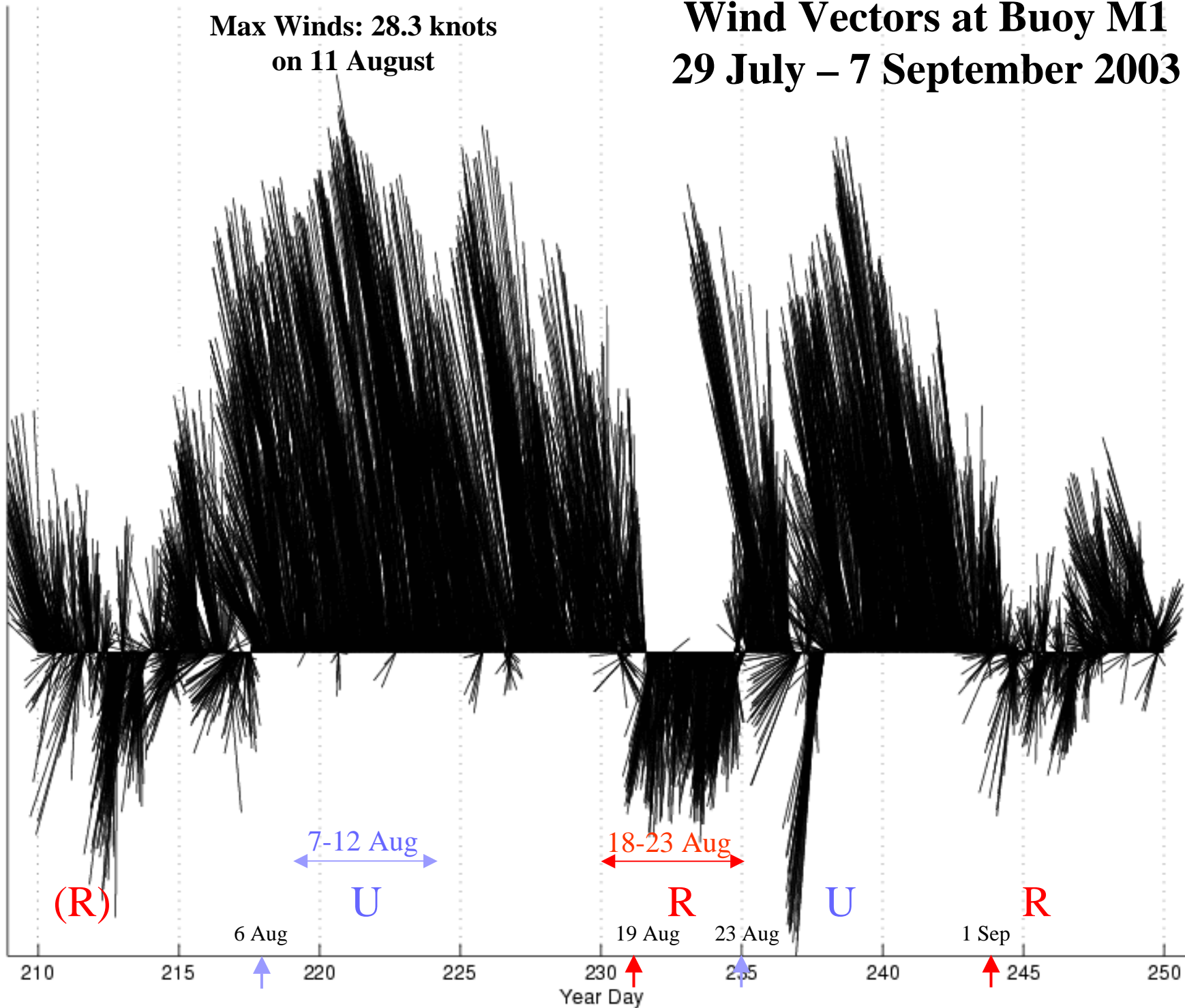

7-12 August – Onset and Sustained Upwelling Conditions

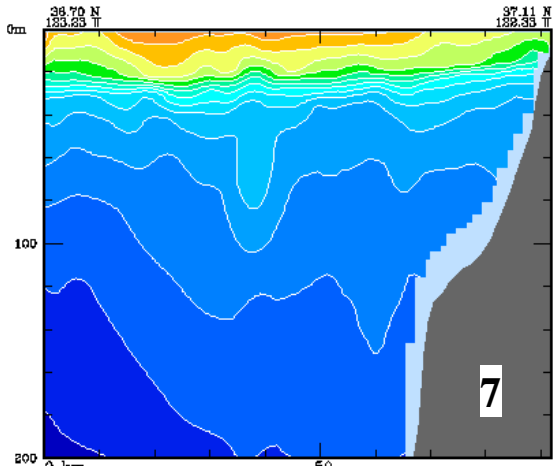

1.00 Day Forecast : 7 Aug 2003

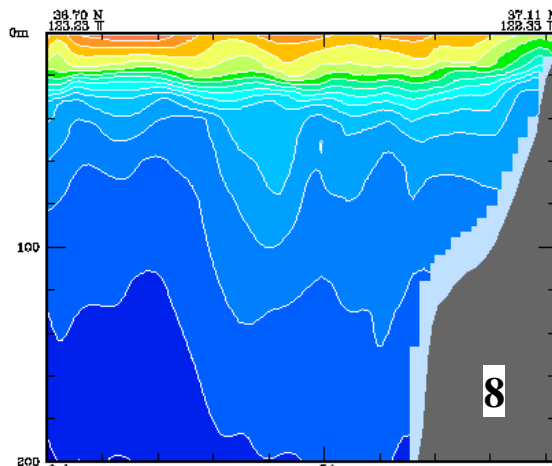

2.00 Day Forecast : 8 Aug 2003

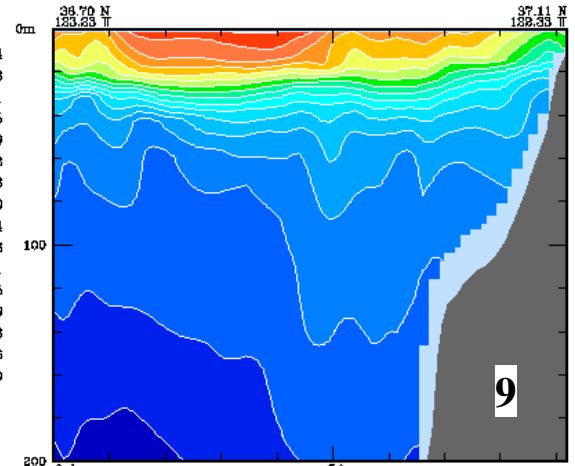

3.00 Day Forecast : 9 Aug 2003

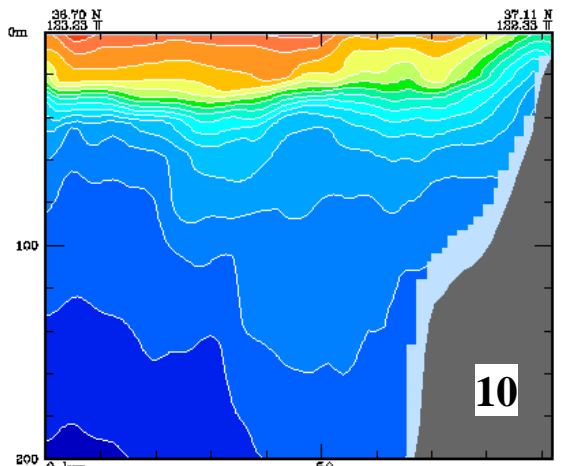

4.00 Day Forecast : 10 Aug 2003

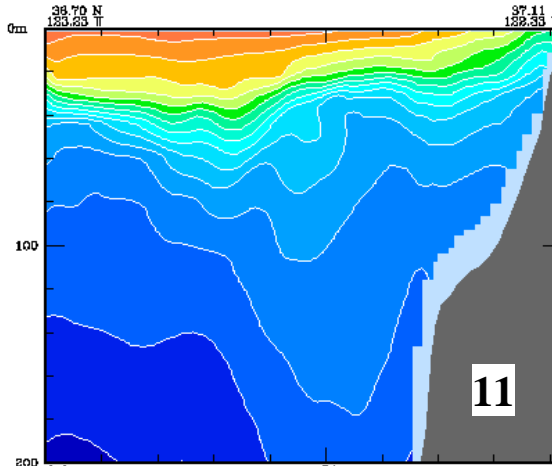

5.00 Day Forecast : 11 Aug 2003

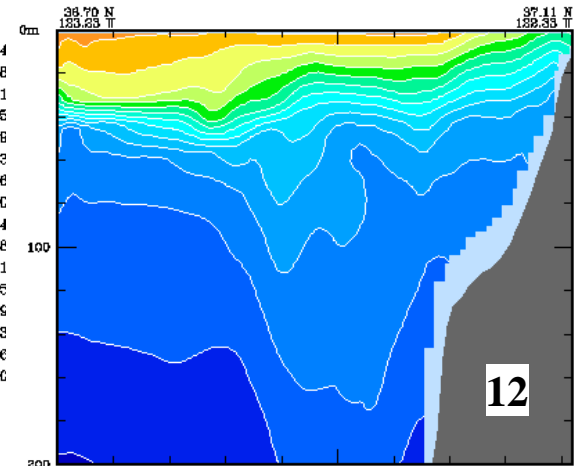

6.00 Day Forecast : 12 Aug 2003

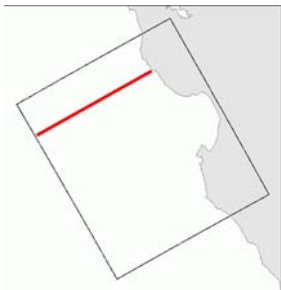

7-12 August – Onset and Sustained Upwelling Conditions

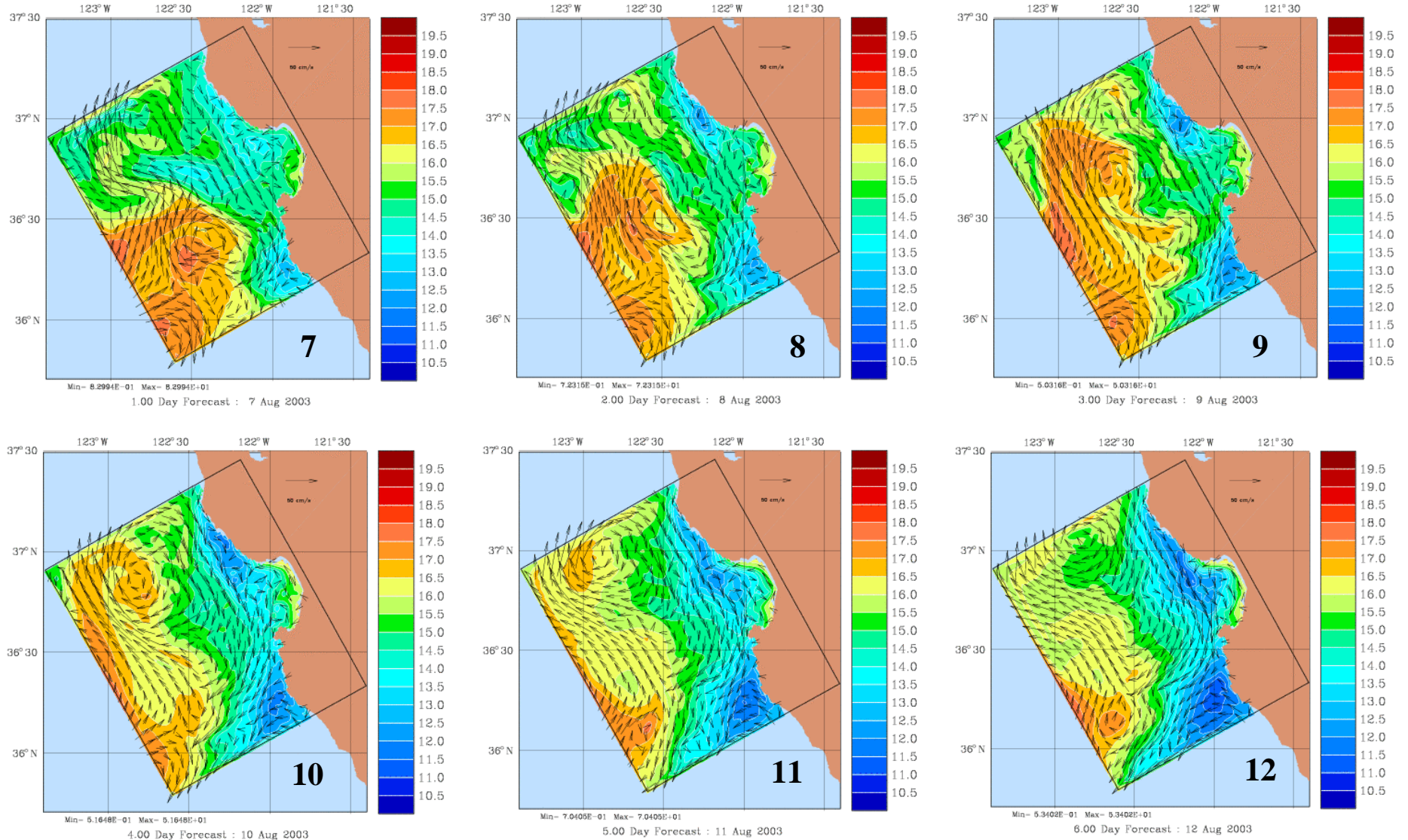

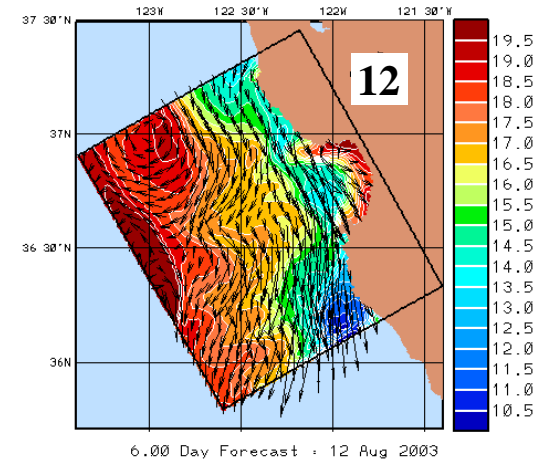
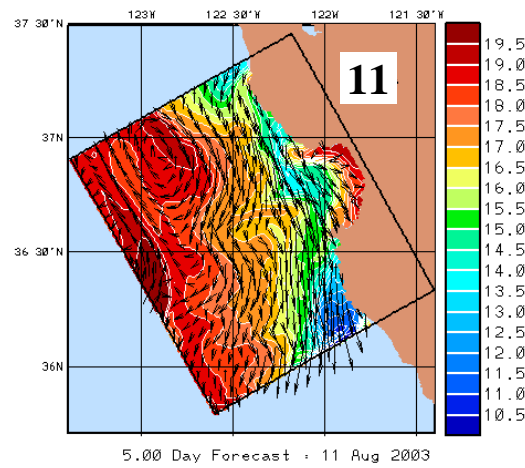
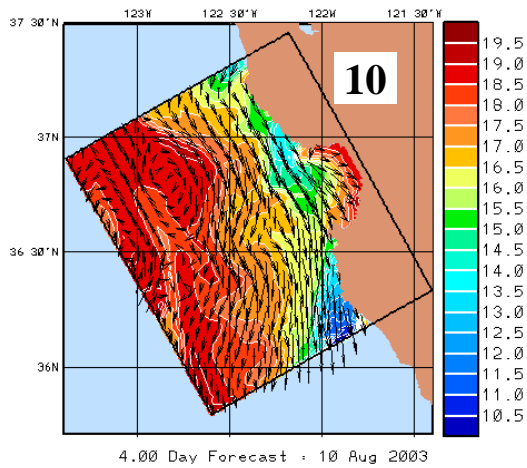

Sustained upwelling: comparison of real-time forecasts (top) with AVHRR SST (right) and re-analysis fields (bottom). Re-analysis fields and model output are available at: <http://www.deas.harvard.edu/~leslie/AOSNII/index.html>

Experimental AVHRR HRPT SST August 12, 2003 1827 h UTC

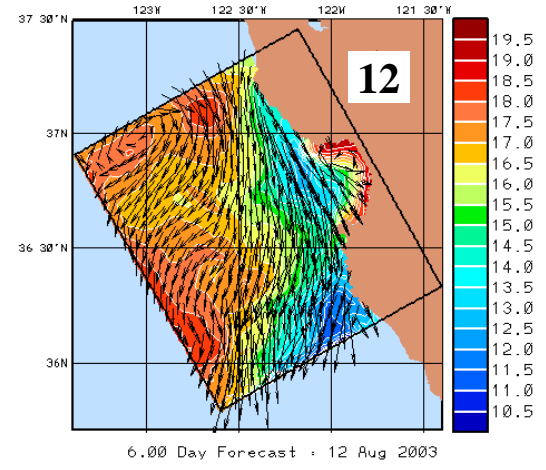
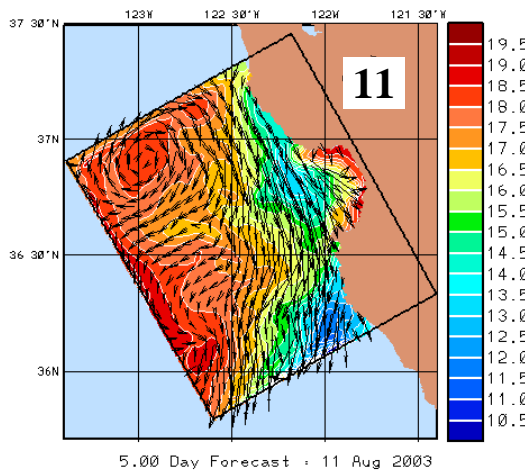
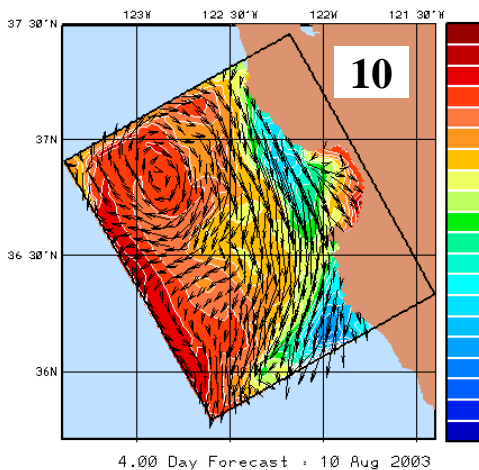
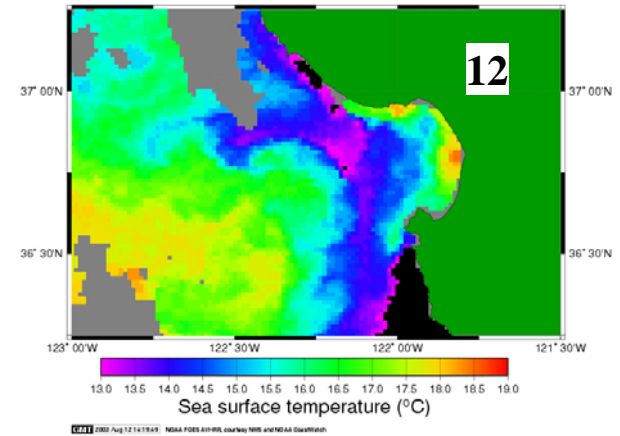

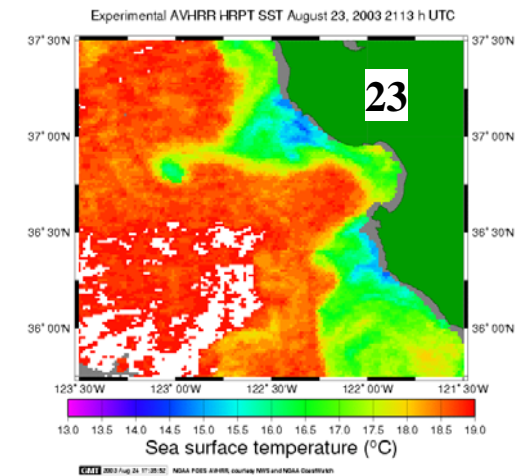
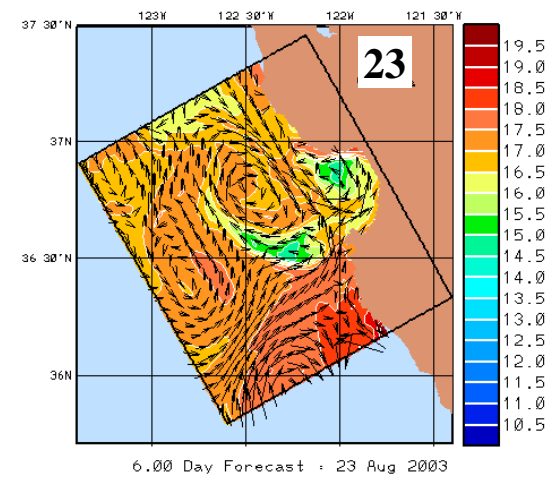
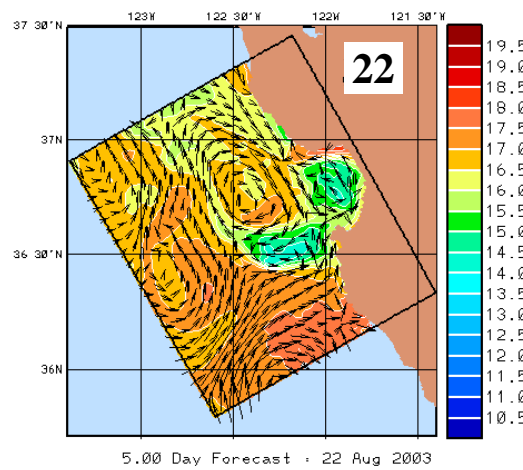
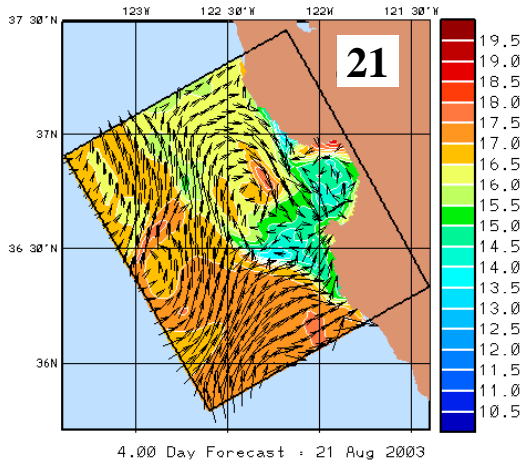

Relaxation: comparison of real-time forecasts (top) with AVHRR SST (right) and re-analysis fields (bottom)

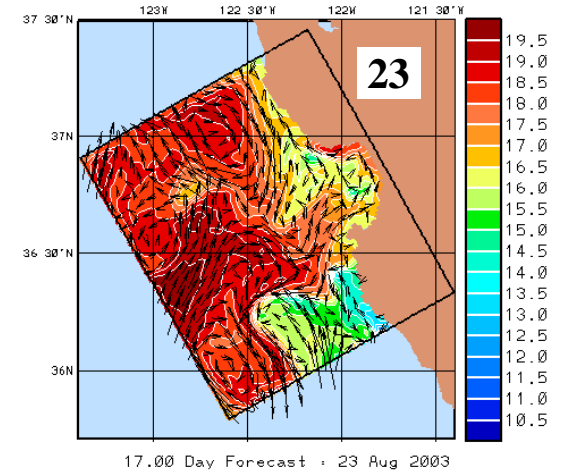
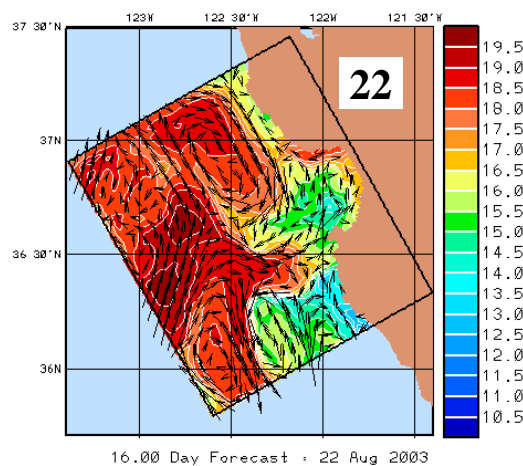
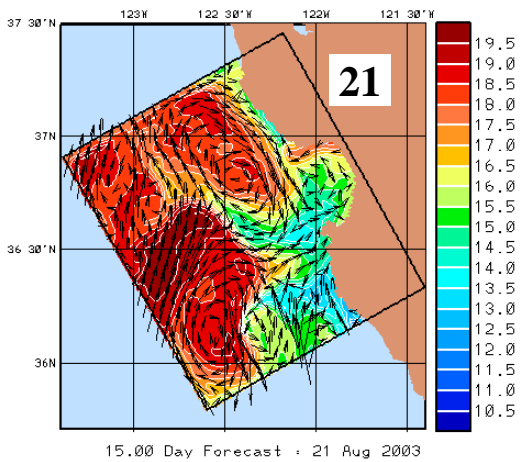

Forecast RMS Error Estimate– Temperature (left), Salinity (right)

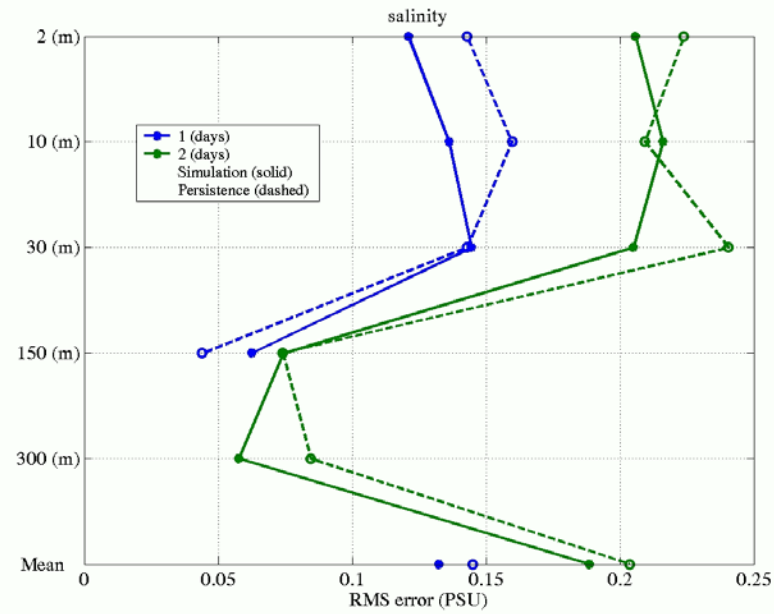
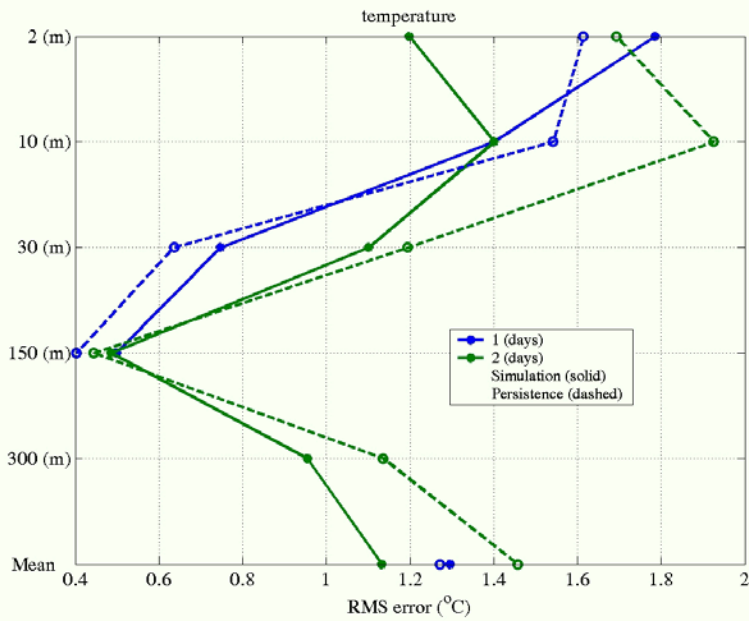

Blue – 12 Aug
Green – 13 Aug

Solid – Forecast
Dash – Persistence

T Difference (at 2m) for 13 August

Persistence – Data

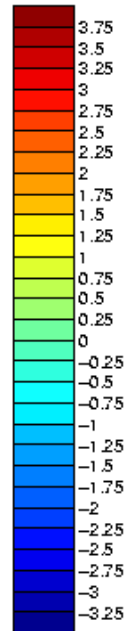
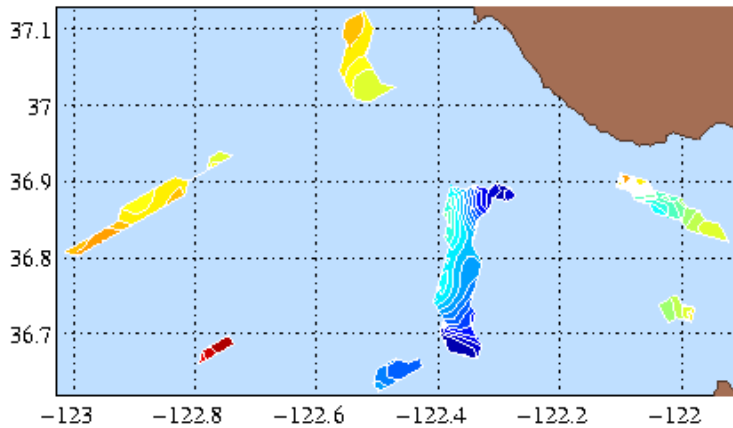

Forecast – Data

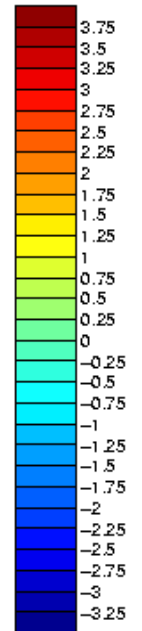
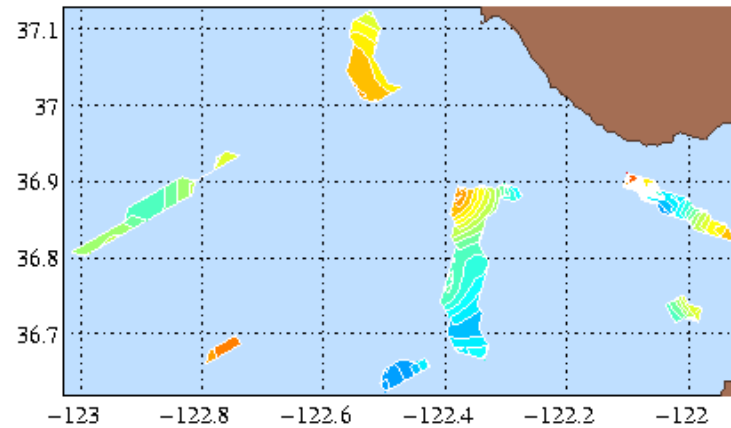

Approaches to Multi-Model Forecasting

ROMS/HOPS re-analysis temperature

vs. M2 temperature at 10 m

By combining the models we attempt to:

1. eliminate systematic errors
2. reduce random errors

We look to solve the problem by employing the utility of neural nets (model errors generally exhibit non-linear evolution). A neural net is a non-linear operator which can be adapted (trained) to approximate a target arbitrary non-linear function. The neural net estimates are contrasted to a linear least-squares fit.

Sigmoidal Transfer Function

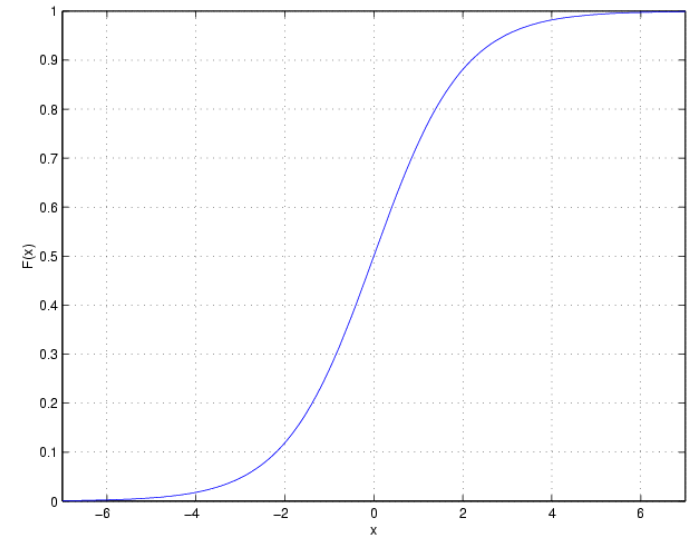

Single Sigmoidal layer:

$$\mathcal{F}\{\mathbf{x}\} = \mathcal{L}_2 \Sigma_1 \mathcal{L}_1\{\mathbf{x}\} = w_{20} + w_{21} \sigma \left(w_{10} + \sum_{k=1}^K w_{1k} x_k \right)$$

Linear least-squares fit:

$$\mathcal{L}\{\mathbf{x}(t)\} = w_0 + \sum_{k=1}^2 w_k x_k(x, y, t)$$

Neural Net Least Squares Fit

Training data	w_{20}	w_{21}	w_{10}	w_H	w_R	rms_{1st}	rms_{2nd}
First half	9.472	11.015	-6.175	0.301	0.121	0.72	1.34
Second half	13.197	10.862	-10.764	0.222	0.372	0.80	1.27

Linear Least Squares Fit

Training data	w_0	w_H	w_R	rms_{1st}	rms_{2nd}
First half	-3.118	0.965	0.277	0.733	1.576
Second half	-2.842	0.478	0.690	0.85	1.35

Equal Weights

	w_1	w_2	rms_1	rms_2
	0.5	0.5	0.79	1.39

Model	rms_{1st}	rms_{2nd}
HOPS	1.28	1.82
ROMS	1.45	1.54

Individual Models

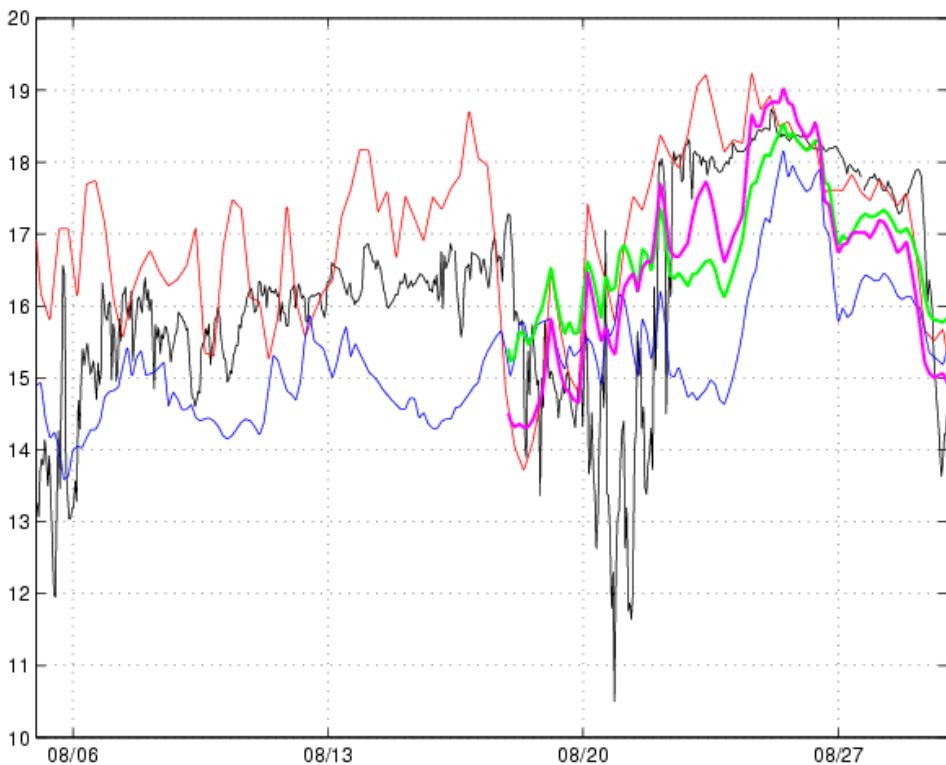
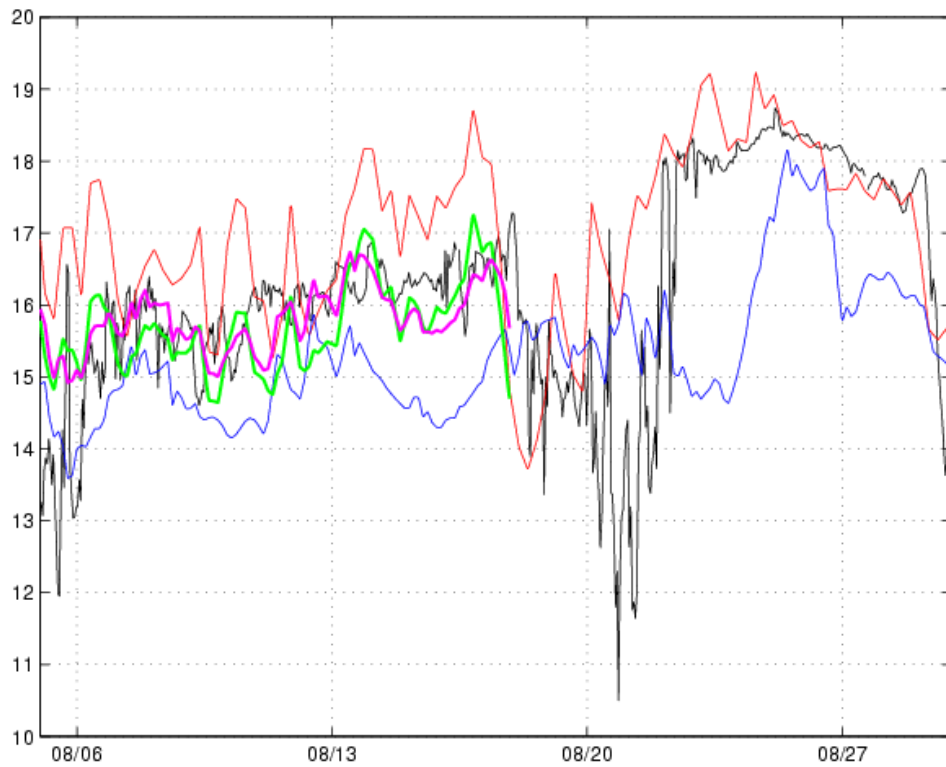

Observed (black) and modeled (red and blue) temperatures at the M2 mooring.

ROMS re-analysis, **HOPS re-analysis**

Top: **Green** – HOPS/ROMS reanalysis combined via neural net trained on the second subset of data (after Aug 17).

Magenta – HOPS/ROMS reanalysis combined via neural net trained on the first subset of data (before Aug 17).

Bottom: **Green** – HOPS/ROMS reanalysis combined via neural net trained on the first subset of data (before Aug 17).

Magenta – HOPS/ROMS reanalysis combined via neural net trained on the second subset of data (after Aug 17).

Multi-Scale Energy and Vorticity Analysis

MS-EVA utilizes multiple scale window decomposition in space and time for the investigation of processes which are:

- multi-scale interactive
- non-linear
- intermittent in space
- episodic in time

Through exploring:

- pattern generation, and
- energy and enstrophy

- transfers
- transports, and
- conversions

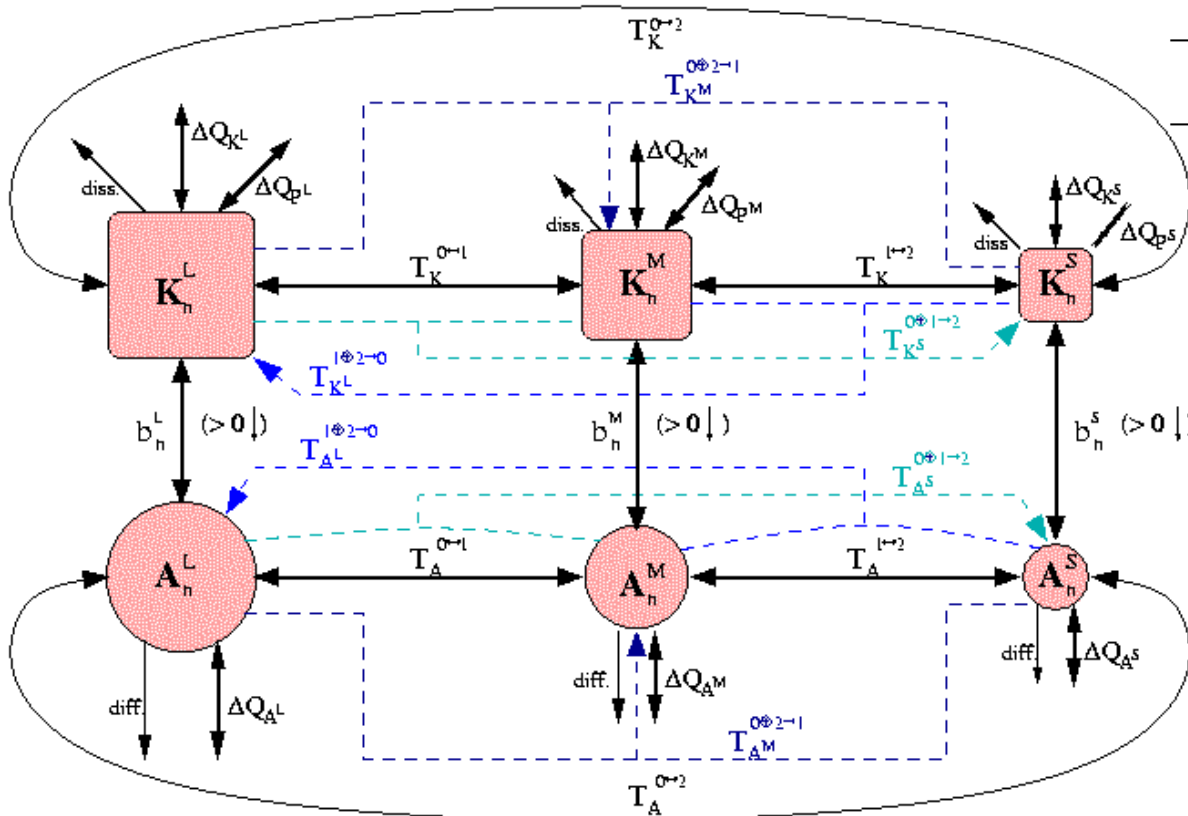

- K:** Kinetic Energy
- A:** Available Potential Energy
- ΔQ:** Transport in physical space
- T:** Transfer in phase space
- b:** Buoyancy Conversion
- L:** Large scale
- M:** Mesoscale
- S:** Sub-mesoscale

Large Scale Energetics During Relaxation Period

Available Potential Energy (APE)

Kinetic Energy (KE)

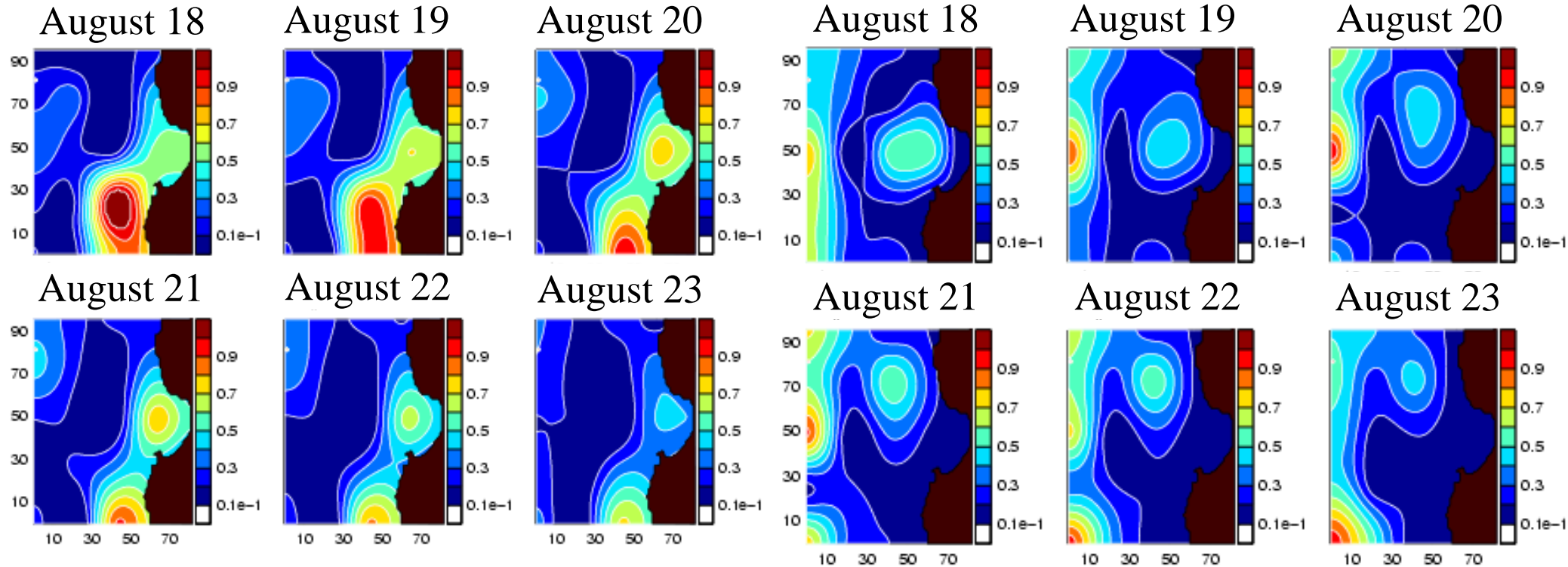

- Both APE and KE decrease during the relaxation period
- Transfer from large-scale window to mesoscale window must take place to account for the decrease in energy

Windows: Large-scale (≥ 8 days; > 30 km), mesoscale (0.5-8 days), and sub-mesoscale (< 0.5 days)

Large-Scale MS-EVA Fields

At start of relaxation

Vertical Mixing

H. Pressure Work

Depth = 10m

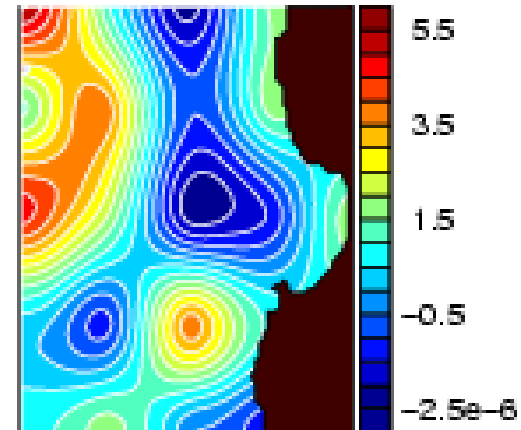
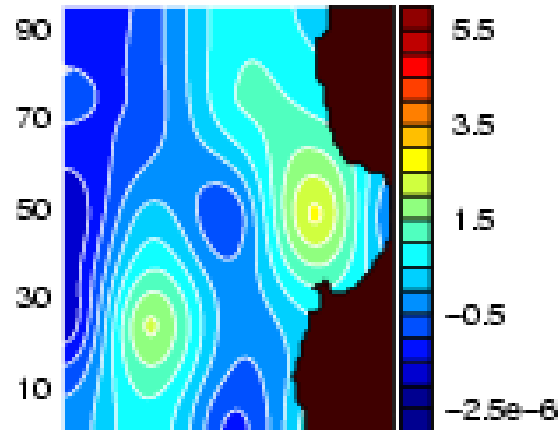

Meso ← Large
Transfer (KE)

Meso ← Large
Transfer (APE)

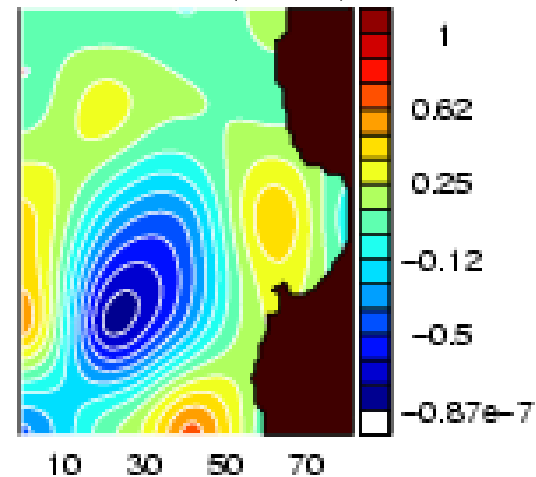
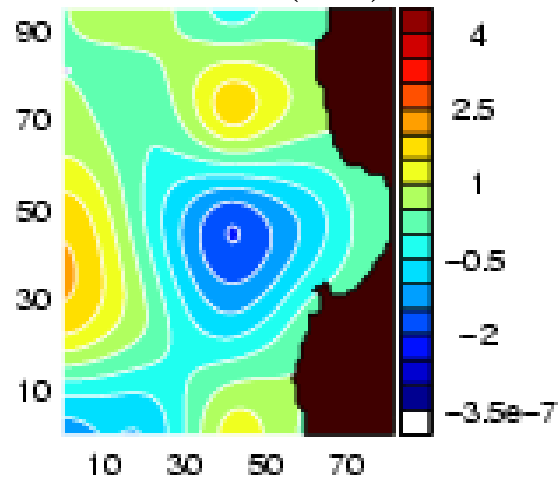

- Balance between vertical mixing (wind stirring) and horizontal pressure working rate
- Transfers of KE and APE from meso-scale to large window are negative \Rightarrow energy is being transferred from large to meso-scale

Modeling of tidal effects in HOPS

- Obtain first estimate of principal tidal constituents via a shallow water model
 1. Global TPXO5 fields (Egbert, Bennett et al.)
 2. Nested regional OTIS inversion using tidal-gauges and TPX05 at open-boundary

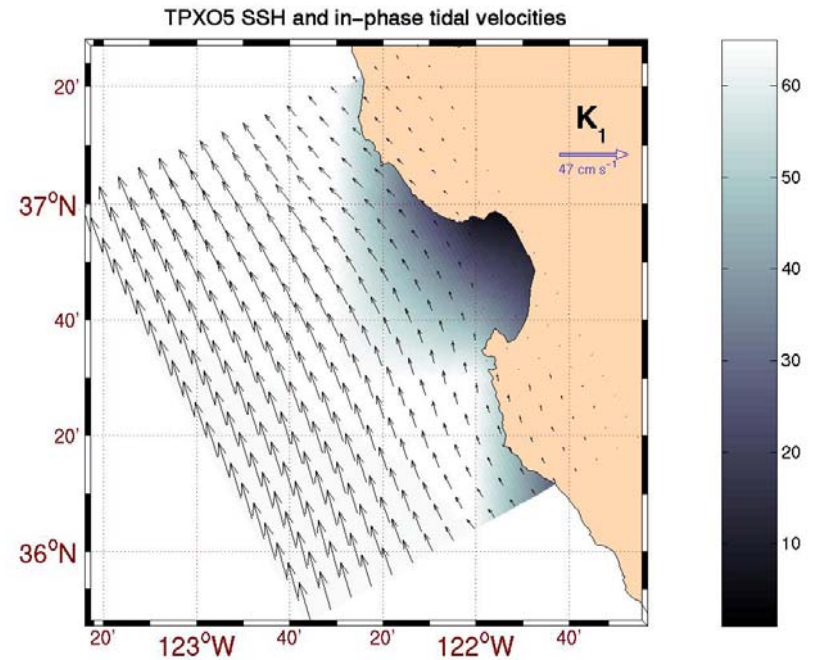
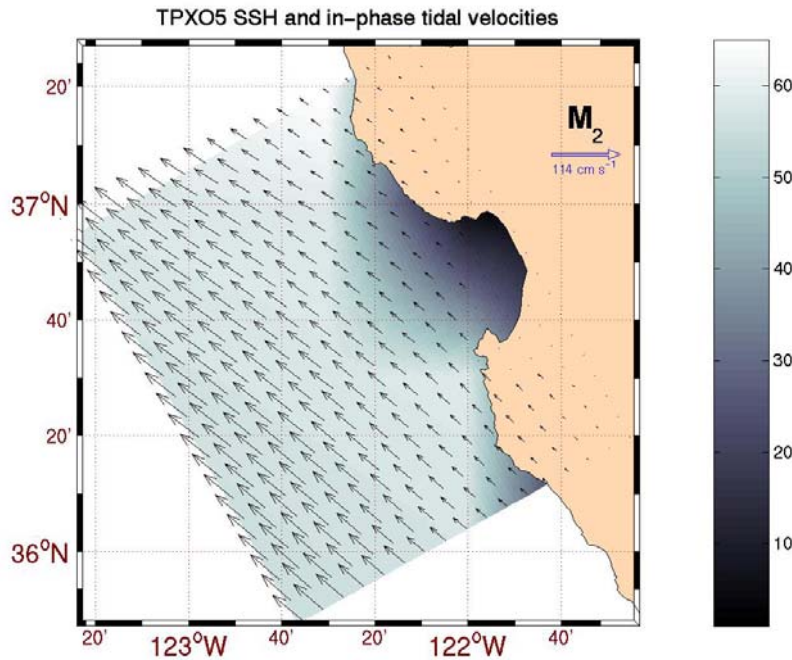

- Used to estimate hierarchy of tidal parameterizations :

i. Vertical tidal Reynolds stresses (diff., visc.)

$$K_T = \alpha \|\mathbf{u}_T\|^2 \quad \text{and} \quad K = \max(K_S, K_T)$$

ii. Modification of bottom stress

$$\tau = C_D \|\mathbf{u}_{S+} \mathbf{u}_T\| \mathbf{u}_S$$

iii. Horiz. momentum tidal Reyn. stresses

Σ_ω (Reyn. stresses averaged over own T_ω)

iv. Horiz. tidal advection of tracers

1/2 free surface

v. Forcing for free-surface HOPS

full free surface

Two 6-day model runs

No-tides

Temp. at 10 m

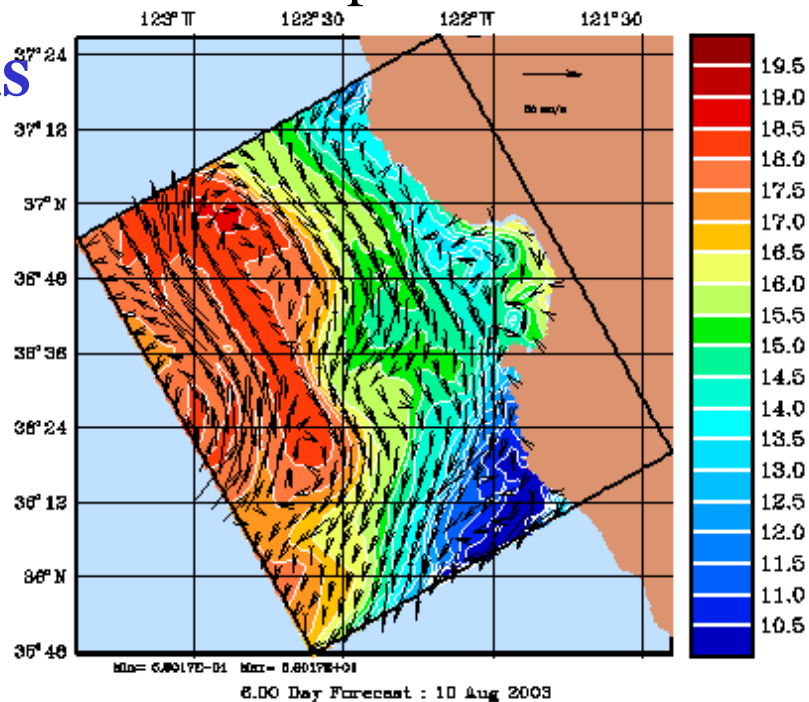

T section across Monterey-Bay

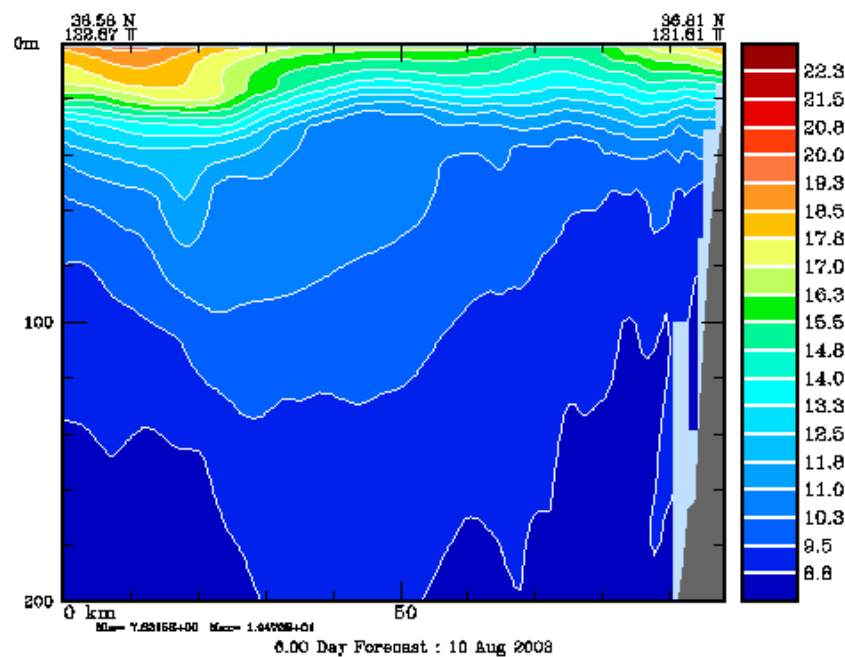

Tidal effects

- Vert. Reyn.
- Stress
- Horiz. Momentum Stress

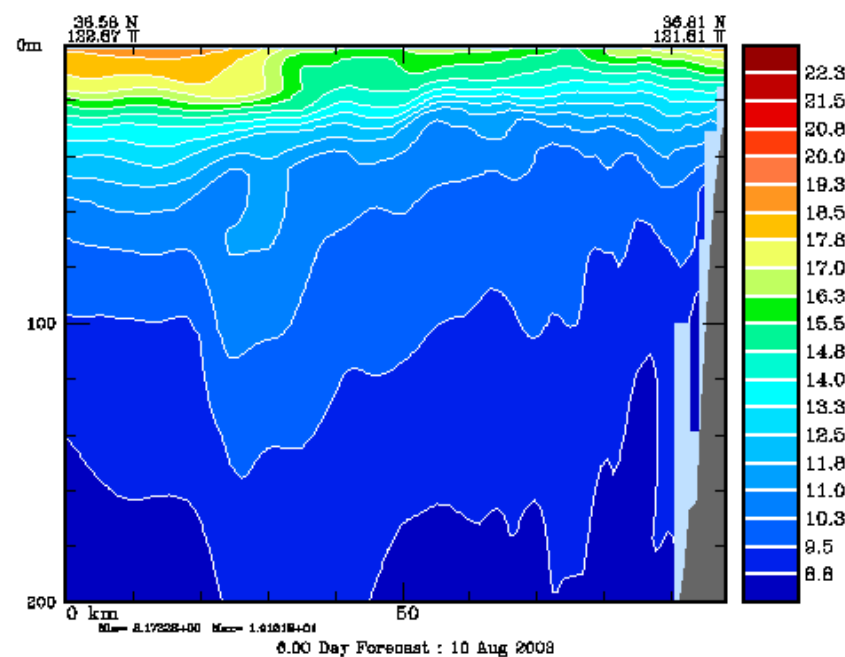
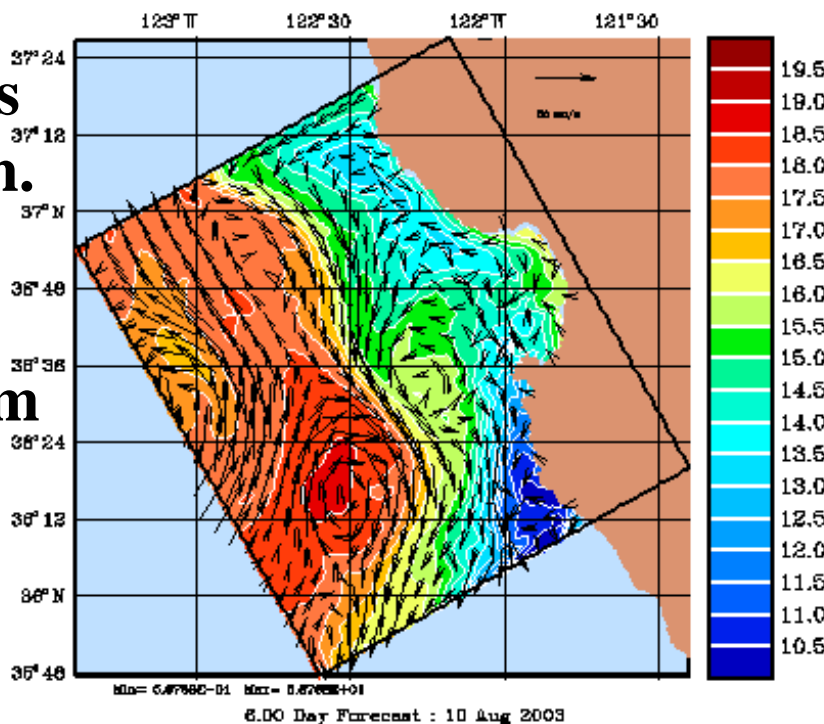

Post-Cruise Surface CHL forecast (Hindcast)

- Starts from zeroth-order dynamically balanced IC on Aug 4
- Then, 13 days of physical DA
- Forecast of 3-3-5 days afterwards

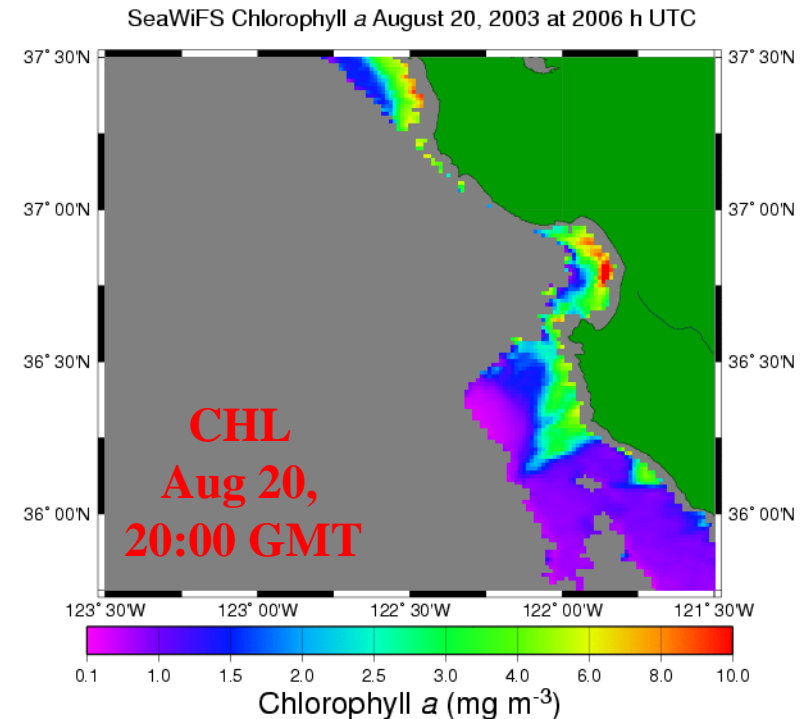
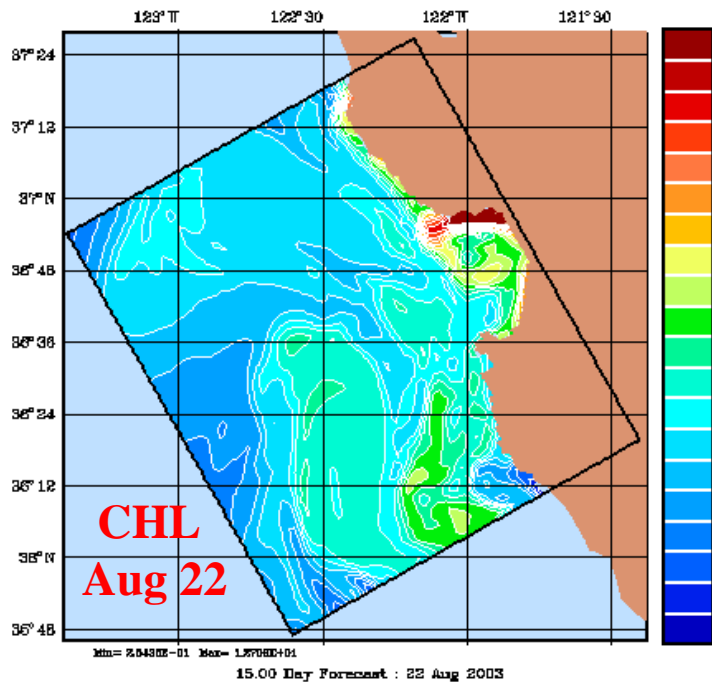
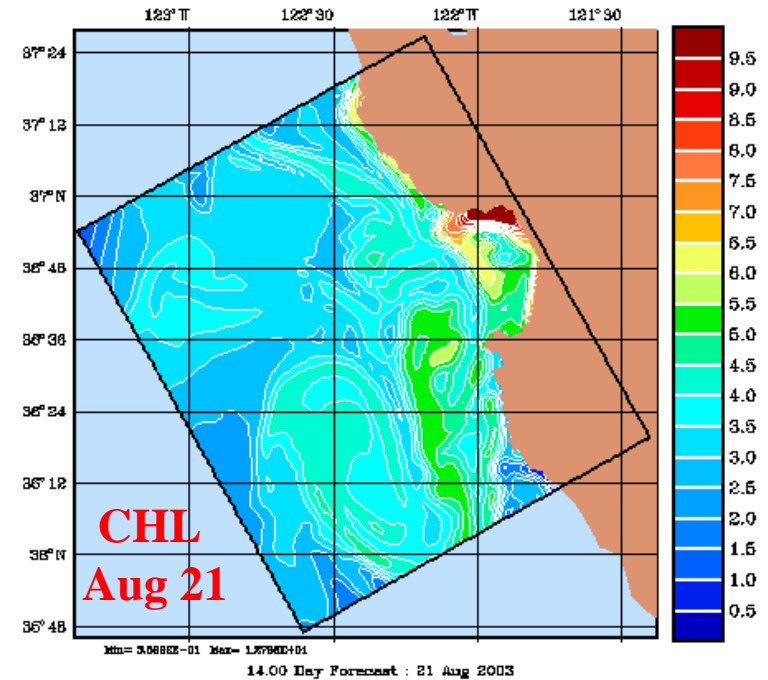
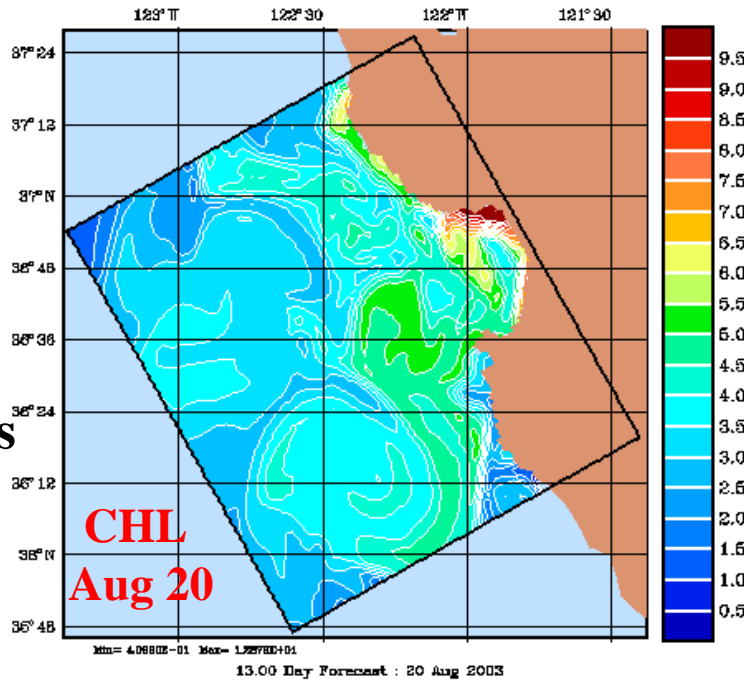

Error Subspace Statistical Estimation (ESSE)

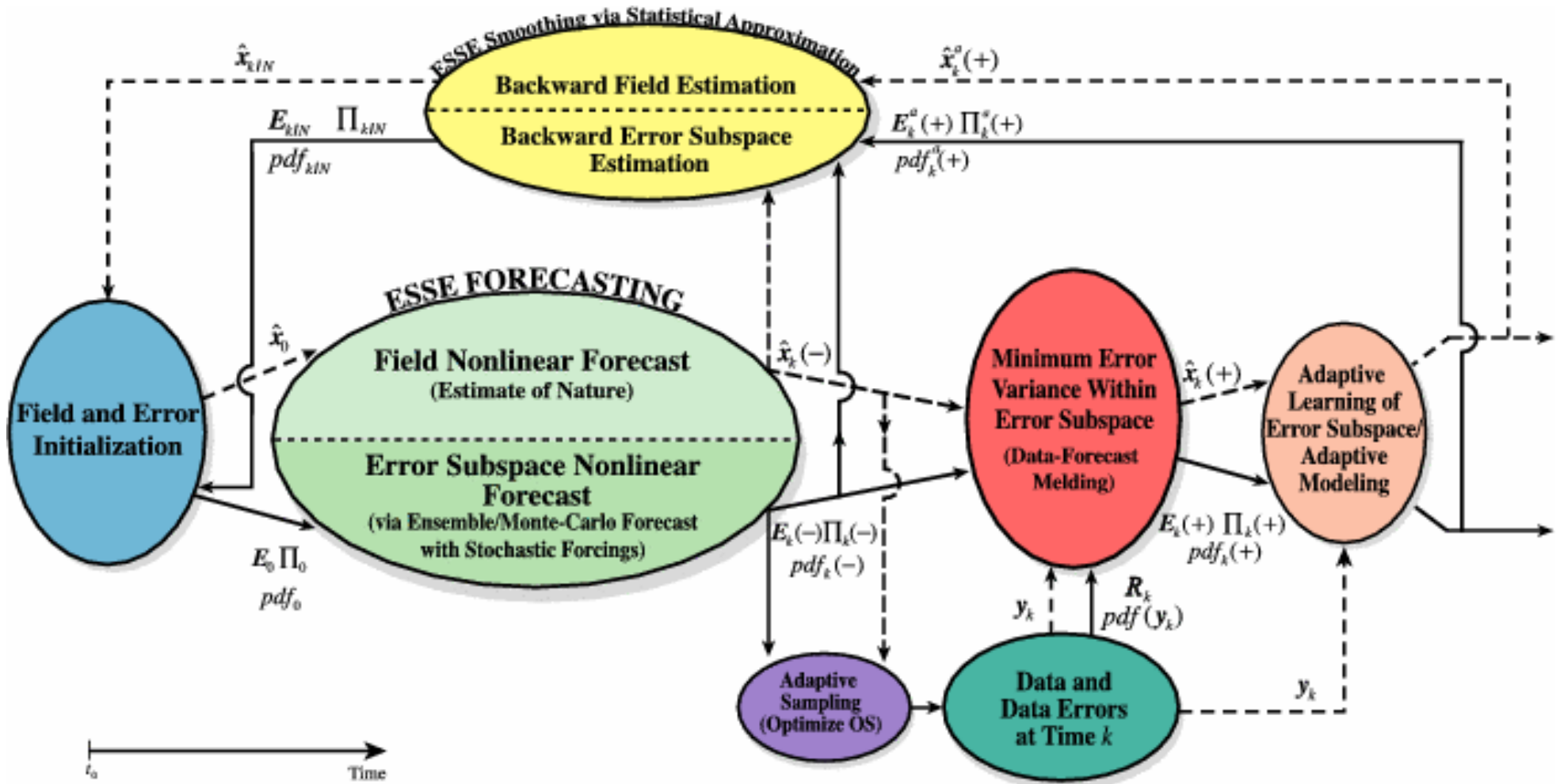

- Uncertainty forecasts (dynamic error subspace and adaptive error learning)
- Ensemble-based (with nonlinear and stochastic model)
- Multivariate, non-homogeneous and non-isotropic DA
- Consistent DA and adaptive sampling schemes
- Software: not tied to any model, but specifics currently tailored to HOPS

Real-time ESSE : AOSN-II Accomplishments

- 10 sets of ESSE nowcasts and forecasts of temperature, salinity and velocity, and their uncertainties, issued from 4 Aug. to 3 Sep.
 - Total of 4323 ensemble members: 270 – 500 members per day (7×10^5 state var.)
 - ESSE fields included: central forecasts, ensemble means, *a priori* (forecast) errors, *a posteriori* errors, dominant singular vectors and covariance fields
 - 10^4 data points quality controlled and assimilated per day: ship (Pt. Sur, Martin, Pt. Lobos), glider (WHOI and Scripps) and aircraft SST data
- Ensemble of stochastic PE model predictions (HOPS)
 - Deterministic atmospheric forcing: 3km and hourly COAMPS flux predictions
 - Stochastic oceanic/atmos. forcings for: sub-mesoscale eddies, BCs and atmos. fluxes
- ESSE fields formed the basis for daily adaptive sampling recommendations
- Adaptive ocean modeling: BCs and model parameters for transfer of atmos. fluxes calibrated and modified in real-time to adapt to evolving conditions
- ESSE results described and posted on the Web daily
- Real-time research: stochastic error models, coupled physics-biology, tides

Aug 12: Initial Conditions

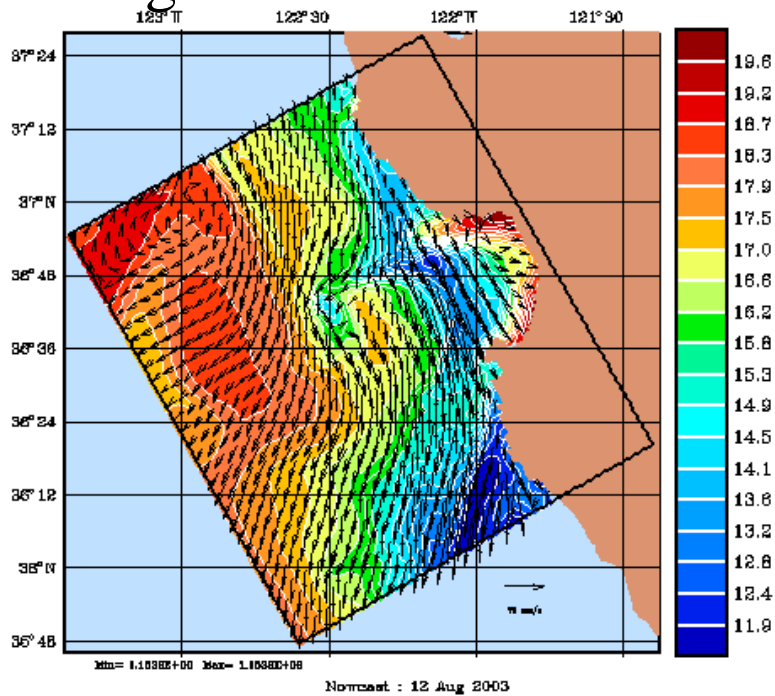

Aug 14: 2-day, central fct.

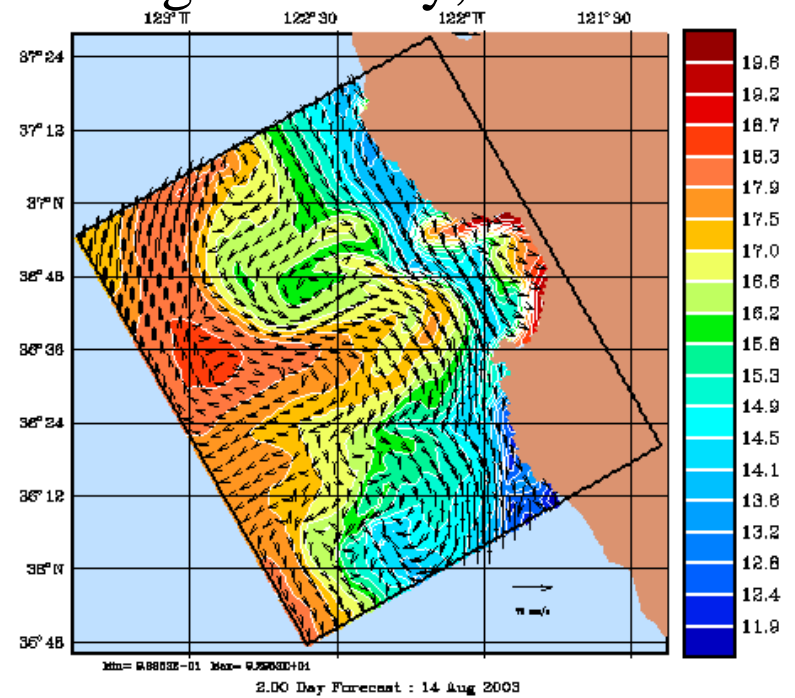

Aug 14: 2-day fct., ens mean

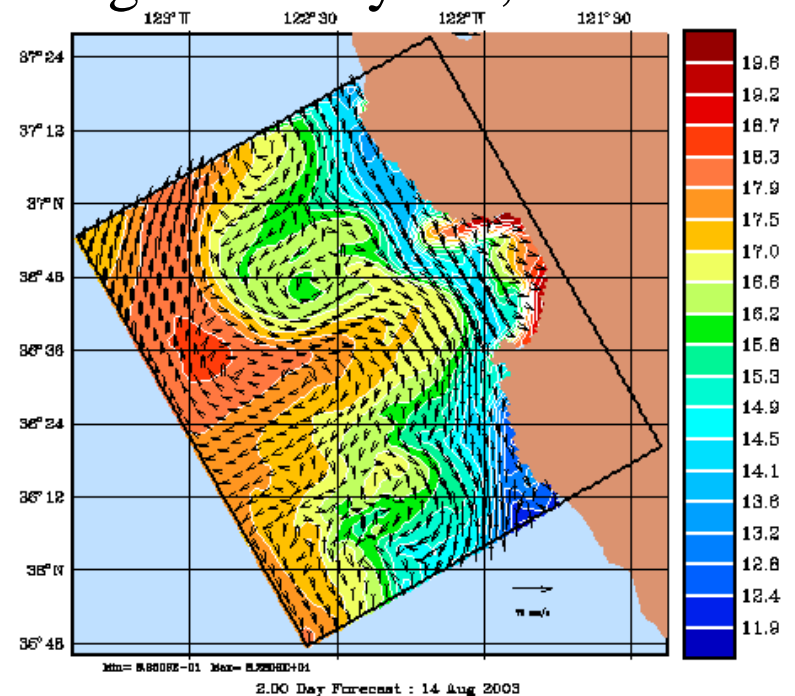

**Sample ESSE Products:
Ensemble Mean and Central Forecast
Issued in real-time**

RMSE Estimate

Standard deviations of horizontally-averaged data-model differences

Data Composite for Aug 13

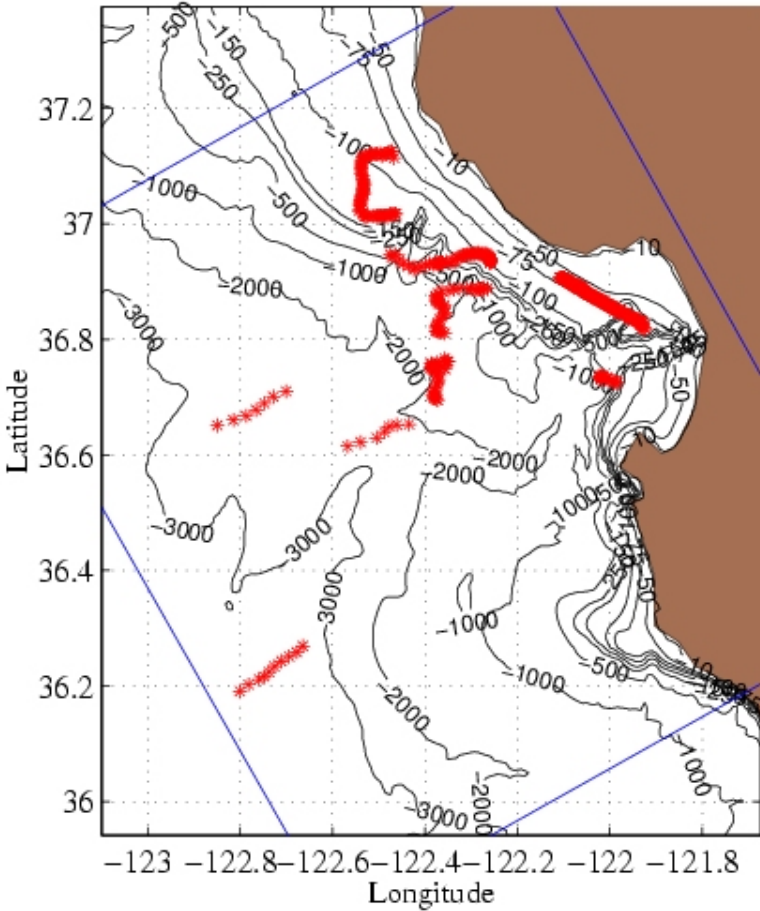

Verification data time: Aug 13
All forecasts are compared to this Aug 13 data

Std of Data-Model Temp at data pts

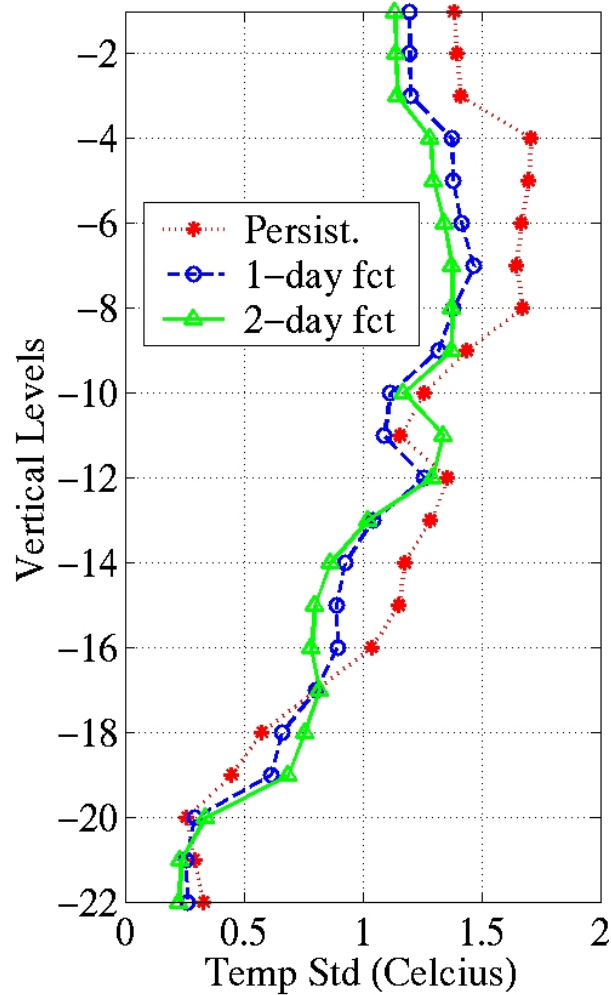

Std of Data-Model Sal at data pts

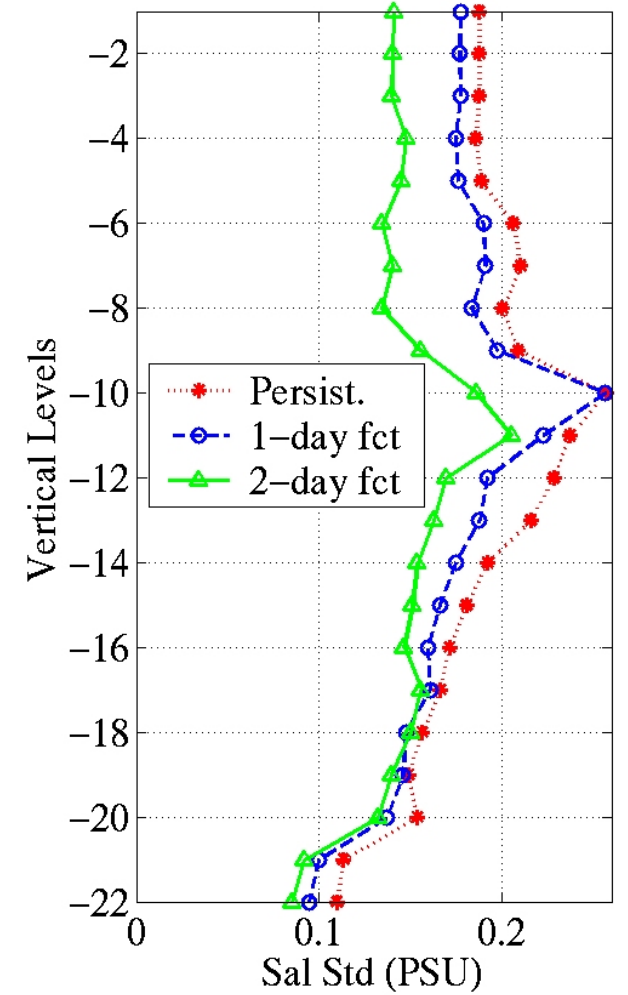

Nowcast: Aug 11 (persistence forecast, red)
2-day forecast for Aug 13 (green)
1-day forecast for Aug 12 (blue, to check phase error)

Bias Estimate

Horizontally-averaged data-model differences

Data Composite for Aug 13

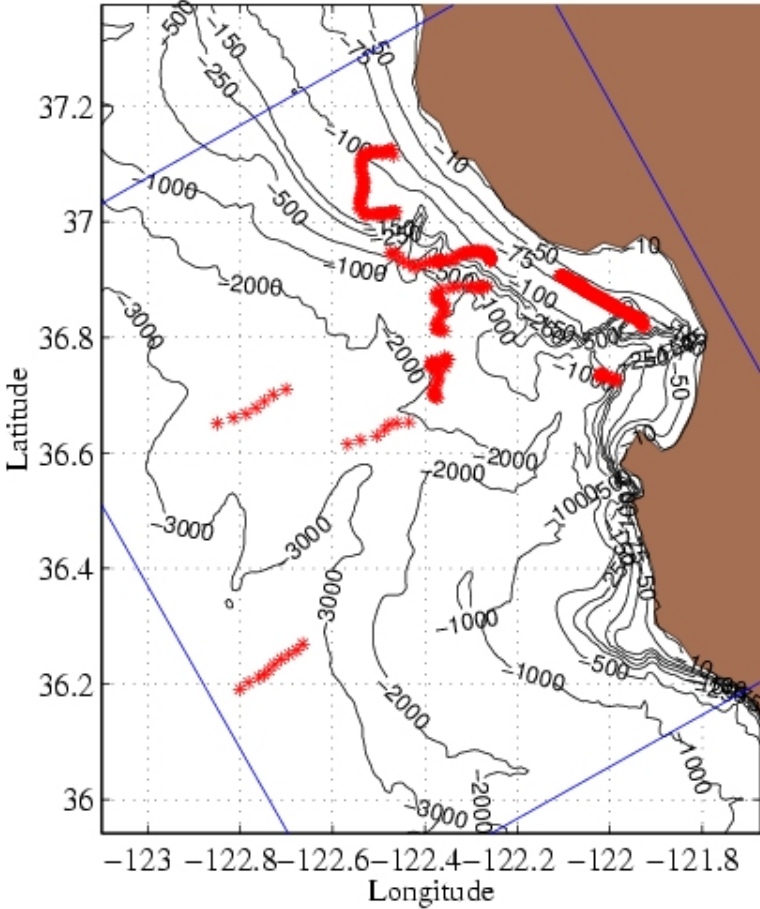

Verification data time: Aug 13
All forecasts are compared to this Aug 13 data

Mean of Data-Model Temp at data pts

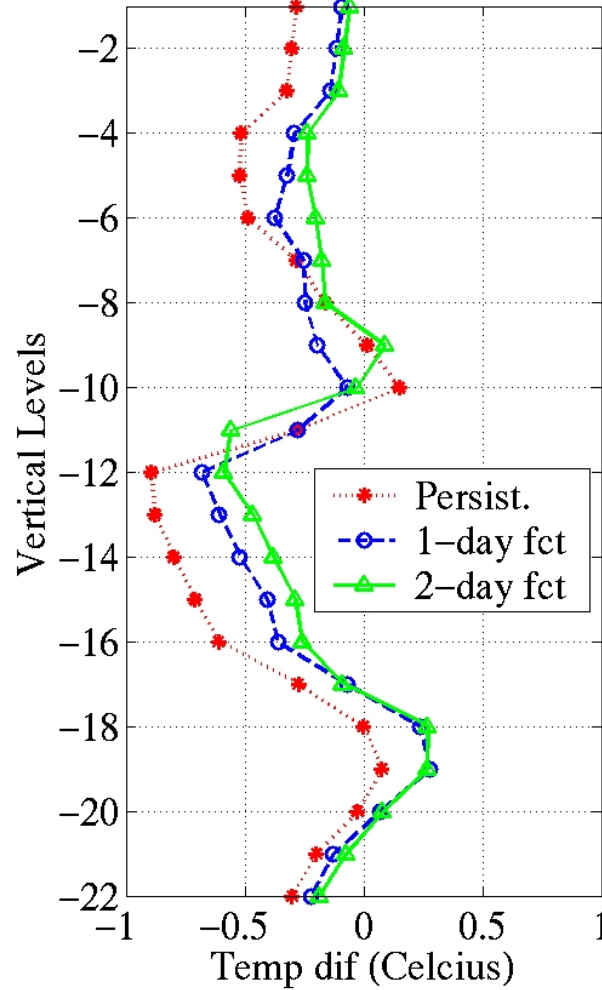

Mean of Data-Model Sal at data pts

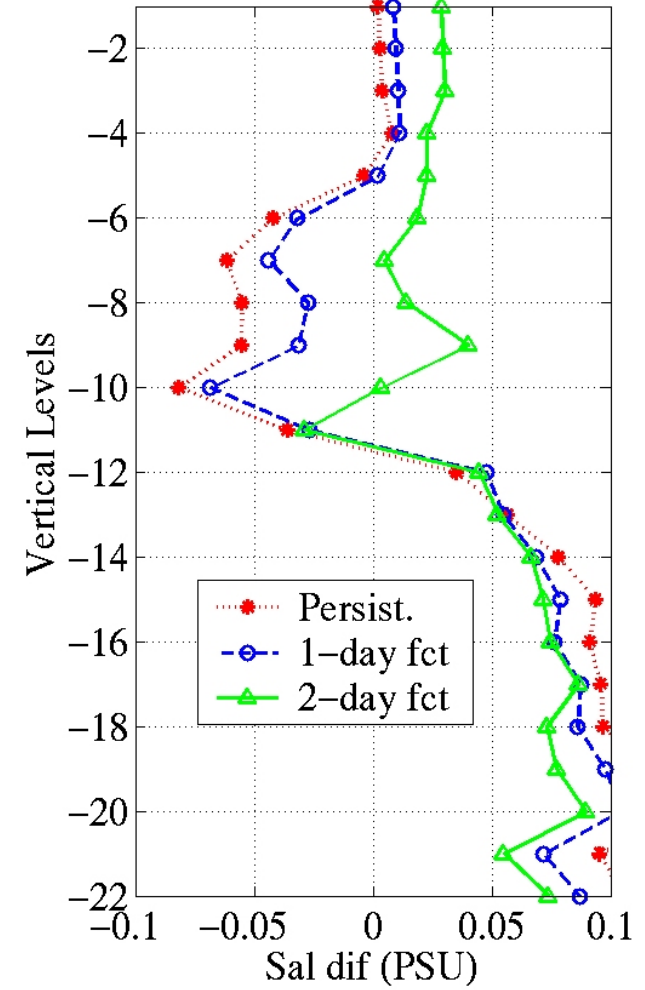

Nowcast: Aug 11 (persistence forecast, red)
2-day forecast for Aug 13 (green)
1-day forecast for Aug 12 (blue, to check phase error)

ESSE Surface Temperature Error Standard Deviation Forecasts

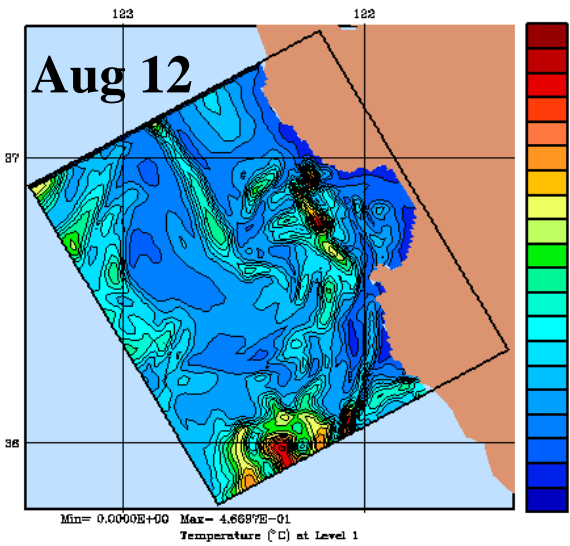

Start of Upwelling

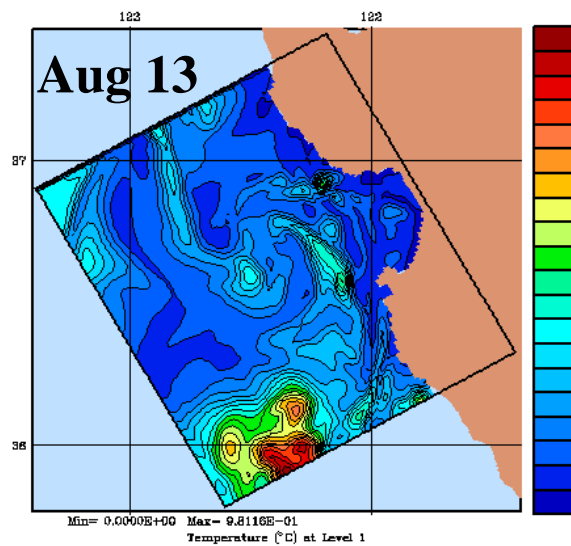

First Upwelling period

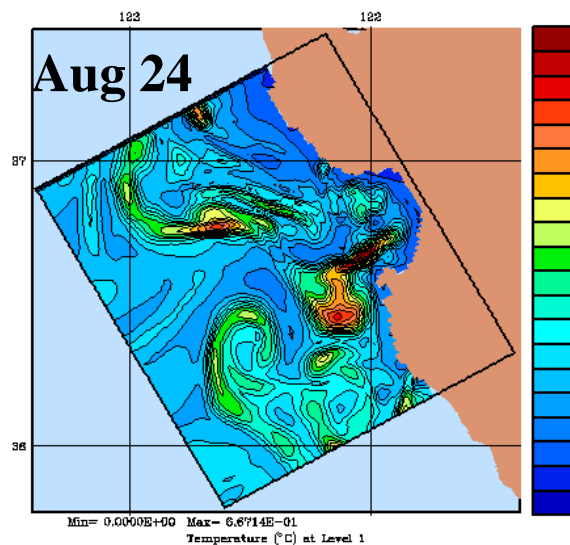
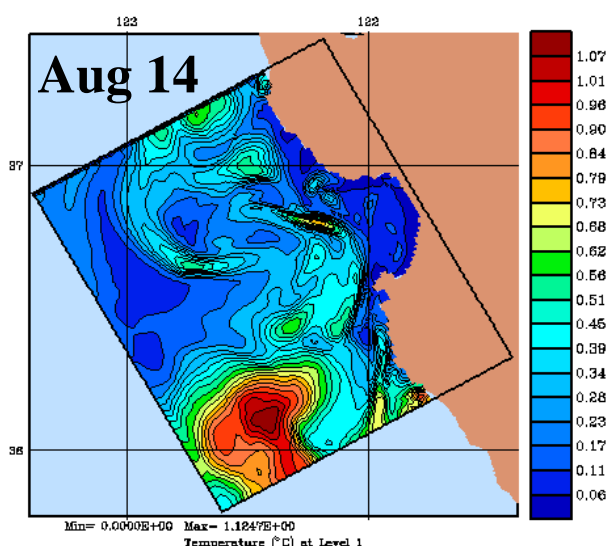

End of Relaxation

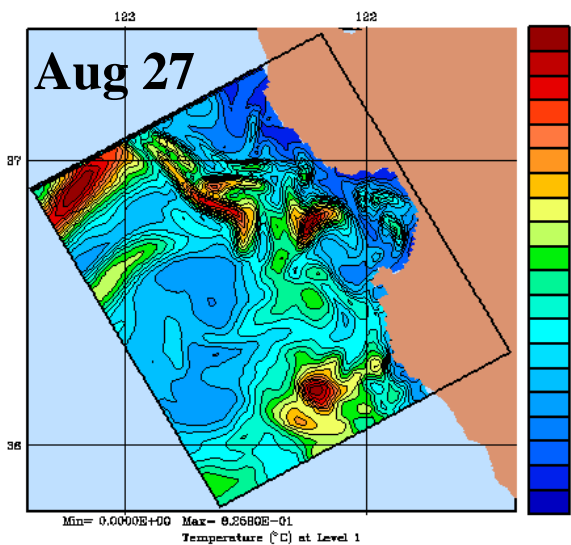

Second Upwelling period

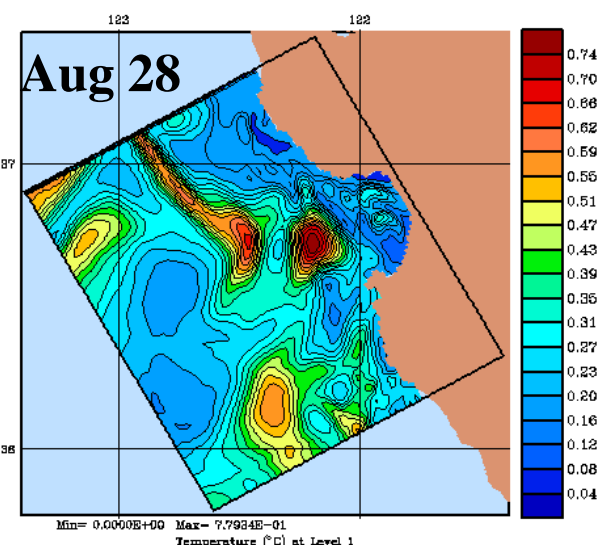

ESSE DA properties: Error covariance function predicted for 28 August

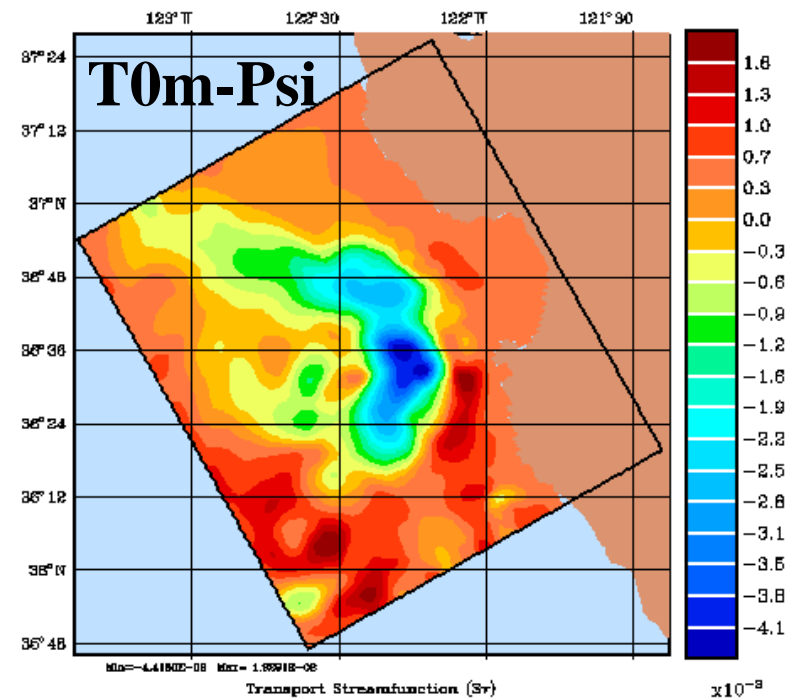
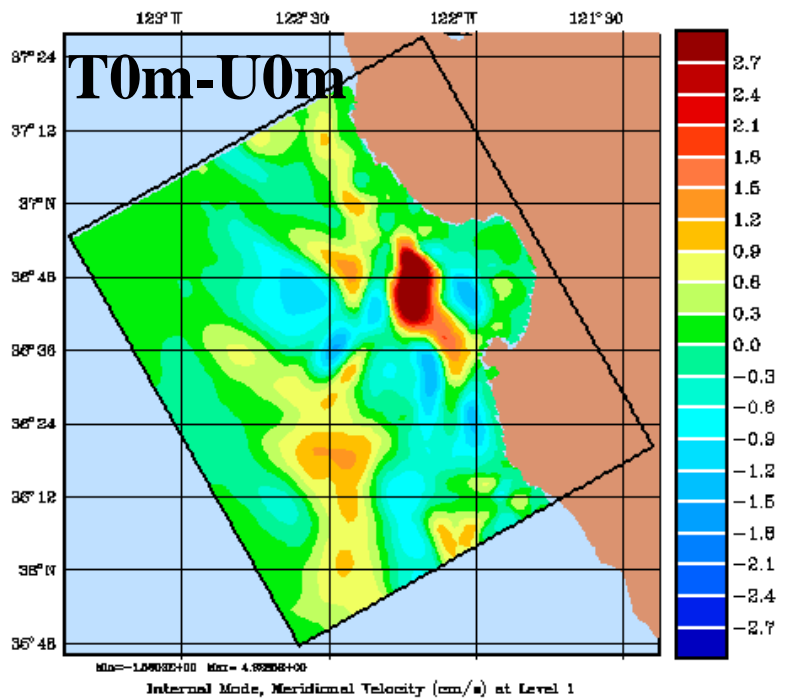
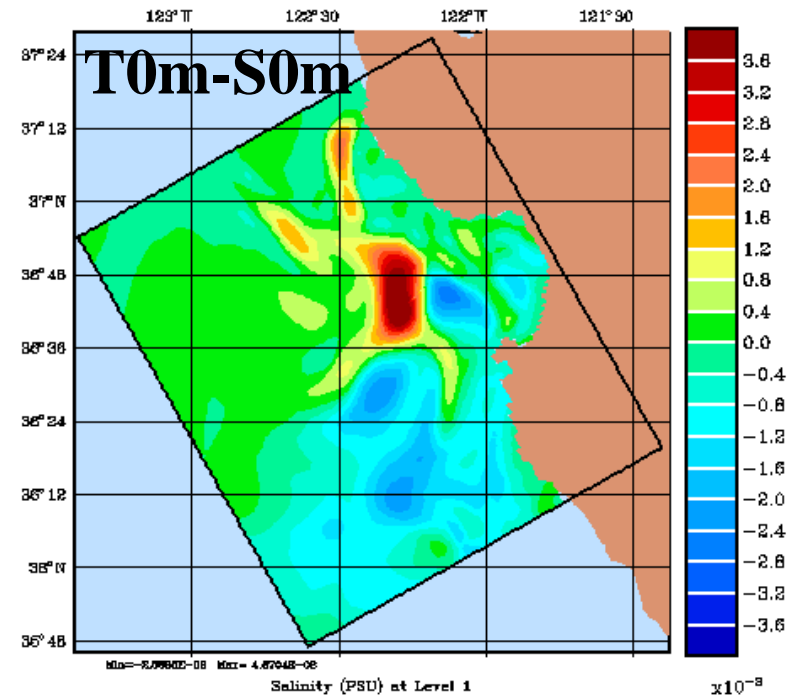
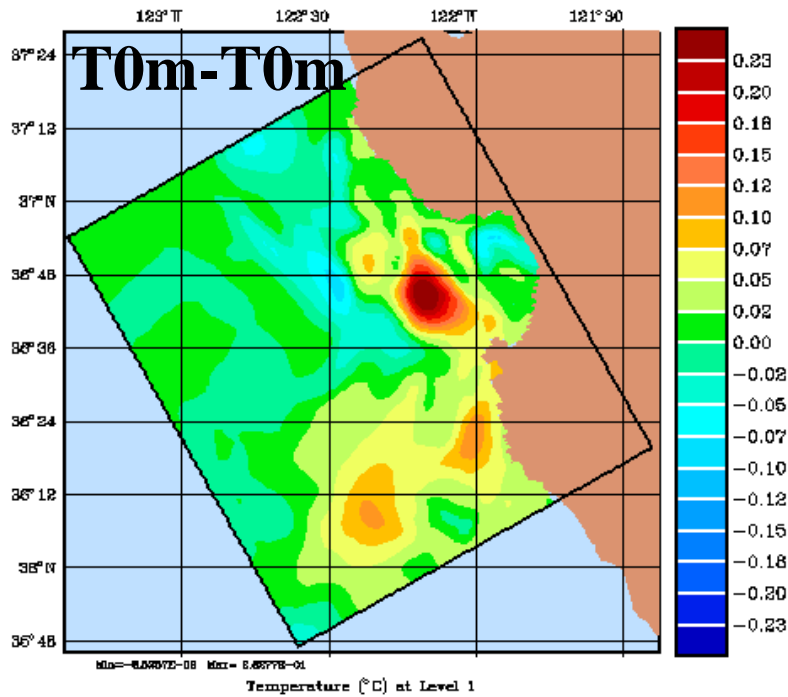

Adaptive sampling schemes via ESSE

Adaptive Sampling: Use forecasts and their uncertainties to predict the most useful observation system in space (locations/paths) and time (frequencies)

$$\begin{array}{lll} \text{Dynamics:} & dx = M(x)dt + d\eta & \eta \sim N(0, Q) \\ \text{Measurement:} & y = H(x) + \varepsilon & \varepsilon \sim N(0, R) \end{array}$$

Non-lin. Err. Cov.:

$$dP/dt = \langle (x - \hat{x})(M(x) - M(\hat{x}))^T \rangle + \langle (M(x) - M(\hat{x}))(x - \hat{x})^T \rangle + Q$$

Metric or Cost function: e.g. Find H_i and R_i such that

$$\underset{H_i R_i}{\text{Min}} \text{tr}(P(t_f)) \quad \text{or} \quad \underset{H_i R_i}{\text{Min}} \int_{t_0}^{t_f} \text{tr}(P(t)) dt$$

Real-time Adaptive Sampling – R/V Pt. Lobos

- 25 Aug forecast: Large uncertainty for 26 Aug. related to predicted meander of the coastal current which advects warm and fresh waters towards Monterey Bay Peninsula.
- Position and strength of meander were very uncertain (e.g. T and S error St. Dev., based on 450 2-day fcsts.).
- Different ensemble members showed that the meander could be very weak (almost not present) or further north than in the central forecast
- Sampling plan designed to investigate position and strength of meander and region of high forecast uncertainty.

Salinity Error Fcst. for Aug 26

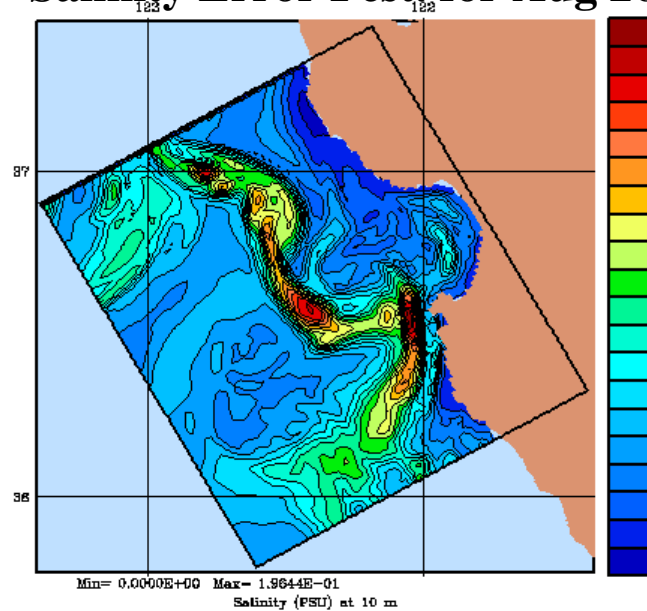

Surf. Temp. Fcst. for Aug 26

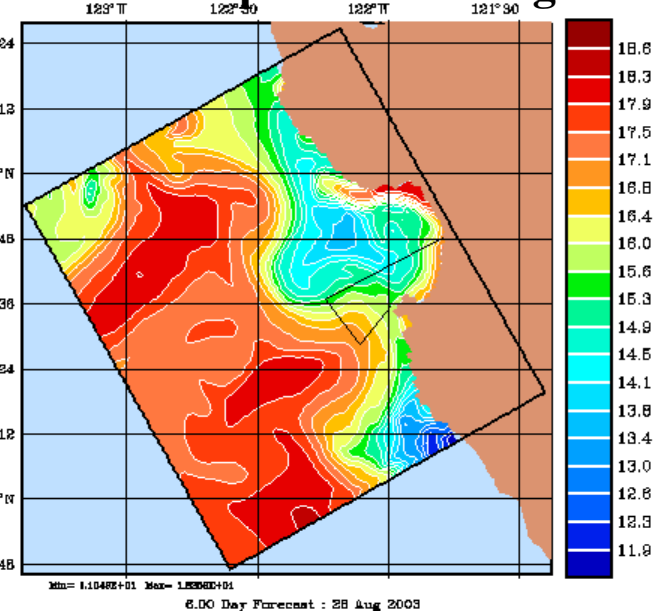

MB Temp. Error Fcst.

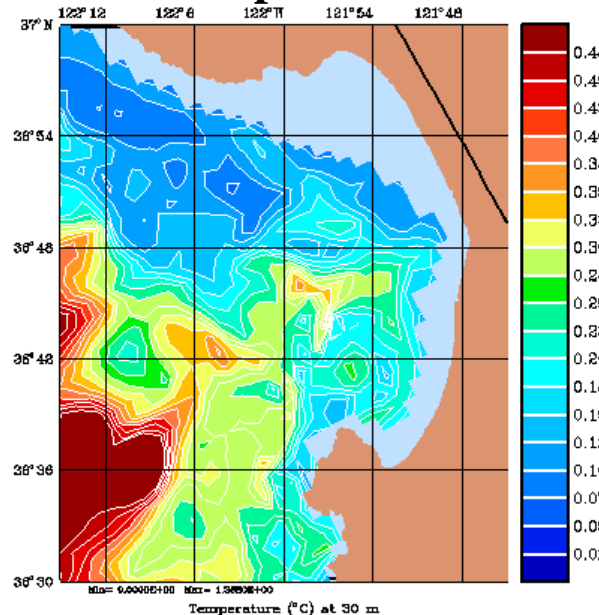

R/V Pt Lobos track for Aug 26

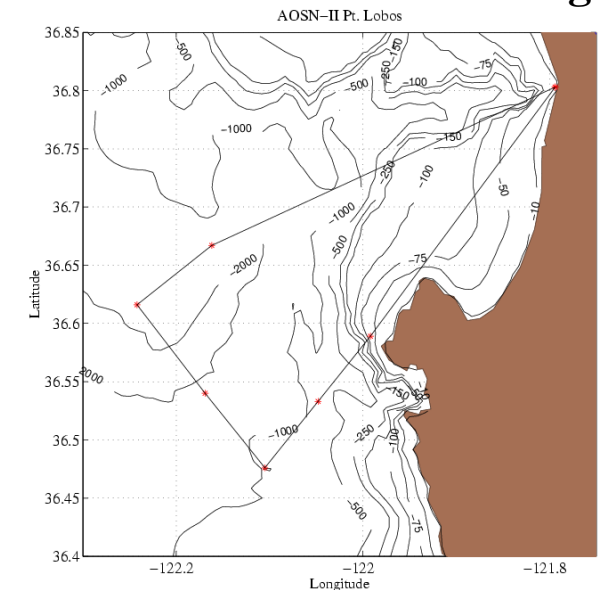

Assimilation of R/V Pt Lobos data damps meander and reduces errors

Real-time Temp 2.5 day Fcst for Aug 26

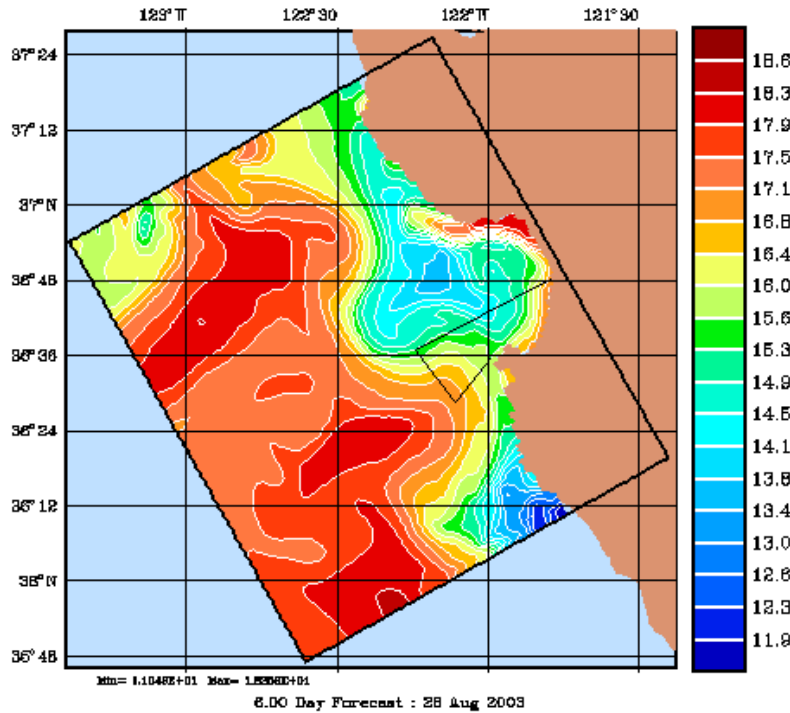

Same but hindcast with DA of re-calibrated data for Aug 20-23

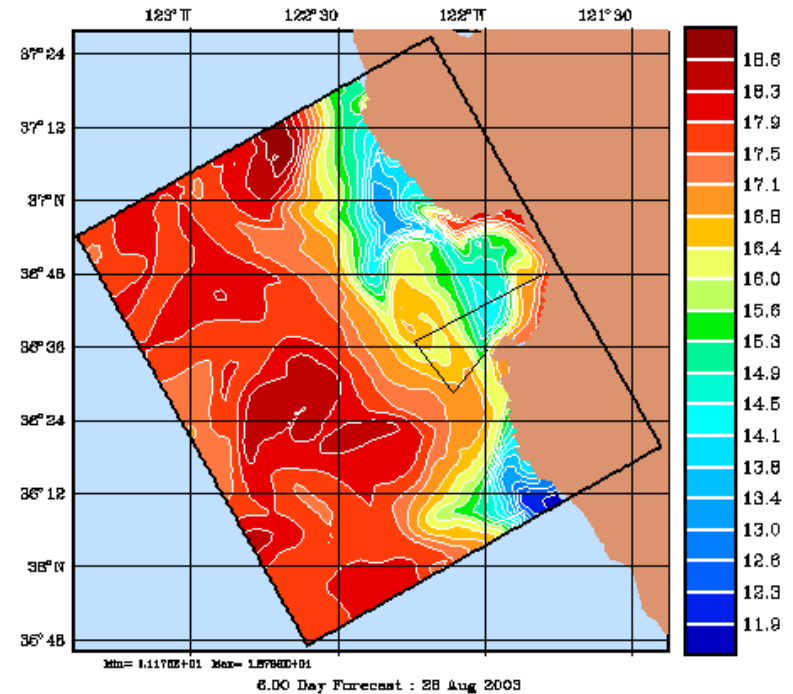

Assimilation of Pt Lobos data substantially weakened the meander

In fact, a hindcast without Pt Lobos but with re-calibrated glider data for Aug 20-23 also weakened the meander and reduced the strength of associate errors

Quantitative Adaptive Sampling via ESSE

- Use exact nonlinear error covariance evolution
 - For every choice of adaptive strategy, an ensemble is computed
1. Select sets of candidate sampling paths/regions and variables that satisfy operational constraints
 2. Forecast reduction of errors for each set based on a tree structure of small ensembles and data assimilation.
 3. Optimization of sampling plan: select sequence of paths/regions and variables which maximize the nonlinear error reduction at t_f (trace of ``information matrix'' at final time) or over $[t_0, t_f]$ in the spatial domain of interest.
- Outputs:
- Maps of predicted error reduction for each sampling paths/regions
 - Information (summary) maps: assigns to the location of each sampling region/path the average error reduction over domain of interest
 - Ideal sequence of paths/regions and variables to sample

Which sampling on Aug 26 optimally reduces uncertainties on Aug 27?

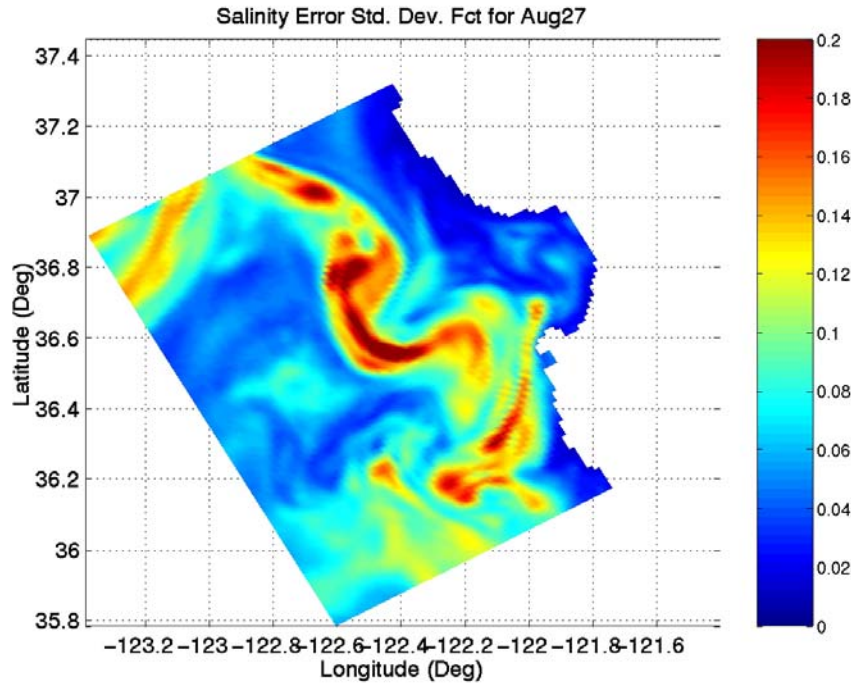

4 candidate tracks, overlaid on surface T fct for Aug 26

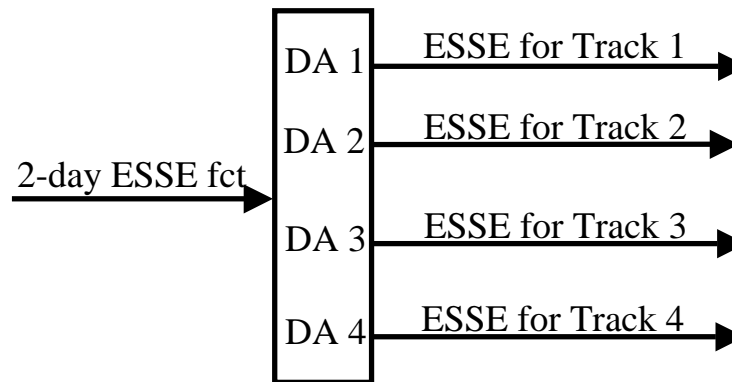
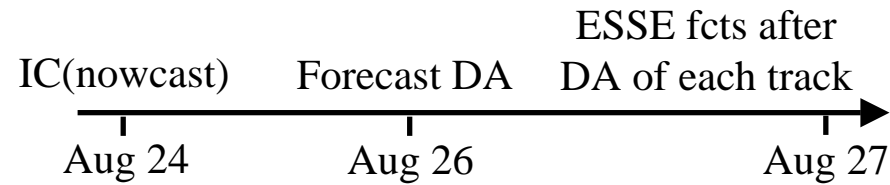
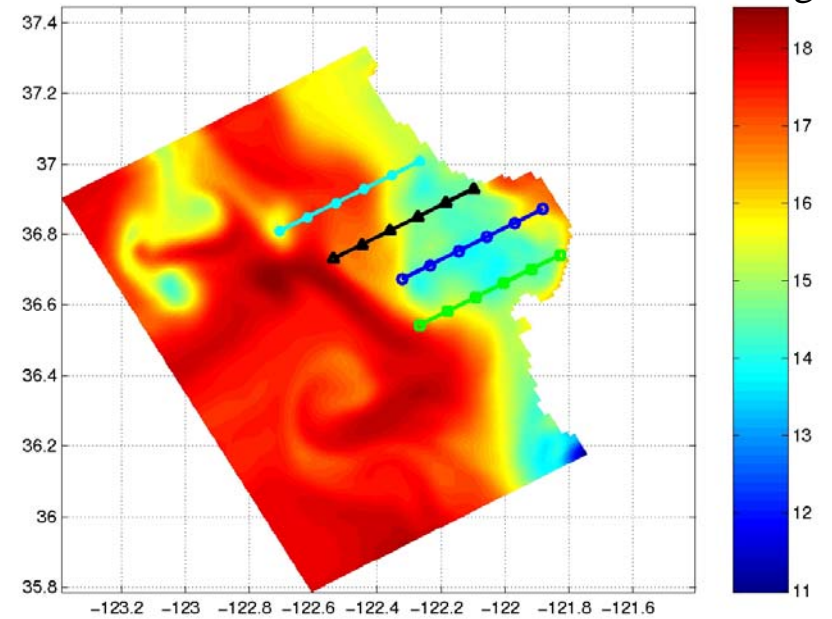

Which sampling on Aug 26 optimally reduces uncertainties on Aug 27?

1. Define relative error reduction as: $(\sigma_{27} - \sigma_{27}^{\text{track } i}) / \sigma_{27}$for $\sigma_{27} > \sigma_{\text{noise}}$
0.....for $\sigma_{27} \leq \sigma_{\text{noise}}$
2. Create relative error reduction maps for each sampling tracks, e.g.:

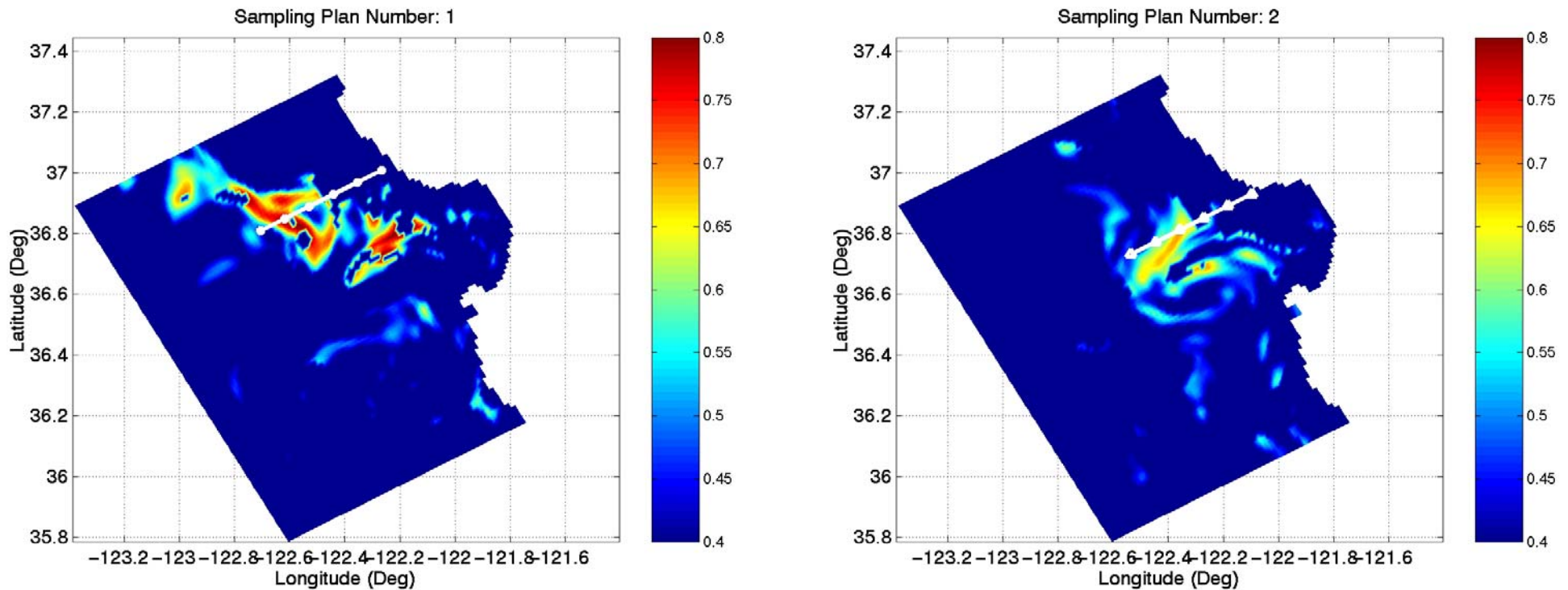

3. Compute average over domain of interest for each variable, e.g. for full domain:
Best to worst error reduction: Track 1 (18%), Pt Lobos (17%),, Track 3 (6%)
4. Create “Aug 26 information map”: indicates where to sample on Aug 26 for optimal error reduction on Aug 27

HOPS - ESSE AOSN-II Conclusions

- **AOSN 2003 Real-time:**
 - **Daily HOPS forecasts of 3 days duration assimilated data from two fleets of gliders, aircraft, ships, etc. and identified features for adaptive sampling (Aug 6-Sep 3)**
 - **Fully nonlinear ESSE carried-out consistent: ensemble forecast of fields and errors, Data assimilation, Adaptive sampling and Dynamical analyses**
 - **Onset and sustained upwelling and relaxation phenomena were successfully captured, together with their dynamic mesoscale variabilities and their impacts on uncertainties**
 - **Preliminary evaluations of real-time forecasts indicate generally good RMS/Bias values that beat persistence**
- **Multi-scale dynamical analyses indicate that during relaxation, large-scale energies decrease and mesoscale energies increase via transfer process**
- **Combined HOPS-ROMS model estimates trained via neural networks yields an estimate with less error than each**
- **Tidal effects introduce smaller scales and alter mesoscale features**
- **Hindcast quantitative adaptive sampling forecasts optimal error reduction**
- **Ongoing research includes:**
 - **Re-analysis fields, descriptive dynamics, methods for skill determination and error models, Coupled physical-biological estimation, Predictability studies**

EXTRA VUGRAFS



Harvard Ocean Prediction System - HOPS

A Generic, Relocatable, Regional Forecast System

Multivariate Coupled Physical-Acoustical-Biological System

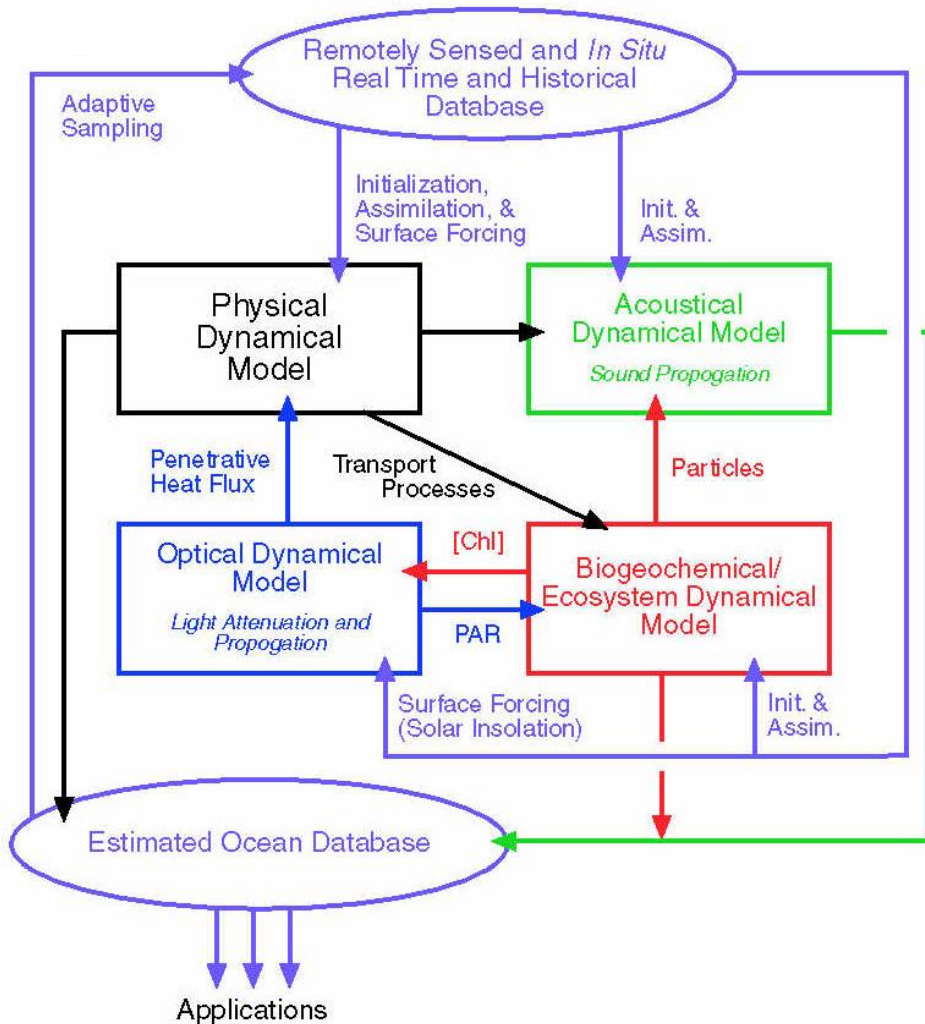

Data Assimilation: combines model and data for best ocean estimate: optimal interpolation (OI) or

Error Subspace Statistical Estimation (ESSE)

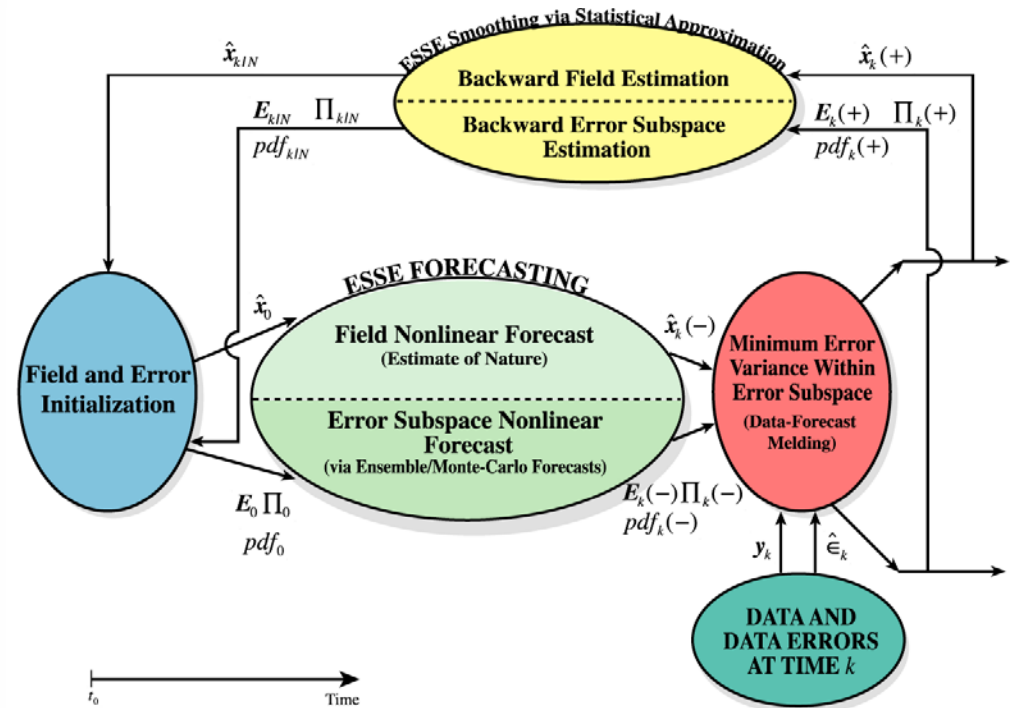

Atmospheric fluxes from 3km and hourly COAMPS (J. Doyle, NRL): Winds

Sensitivity to horizontal resolution

3km improves Representation of Coastal Jets & Coastal Shear Zone

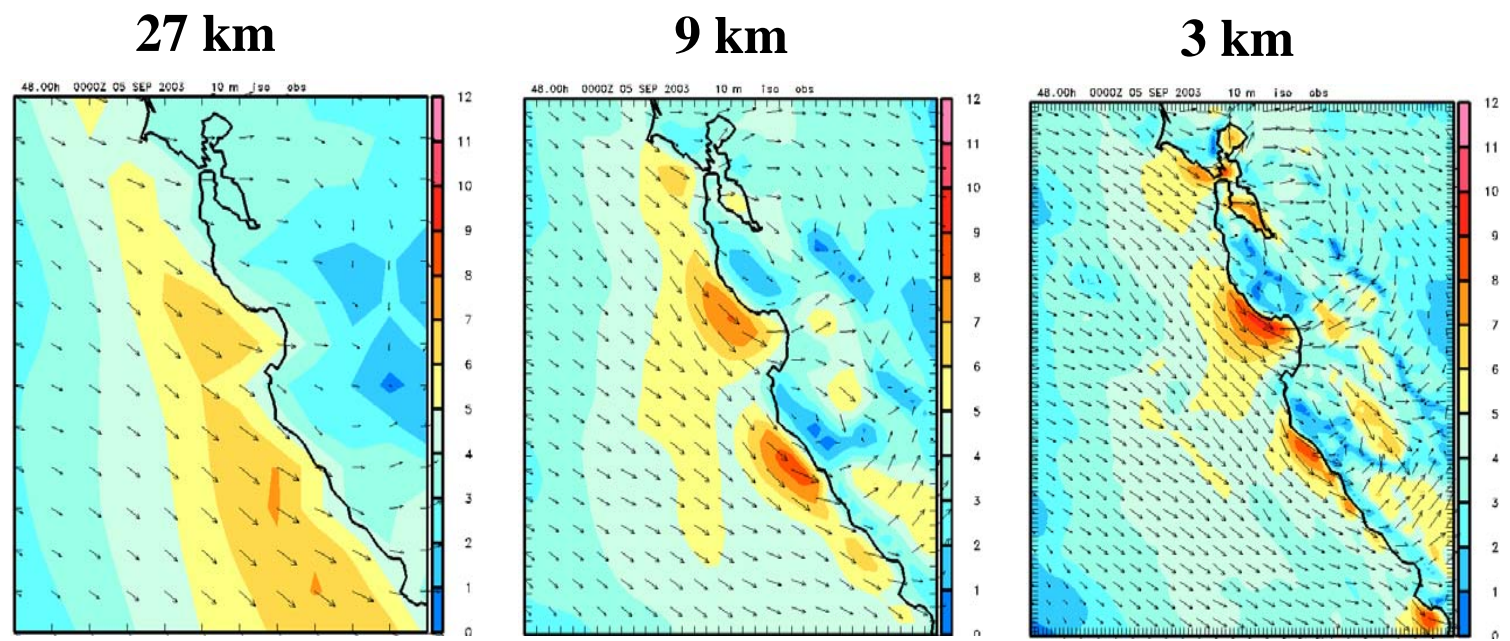

Our evaluations: e.g. Buoy winds (blue) vs. COAMPS 72h forecasts (red dots)

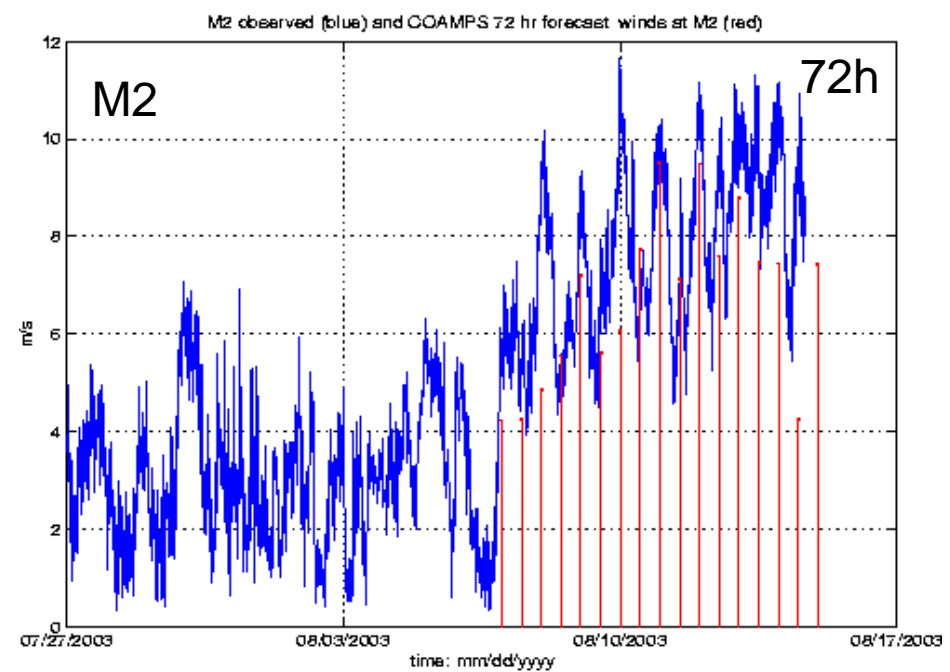
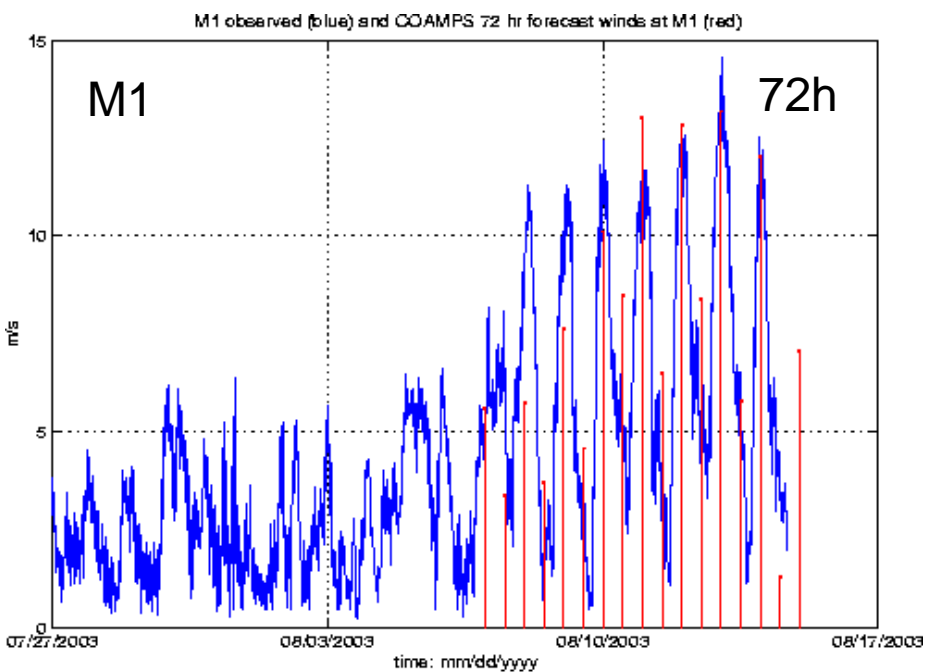

ESSE Surface Salinity Error Standard Deviation Forecasts

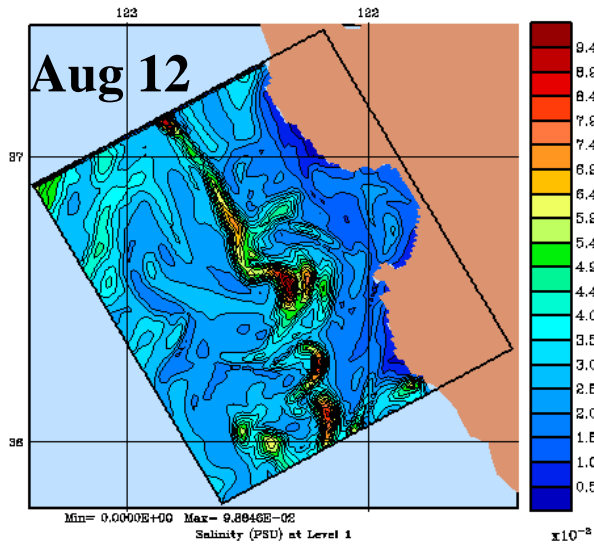

Start of Upwelling

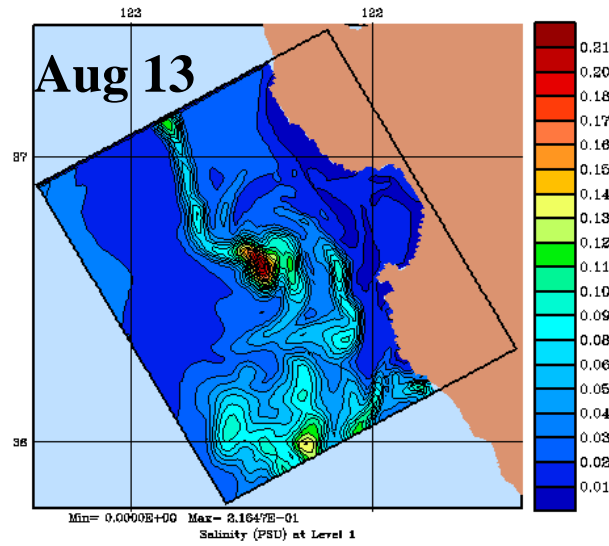

First Upwelling period

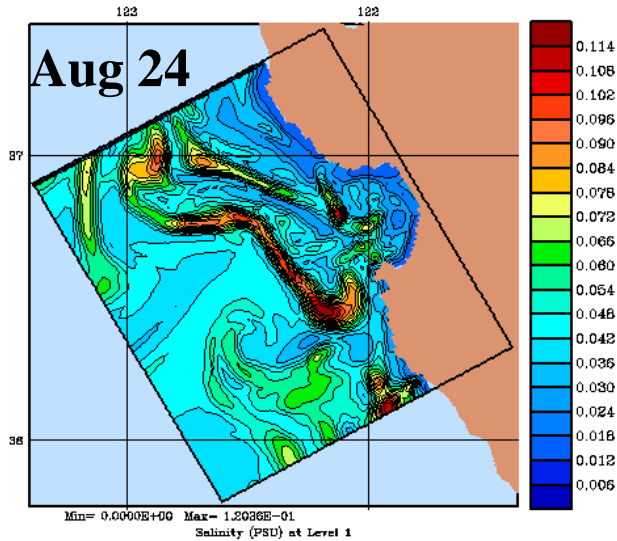
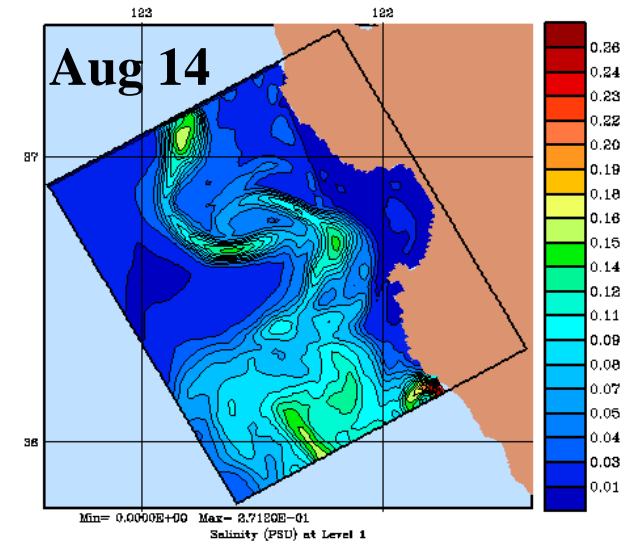

End of Relaxation

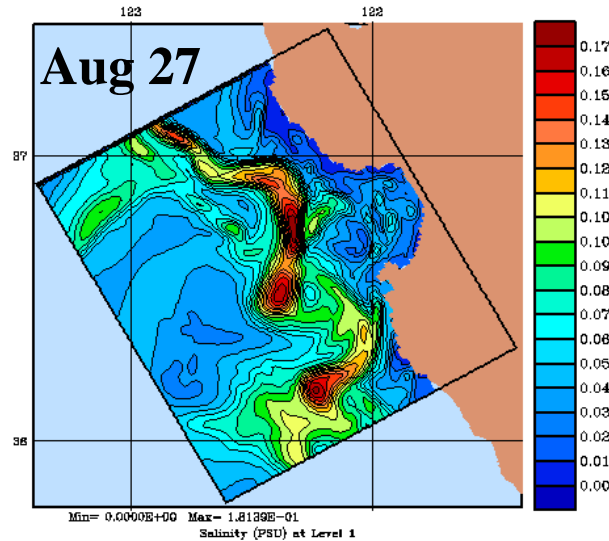

Second Upwelling period

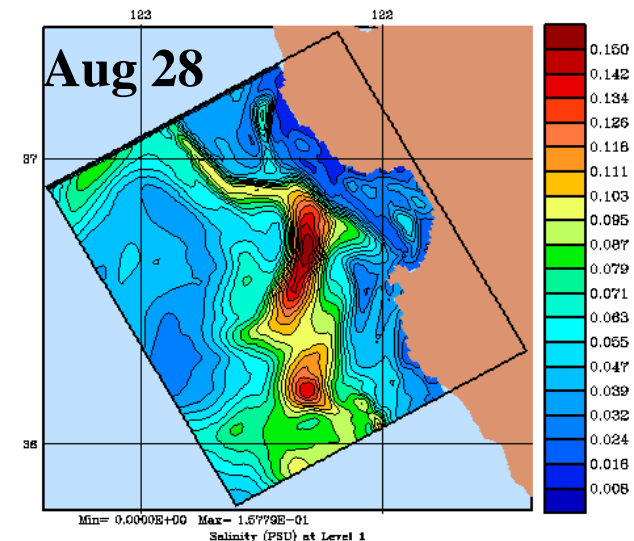

ESSE Surface Temperature Error Standard Deviations: Before and After ESSE data assimilation

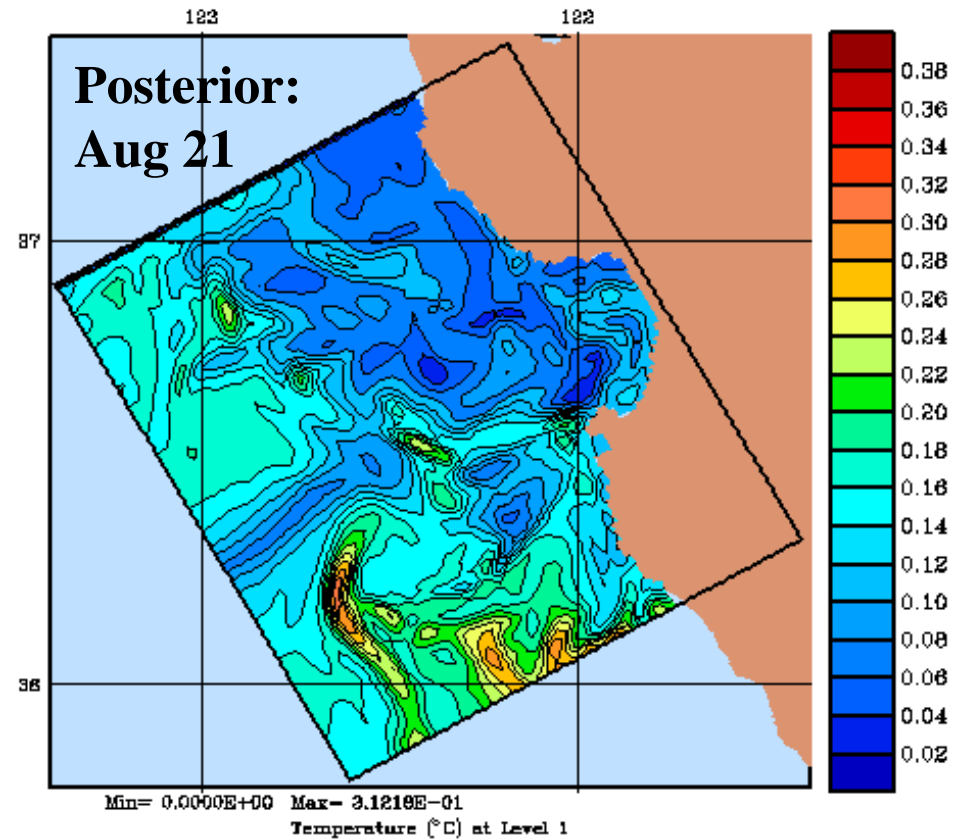
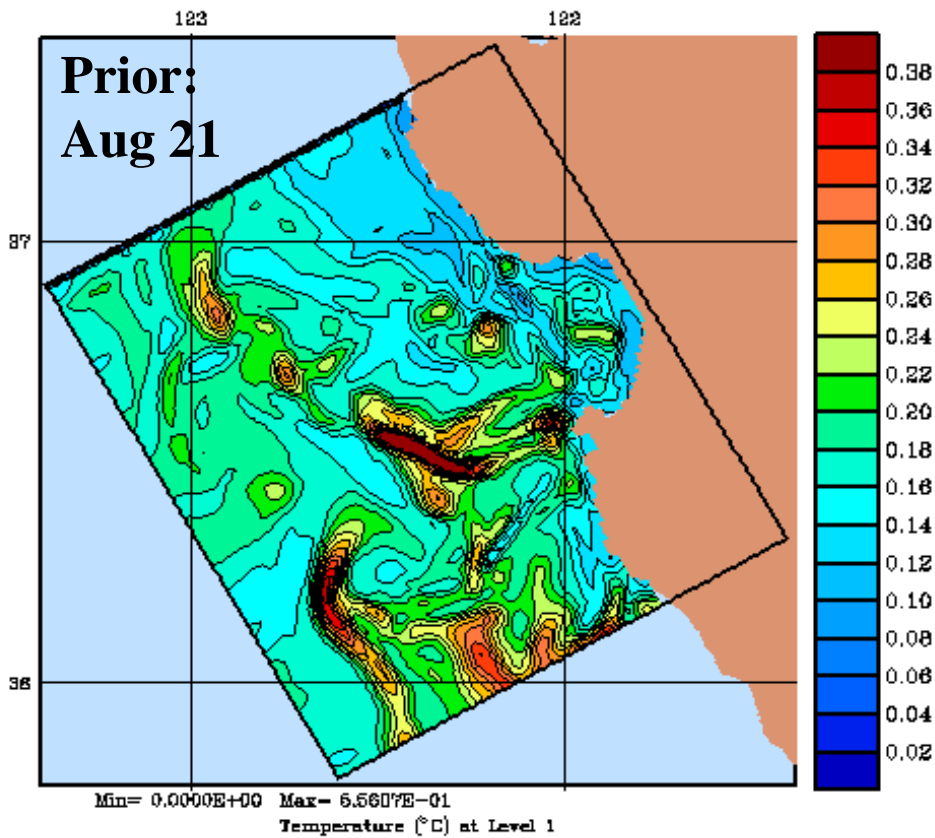

ESSE Field and Error Modes Forecast for August 28 (all at 10m)

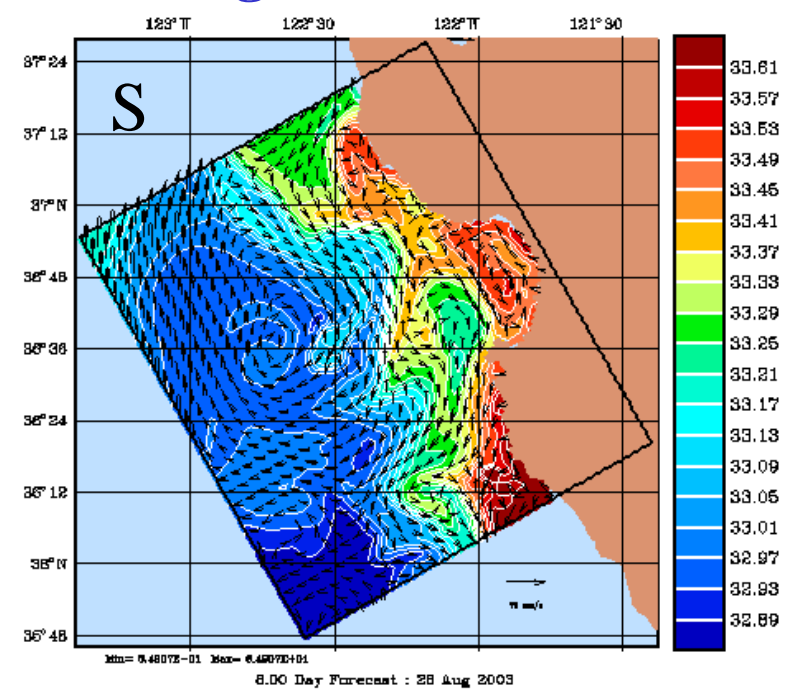
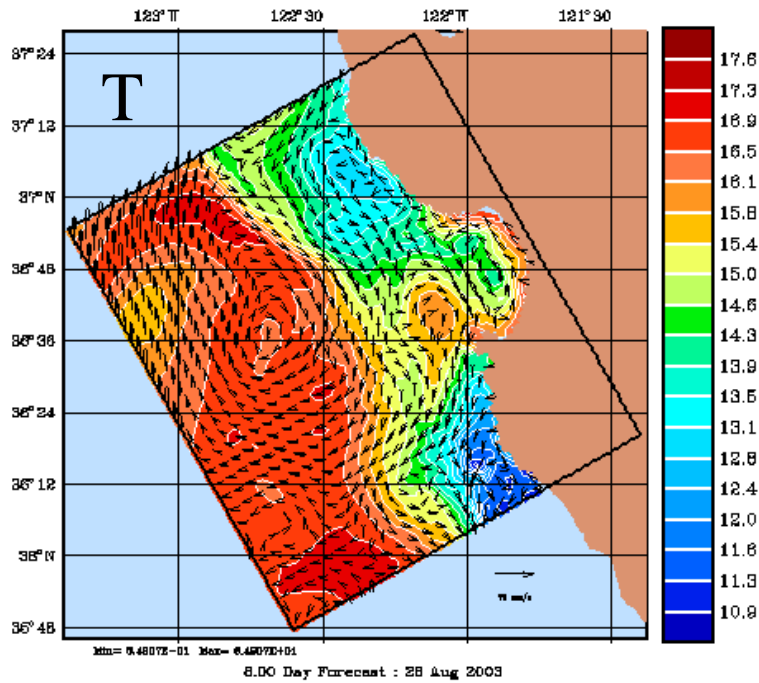

ESSE T error-Sv

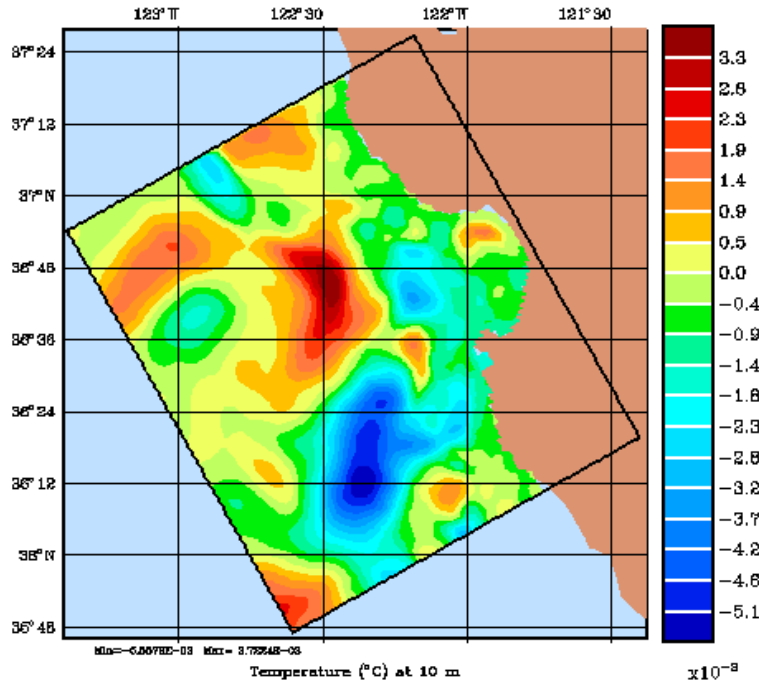

ESSE S error-Sv

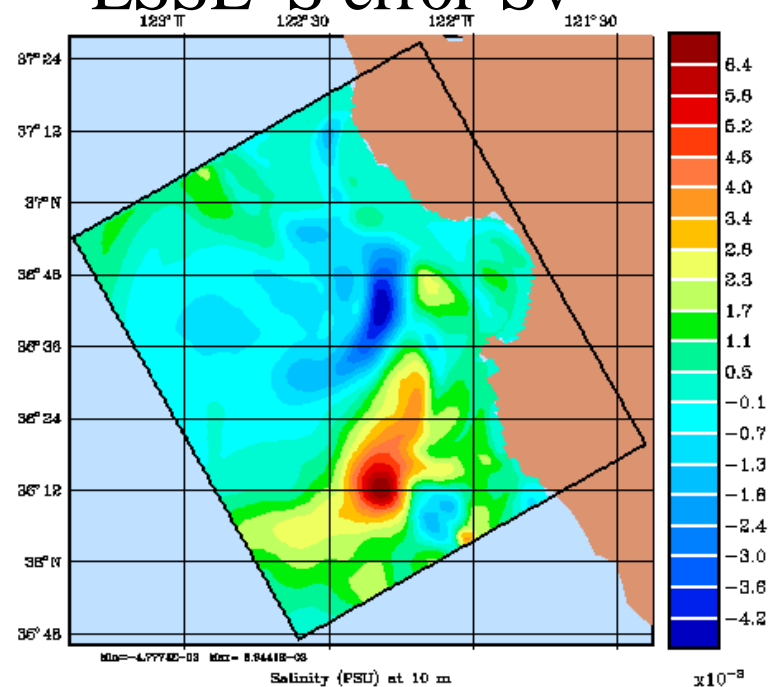

Non-Automated Real-time Adaptive Modeling during AOSN2

Adaptive modeling:

- Models structures and parameters adapt to new data
- Allows the optimal use of approximate models for rapidly evolving ocean dynamics

Prior to experiment, models calibrated to historical conditions judged to be similar to these expected in August 2003.

Ten days in the experiment:

- Parameterization of the transfer of atmos. fluxes to upper layers (wind mixing) adapted to new 2003 data
- Improved upper-layer T and S fields, but also currents.

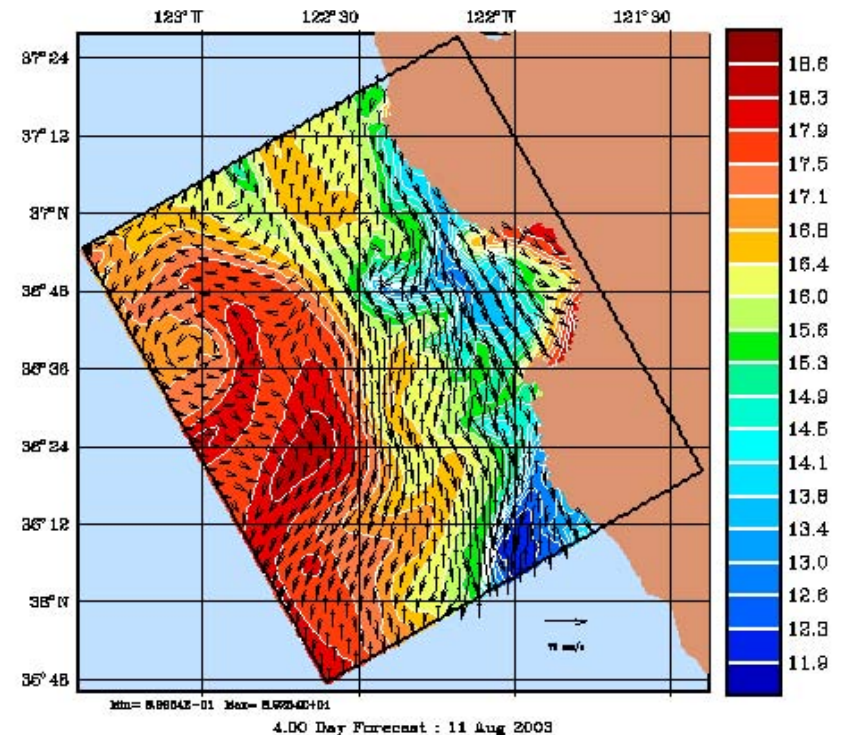
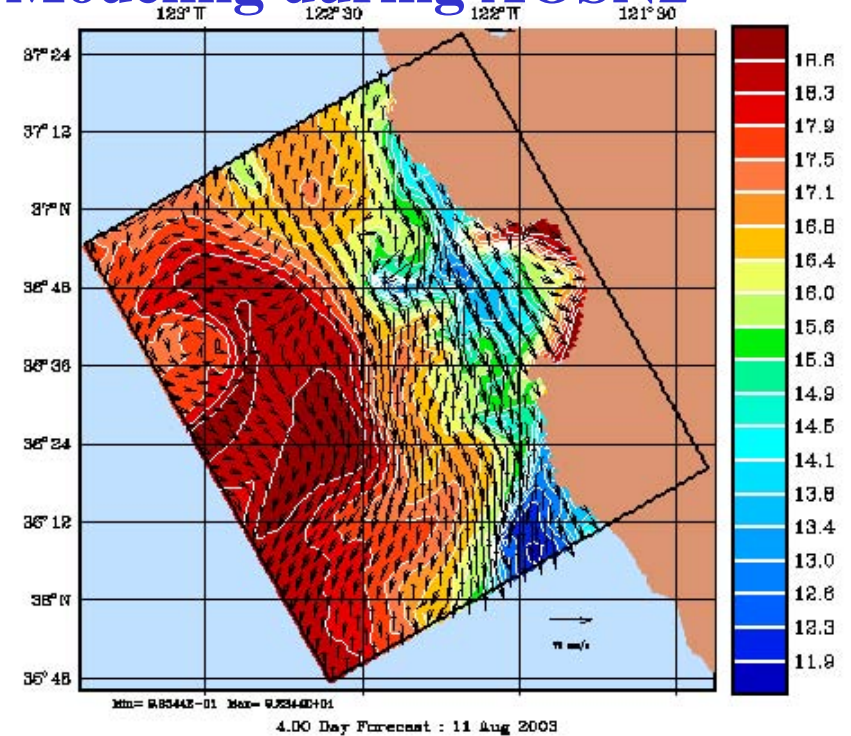
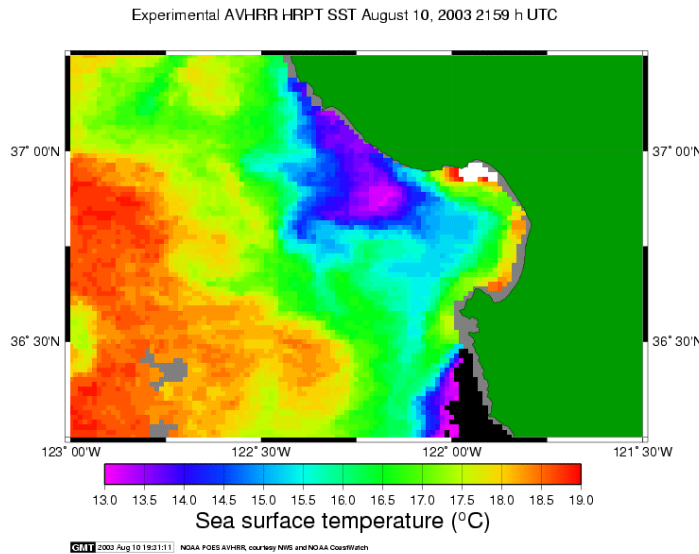

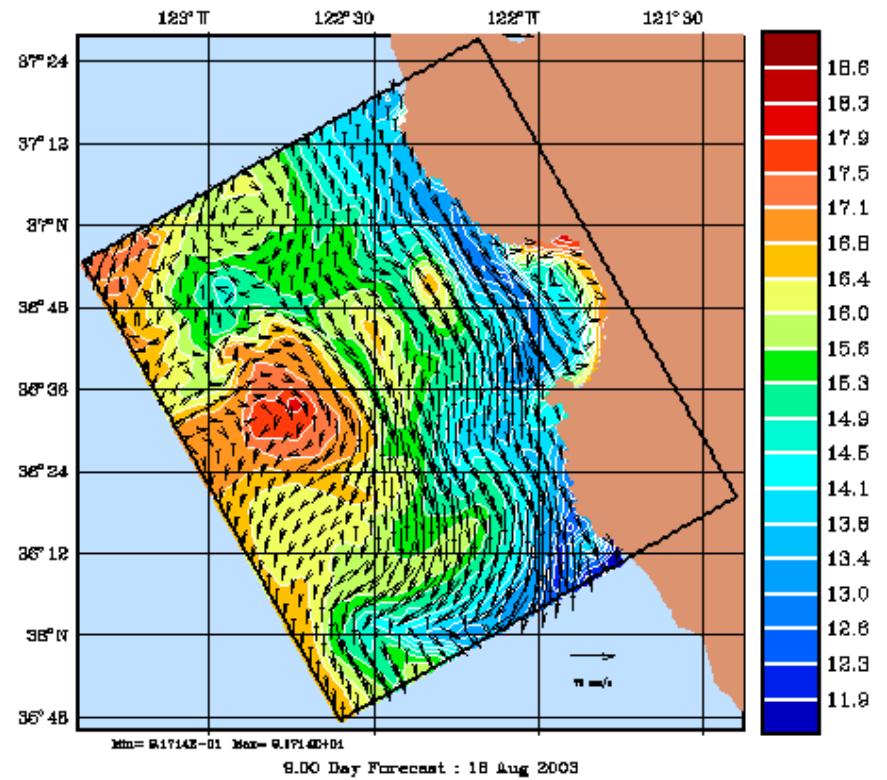
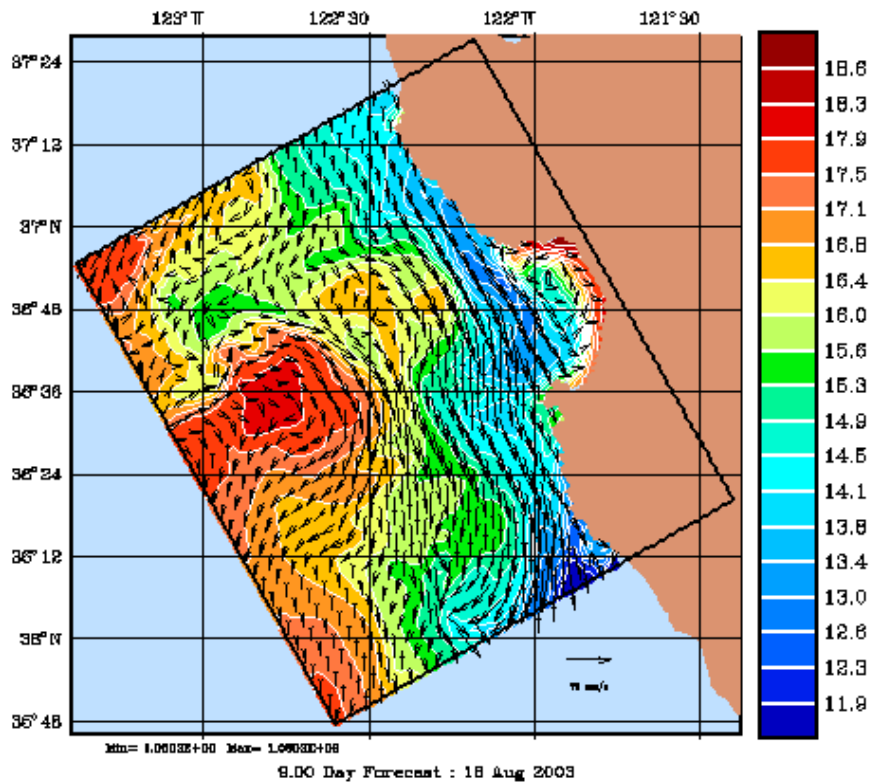

Experimental AVHRR HRPT SST August 15, 2003 1858 h UTC

