

DIGITAL COMPASS SOLUTIONS

Features

- 1° Heading Accuracy, 0.1° Resolution
- 0.5° Repeatability
- ±60° Tilt Range (Pitch and Roll) for HMR3300
- Small Size (1.0" x 1.45" x 0.4"), Light Weight
- Compensation for Hard Iron Distortions, Ferrous Objects, Stray Fields
- 15Hz Response Time
- -40° to 85°C Operating Temperature Range
- 6-15 volt DC unregulated or 5 volt regulated supply

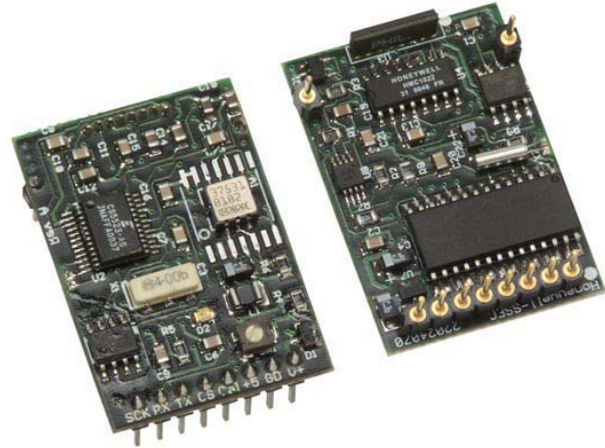

General Description

The Honeywell HMR3200/HMR3300 are electronic compassing solutions for use in navigation and guidance systems. Honeywell's magnetoresistive sensors are utilized to provide the reliability and accuracy of these small, solid state compass designs. These compass solutions are easily integrated into systems using a UART or SPI interface in ASCII format.

The HMR3200 is a two-axis compass, and can be used in either vertical or horizontal orientations.

The HMR3300 is a three-axis, tilt compensated compass that uses a two-axis accelerometer for enhanced performance up to a ±60° tilt range.

APPLICATIONS

- Compassing & Navigation
- Attitude Reference
- Satellite Antenna Positioning
- Platform leveling
- GPS Integration
- Laser Range Finders

Block Diagram

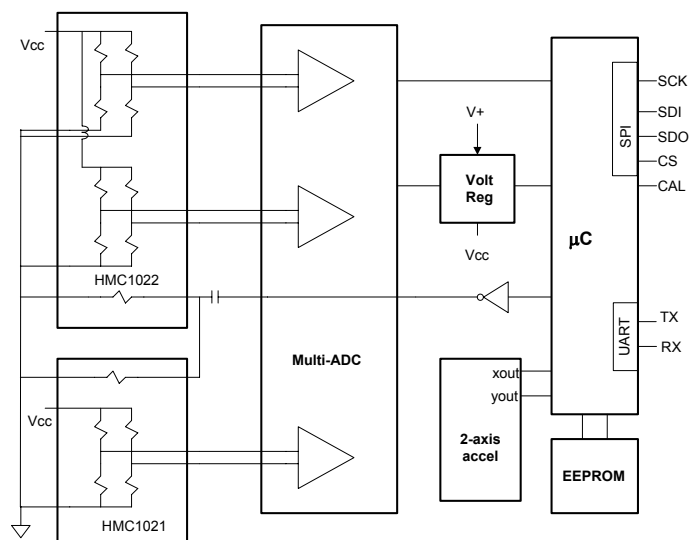

SPECIFICATIONS

Characteristics	Conditions	Min	Typ	Max	Units
-----------------	------------	-----	-----	-----	-------

Heading

Accuracy	Level		1.0		deg RMS
	0° to ±30° (HMR3300 only)		3.0		
	±30° to ±60° (HMR3300 only)		4.0		
Resolution			0.1		deg
Hysteresis	HMR3200		0.1	0.2	deg
	HMR3300		0.2	0.4	
Repeatability	HMR3200		0.1	0.2	deg
	HMR3300		0.2	0.4	

Pitch and Roll (HMR3300 only)

Range	Roll and Pitch Range		± 60		deg
Accuracy	0° to ± 30°		0.4	0.5	deg
	± 30° to ± 60°		1.0	1.2	
Null Accuracy*	Level		0.4		deg
	-20° to +70°C Thermal Hysteresis		1.0		
	-40° to +85°C Thermal Hysteresis		5.0		
Resolution			0.1		deg
Hysteresis			0.2		deg
Repeatability			0.2		deg

Magnetic Field

Range	Maximum Magnetic Flux Density		± 2		gauss
Resolution			0.1	0.5	milli-gauss

Electrical

Input Voltage	Unregulated	6	-	15	volts DC
Current	HMR3200		18	20	mA
	HMR3300		22	24	

Digital Interface

UART	ASCII (1 Start, 8 Data, 1 Stop, 0 Parity) User Selectable Baud Rate	2400	-	19200	Baud
SPI	CKE = 0, CKP = 0 Psuedo Master				
Update	Continuous/Strobed/Averaged				Hz
	HMR3200		15		
	HMR3300		8		
Connector	In-Line 8-Pin Block (0.1" spacing)				

* Null zeroing prior to use of the HMR3300 and upon exposure to temperature excursions beyond the Operating Temperature limits is required to achieve highest performance.

Characteristics	Conditions	Min	Typ	Max	Units
Physical					
Dimensions	Circuit Board Assembly		25.4 x 36.8 x 11		mm
Weight	HMR3200 HMR3300		7.25 7.5		grams

Environment

Temperature	Operating (HMR3200)	-40	-	+85	°C
	Operating (HMR3300)	-20	-	+70	°C
	Storage	-55		+125	°C

Pin Configuration

Pin Number	Pin Name	Description
1	SCK	Serial Clock Output for SPI Mode
2	RX/SDI	UART Receive Data/SPI Data Input
3	TX/SDO	UART Transmit Data/SPI Data Output
4	CS	Chip Select for SPI Mode (active trailing edge)
5	CAL	Calibration ON/OFF Input (active trailing edge)
6	+5VDC*	+5 VDC Regulated Power Input
7	GND	Power and Signal Ground
8	+V*	Unregulated Power Input (+6 to +15 VDC)

*Note: Use either pin 6 (+5VDC) or pin 8 (+V) to power the circuit board. Hold the board with pin header edge close to you and pins pointing DOWN. Then PIN 1 is the left most pin.

CIRCUIT DESCRIPTION

The HMR3200/HMR3300 Digital Compass Solutions include all the basic sensors and electronics to provide a digital indication of heading. The HMR3200 has all three axis of magnetic sensors on board, but allows the user to select which pair of sensors for compassing (flat or upright). The HMR3300 uses all three magnetic sensors plus includes an accelerometer to provide tilt (pitch and roll) sensing relative to the board's horizontal (flat) position.

The HMR3200/HMR3300 circuit starts with Honeywell HMC1021 and HMC1022 single and two-axis magnetic sensors providing X, Y, and Z axis magnetic sensing of the earth's field. These sensors are supplied power by a constant current source to maintain best accuracy over temperature. The sensor output voltages and constant current sensor supply voltage are provided to multiplexed Analog to Digital Converter (ADC) integrated circuit. A microcontroller integrated circuit periodically queries the multiplexed ADC and performs the offset corrections and computes the heading. This microcontroller also performs the external serial data interface and other housekeeping functions such as the calibration routine. An onboard EEPROM integrated circuit is employed to retain necessary data variables for best performance.

For the HMR3300, an additional pair of data inputs from the $\pm 2g$ accelerometer is received by the microcontroller. These tilt inputs (pitch and roll) are added to sensor data inputs to form a complete data set for a three dimensional computation of heading.

The power supply for the HMR3200/HMR3300 circuit is regulated +5 volt design allowing the user to directly provide the regulated supply voltage or a +6 to +15 volt unregulated supply voltage. If the unregulated supply voltage is

provided, then the linear voltage regulator integrated circuit drops the excess supply voltage to a stable +5 volts. The power supply is a dual ground (analog and digital) system to control internal noise and maximize measurement accuracy.

PHYSICAL CHARACTERISTICS

The circuit board for the HMR3200/HMR3300 Digital Compassing Solutions is approximately 1.45 by 1 inches. An 8-Pin header protrudes down on one edge of the board for the user interface or the demo board. The header pins extend 5/16" below the board plane with the bottom-side mounted magnetic sensor integrated circuits (HMC1021 and HMC1022) extending 3/16" below the board plane. Components on the top-side have a maximum height of 1/8". Figure 1 shows a typical circuit board with dimensions.

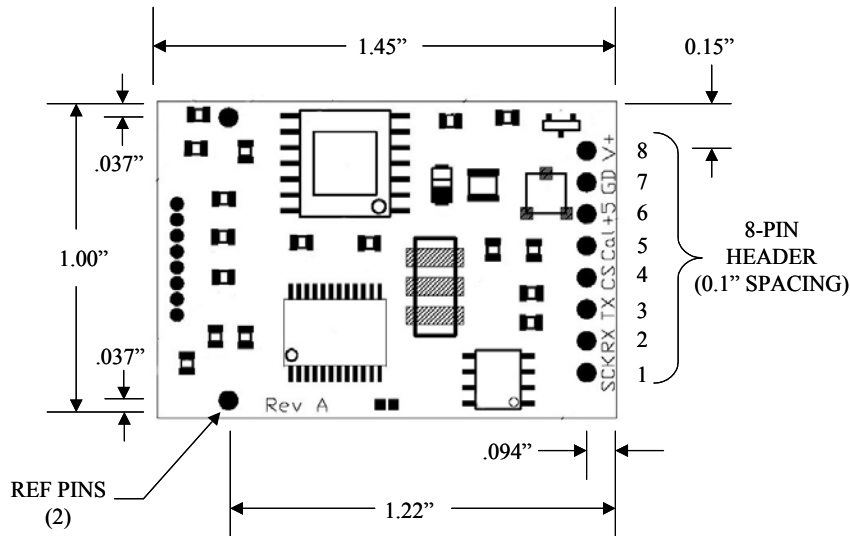

Figure 1

Application Notes

UART COMMUNICATION PROTOCOL

HMR3200/HMR3300 modules communicate through ASCII characters. The data bit format is 1 Start, 8 Data, 1 Stop, and No parity bits. Asynchronous communication has the complete menu of commands.

OPERATIONAL COMMANDS

Syntax: *X<cr><lf> Sends command for an operational mode change

Heading Output Command

*H<cr><lf>

Selects the Heading output mode (factory set default). This configuration is saved in non-volatile memory.

Format: Heading

Eg: 235.6

Magnetometer Output Command

*M<cr><lf>

Selects the magnetometer output mode. This configuration is saved in non-volatile memory.

Format: MagX, MagY, MagZ

Eg: 1256, -234, 1894

Compass Orientation (HMR3200 only)

***L<cr><lf>**

Heading calculation is done assuming the compass is level.

***U<cr><lf>**

Heading calculation is done assuming the compass is upright (connector end down).

These orientation commands are saved in non-volatile memory.

Starting and Stopping Data Output

***S<cr><lf>**

The data output will toggle between Start and Stop each time this command is issued (factory set default is Start, first Start/Stop command will stop data output).

Query

***Q<cr><lf>**

Query for an output in the currently selected mode (Mag/Head). Allowed only in Stop data mode.

Roll Axis Re-Zero

***O<cr><lf>**

Allows the user to zero the roll output. This command should only be issued when the roll axis is leveled ($\pm 0.3^\circ$).

Pitch Axis Re-Zero

***P<cr><lf>**

Allows the user to zero the pitch output. This command should only be used when the pitch axis is leveled ($\pm 0.3^\circ$).

Averaged Output

***A<cr><lf>**

Same result as the query command except that the data is the result of an averaging of the last 20 readings. Allowed only in Stop data mode.

Split Filter Toggle

***F<cr><lf>**

Toggles the split filter bit. The parameter setting is saved in the EEPROM immediately. Requires power cycling or a reset command to activate.

Reset

***R<cr><lf>**

Resets compass to power-up condition.

User Calibration

***C<cr><lf>**

Command to be issued to enter and exit the calibration mode.

Once in the calibration mode, the device will send magnetometer data appended by a "C" character to indicate the Calibration Mode operation.

Eg. 123,834,1489,C

During the calibration procedure, the compass and the platform to which the compass is attached is rotated at a reasonably steady speed through 360 degrees. This process should at least take one minute for best accuracy. In case of HMR3200, the rotation should be in the horizontal flat plane. For HMR3300, the rotation should include as much pitch and roll orientations possible. At the completion of the rotations, issue another ***C<cr><lf>** to exit the calibration mode.

CONFIGURATION COMMANDS

Syntax: #Dev= \pm xxxx<cr><lf> Sets parameter value
 #Dev?<cr><lf> Queries for the parameter value

Variation Input (Declination Angle Correction)

#Var= \pm nnnn<cr><lf> where the variation is \pm nnn.n degrees
 Sets the angle between magnetic north and geographic north.
 Eg: #Var=-203<cr><lf> sets the declination angle to -20.3 degrees.
 Eg: #Var=?<cr><lf> returns the declination angle; -20.3

Deviation Input (Platform Angle Correction)

#Dev= \pm nnnn<cr><lf> where the angle is \pm nnn.n degrees
 Sets or returns the angle between compass forward direction and that of the mounting platform.
 Eg: #Dev=23<cr><lf> sets the deviation angle to +2.3 degrees.
 Eg: #Dev=?<cr><lf> returns the deviation angle; +2.3

User Magnetic offset values (X, Y and Z)

#Xof, #Yof, #Zof
 Sets or returns the user offset values for each magnetic axis.
 Eg: #Xof=+47<cr><lf> sets the x offset value to +47.
 Eg: #Xof=?<cr><lf> returns the x offset value; +47.

Baud Rate

#Bau
 Sets the compass baud rate. 19200, 9600, 4800 and 2400 are the only allowed values. Baud rate can not be queried.

System Filter

#SFL
 Sets and reads the system IIR filter setting. When the Split Filter bit is cleared, this parameter value will become the default value for Magnetic and Tilt Filters. When the Split Filter bit is set, SFL parameter setting will control the Tilt filter value only. The parameter input is saved in the EEPROM immediately. Requires power cycling or a Reset command (*R) to become effective. The setting of the Split Filter bit can be queried via the #CON? command.
 Eg: #SFL=3<cr><lf> Sets the system filter value of 3.

Magnetic Filter

#MFL
 The MFL command sets and reads the Magnetic Filter setting. When the Split Filter bit is cleared, this parameter value will default to the value of SFL, the system filter. When the Split Filter bit is set, MFL parameter setting will control the Magnetic Filter value. The parameter input is saved in the EEPROM immediately. Requires power cycling or a Reset command (*R) to become effective.

Configuration

#CON?
 This command queries for the configuration status of the compass module. The output of the configuration value is in decimal representation (in ASCII format) of which the 16-bit binary pattern is defined below.

bit 15	bit 14	bit 13	bit 12	bit 11	bit 10	bit 9	bit 8
N/A	N/A	N/A	N/A	N/A	SplitFilter	Alarm	Warn
bit 7	bit 6	bit 5	bit 4	bit 3	bit 2	bit 1	bit 0
N/A	N/A	1	N/A	H Out	N/A	Mag Out	N/A

Parameter Name	Bit Value Reported	Effect
Mag Out	1	Magnetic Sensor Output Sentence selected
H Out	1	Heading Output Sentence selected
Warn	1	Device temperature has fallen below -10 C during this session of operation.
Alarm	1	Device temperature has fallen below -20 C during this session of operation.
SplitFilter	1	Independent Filter values for Magnetic and Tilt are used

Eg: #CON? Returns a response of #D=1028<cr><lf> meaning independent filters used for magnetic and tilt data (bit 10 set) and the compass module is sending heading data (bit 3 set).

COMMAND RESPONSES

These are compass module generated responses to commands issued by the host processor. These responses follow in format to the commands issued.

#Dxxx<cr><lf>
Returns data requested.

#I<cr><lf>
Invalid command response. Response to any invalid command.

SPI INTERFACE

SPI operating Mode is as follows:

SCK idles low
Data Output after falling edge of SCK
Data sampled before rising edge of SCK

(MODE CKP=0, CKE=0)

Synchronous Communication Protocol

The HMR3200/HMR3300 module controls the synchronous clock (SCK) and synchronous data output (SDO) pins and the host controller controls synchronous data input (SDI) and chip select (CS) pins. The host controller shall lower the HMR module's CS pin for at least 20 microseconds to initiate the SPI communication. In response the HMR module will send the ASCII bit pattern for 's', and the host shall transmit a valid command character simultaneously. The HMR module will evaluate the command character received from the host controller and send the appropriate data if the command is recognized and valid. After transmitting the required data, the HMR module will end the SPI session. If the command is invalid or was not recognized, then the HMR module will transmit ASCII bit pattern for 'e' and end the SPI session.

SPI Commands

Heading Output: In response to an ASCII H or h command, the HMR3200/HMR3300 shall send two bytes of data. The MSByte is transmitted first. These two bytes represent the integer value equal to 10*Heading. The MSbit is transmitted first for each byte. SCK shall be high for 16, and low for 22 microseconds, respectively. There is a 50 microsecond delay between consecutive bytes transmitted.

Command Character	Action	SPI Data Output	Parameter Value
H or h	Sends heading data	0000 to 3599	Heading: 000.0 to 359.9

DATA REPRESENTATION

Heading Output: In response to an H or h command, HMR3200/HMR3300 module shall send two bytes of data. The MSByte is transmitted first. These two bytes represent the integer value equal to 10*Heading. The MSbit is transmitted first for each byte.

SPI TIMING

The SCK shall be high for 16, and low for 22 microseconds, respectively. There is a 50 microsecond delay between consecutive bytes transmitted.

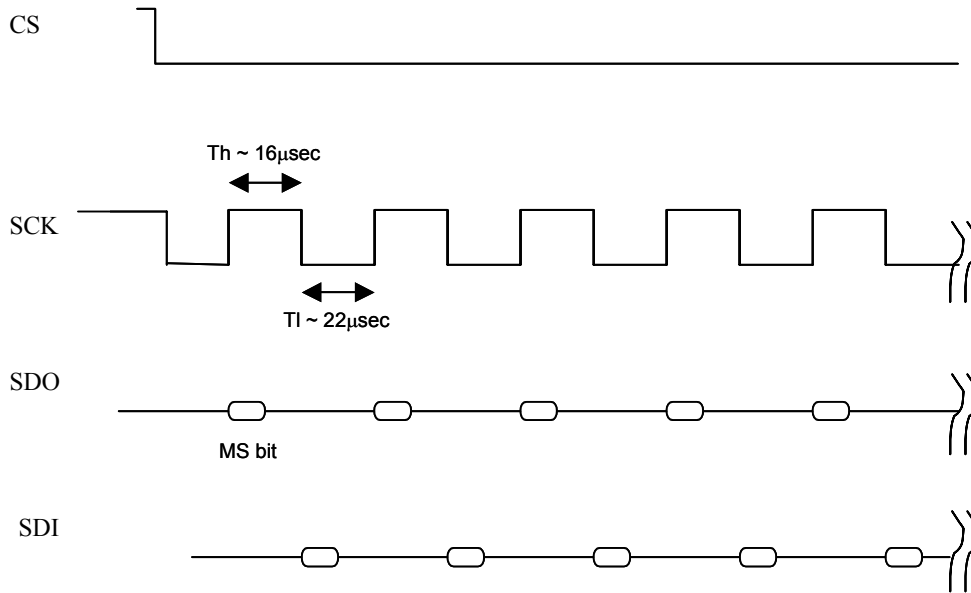

SPI Timing Diagram

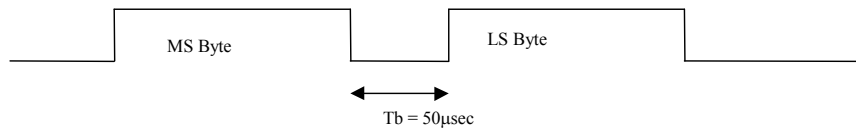

SPI Heading Output

Demonstration PCB Module Kit

The HMR3200 (HMR3300) Demo Module includes additional hardware and Windows software to form a development kit for electronic compassing. This kit includes the HMR3200 (HMR3300) Printed Circuit Board (PCB) module, an RS-232 motherboard with D9 serial port connector, serial port cable with attached AC adapter power supply, interface software, and documentation.

Ordering Information

Ordering Number	Product
HMR3200	PCB Module Only
HMR3200-Demo-232	PCB Module with Development Kit
HMR3300	PCB Module Only
HMR3300-D00-232	PCB Module and RS-232 Motherboard
HMR3300-Demo-232	PCB Module with Development Kit

Honeywell reserves the right to make changes to improve reliability, function or design. Honeywell does not assume any liability arising out of the application or use of any product or circuit described herein; neither does it convey any license under its patent rights nor the rights of others.

900266 01-03 Rev. D