

GIVENness, AvoidF and other Constraints on the Placement of Accent

Roger Schwarzschild
Rutgers University
sroger@rucss.rutgers.edu

ABSTRACT

This paper strives to characterize the relation between accent placement and discourse in terms of independent constraints operating at the interface between syntax and interpretation. The **GIVENness Constraint** requires un-F-marked constituents to be GIVEN. Key here is our definition of GIVENness which synthesizes insights from the literature on the semantics of focus with older views on information structure. **AvoidF** requires speakers to economize on F-marking. A third constraint requires a subset of F-markers to dominate accents.

The characteristic prominence patterns of "novelty focus" and "contrastive focus" both arise from a combination of the GIVENness Constraint and AvoidF. Patterns of prominence in questions as well as in answers to questions are explained in terms of the constraints, thanks in part to the way in which the GIVENness relation is defined. Head/argument asymmetries noted in the literature on Focus Projection are placed in the phonology-syntax interface, independent of discourse conditions. Deaccenting follows when AvoidF is ranked higher than constraint(s) governing head/argument asymmetries.

While the distinction between 'given' and 'new' plays an important role in explaining patterns of intonational prominence, there has always been a difficulty surrounding these terms. In Halliday(1967), for example, 'given' is clearly and consistently defined as "anaphorically recoverable". 'new', on the other hand, is defined as "textually and situationally non-derivable information" but also as "contrary to some predicted or stated alternative" (206) and as "replacing the WH-element in a presupposed question" (226). Taking prominence to correlate with 'new', the first definition helps explain why the object in (1A) from Ladd(1980:55) is prominent but the object in (1B) is not. The second definition of 'new' is needed for (2) while (3) necessitates the third definition.

- (1) A. Why don't you have some French TOAST?
B. I've forgotten how to MAKE French toast.
- (2) {John's mother voted for Bill.}
no, she voted for JOHN.
- (3) {Who did John's mother vote for?}
She voted for JOHN.

This mix of apparently unrelated definitions has led many to simply give up the pretense of a unified notion of novelty, adopting instead a variety of semantic/pragmatic notions to correlate with prominence. Without denying that factors other than givenness come into play, I wish to argue in favor of Halliday's original impulse to lump together (2-3) with more convincing examples of the effect of information status on intonation. Halliday's difficulties arise from a redundancy in his system. 'Given' and 'new' are originally introduced as concepts that are complementary both in their definition as well as in their reflex in the phonology. The correct theory should therefore only make reference to one of them. Since, as noted above, 'given' receives a straightforward interpretation, I suggest that its

complement, 'new', be eliminated from the theory. The correlation with phonology argues in this direction as well. Except for certain syntactically defined cases to be discussed below, the generalization in (4a) below is robust, (4b) is not (Taglicht 1982:222,(ii)).

- (4) a. Lack of prominence indicates givenness.
- b. Prominence indicates novelty.

This asymmetry is supported by the fact that deictics and other words appear to be inherently given (Halliday(1967:206)), but one doesn't find words that are inherently novel. I submit therefore that the grammar makes reference to givenness and includes a statement like (4a) but that no mention is made of novelty, hence there is nothing like (4b).

This cannot be the whole story, however. Even if it is too broadly stated, (4b) does have some truth to it and this will be explained in terms of a constraint, Avoid F. This constraint has the effect of requiring a speaker to refrain from accenting material that is given. In many but crucially not all cases, the presence of such a constraint allows a hearer to conclude that if material is in fact made prominent, it must not be given. In those cases, (4b) obtains. But this circumstance is not the rule, as (2-3) showed. (3) itself is not given, hence some part of it must be intonationally prominent. On the other hand, there is no need for the entire utterance to be so marked. (3), we will show, is the best one can do to satisfy Avoid F without running up against (4a). Under this view, lack of prominence correlates directly with givenness, while prominence correlates indirectly with novelty, and the range of examples in (1-3) fall together.

Prominence located on a syllable affects the discourse appropriateness of a word or phrase containing that syllable. This fact raises a number of questions:

- (5) a. What are the primitives of the theory of discourse appropriateness?
- b. What are the units, syntactic or otherwise, to which appropriateness conditions apply?
- c. What is the relation between a unit of discourse appropriateness and the locus of prominence?
- d. What are the ingredients of intonational prominence?

Much of the literature on this topic is arranged around a syntactic notion of "focus". Research into the semantics of focus often presupposes that constituents have already been phonologically identified as foci, while phonologists and phoneticians study the properties of foci identified in terms of specialized discourse contexts such as answers to Wh-questions or contrastive statements. These two lines come together in Selkirk's contribution to the Handbook of Phonology(1996) which serves as the starting point for our discussion. Selkirk answers the questions in (5) by defining a set of possible syntactic structures annotated with F-markers. Constituents of these F-marked structures are subject to rules of discourse and F-marked words are possible bearers of pitch accents.

In section 1, Selkirk's system is critically reviewed. The role of givenness in that theory is of particular interest. Section 2 precisely defines what it means to be given. The definition is crafted to make sense of the appeal to givenness in Selkirk's theory. It will draw on earlier work on givenness as well as contrastive focus. This new understanding of what givenness is

leads in section 3 to a unified account of contrastive focus, presentational focus, focus in questions and focus in answers to questions. In section 6, we turn to issues of syntax. F-markers in Selkirk's theory are more than just convenient labels on which to state rules of semantics and of phonology. There are non-trivial syntactic rules which govern F-markers and which have consequences for how appropriateness relates to prominence. In section 6.1, we argue against these syntactic rules. In section 6.3, the phenomena they cover are subsumed by a set of ranked constraints relating freely F-marked syntactic structures to accent placement. We stop short of eliminating F-marking altogether, but this move is strongly suggested.

1. SELKIRK(1996)

Intonational prominence is marked, at least in part, by the presence of a pitch accent, in English as well as other languages. The pitch accenting of words can be used to indicate their information status as well as the information status of phrases containing them. The latter case is understood to involve the projection of **F-marking** from an accented word to a phrase and pragmatic rules then make reference to F-marking. F-Projection is sensitive to argument structure and to the head-phrase relation (Schmerling(1976), Gussenhoven(1983), Selkirk(1984), Rochemont(1986), see Rochemont (1997) for recent discussion). Selkirk(1996) provides the rules in (6):

(6)

F-Assignment Rules

Basic F Rule

An accented word is F-marked.

F Projection

- (a) F-marking of the *head* of a phrase licenses the F-marking of the phrase.
- (b) F-marking of an *internal argument* of a head licenses the F-marking of the head.¹

To see how F-assignment works, consider the following F-marked example, where capitalization indicates that a word is pitch-accented:

- (7) {What did Mary do?}
 A: She [[praised]_F [her [BROTHER]_F]_F]

In (7), accent on *brother* entails that it is F-marked, by the Basic F Rule. This licenses the F-marking of the NP *her brother*, by (6a). Since *her brother* is the internal argument of the verb, the verb can be F-marked by (6b), which in turn licenses the F-marking of the VP by (6a). The rules in (6) explain how accenting *brother* in (7A) allows it to conform to the generalization in (8) below, echoing the earlier quote from Halliday(1976):

- (8) An appropriate answer to a Wh-question must have F marking on the constituent corresponding to the Wh-phrase.

A crucial aspect of Selkirk's algorithm is the possibility of embedding F-marking. Its

significance can be appreciated by comparing (7) with (9):

- (9) {What did John's mother do?}
A: She [[PRAISED]_F him]_F.

In this case, accent on *praised* entails that it is F-marked, which in turn licenses the F-marking of the VP by (6a). Here too, the piece of the answer corresponding to the Wh-word *what* is F-marked. But this is achieved without F-marking the direct object as in the earlier example. Selkirk's account of the difference relies on the following generalizations:

- (10) a. Embedded F-markers indicate novelty in the discourse.²
b. The absence of F-marking indicates givenness in the discourse.

In (9A), where the object NP represents given information, it may not be F-marked, while in (7A), where the object NP and its head represent novel information they must be F-marked, hence *brother* is accented.

Summarizing, accenting indicates F-marking, F-marking projects upward and in this fashion F-marking on a phrase comes to be indicated with the accenting of a subpart of that phrase. This account presupposes embedded F-markers. Embedded F-markers play a role in explaining how novelty and givenness affect accent placement.

The rules of F-assignment proposed in (6) in conjunction with the generalizations in (10) illustrate difficulties surrounding the appeal to givenness in an account of accent placement. To begin with, the connection between the embeddedness of F-markers and a novelty interpretation is mysterious. Empirical evidence for the embedded/non-embedded distinction comes from examples such as the following:

- (11) {Who did John's mother praise?}
A: she praised [HIM]_F

As in the earlier examples, the piece of the answer that corresponds to the Wh-word is F-marked. But in this case that entails F-marking of the object NP, *him*, which is no less given than the object in (9). The difference between the two is that the F-marker in this case is unembedded and hence it permits a given interpretation of the expression to which it is attached. But why should embeddedness matter in the first place?

Another challenge for a givenness account is the generalization in (8) concerning the F-marking of answers to Wh-questions. What is its source? On the one hand, it certainly seems that givenness should play a role. As has often been pointed out, it cannot be a coincidence that the string *she praised* is unaccented in an answer to a question containing the string *John's mother praise* (where *John's mother* and *she* are coreferent). On the other hand, the F-marker on *HIM* precludes any simple correlation between F-marking and novelty. By merely stipulating (8) we not only leave the connection to givenness unexplained, we also run into empirical problems, as in the following:

- (12) {John drove Mary's red convertible. What did he drive before that?}
A: he drove her [BLUE]_F convertible.

According to the rules of F-assignment, F-marking cannot project from a prenominal adjective like *blue* in (12) to higher nodes. This is generally the desired result. But in this case, it means that the piece of the answer corresponding to the Wh-word, the NP *her [BLUE]_F convertible*, is not F-marked. Note, by the way, that here too, a givenness account seems like it is on the right track. The strings *he drove her* and *convertible* are not F-marked and they both have antecedents in prior discourse and thus represent given information. If the generalization in (8) was in fact derived from other principles in the grammar, besides getting a more satisfying account, one might explain what is going on in (12).

The final and most important question has to do with the generalization in (10b) repeated below:

(10) b. The absence of F-marking indicates givenness in the discourse.

Consider the following variation on (12):

(13) {Mary's old convertible is no longer available. What is John going to do?}
He'll [[RENT]_F her [NEW]_F convertible]_F.

The NP *her NEW convertible* is not F-marked, and so a simple reading of b. says that it must represent given information. But does it? In the literature on givenness a referential NP is taken to represent given information if its referent has been previously mentioned and is salient (for exceptions not relevant at this point, see Prince(1981)). By that criterion, *her [NEW]_F convertible* is not given at the point at which it is 'uttered'. On the other hand, this phrase is not completely new either. Intuitively, the phrase as a whole is not F-marked because it is only **partly** new.

What the last few problems show is that we need a notion of givenness that is flexible enough to apply to non-constituents (Taglicht1982,84) such as *John's mother praise*, in the case of (11), *he drove her __ convertible* in (12) and *her__ convertible* in (13). We turn to these problems in the next section. The solution will turn out to have far reaching consequences for the rest of the theory.

2. GIVEN

2.1 Defining GIVEN

In an effort to spell out what is meant by "given", I will begin with an intuition prevalent in the literature on givenness. This will then be developed to the point where it can be used in stating the connection between givenness and F-marking in the difficult cases discussed in the last section. I save the more formal aspects of the proposal for section 2.2.

The core intuition around what it means for an utterance to express given information is that the utterance is already entailed by the discourse. Let us apply the term "given" to expressions themselves and begin with the following definition:

(14) An utterance is **given** iff it is entailed by prior discourse.

(14) is based on entailment, a relation holding between propositions. But we want to apply the term "given" to expressions of any type (Allerton 1978:151). To remedy this, assume a sort of type shifting operation that raises expressions to type t , by existentially binding unfilled arguments. If the phrase *green apple* has been mentioned, then we will take an utterance of *apple* to be given, since:

(15) $\exists x(\text{green-apple}(x)) \text{ ENTAILS } \exists x(\text{apple}(x))$

The operation that allows us to generalize the notion of entailment will be called "existential type shifting".

The example just discussed, in which *apple* is considered given because *green apple* has been mentioned, shows that we really want to define what it means to be given in terms of portions of prior discourse. So, we should revise (14) as follows:

(16) An utterance U counts as **given** iff it has an antecedent A and A entails U , modulo \exists -type-shifting.

The definition in (16) covers not only cases where an expression is literally repeated (*green apple...apple*) but it also predicts that the utterance of a noun counts as given based on the prior use of a hyponym, as in Rochemont(1986:50)'s example where *animal* counts as given based on a prior use of *gorilla*.

In going from (14) to (16), the definition of GIVENness has been modified so that an expression could be GIVEN even if it is not entailed by the entire prior discourse. This is illustrated in the following example:

(17) {If John ate a green apple, he will lose the contest.}
Don't WORRY, he ate a RED apple.

in the phrase *RED apple*, *apple* is unaccented because it is GIVEN. Prior discourse does not entail that John ate an apple nor that there any apples altogether. However, the phrase *green apple* may serve as an antecedent for the subsequent use of *apple*, hence by (16) it can count as GIVEN.

A word should be said about the term "antecedent". As in the anaphora literature, so in the literature on givenness and deaccenting, researchers have found various factors that affect the ability of one expression to count as an antecedent for another, including recency and frequency of mention (Allerton 1978:142-3) as well as grammatical role and position in the sentence (for recent discussion see Terken and Hirschberg(1994)). In this section, I will not have anything to say about these matters, but we should amend the definition slightly to take account of them:

(18) An utterance U counts as **given** iff it has a salient antecedent A and A entails U , modulo \exists -type shifting.

Recall that the purpose of defining what it means to be given is to allow for an explanation of when and where one finds F-marking. It is meant to be used in applying the

rule in (19) below:

(19) Non-F-marked constituents are given.

Unfortunately, the combination of (18) and (19) fails in even simple cases. Consider the utterance in (20B) below in response to A:

(20) {A: John ate a green apple.}
B: No, he ate a RED apple.

On the level of individual words, our definition works fine. In B, *ate* is not accented and hence could not be F-marked. By (19), that means it must be given, and indeed according to (18) it is given, since it also occurs in A, and:

$\exists x \exists y [\text{ate}(x)(y)] \text{ ENTAILS } \exists x \exists y [\text{ate}(x)(y)]$

But now we need to consider what happens above the word level. Following the rules of F-assignment, the accenting in B leads to the following F-marking:

(21) he ate a [RED]_F apple.

The F-marking on a prenominal adjective like *red* in (21) cannot project any higher. So (21) itself is not F-marked, hence it must be given, according to (19). But at the point at which it is uttered, no prior discourse entails its content, as required by (18). A similar point could be made here relative to the non-F-marked VP, *ate a [RED]_F apple*, as well as the non-F-marked object NP. If we are to maintain this connection between lack of F-marking and givenness, our definition of "given" needs revising.

According to (18), for something to be given it must have an antecedent, and intuitively (20A) is the antecedent for (20B). Indeed, it is the very fact that (20A) antecedes (20B) that explains the lack of F-marking in all of (20B) except for the word *red*. The problem with (18) lies then in the relation that it requires a given expression to bear to its antecedent. At the point at which (20B) is uttered, it is not entailed. However, in some sense what is entailed is "*he ate a Y apple*" where the F-marked part of (20B) has been replaced with a variable. The notion of entailment doesn't straightforwardly apply to expressions containing a free variable, so we will assume an existential quantifier binding these 'F-variables' (Williams 1980:8). In other words, we want to say that (20B) counts as given, because its antecedent, (20A), entails the result of replacing F-marked parts with existentially bound variables:

John ate a green apple ENTAILS $\exists Y$ [John ate a Y apple]

This last move leads to a revision of (18):

(22) An utterance U counts as **GIVEN** iff it has a salient antecedent A and modulo \exists -type shifting, A entails the result of replacing F-marked parts of U with existentially bound variables.

It should be pointed out that the existential quantifier binding F-marked phrases is not an

instance of existential type shifting, since for example [John ate a Y apple] is not the wrong **type** to be entailed. While existential type shifting is not involved in binding F-variables, there is one more place where we will want to use it. With respect to the VP in (20B), we would like to say that it counts as GIVEN because it has an antecedent in (20A), where:

$\exists x[x \text{ ate a green apple}] \text{ ENTAILS } \exists Y[\exists x[x \text{ ate a Y apple}]]$

The second existential in the formula on the right type-shifts the VP in (20B) so it is the right type to attach the quantifier $\exists Y$ to. To incorporate this, we define "Existential-F-Closure" as follows:

(23) Existential-F-Closure of U =_{df} the result of replacing F-marked phrases in U with variables and existentially closing the result, modulo existential type-shifting

GIVEN is now defined as:

(24) An utterance U counts as **GIVEN** iff it has a salient antecedent A and modulo \exists -type shifting, A entails the Existential-F-Closure of U

The phrase [RED]_F *apple* in (20B) now counts as GIVEN, since it has an antecedent, for example (20A) and:

John ate a green apple ENTAILS $\exists Y[\exists x[(Y \text{ apple})(x)]]$

The definition in (24) now is ready to be used in conjunction with our requirement in (19) repeated here:

(19) Non-F-marked constituents must be GIVEN.

As a way of summarizing, it might be useful to go through another example. In a discourse where *see John* has been used, *see [MARY]_F* should count as GIVEN and hence the VP itself need not be F-marked. This works as follows:

\exists -type-shifting of [see John] yields:	$\exists y[y \text{ see John}]$
Replacing F-marked part of see [MARY]_F with variable:	[see X]
\exists -type-shifting of [see X] yields:	$\exists y[y \text{ see X}]$
\exists -binding F-variables gives:	$\exists X \exists y[y \text{ see X}]$

$\exists y[y \text{ see John}] \text{ ENTAILS } \exists X \exists y[y \text{ see X}]$

In the previous section we pointed towards the need for a theory in which a non-constituent such as *John's mother praise* could count as given. This need is met in the final analysis by letting *John's mother praised HIM_F* count as GIVEN based on the discourse status of the sentence with *HIM* replaced by an existentially bound variable.

A consequence of the definition elaborated so far is that in cases of embedded F-marking, the embedded F will not be relevant above the level of the higher F. The existential

F-closure of the **sentence** *John [saw_F MARY_F]_F* will be the same as for *John [SAW_F Mary]_F*. As we shall see, however, in cases like these differences arise for the nodes below the sentence level.

In the following section, the definition of GIVEN will be carefully spelled out in a semantics where English is directly interpreted. This means, among other things, that there are no F-variables in the official theory. Nevertheless, in the remainder of the paper, I illustrate how the theory works with the help of this device along with other predicate logic style expressions used to this point.

Before formalizing the intuitions developed so far, three additional points about the definition of GIVEN need to be made. The definition makes use of two existential quantifications. The first is a type-shifter and the second binds F-variables. Only the latter is to be understood as a "real" natural language quantifier in the sense that it is restricted to a contextually relevant domain. The second point has to do with expressions of type e. Since they are not functional, they do not have arguments that an existential type shifter could bind nor is Existential-F-Closure defined for them. Both of these problems will be taken care of in the formal definition in the next section. Our final informal definition in (25) below covers only those type e expressions that do not contain F-marking in a manner more or less consistent with Rochemont(1986:49ff):

- (25) Definition of GIVEN. (Final Informal Version).
 An utterance U counts as **GIVEN** iff it has a salient antecedent A and:
- a. if U is type e, then A and U corefer.
 - b. otherwise: modulo \exists -type shifting, A entails the Existential-F-Closure of U

Finally a note on the terms "entailment" and "antecedent" used in the definition. The intention here is some kind of contextual entailment, where certain backgrounded information is assumed. Also, in the examples discussed here the relevant antecedent will be overt, but this does not preclude the possibility that a speaker could insinuate an antecedent, provided the hearer can accommodate it. To paraphrase Halliday(1967:204), the rules governing F-marking depend on what the speaker **presents** as GIVEN.

2.2 A Formal Version of the definition of GIVEN

The definition of GIVEN employs the existential type shift and Existential-F-Closure. The existential type shift applies to meanings of various types and produces meanings of type t. Following Cresswell(1973) and subsequent applications of that system to the semantics of focus, we take type t to be the type of propositions:

- (26) Existential Type Shift: ExClo
- a. If $\omega \in D_t$, then $\text{ExClo}(\omega) = \omega$
 - b. For any conjoinable type $\langle a, b \rangle$:
 If $\omega \in D_{\langle a, b \rangle}$, then $\text{ExClo}(\omega) = \lambda w \exists u \in D_a [\text{ExClo}(\omega(u))(w)]$
 - c. t is a conjoinable type.

if b is a conjoinable type, then so is $\langle a, b \rangle$, for any type a .

To see how the definition works, one can verify that if α is a meaning of type $\langle e, \langle e, t \rangle \rangle$, then $\text{ExClo}(\alpha) = \lambda w \exists u \in D_e \exists v \in D_e [(\alpha(u)(v))(w)]$.

With Existential-F-Closure, expressions of English get interpreted in such a way that F-marked expressions behave like existentially bound variables. To achieve this result, I will introduce a special assignment function, h (Kratzer 1991). h assigns meanings to indexed F-markings (the indices are omitted in much of the paper). I also adopt Kratzer's novelty condition requiring each F in a given tree to have a different index. In addition to the standard interpretation relative to an assignment function g , there is a second interpretation (Rooth 1985) relative to g and h :

(27) If α is F-marked then:

$$\begin{aligned} \llbracket \alpha \rrbracket_{F_n}^{g,h} &= h(F_n) \\ \llbracket \alpha \rrbracket_{F_n}^g &= \llbracket \alpha \rrbracket^g \end{aligned}$$

If α has no F-marking, then:

$$\begin{aligned} \llbracket \alpha \rrbracket^{g,h} &= \llbracket \alpha \rrbracket^g \text{ if } \alpha \text{ is not complex.} \\ \text{if } \alpha &\text{ has components } \beta_1 \dots \beta_n, \text{ then } \llbracket \alpha \rrbracket^{g,h} \text{ is the result of applying the semantic} \\ &\text{rule for } \alpha \text{ to } \llbracket \beta_1 \rrbracket^{g,h} \dots \llbracket \beta_n \rrbracket^{g,h} \end{aligned}$$

It follows from the first part of (27), that the phrases $[\text{saw}_F \text{ MARY}_F]_F$ and $[\text{SAW}_F \text{ Mary}]_F$ are assigned the same meanings. F-marking on a phrase renders any internal F-marking opaque for the interpretation of that phrase (though not for interpretation of subparts of that phrase).

Our definition for GIVEN can now be stated as follows:

(28) Definition of GIVEN (Formal Version)

An utterance B counts as **GIVEN** iff it has an antecedent A and:

- a. if the semantic type of B is e , $\forall \langle w, g \rangle \in c \exists h [\llbracket A \rrbracket^g = \llbracket B \rrbracket^{g,h}]$
- b. If the semantic type of B is conjoinable:
 $\forall \langle w, g \rangle \in c \exists h [\text{ExClo}(\llbracket A \rrbracket^g)(w) \rightarrow \text{ExClo}(\llbracket B \rrbracket^{g,h})(w)]$

Let A be *eat an apple* and let B be *eat a [green]_{F1} apple*. Consider now any g' , w' such that $\text{ExClo}(\llbracket \text{eat an apple} \rrbracket^{g'})(w') = 1$. In this case, w' would have to be a world in which someone ate an apple. Now, let h' be such that $h'(F1)$ is the color of an apple that was eaten in w' . In this case, $\text{ExClo}(\llbracket \text{eat a [green]_{F1} apple} \rrbracket^{g',h'})(w') = 1$. So, *eat a [green]_{F1} apple* counts as GIVEN in a discourse where *eat an apple* is salient for it.

Although I have borrowed formal devices from analyses of association with focus, the final outcome is somewhat different from what one finds in those sources. The taxonomy of focus-meanings discussed in Rooth(1985:17), based to some extent on Jackendoff(1972), will

help clarify the differences. (27) uses **Presups** which are logical forms where F-markers are treated as variables. Kratzer(1991) uses the Presup of an expression to define its **p-set** which is a set of meanings of the same type as the expression itself. Alternative Semantics (Rooth 1985/95) defines p-sets in a different way, but the type of object is the same. In (28), on the other hand, presups are not used to define sets, instead they define propositions. Let us call these ExClo propositions. If the F-marked expression (roughly B in (28)) is itself of propositional type, then its ExClo proposition is equivalent to **the existential closure of Presup**. The existential closure of Presup is just the disjunction of the elements of the p-set and this too is claimed to play a role in association with focus (Rooth 1985, Krifka 1992, von Stechow 1994). However, for expressions not of propositional type, the existential closure of Presup and the ExClo proposition are not the same. The former is not a proposition. This difference becomes important when the F-marked expression and its antecedent are of different type. This circumstance is possible because (28) effectively raises both the antecedent and the target to the same propositional type. Perhaps the clearest example where this is necessary will come in section 3.3.2, where a declarative is the antecedent for givenness in a subsequent interrogative.

The definition in (28) treats GIVENness in terms of anaphora and entailment. In this respect, it follows the analysis of contrastive focus in Rochemont (1986:chapter 2). By limiting the worlds of evaluation to those in context *c*, we allow for the possibility that the entailment may depend on background assumptions shared by the participants in the conversation (van Deemter1994:25). This is illustrated in the following dialogue similar to one suggested to me by Satoshi Tomioka:

- (29) {A. John got the job. }
 B. I KNOW. they WANTED a New Yorker

Here *New Yorker* is treated as GIVEN. Intuitively, for this to work, the conversants would have to know that John is a New Yorker. A's utterance entails, relative to that assumption, that there is a New Yorker. Exactly which propositions count as in the background for these purposes remains to be worked out.

The assignment function *g* will, among other things, be used to interpret indexed pronouns. This will mean that a pronoun will count as GIVEN if it has an antecedent with the same index. As observed in the examples so far, we would like a pronoun to count as GIVEN if it has a coreferent antecedent which is non-pronominal. This means that our semantics should entail for example that in a context *c*, where he_i follows $John_i$, $[John_i]^g = [he_i]^g$, for any *g* in *c*. On this view, indices are relevant to givenness. There are delicate issues here that remain to be worked out including bound pronouns and indefinites (cf. discussion in van Deemter 1994). Even though it bears a new index, the second occurrence of *a donkey* is not accented in (30a):

- (30) a. If a MAN owns a DONKEY_{*i*}, his WIFE owns a donkey_{*j*}.
 b. If a MAN owns a DONKEY_{*i*}, his WIFE owns a MULE_{*j*}.

This would follow if, indefinites were treated as existentials and their indices were irrelevant for GIVENness. In that case, the first occurrence of *a donkey* would count as an antecedent for the second.

We end with an observation about quantificational NPs in this system. According to (26-28), a noun phrase meaning v of type $\langle\langle e,t \rangle, t \rangle$, will count as GIVEN, if it has some salient antecedent which entails $\exists P[v(P)]$. Consider the noun phrase *no man*. In any world, w , there will be some property that is true of no man, even if there are no men. *no man* will therefore count as GIVEN in any context. Similarly, in any world, there will be some property that every man in that world has, even if there are no men. So *no man* as well as *every man* and other strong quantifiers count as GIVEN in any context. On the other hand, nothing guarantees that there is some property that some man, or six men have in any world w , so existential NPs are not automatically GIVEN. Leaving aside *no man*, this result yields an interesting division of NPs into those that are always GIVEN (=strong) and those that aren't (=weak). This might then play a role in the definiteness effect (Zucchi 1995 and references therein). It should be noted however, that this doesn't translate into the prediction that strong NPs should never contain F-marking. *every man* might be GIVEN, but *man* may not be, hence it would be F-marked. Furthermore, *no man*, might be GIVEN, and *walks* might be GIVEN, but it still could be the case that *no man walks* is not GIVEN, requiring F-marking somewhere in the sentence.

3. AVOID F & GIVENNESS

3.1 Introducing the Constraints

At this point, we are assuming the syntax of F-assignment as in Selkirk(1996), repeated below:

(31) **F-Assignment Rules**

Basic F Rule

An accented word is F-marked.

F Projection

- (a) F-marking of the *head* of a phrase licenses the F-marking of the phrase.
- (b) F-marking of an *internal argument* of a head licenses the F-marking of the head.

And we are assuming the constraint in (32) below³:

(32) **GIVENness**
If a constituent is not F-marked, it must be GIVEN.

This rule accounts for the distribution of F-marking in the following example:

- (7) {What did Mary do?}
A: She [[praised]_F [her [BROTHER]_F]_F]

Since *brother* is not GIVEN in the answer, it must be F-marked otherwise it would violate GIVENness and likewise for the other F-marked constituents. To see that (32) is not enough, however, we need to compare (7) to our other earlier example (9):

- (9) {What did John_i's mother do?}
A: She [[PRAISED]_F him_i]_F.

Why is the object NP in the answer normally not F-marked? The constraint in (32) is of no help. It cannot prevent F-marking since it doesn't have anything to say about F-marked constituents. One is tempted to propose the complement of (32), along the following lines:

- (33) **NOVELTY** (tentative)
If a constituent is F-marked, it must not be GIVEN.

But there are counterexamples to this rule, such as the pronoun in our earlier example:

- (11) Who did John's mother praise?
A: she praised [HIM]_F

This is what forced Selkirk into restricting the application of (33) to embedded F-markings.

Instead of adopting (33) with the ad-hoc restriction added to it, I want to suggest an alternative view of what is going on in (9). As far as GIVENness is concerned, *him* in (9) doesn't need to be F-marked. What (9) shows then is that when F-marking is not needed, it is avoided. This leads to the following alternative⁴ to (33):

- (34) **Avoid F**
F-mark as little as possible, without violating GIVENness.

On this alternative, nothing commits us to any particular interpretation of F-marking and so (11) is not an obvious counterexample for Avoid F as it was for (33). Lack of F-marking of *him* in (9) is now explained, it remains to show why *HIM* in (11) has to be F-marked.

3.2 Interrogatives

In a moment we will explain the presence of F-marking in the answer in (11) below, on the basis of the constraints in (32) and (34):

- (11) Who did John's mother praise?
A: she praised [HIM]_F

- (32) **GIVENness**
If a constituent is not F-marked, it must be GIVEN.

- (34) **Avoid F**
F-mark as little as possible, without violating GIVENness.

In order to do that, we will need to consider the interrogative or parts of the interrogative as GIVENness antecedents for the answer or parts of the answer. This means that we need to think about the existential closure of the interrogative. I will show in the following subsection that the existential closure of an interrogative is just the result of replacing Wh-expressions

with indefinites. So the existential closure of the interrogative in (11) is the proposition that John's mother praised someone.

3.2.1 *The Existential Closure of Interrogatives.*

3.2.1.1 *Karttunen's question meanings*

According to Karttunen(1977), the meaning of an interrogative is a set of true propositions that answer the question. On this view, *who saw Bill* denotes the set of true propositions from among propositions such as: that John saw Bill, that Hilary saw Bill, that Monica saw Bill and so on. The definition of GIVEN relies on existential type shifting to shift meanings to propositional type and then uses these meanings in entailment relations. Since questions are not propositions, they too will be type shifted. For *who saw Bill*, the result will be a proposition according to which there is some element in the set of true propositions of the form 'X saw Bill'. There can only be a true proposition of this form if someone actually saw Bill. This result generalizes to other Wh-questions, as summarized below:

(35) The existential closure of an interrogative of the form: $Q_i[{}_{CP}\dots t_i\dots]$, is roughly $\exists x_i[{}_{CP}\dots x_i\dots]$

It should be pointed out that the results of this section do not imply that interrogatives carry existential presuppositions. The only claim made here is that for the purposes of GIVENness, interrogatives create contexts similar to those created by existential statements.

3.2.1.2 *A Formalization*

Karttunen(1977) works in the system of PTQ where sentences denote truth values and interrogatives denote sets of propositions. Adapting his analysis to the framework of section 2.2, we have sentences denoting propositions and interrogatives denoting functions from propositions to propositions. For example, (36a) would have the meaning given in (36b):

(36) a. Who saw Bill?
b. $\lambda p \exists x [p \ \& \ p = \text{saw}(x,b)]$

The result of applying (36b) to a proposition q is a proposition that is true just in case q is true and for some X , q is the proposition that X saw Bill.

Applying ExClo , defined in (26) above, to the meaning of (36b) we get:

$\text{ExClo}([\text{36b}]^g) = \lambda w \exists u \in D_t ([\lambda p \exists x [p \ \& \ p = \text{saw}(x,b)]]^g(u) (w))$

so:

$\text{ExClo}([\text{36b}]^g) = \lambda w \exists u \in D_t ([\exists x [p \ \& \ p = \text{saw}(x,b)]]^{g[u/p]} (w))$

which picks out the same worlds as $\exists x [\text{saw}(x,b)]$

Note: $\llbracket \exists x \Phi \rrbracket^g$ denotes a proposition which is true in any world w , just in case, $\llbracket \Phi \rrbracket^g(w) = 1$, for some g' like g except for its assignment to x .

3.2.2 Answers to Wh-Questions

Turning now to the answer in (11):

- (11) {Who did John's mother praise?}
A: she praised $[HIM]_F$

The following two questions arise in connection with GIVENness and Avoid F:

- (37) (i) Why is F-marking allowed on *HIM*? Since *HIM* is GIVEN, shouldn't this be an unjustifiable violation of Avoid F? (as in (9A) above)
- (ii) Why is F-marking required on *HIM*?

The first question is often answered in the literature by taking the prominence on *HIM* to fall into a different category from what we have been discussing. Rochemont(1986) calls this "contrastive focus" as opposed to "presentational focus" which is sensitive to givenness. The second question is often answered by appealing to a special rule of focussing in question/answer pairs, requiring the piece of the answer corresponding to the *Wh*-phrase to be focussed. As noted above, such a move is not without its problems.

Fortunately, careful consideration of the combined effects of GIVENness and Avoid F renders both of these amendments superfluous. Observe, first, that GIVENness is not violated in (11). Checking all non-F-marked constituents we have:

- (38) IP: she praised $[HIM]_F$ is GIVEN because:

$\exists y[\text{John's mother praised } y] \text{ ENTAILS } \exists X[\text{she praised } X]$
existential closure of interrogative

VP: [praised $[HIM]_F$] is GIVEN because:

$\exists y[\text{John's mother praised } y] \text{ ENTAILS } \exists X \exists y[y \text{ praised } X]$
existential closure of interrogative

[praised] is GIVEN because:

$\exists y[\text{John's mother praised } y] \text{ ENTAILS } \exists x \exists y[y \text{ praised } x]$
existential closure of interrogative

HIM and *she* are both GIVEN on the intended readings, because they have antecedents with which they corefer.

Turning to Avoid F, we now need to consider the consequences of leaving the F-marking off the object noun phrase:

- (39) {Who did John's mother praise?}
A: *[she praised him]

In this case, we run into several violations of GIVENness:

- (40) IP: [she praised him] is not GIVEN because:

$\exists y$ [John's mother praised y] doesn't *ENTAIL* [she praised him]
existential closure of interrogative

VP: [praised him] isn't GIVEN because nothing entails $\exists y$ [y praised him]

It turns out that if the F-marking is left off of *HIM*, GIVENness is violated, hence having the F-marking there does not constitute a violation of Avoid F. We have answered our first question, namely why is F-marking is allowed on *HIM* and we have gone part of the way towards answering why it is required. It remains to show why F-marking has to be on *HIM* and not somewhere else. Let's consider our options:

- (41) {Who did John's mother praise?}
A: *[SHE_F praised him].

(41) is ruled out because the IP violates GIVENness since nothing entails: $\exists Y$ [Y praised him]. Incidentally, consideration of this case shows that it will not suffice to simply say that F-marking is required on a constituent that is "unpredictable in a particular sentence-position" (Prince 1981:228). In this discourse, *she* is no more predictable as the subject of *she praised him* than *him* is as the object (see also footnote 4, example ii). (42) represents another possibility:

- (42) {Who did John's mother praise?}
A: *[she PRAISED_F him].

Again in this case, the IP violates GIVENness since nothing entails: $\exists R$ [John's mother R-ed him]⁵. A different kind of alternative to (11A) is the following:

- (43) {Who did John's mother praise?}
A: *she [[PRAISED]_F him]_F.

In this case, there is no violation of GIVENness. *HIM* and *she* are not F-marked and they are GIVEN. The whole sentence is not F-marked, but it is GIVEN because:

$\exists y$ [John's mother praised y] *ENTAILS* $\exists X$ [she Xed]
existential closure of interrogative

(43A) is not in fact ruled out by GIVENness. Instead, it is ruled out by Avoid F, since it has more F-marking than the GIVENness satisfying alternative (11A):

- (11) {Who did John's mother praise?}
 A: she praised [HIM]_F

3.2.3 Summary

According to Avoid F, F-marking is used sparingly and in a way that preserves a perfect correlation between GIVENness and lack of F-marking. This entails that an expression which is entirely new in the discourse will have to be F-marked. It does not entail that whenever an expression is F-marked it represents new information. Exceptions arise because old parts can be assembled in new ways. In such cases, broad F-marking would miss the fact that some parts are old. Complete lack of F-marking would destroy the correlation with GIVENness. Equilibrium is reached by F-marking just enough to preserve the correlation and nothing more.

The current theory predicts the pattern of F-marking in (11) without having to invoke any special kinds of focus or an independent rule of accent placement in question/answer pairs.

Selkirk's stipulation that a novelty interpretation applies only to embedded F-markers can now be explained. Compare the answers in our two examples:

- (11) {Who did John's mother praise?}
 A: she praised [HIM]_F

- (9) {What did John's mother do?}
 A: She [[PRAISED]_F [him]]_F.

In (11A), the VP and IP are not F-marked and it is their interpretation as GIVEN that requires F-marking of *HIM*. In (9A), the VP is F-marked, hence the only thing that could force *him* to be F-marked is its being novel in the discourse. It follows then that in a constellation of the form: [[head]_F [X]_F]_F, X must be interpreted as novel.

3.3 Other Results

3.3.1 Q/A Puzzle Revisited.

(12) was used to show that the part of an answer that corresponds to the *Wh*-phrase in the question is sometimes not F-marked:

- (12) {John drove Mary's red convertible. What did he drive before that?}
 A: he drove her [BLUE]_F convertible.

On the current analysis there is no rule of F-marking in question/answer pairs. This permits us to capture the intuition that the F-marking of (12A) is the result of prior context. All the non-F-marked parts are GIVEN⁶, as follows:

John drove Mary's red convertible. *ENTAILS*

- a. NP: $\exists X \exists P [P(\text{her } X \text{ convertible})]$
- b. VP: $\exists X \exists y [y \text{ drove her } X \text{ convertible}]$
- c. S: $\exists X [\text{he drove her } X \text{ convertible}]$

Moreover, the F-marking on *BLUE* could not be omitted and any other F-marking would involve more F-marking than is already there, so Avoid F is satisfied.

3.3.2 Answer/Question Pairs

The theory proposed here for how to account for the F-marking in answers, extends to the F-marking in interrogatives, as the following illustrates:

- (44) {I bought a watch for my younger sister.}
What did you buy for your [OLDER]_F sister?

The F-marking in the interrogative is in keeping with GIVENness. The interrogative itself is not F-marked, but it is GIVEN:

[I bought a watch for my younger sister]
ENTAILS
 $\exists X \exists y [I \text{ bought } y \text{ for my } X \text{ sister}]$

Avoid F prevents further F-marking of the interrogative, while GIVENness prevents the omission of the F on *older*.

3.3.3 Yes/No Questions

For the purposes of GIVENness, yes/no questions behave like their declarative counterparts (cf. *Did John leave? no, [Mary]_F left*). However, on Karttunen's theory, the yes/no question *Did John leave?* denotes the set containing the proposition that John left and the proposition that John didn't leave. In this case, the existential type-shift of the question is a tautology: at least one of those propositions always has to be true. Since a tautology entails only other tautologies, on this view, yes/no questions are generally irrelevant as GIVENness antecedents.

According to Bäuerle(1979), the yes/no question *Did John leave?* denotes a set containing the proposition that John left, if in fact John left, and otherwise it denotes the empty set. The idea is that the yes/no question *Did John leave?* behaves semantically like a restricted Wh-question, (*Who left, John?*). Now, if there is an element in the set denoted by *Did John leave?* then John left. So the existential type-shift of *Did John leave?* is the proposition that John left.

This analysis may be useful in accounting for Bäuerle(1979)'s observation that:

- (45) Did [JOHN]_F leave?

asks about who is leaving (\approx *Who left, John?*), whereas:

(46) Did John [LEAVE]_F?

asks about John, (\approx *What did John do? leave?*).

we can sketch the contribution of the question in (45) to GIVENness as follows:

Replacing F-marked part of **Did [JOHN]_F leave?** with variables: **Did X leave?**

\exists -type-shifting of **Did X leave?** yields: **X left**

\exists -binding F-variables gives: **$\exists X[X \text{ left}]$**

(45) requires an antecedent that entails $\exists X[X \text{ left}]$ and so *Who left?* is a possible antecedent. On the other hand, (46) requires an antecedent that entails, $\exists X[X(\text{John})]$, and in this case *What did John do?* would work. Karttunen's theory on the other hand, predicts these two to have the same existential closure hence the same type of antecedent would be required, namely one that entailed a tautology.

3.3.4 Assertion/Contradiction Pairs.

The F-marking in the contradiction in (47) works as in the question/answer pairs above:

(47) John's mother praised Bill.
no, John's mother praised [JOHN]_F

F-marking on *JOHN* doesn't indicate novelty. Rather, it is the minimal F-marking that allows non-F-marked constituents to be interpreted as GIVEN and as such it is required. The F-marking facts are similar when one speaker adds to another's assertion:

(48) John's mother praised Bill.
she also praised JOHN.

Assuming *also* doesn't add to the truth conditions of the response, and hence is irrelevant to any GIVENness calculations, (48) works like (47).

4. THE INTERPRETATION OF FOCUS

By establishing givenness as the mainstay of our theory, we break ranks with those who assume that focus provokes interpretation. This point is nicely illustrated by comparing the GIVENness Constraint with the Focus Interpretation Operator of Rooth(1992) which is similarly cross-categorical and similarly requires an antecedent semantically like the phrase it is adjoined to, except for the F-marked parts (the Focus Interpretation Operator is stricter than the GIVENness Constraint in requiring type similarity with the antecedent, see section 2.2).

First, as is appropriate for a device whose job it is to assign an interpretation to a focus, the Focus Interpretation Operator cannot felicitously adjoin to material that contains no F marking. The GIVENness Constraint, on the other hand, can and absolutely must apply to

F-less material. If it didn't, Avoid F would eliminate all F-markers. Secondly, only one Focus Interpretation Operator can interpret a focus. This too makes sense: once a focus has received its interpretation, there is nothing more to do. The GIVENness Constraint, on the other hand, can apply to successive nodes of a tree and each time the same F-marker can 'remove' material from the phrase being interpreted (by the rules in §2.2). The GIVENness Constraint and the Focus Interpretation Operator were constructed with different functions in mind and with different views of how the grammar works. Even so, both appeal to "anaphoric recoverability" and both treat F-markers as variables in a secondary interpretation.

Rooth(1992:§10) and Truckenbrodt(1995:§4) make an interesting argument for the Focus Interpretation Operator. They claim that the level at which it is adjoined has phonological consequences. Whether or not that constitutes an argument against our framework depends in part on whether the relevant information is available in the representations assumed here, generated by the F-assignment rules. (49) below is once such representation:

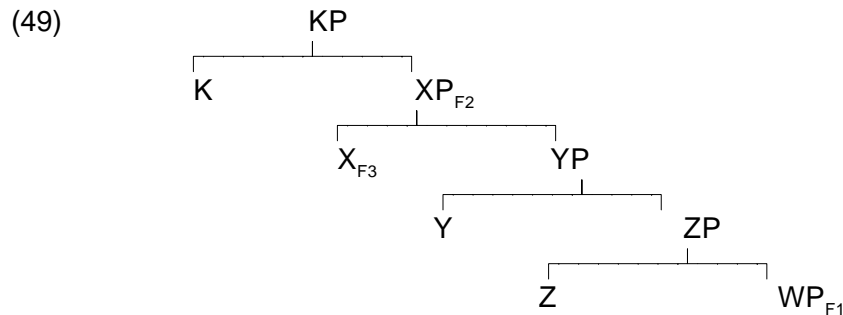

The GIVENness Constraint applies to YP requiring an antecedent like YP except for the material in WP. The GIVENness Constraint applies as well to KP, but F1 no longer plays a role in the requirement it imposes, due to the presence of F2. This state of affairs would be captured under the focus interpretation view, by adjoining a focus interpretation operator to YP and none below it. In this manner, F1 would get interpreted at YP but not higher. In general, the focus interpretation approach adjoins an operator above an F-marker at the site of the highest dominating F-less node reached without traversing any F-marked nodes. Any phonological effects attributed to the level of adjunction of a focus interpretation operator would be here understood as effects of a higher F marker. For F1, in (49), the level is set by F2. By allowing for embedded F-marking, Selkirk has already provided for the marking of the "domain of a focus", as Truckenbrodt calls it. There is one caveat. Judging from examples in the literature, the adjunction site of a Focus Interpretation Operator does not appear to be constrained in the way that the rules of F-assignment constrain F-marking (F2 wouldn't be licensed if F3 was not present). This problem will evaporate once the F-marking rules are changed in section 6.

5. ON THE ROLE OF RHETORICAL RELATIONS

The GIVEN relation is a species of anaphora. As such, rhetorical relations play a role in the choice of an antecedent for an anaphor. The following example illustrates this:

- (50) {John borrowed the book that Max had purchased.}
 a. no, MAX_F borrowed it.
 b. no, Max BORROWED_F it.

Both a. and b. are possible in the context provided in (50), nevertheless, there is a difference. Even though a. and b. have the same content, the first is taken to contradict the main clause assertion that John did the borrowing, while b. contradicts the information contained in the relative clause. We can make sense of the F-marking by assuming that whether or not an expression A is salient for B depends on the rhetorical relations that hold between them. If one means to contradict the relative clause in (50), then only that clause will be salient and hence the F-marking must be as in b. On the other hand, if one is contradicting the main clause, then in fact either F-marking should be possible, since the main clause entails both that someone borrowed the book and that Max bore some particular relation to the book. Apparently, a. is chosen because it unambiguously requires the main clause as an antecedent.

One finds a similar situation in the following example:

- (51) {Who did Mary's attacker invite?}
 i. {actually,} he DEFENDED_F her.
 ii. He invited MARY_F.
 iii. *He INVITED_F Mary.

The response in i. is addressed to the information in the noun phrase *Mary's attacker*. That noun phrase entails that he attacked Mary and so the reply is F-marked in a way that calls for an antecedent which entails that the alleged attacker bears some particular relation to Mary. ii. and iii. are meant to be construed as replies to the question. ii. is the choice in this case, since it allows only for the interrogative to be the antecedent, while iii. allows for the interrogative or the noun phrase *Mary's attacker*.

A reviewer noted another situation where this principle comes into play. Consider the following discourse fragment:

- (52) {Q. Did Karen get the money or did Marc get the money?}
 A. KAREN_F got the money.
 A'. *Karen got the MONEY.

The interrogative denotes the set of true propositions from among the ones expressed by *Karen got the money* and *Marc got the money*. The existential type shift of this set gives us the proposition that Karen or Marc got the money. Taking this as the antecedent for the purposes of GIVENness in (52A), we get the right results. The problem is that if the first disjunct is taken as the antecedent, we predict there should be no F-marking. In other words, with that antecedent, (52A') is just as good as (52A), possibly better depending on what defaults apply when there is no F-marking. Apparently, since (52A) is taken to answer the question, the question serves as its GIVENness antecedent.

6. INFORMATION STRUCTURE AND SYNTAX.

The issues addressed in this paper lie at the interface of syntax, semantics and phonology. Up to this point we have been concerned mainly with the interpretive ends of interface. We have taken for granted the purely syntactic rules of F-Projection stemming from Selkirk(1984) and Rochemont(1986), repeated here:

(6) **F-Assignment Rules**

Basic F Rule

An accented word is F-marked.

F Projection

(a) F-marking of the *head* of a phrase licenses the F-marking of the phrase.

(b) F-marking of an *internal argument* of a head licenses the F-marking of the head.

The Basic F Rule treats a pitch-accent as a morpheme which appears on a word having a feature, F. On this view, the rule in (6a) is an instance of feature percolation (see Rochemont 1986:§3.1). The rule in (6b) is meant to capture asymmetries observed between heads and arguments. Whereas an unaccented argument must be GIVEN, not every unaccented head is GIVEN. This asymmetry has been conceived of in various ways: via "integration" (Jacobs 1991), relative stress of phrases over non-phrases (Truckenbrodt1995, Cinque1991), formation of focus domains (Gussenhoven 1984,1992). The rule in (6b) takes it to be the result of F-Projection, and therefore a purely syntactic phenomenon.

Below we will see evidence that the system of F-projection, while harmless for the examples studied so far, is in fact too restrictive. I will argue that the rules of F-Projection in (6) are simply wrong and that:

(53) F-marking is syntactically unconstrained.

The move from the Selkirk/Rochemont system to the claim in (53) leaves important questions open. What is the relation between F-marking and accent placement in general and more specifically, how should we understand the head/argument asymmetry? What we will see is that this asymmetry persists even in cases where F-marking plays no role in the pattern of accent placement. This leads to the conclusion that the asymmetry should be captured in the syntax-phonology portion of the interface, as in older accounts of focus and stress. A preliminary sketch of how accent and F-marking interact will include the Basic F Rule along with a violable constraint favoring prominence of an argument over its head.

6.1 *Projection is too Constrained*

The rules of F-Assignment define possible paths from an accented word up to an F-marked c-commanding or dominating node. We would like to show that these rules are too restrictive by demonstrating that a phrase could be F-marked without there being an F-marked path down to an accented word in that phrase. To construct such a case, we need to keep in mind two points illustrated by example (7) which is F-marked in accordance with the F-assignment rules:

- (7) {What did Mary do?}
 A: She [[praised]_F [her [BROTHER]_F]_F]

First, observe that there is redundancy in the semantic and syntactic constraints on F-marking. F-marking on many of the nodes in this example are needed both to satisfy GIVENness, as well as to provide a node in a path up to a higher F-marker. F-marking on *brother* is necessary, because *brother* is not GIVEN, but it is also necessary to provide the source for licensing the F-marking of the verb. If an F marker is independently needed for GIVENness, its presence is not an argument for F-Projection. The second point is that not all F-marked nodes dominate an accented word, so that it is not always possible to know if a word is F-marked or not. Under these circumstances, to show that the rules of F-assignment are too restrictive, we need to find an example with a node X having the following properties. Node X is GIVEN hence it doesn't by itself need F-marking. A dominating node Y is not GIVEN, so it requires F marking, and the projection path for the F-marking of Y goes through X. Finally the F-marking of X entails the presence of an accent that wouldn't otherwise be necessary.

The following case, similar to one in Büring(1996), presents itself:

- (54) {Jack said the American President drinks. What did Gilles_i say?}
 a. he_i said the FRENCH President drinks.
 b. HE_i said the FRENCH President drinks.

The bracketed question in (54) can be answered as in (54a) or (54b). The answer in (54a) is the problematic one. The discourse requires, and the phonology justifies, an F-marker on *French* in (54a), giving us:

- (55) {Jack said the American President drinks. What did Gilles_i say?}
 he_i said the [FRENCH]_F President drinks.

F Projection rules do not allow for any higher F. Since *President* is not accented, it could not be F-marked via the Basic F Rule. Since *French* is not the internal argument of *President*, we must conclude that *President* is not F-marked at all. This prevents any F-marking of higher phrases via projection and since no other word is accented, we can conclude that there are no other F-markers. Turning to the semantics, since the entire answer is not F-marked it must be GIVEN, requiring an antecedent that entails that Gilles said the X President drinks, for some X. Since nothing in the discourse entails Gilles said anything in particular, (55) is erroneously predicted to be infelicitous.

It is important to note that the problem arises on the level of the higher sentence node and not earlier. In particular, the embedded clause and the main verb phrase are both GIVEN in the discourse. They both have antecedents in the preceding utterance of *Jack said the American President drinks*. Furthermore, the main clause itself would be felicitous if there was an F-marker on either of these lower nodes:

- (56) {Jack said the American President drinks. What did Gilles_i say?}
 a. he_i [said the [FRENCH]_F President drinks]_F.
 b. he_i said [the [FRENCH]_F President drinks]_F.

Following the results of section 3.2.1, the existential closure of the question *What did Gilles say?* is the proposition that Gilles said something. This is just what is required for the top node of (56b) to count as GIVEN (compare (38) above):

(57) IP: he_i said [the [FRENCH]_F President drinks]_F is GIVEN because:

$\exists y[\text{Gilles}_i \text{ said } y] \text{ ENTAILS } \exists X[\text{he said } X]$
 existential closure of interrogative

VP: said [the FRENCH_F President drinks]_F is GIVEN because:

$\exists y[\text{Gilles}_i \text{ said } y] \text{ ENTAILS } \exists X \exists y[y \text{ said } X]$
 existential closure of interrogative

(56a) is similarly felicitous in this discourse. (58) below is yet another representation that satisfies GIVENness in this context.

(58) [he_i said the FRENCH_F President drinks]_F.

The representations in (56a-b) and (58) differ by the amount of material covered by an F marker. Avoid F presumably chooses (56b) as the representation of the utterance in this context, since in that case the least material is covered by an F-marker. Since the utterance is in fact felicitous in the discourse we conclude that (56b) must be generated by the grammar. This conclusion entails that we abandon the rules of F-Projection. The strongest claim we can make is that F markers are freely assigned, subject to the Basic F Rule and the demands of GIVENness and Avoid F.

6.2 Heads and Internal Arguments

By allowing for F-marking to be syntactically unconstrained, we lose the explanation provided by the Projection Rules for asymmetries in the accenting of heads and arguments (henceforth HA). According to the Projection account of (7):

(7) {What did Mary do?}
 A: She [[praised]_F [her [BROTHER]_F]_F]

both the head (*praised*) and the argument (*her brother*) are F-marked, however only the F-marking on the argument entails the presence of a pitch accent. On this account and on others like it, HA follows from the relation between accent and information structure.

There are two possible situations whose existence would be problematic for this view (see also Truckenbrodt 1988). First, there are cases of HA where neither the F-marker on the head nor the F-marker on the argument entails an accent. In such a case, HA could not follow from the demands of F-marking. Second, HA is found even when the discourse doesn't require F-marking of either the head or the argument. In both situations, the F-marking/accent relation is silent on the position of accent, hence the asymmetry observed must arise elsewhere. We will argue that both situations exist and that the source for HA is a violable constraint to the effect that:

(59) A head is less prominent than its internal argument(s).

6.2.1 FOC *versus* F

Compare the following to example (7) immediately above:

(60) {John cited Mary} but he DISSED_{F1} SUE_{F2}.

while the verb may be accentless in (7), it cannot be in (60).⁷ Since in both cases the verb is followed by an F-marked object, the F-Projection rules are of no help here. The crucial difference, it seems, is that in (60) the F on the verb is not immediately dominated by another F-marked node. Adapting terminology from Selkirk(1996), we define:

(61) An **Foc** marked node is an F-node that is not immediately dominated by another F-marked node.⁸

Ordinary F-marking doesn't entail accentuation, however:

(62) Foc marked material must be accented.

This captures the difference between the verbs in (7) and (60). It also explains the pattern of accenting in the following case, which arises under free F-marking:

(63) {What will they do if the American President resigns from the OSA?}
they'll [nominate_{F1} the FRENCH_{F2} President]_{F3}.

Neither *nominate* nor *French* are GIVEN, hence they are F-marked. If the VP was not F-marked, an antecedent would be required having a meaning expressed by "they'll X Y" for some X,Y (Y may be further restricted depending on whether or not the NP is F-marked). Since no such antecedent is available, the VP is F-marked. Crucially, the object NP need not and hence by Avoid F may not, be F-marked, since it has an antecedent in *the American President*. Having explained the pattern of F-marking, the pattern of accenting follows immediately from (61-62). *French* is Foc-marked, hence it requires accent, *nominate* is not Foc-marked. This kind of example cannot be handled by the Projection Rules, as is made clear by the discussion in Rochemont(1986:75, fn.75). In that theory, the accent on *French* cannot license F-marking of the object. And since the internal argument of *nominate* is not F-marked, its F-marking erroneously entails accenting.⁹

Returning to (7), by (62), the VP must contain an accent, since it is Foc-marked. The Basic F Rule allows either the verb or the noun to carry the accent. If only one of them is to contain an accent, the constraint in (59) says it must be the noun. HA does not directly result from F-marking rules.

6.2.2 All GIVEN **Foc** phrases

This next argument will require a complex example, so we will do well to establish the F-marking of simple cases, before proceeding with confidence to the critical example.

Consider first an example where an NPs 'moves' between subject and object position:

- (64) {John telephoned Mary, and then:}
a. [MARY]_F telephoned [SUE]_F
b. [SUE]_F telephoned [JOHN]_F

In (64a,b), *Sue* is not GIVEN, hence it is F-marked. In (64a), *Mary* must be F-marked, because nothing entails that Mary telephoned someone. Nothing else needs to be F-marked. In (64b), *John* needs to be F-marked, because *telephoned John* is not GIVEN. No further F-marking is necessary.

In the next example, we are interested in the prominence within the subject and object NPs.

- (65) [the rising of the TIDES] depends upon [the MOON being full]

I have omitted F-marking here, but this is to be understood as an out of the blue utterance, so everything is F-marked. The accent placement within the subject NP is straightforward. *the tides* is more prominent than *rising*, because it is the argument and *rising* is the head. The same situation obtains in the object NP, if we assume that *the moon* is the internal argument of *being full*. Such an assumption is consistent with much work in this area (Selkirk 1996, Gussenhoven 1992, Rochemont 1998 and references therein). Incidentally, these kinds of examples were important in establishing that an NSR type rule is not viable: due to the way argument structure works in English, prominence is usually rightmost, but not always. Now, consider the following continuations of (65):

- (66) {the rising of the TIDES depends upon the MOON being full, and}
[the MOON being full]_F depends upon [the position_F of the SUN_F]_F
(67) {the rising of the TIDES depends upon the MOON being full, and}
[the BOAT_F being empty_F]_F depends upon [the rising of the TIDES]_F

In either of these examples, F-marking works like in (64a,b). In each case, both the new NP and the 'moved' NP are F-marked. GIVENness doesn't require any further F-marking within the 'moved' NPs, nevertheless the position of accent in these phrases continues to be determined by argument structure. This is surprising for an account in which argument structure constrains F-marking and F-marking determines accent placement. On the theory being sketched here, the F-markers on the moved NPs are Foc, hence they require accent. Assuming the Basic F Rule, there is no place to put the accent in these cases. To satisfy the requirement of accenting Foc marked material, we must incur a violation of Avoid F. We need to F-mark some word in each of these NPs, but which word? The constraint on argument/head relative prominence (59) determines that it should be the argument, giving us:

- (68) [the MOON_F being full]_F depends upon [the position_F of the SUN_F]_F
(69) [the BOAT_F being empty_F]_F depends upon [the rising of the TIDES_F]_F

6.3 Ranking Constraints

Our central claim in this section is that F-marking is syntactically unconstrained. This means that F-Projection is untenable and an alternative account of how F-marking controls accent placement is required. In spelling out this alternative a number of constraints have been introduced. This suggests the beginnings of an Optimality Theoretic (Prince and Smolensky 1993) account in which constraints are violable and ranked with respect to one another. Our current collection of constraints are listed below, some in slightly modified form:

(70) **GIVENness** A constituent that is not F-marked, is GIVEN.

Avoid F Do not F mark.

FOC An Foc marked phrase contains an accent

HeadArg An head is less prominent than its internal argument.

The form of the last two constraints will probably change once they are properly incorporated in an theory of prosody which takes account of stress and phonological phrasing (cf. Pierrehumbert 1993, Truckenbrodt 1995)¹⁰. Such a theory will guarantee that accented syllables are more prominent than unaccented ones, something assumed above in appealing to HeadArg. The form of FOC bears further discussion, which I defer for the moment. Assuming these constraints, such as they are, our discussion entails the following rankings (A>B indicates that A outranks B):

- | | | |
|------|--------------------|---|
| (71) | GIVENness > AvoidF | The opposite ranking predicts we should never see any F marking at all. |
| | FOC > AvoidF | This ranking was just appealed to in discussion of examples (68-69). |
| | AvoidF > HeadArg | The opposite ranking would predict there would be no 'deaccenting' in examples like (9), (<i>What did John's mother do?</i>) <i>She</i> [[PRAISED] _F <i>him</i>] _F). |

These rankings are consistent and partial. GIVENness and FOC are not ranked relative to one another. I cannot think of any empirical consequences of either ranking. This may be because they are part of different modules of the grammar. GIVENness is a pragmatic/syntactic constraint while the remaining three could be thought of as defining the syntax/phonology part of the equation. Possibly GIVENness factors into determination of the candidate set evaluated by the other constraints. In that case, it would not be ranked relative to Avoid F, nevertheless the net effect would be the same, though different predictions are made concerning the typology of languages. Leaving GIVENness out, our rankings add up to:

(72) FOC > AvoidF > HeadArg

The Basic F Rule is not included. It too is assumed to apply outside this system, though this is not necessary. Finally, as noted in (71), the relative ranking of AvoidF and HeadArg gives rise to deaccenting. This suggests a possible reranking of these constraints in languages that

are claimed not to deaccent (Ladd 1996, Vallduví and Engdahl 1996).¹¹

6.4 To F or not to F?

The constraint Foc makes reference to Foc-marked phrases, where Foc is defined as:

- (61) An **Foc** marked node is an F-node that is not immediately dominated by another F-marked node.

The subset of F-markers picked out by this definition looks disturbingly arbitrary, until one considers how they are interpreted. In determining GIVENness for the constituents of (63):

- (63) {What will they do if the American President resigns from the OSA?}
they'll [[nominate]_{F1} the [FRENCH]_{F2} President]_{F3}.

there comes a point at which *h*, the function that assigns values to F-markers, must assign to F₂ the meaning of *American*. This is required to verify the GIVENness of *the French*_{F₂} *President*. In order to verify the GIVENness of the whole sentence F₃ gets assigned the meaning of *what/something*. F₁, on the other hand, never needs to get assigned any value. Generalizing, Foc markers, like F₂ and F₃, are assigned meanings from prior discourse, while ordinary F markers are not. This explains Selkirk's original insight that Foc-marked phrases correspond to alternatives in the discourse. The Foc/F distinction makes sense semantically but it gets encoded opaquely in (61). This state of affairs is forced on us by the decision to insulate the semantics and the phonology from each other, allowing them to talk only via the syntax. A similar point can be made regarding the Basic F Rule which stipulates a one-sided relation between F-marking and accent. Why should some accents require F-markers? Why is the relationship one sided, that is, why don't F-markers require accents? From the standpoint of interpretation, the Rule asserts that some accents are incompatible with givenness. As Gussenhoven (1984), Pierrehumbert and Hirschberg (1990) and others contend, accents are meaningful. The incompatibility which lies behind the Basic F Rule should therefore just follow from the meaning of the accents in question (H*, L*H in questions and probably others) and the information status of the words they are attached to.

As we have lately argued, F markers have no significant syntactic properties. From the point of view of the grammar overall, they are a nuisance and do not shed light on the real question of what semantic information is relevant to phonology and what parts of the phonology see this information. Ultimately, they should be done away with.¹²

7. SUMMARY

We conclude by returning to the questions posed in the introduction:

- (5) a. What are the primitives of the theory of discourse appropriateness?
b. What are the units, syntactic or otherwise, to which appropriateness conditions apply?
c. What is the relation between a unit of discourse appropriateness and the locus of prominence?

d. What are the ingredients of intonational prominence?

Discourse appropriateness is calculated for units defined in terms of standard syntactic constituency and F-marking and it distinguishes constituents that are GIVEN from those that are not. A constituent that is GIVEN presupposes an antecedent with the same meaning, up to F-marked parts. F-marking is used parsimoniously and is constrained by discourse appropriateness and by the positioning of pitch accents, the only factor contributing to intonational prominence that is considered here. F-markers that must correspond to alternatives in the discourse must dominate an accent. Non-discourse related rules of syntax/phonology further regulate accent placement.

NOTES

This paper has benefitted from opportunities for presenting work at a conference on "Interfaces of Grammar: Theoretical and Computational Aspects" held at the University of Tübingen in 1996, and at Cornell, Hebrew University, the Rutgers Center for Cognitive Science, UCLA, UMass/Amherst, UPenn, UC Santa Cruz, University of Southern California and the Tel-Aviv Semantics Circle. I wish to thank Maria Bittner, Daniel Büring, Kai von Stechow, Jane Grimshaw, Inga Kohlhof, Bill Ladusaw, Alan Prince, Renate Raffelsiefen, Mats Rooth, Lisa Selkirk, Uli Sauerland, Nomi Shir, Joe Taglicht, Satoshi Tomioka, Hubert Truckenbrodt and Karina Wilkinson and the editors of this journal for their contribution to the research reported here. Comments by both anonymous reviewers led to substantial improvements in content and form. They are greatly appreciated. I am grateful to Hubert Truckenbrodt for his interest and encouragement.

¹There is a third rule which will be ignored here completely:

(i) F-marking of the antecedent of a trace left by NP- or *wh*-movement licenses the F-marking of the trace.

²As Selkirk noted, for this generalization to hold, F-marking must not project from just any kind of pitch accent. A casual reading of the following quote from the *Philobiblon* by Richard de Bury illustrates one type of exception:

In books I find the dead as if they were alive; in books I foresee things to come; in books warlike affairs are set forth; from books come forth the laws of peace. All things are corrupted and decay in time; Saturn ceases not to devour the children that he generates; all the glory of the world would be buried in oblivion, unless God had provided mortals with the remedy of books.

books is accented throughout, even in object position (cf. Nootboom & Kruyt 1987).

³The restriction to non-F-marked constituents is due, at least in part, to an assumption that $[[\alpha]_{Fn}]^{g,h}$ is the same type as $[[\alpha]]^g$. Discourse fragments such as *John laughed, no EVERYBODY laughed* or *No women objected, but JOHN objected* show that ultimately that

assumption will have to be lifted. See Schwarzschild(1998) for further details.

⁴ A constraint similar to this one was proposed in Schwarzschild(1993) based on the differences in acceptability observed in the following pairs:

(i) Whose farm did Mary pick strawberries at?

She picked strawberries at SANDY_F's farm.

#She picked STRAWBERRIES_F at SANDY'S_F farm.

(ii) Who appointed John?

a. JOHN_F appointed John.

b. #John [appointed_F JOHN_F]_F.

Rochemont(1986:65, fn66) makes a suggestion in this direction as well, though it would not account for (ii).

⁵Ede Zimmermann objects to this last claim noting that the use of the phrase *John's mother* guarantees that the existential closure of the interrogative entails that she, John's mother, bears the mother relation to John. Assuming that this really is an entailment and not just a presupposition, there are still two factors that prevent the interrogative from allowing the answer F-marked as in (42) to count as GIVEN. The first factor has to do with the possible values for R. Since R replaces a transitive verb, its range may be limited to transitive verb meanings. The second has to do with the observation that with the F-marking in (42), *John's mother* may act as its GIVENness antecedent as opposed to the interrogative it is being used to answer. These factors will be discussed in more detail in section 5 where it will be argued that the choice of F-marking is such as to rule out unintended GIVENness antecedents.

⁶A reviewer noted the following variant:

(i) {John drove Mary's red convertible. What did she drive?}

She drove her BLUE convertible.

which violates the GIVENness Constraint on the sentence level. Its analysis will have to await the revisions of section 6.

⁷The F-marking in this example is justified as follows. Neither *dissed* nor *Sue* has an antecedent in the discourse, hence both must be F-marked. Checking un-F-marked nodes, the VP satisfies the GIVENness Constraint, because *John cited Mary* entails $\exists x \exists X \exists Y [x \text{ X-ed } Y]$. The sentence satisfies the GIVENness Constraint, because *John_i cited Mary* entails $\exists X \exists Y [He_i \text{ X-ed } Y]$. Avoid F prohibits additional F markers.

This type of example illustrates why in section 2.2 we decided to index F-markers. In order for the VP and the sentence to satisfy the GIVENness Constraint, *h*, the function that assigns values to F-markers, will have to assign to F1 the meaning of *cited* and to F2 it will assign *Sue*. If F-markers were unindexed *h* couldn't assign them different values.

⁸ a **immediately dominates** b iff a dominates b, and every branching node c (c≠b) that dominates b also dominates a.

⁹The example that was problematic for Rochemont was Akmajian and Jackendoff(1970)'s {*John washed the car*} *I was afraid some ELSE would do it* . The problem was the verb is unaccented, not sister to an F-marked internal argument and yet not given. The syntactically unconstrained F-marking assumed here allows for:

i. [_{VP} afraid_F [someone ELSE_F]_F would do it]_F

¹⁰FOC might more properly be correlated with a stress level or a level of the unit of prosodic structure.

¹¹Note, the lack of accent on the object in {*John quoted the Bible. no,*} *he CONTRADICTED_F the Bible*, is often not counted as a case of deaccenting, but if HeadArg was ranked above AvoidF this is likely to go as well. This would depend on whether HeadArg was above FOC and what other costs were involved in placing an accent on both *contradict* and *Bible* versus leaving both unaccented.

¹²Schwarzschild(1998) is an attempt at spelling out the relationship between givenness/accent using rules that directly relate pragmatics and phonology.

REFERENCES

- Akmajian, A. and R. Jackendoff: 1970, "Coreferentiality and Stress," *Linguistic Inquiry* 1.124-6.
- Allerton, D.J.: 1978, "The Notion of 'Givenness' and its Relations to Presupposition and to Theme," *Lingua* 44.133-68.
- Bäuerle, R.: 1979, "Questions and Answers," in: R. Bäuerle, U. Egli and A. von Stechow (eds.) *Semantics from Different Points of View*, Berlin-Heidelberg-New York: Springer.
- Büring, D.: 1996, "On (De)Accenting," talk given at *Interfaces of Grammar* a conference funded by SFB 340, Stuttgart/Tübingen, held at Universität Tübingen, September 30 - October 3, 1996
- Cinque, G.: 1991, "A Null Theory of Phrase and Compound Stress," *Linguistic Inquiry* 24.2, 239-297
- Cresswell, M.J.: 1973, *Logics and Languages*, Methuen & Co. Ltd., London.
- Deemter, Kees van: 1994, "What's New? A Semantic Perspective on Sentence Accent," *Journal of Semantics* 11.1-2:1-31.
- Gussenhoven, C.: 1983, "Focus, mode and nucleus," *Journal of Linguistics* 19:377-417
- Gussenhoven, C. : 1984, *On the Grammar and Semantics of Sentence Accents*. Dordrecht: Foris Publications.
- Gussenhoven, C.: 1992, "Sentence accents and argument structure," in I.M. Roca (ed.) *Thematic Structure: Its Role in Grammar*, New York: Foris.
- Halliday, M.A.K. : 1967, "Notes on transitivity and theme in English (Part 2)," *Journal of Linguistics* 3:199-244.
- Jackendoff, R., 1972, *Semantic Interpretation in Generative Grammar*, M.I.T. Press, Cambridge.
- Jacobs, J.: 1991, "Focus Ambiguities," *Journal of Semantics* 8:1-36.
- Karttunen, L.: 1977, "The Syntax and Semantics of Questions," *Linguistics and Philosophy* 1:3-44.
- Kratzer, A.: 1991, "The Representation of Focus," in Arnim von Stechow and Dieter Wunderlich, (eds.) *Semantik/Semantics: An International Handbook of Contemporary Research*, 825-834, de Gruyter, Berlin.
- Krifka, M.: 1992, "A Framework for Focus-Sensitive Quantification," *Proceedings of the Second Conference on Semantics and Linguistics Theory*, (Ohio State Working Papers in Linguistics No. 40) David Dowty and Chris Barker (eds.), pages 215-236, Columbus, Ohio.
- Ladd, D. R.: 1980, *The Structure of Intonational Meaning*, Indiana University Press, Bloomington.
- Ladd, D. R.: 1996, *Intonational Phonology* Cambridge University Studies in Linguistics 79, Cambridge University Press.
- Nooteboom, S. G. and J. G. Kruyt (1987) "Accents, Focus Distribution, and the Perceived Distribution of Given and New Information: An Experiment," *Journal of the Acoustical Society of America*, vol. 82 no. 5
- Pierrehumbert, J.: 1993, "Alignment and Prosodic Heads," in Andreas Kathol and Michaela Bernstein (eds.) *Proceedings of the Tenth Eastern States Conference on Linguistics*, distributed by Department of Linguistics, Cornell University.
- Prince, E.F. : 1981, "Toward a taxonomy of given/new information," In Cole, P., (ed.) *Radical Pragmatics*. NY: Academic Press. Pp. 223-55.
- Prince A. and P. Smolensky: 1993, *Optimality Theory: Constraint Interaction in Generative*

- Grammar. RuCCS Technical Report #2. Rutgers University Center for Cognitive Science, Piscataway, NJ.
- Rochemont, M.: 1986, *Focus in Generative Grammar*, Benjamins, Amsterdam.
- Rochemont, M.: 1997, "Phonological Focus and Structural Focus," in Peter Culicover and Louise McNally (eds.) *The Limits of Syntax*, Syntax and Semantics Volume 29
- Rooth, M. : 1985, "Association with Focus," Ph.D. dissertation, University of Massachusetts, Amherst, Distributed by GLSA, Amherst.
- Rooth, M.: 1992, "A Theory of Focus Interpretation," *Natural Language Semantics* 1:75-116
- Rooth, M.: 1995, "Focus," in Lappin, S. (ed.), *The Handbook of Contemporary Semantic Theory*, Blackwell Publishers, London.
- Schmerling, S.F. : 1976, *Aspects of English Sentence Stress*, Austin: University of Texas Press.
- Schwarzschild, R. : 1993, "The Contrastiveness of Associated Foci," Talk presented at Workshop on Focus and Quantification, Fifth European Summer School in Logic, Language and Information, Universidade de Lisboa, Portugal.
- Schwarzschild, R.: 1998, Interpreting Accent, Rutgers ms. <http://www.rci.rutgers.edu/~tapuz/>.
- Selkirk, E. O.: 1984 *Phonology and Syntax: The Relation between Sound and Structure*, MIT Press, Cambridge
- Selkirk, E. O.: 1996, "Sentence Prosody: Intonation, Stress and Phrasing," in *The Handbook of Phonological Theory*, John A. Goldsmith (ed.) Basil Blackwell: London.
- Taglicht, J.: 1982, "Intonation and the Assessment of Information," *Journal of Linguistics* 18.2
- Taglicht, J.: 1984, *Message and Emphasis*, Longman, London and New York.
- Terken, J. and Hirschberg, J: 1994, "Deaccentuation of Words Representing 'Given' Information: Effects of Persistence of Grammatical Function and Surface Position" *Language and Speech* vol. 37 no. 2
- Truckenbrodt, H.: 1995, *Phonological Phrases: Their Relation to Syntax, Focus and Prominence* Doctoral dissertation, MIT.
- Truckenbrodt, H.: 1998, "Phrasal Stress," Rutgers ms.
- Vallduví E. and E. Engdahl: 1996, "The Linguistic Realization of Information Packaging," *Linguistics* 34:459-516
- von Stechow, K.: 1994, "Restrictions on Quantifier Domains," Ph.D Dissertation, University of Massachusetts, Amherst.
- Williams, E.: 1980, "Remarks on Stress and Anaphora," *Journal of Linguistic Research* 1.3:1-16.
- Zucchi, A.: 1995, "The Ingredients of Definiteness and the Definiteness Effect," *Natural Language Semantics*, Vol 3, No. 1, pages 33-78