

Circuit Design & EC Domain Publications

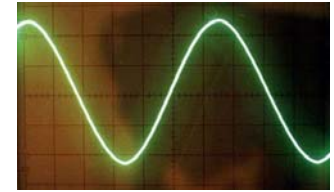

Evolutionary Computation:

- Aggarwal, “**Evolving Sinusoidal Oscillators Using Genetic Algorithms**”, in Proc., The 2003 NASA/DoD Conference on Evolvable Hardware, Chicago, USA, pp. 67-76, 2003

Analog Circuit Design Journals:

- Aggarwal, “**Novel Canonic Current Mode DDCC based SRCO synthesized using Genetic Algorithms**”, in Analog Integrated Circuits and Signal Processing (Springer), Vol: 40, 83–85, 2004
- Kilinc, Jain, Aggarwal, Cam, “**Catalogue of Variable Frequency and Single-Resistance-Controlled Oscillators Employing A Single Differential Difference Complementary Current Conveyor**”, To appear in Frequenz: Journal of RF-Engineering and Telecommunications (Germany), July-August, 2006
- Aggarwal, Kilinc, Cam, “**Minimum component SRCO and VFO using a single DVCCC,**” Accepted, Analog Integrated Circuits and Signal Processing (Springer), 2006

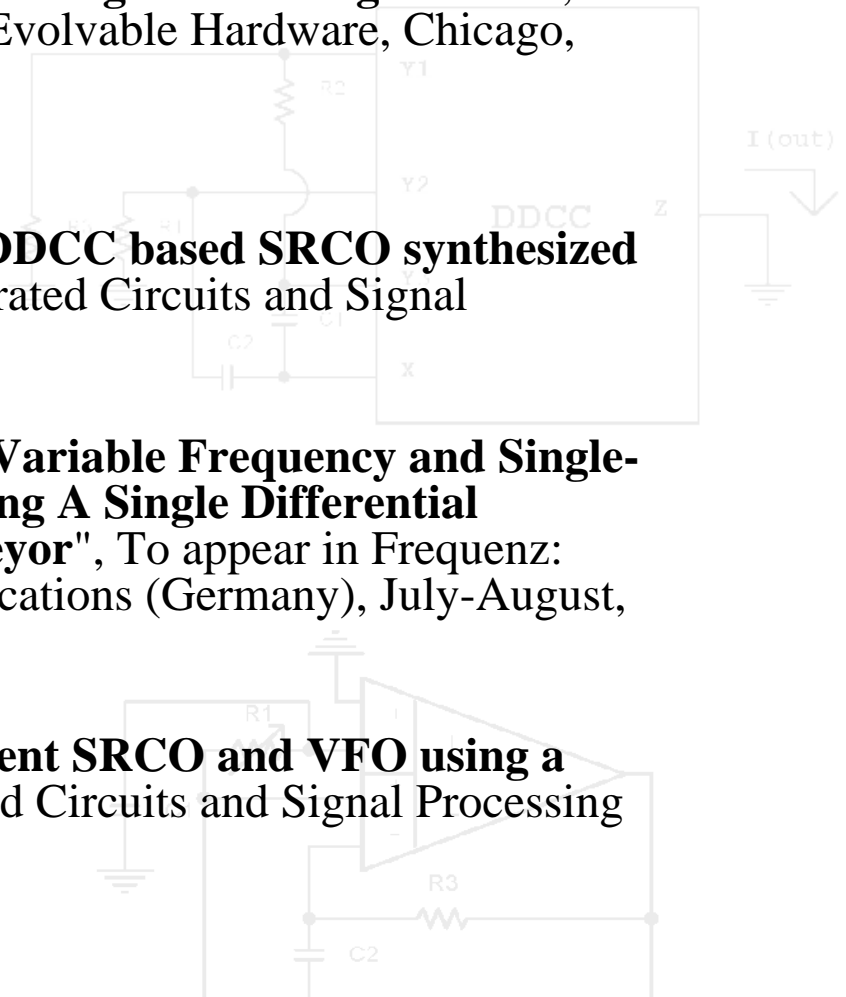

Why Human-Competitive?

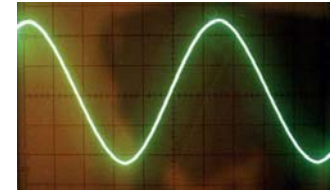

- Results equal and improve over current human-designed oscillators.
- Trustworthy circuits
 - Not only of intellectual value, but of practical use.
- Discovery of new design principles.
- Accepted in analog design journals as a result in their own.
- Successful design automation in a unrelenting and needy field.

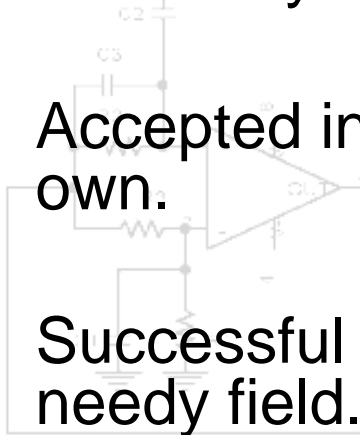

Sine-wave oscillators

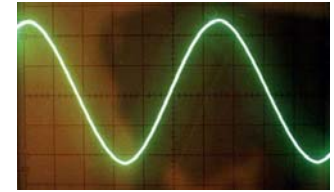

- Produce sine-wave as output for no input (lossless circuit) or DC input.

- Sine-wave oscillators have various applications:

- Communication systems,
- Control and measurement,
- Signal processing, etc.

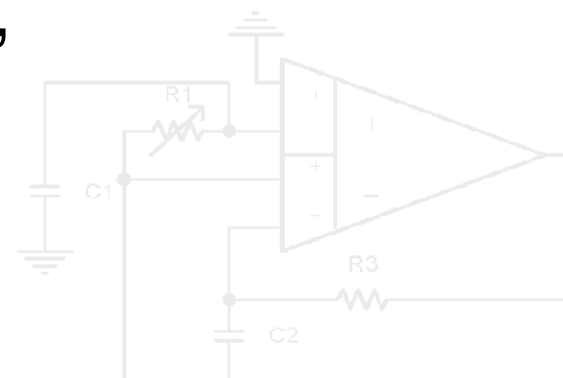
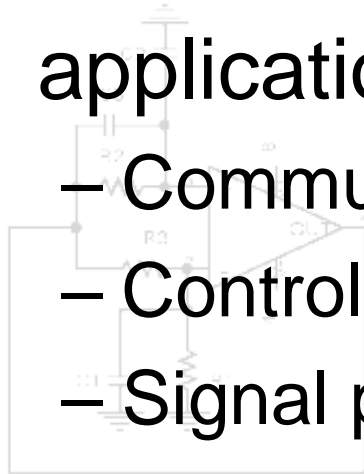

Desired properties in an oscillator

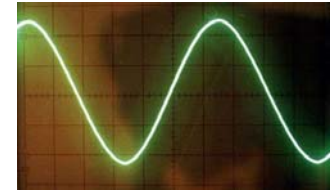

- Need for **trustworthy** circuit. Fulfil two conditions:
 1. Can be analyzed and is human Interpretable.
 2. Works on SPICE with high-fidelity models OR actual implementation.

- Control of frequency by a single resistance

- For low power and area.

- Use of single active element
- Use of least number of resistors and capacitors

- Other topological features

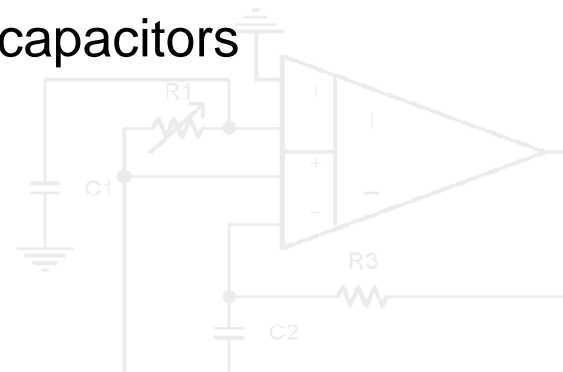
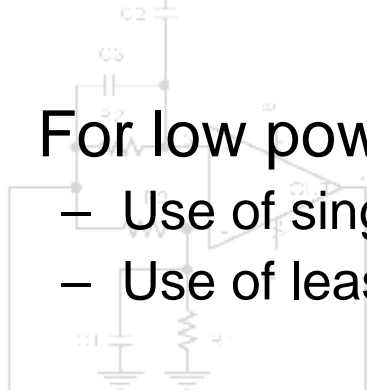
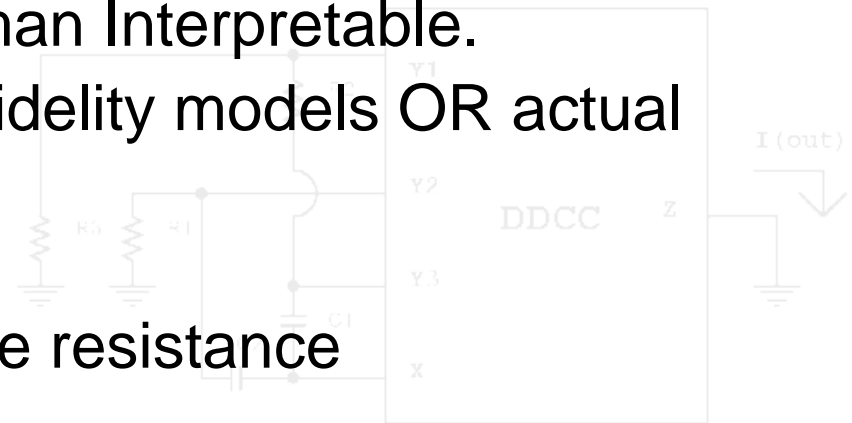

Genetic Algorithm to invent oscillators

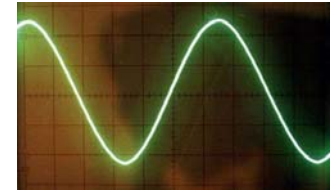

Sine-wave oscillator design using **any** linear active element(s)

Fitness Evaluation

- **Use of symbolic analysis** (NO SPICE invoked)
Parse symbolic transfer function to assign fitness.
- Use of first-order model for active-element.

Advantages of symbolic analysis based fitness evaluation

- Trustworthy circuits:
 - Guarantees human interpretable circuits: Humans do symbolic analysis!
 - Most circuits work on SPICE/actual implementation and if they don't, one can explain why.
- Ability to search in otherwise spiked search-space

Comparison to conventional approaches

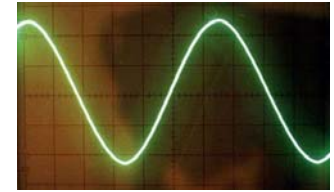

- Human designed:
 - Adhoc, intuition, analysis.
 - Use of specific design principle
- Exhaustive approaches:
 - Mathematically rigorous. Assumedly infeasible with complex active element, size/topological constraints.

- **Genetic Algorithm:** Push button approach to oscillator synthesis
Automatic, No human designer,
No mathematics,
Scaleable approach that considers full extent of search space,
Can it find innovative (and reusable) design principles?

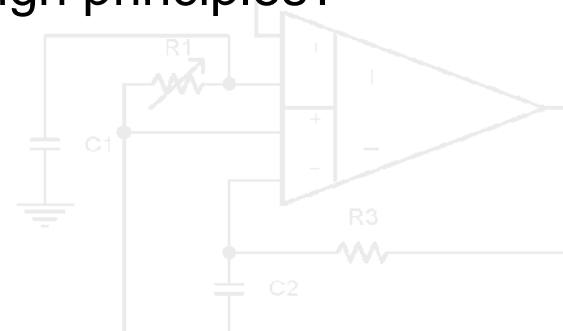
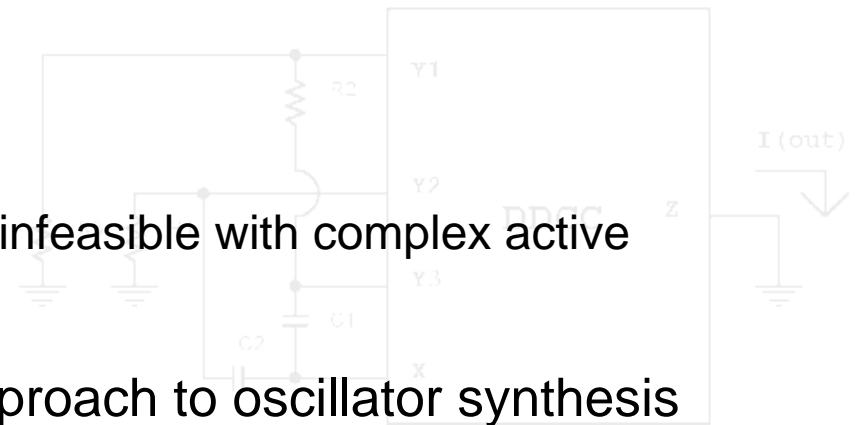
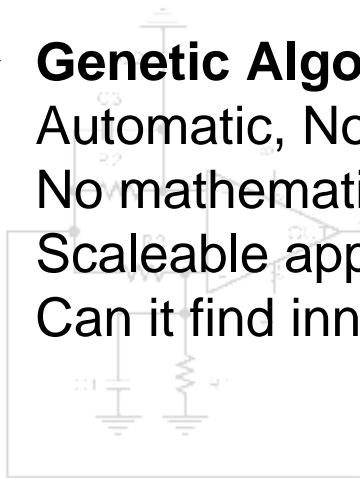

Oscillator Research

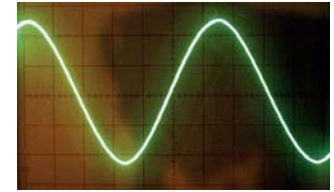

CURRENT STATE

- 70-80's: Opamp based oscillator with 5 R and 2 C
- 90's and 00: 8 CFOA based oscillators using 3R and 2C.

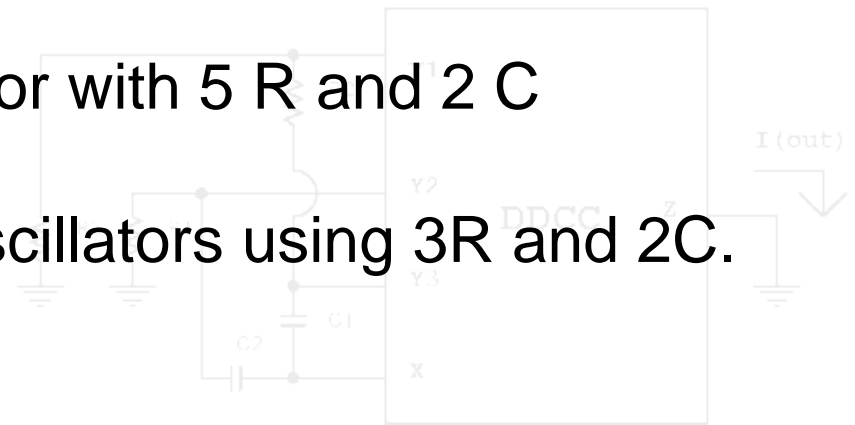

RESEARCH IMPETUS

- Oscillators exploiting different active elements to better the state-of-art.
- New requirement for explicit current mode output.

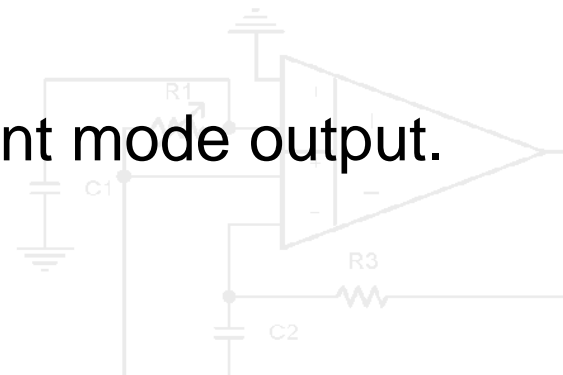
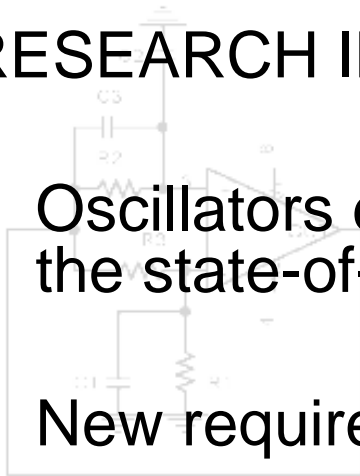

Genetic Algorithm invents topologies

2003: Opamp based oscillators

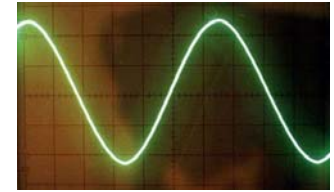

- Reinvents all single frequency oscillators published by Bhattacharya, et. al. 1984 as published in an analog design journal.
- Value of result:
 - Human-equivalent designs
 - GA searches the topological space well.
 - Human interpretable and SPICE validated

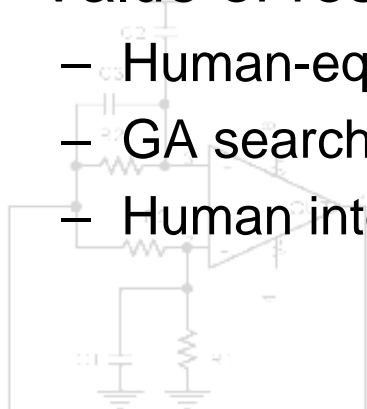

Aggarwal, “**Evolving Sinusoidal Oscillators Using Genetic Algorithms**”, in Proc., *The 2003 NASA/DoD Conference on Evolvable Hardware, Chicago, USA, 2003, pp. 67-76.*

Genetic Algorithm invents topologies

2004: DDCC based oscillator

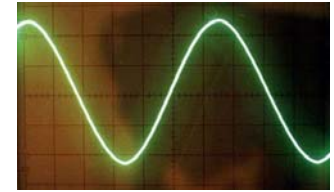

- Combined all desired properties
- First oscillator using Differential Difference Current Conveyor

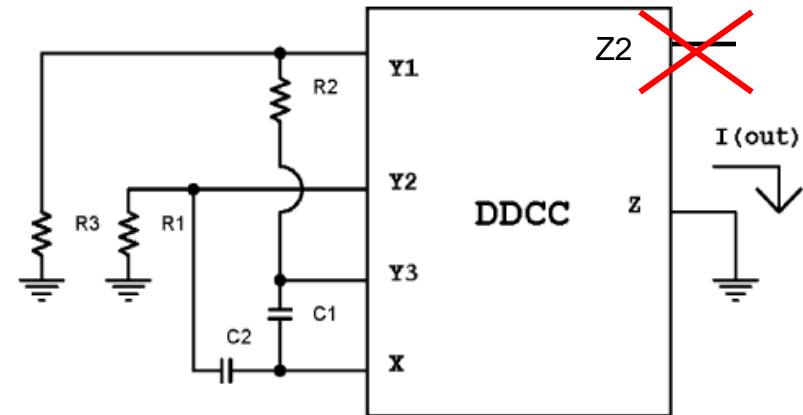

- Network Theory result: Only voltage-mode topology using 3R and 2C

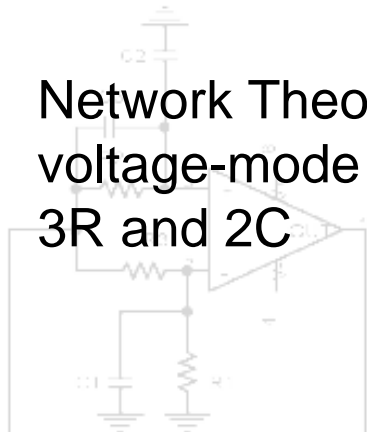

Value of result

- Novel design
- Discovery of new design principle
- Practical Value: Lower power and area
- Human interpretable and SPICE validated

V. Aggarwal, "Novel Canonic Current Mode DDCC based SRCO synthesized using Genetic Algorithms", in *Analog Integrated Circuits and Signal Processing*, Vol: 40, 83–85, 2004

Genetic Algorithm invents topologies

2006-a: Catalogue of DDCCC based oscillators

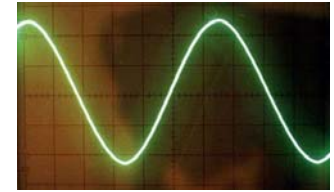

Family of 14 oscillators

- Combined all desired properties
- Largest catalogue of oscillators using single active element.

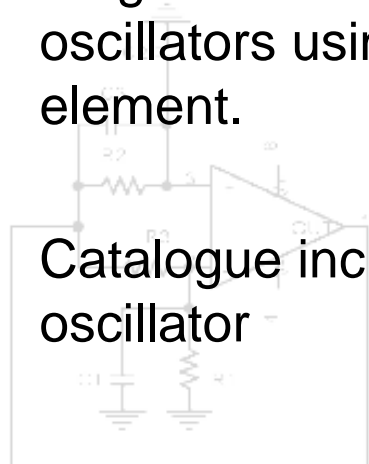

- Catalogue includes a unique oscillator

Value of result:

- Suite of Designs
- Practical Value: 14 new state-of-art oscillators for the analog designer to choose from.
- Human interpretable and SPICE validated
(7 stable, 7 unstable with a specific DDCCC implementation).

Kilinc, Jain, Aggarwal, Cam, "Catalogue of Variable Frequency and Single-Resistance-Controlled Oscillators Employing A Single Differential Difference Complementary Current Conveyor", to appear in Frequenz: Journal of RF-Engineering and Telecommunications (Germany), July-August, 2006

Genetic Algorithm invents topologies

2006-a: Catalogue of DDCCC based oscillators

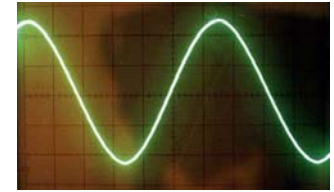

- Combines all desirable properties
- Uses only **2 resistors and 2 capacitors.**
- Sacrifices independent control of condition of oscillation (not important)

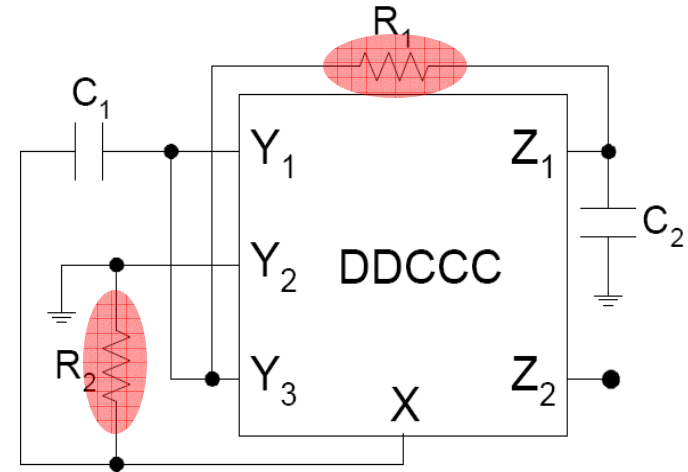
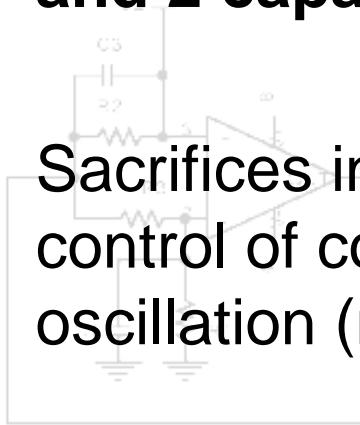

Value of result

- Design beyond expectation
- A new design principle
- **Improvement** over the state-of-art: Lower in power and area.
- Human interpretable and SPICE validated (Unstable with DDCCC implementation)

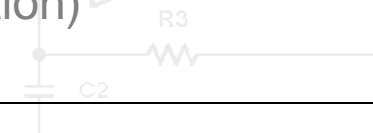

Genetic Algorithm invents topologies

2006-b: Grounded Capacitor oscillators

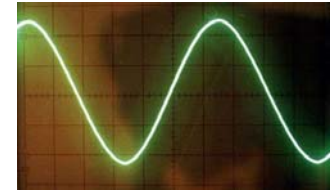

- Oscillator using DVCCC
- Combined all properties
- **Uses only Grounded capacitors**

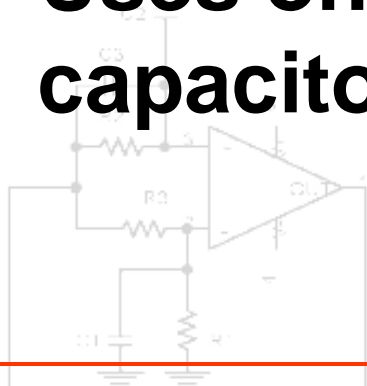

Aggarwal, Kilinc, Cam, “**Minimum component SRCO and VFO using a single DVCCC,**” Accepted, Analog Integrated Circuits and Signal Processing (Springer), 2006

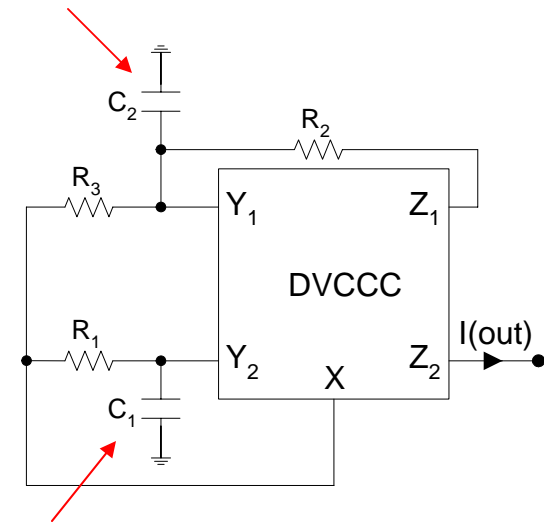

Value of result

- Usefulness of searching the whole search space.
 - Not discovered in oscillator synthesis strategy of Gupta, Senani, 2005.
- **Addition** to state-of-art
- Human Interpretable and SPICE validated.

Genetic Algorithm invents topologies

2006-c: Grounded Capacitor oscillators

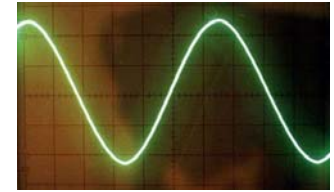

Oscillator using DVCCC

- Combined all properties
- **Uses only Grounded capacitors**
- **Only 2 resistors!**

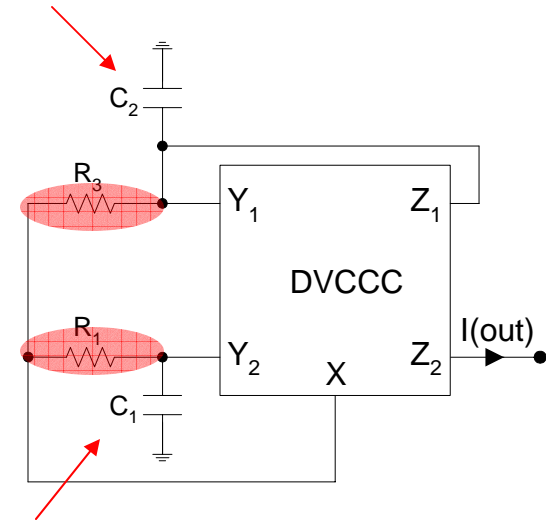

Value of result:

- **Completely dominates state-of-art** : Lower power area and gnded capacitors
- Use of a 'New design principle'.
- Human Interpretable and SPICE validated

Aggarwal, Kilinc, Cam, "Minimum component SRCO and VFO using a single DVCCC," Accepted, Analog Integrated Circuits and Signal Processing (Springer), 2006

Genetic Algorithm invents topologies

Grounded Capacitor oscillators

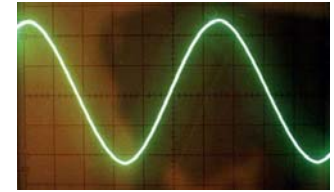

- Differential Difference Amplifier based **voltage mode oscillator**
- Combined all properties
- Only voltage mode oscillator with grounded capacitors
- Discrete Component implementation also!

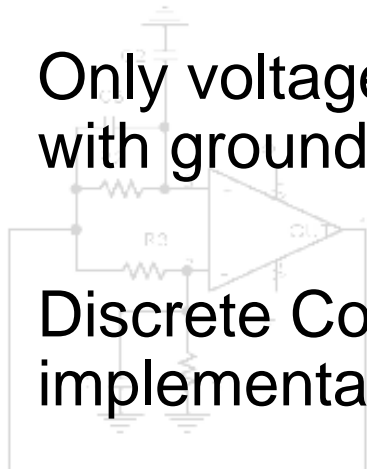

New Result!
To be published soon 😊

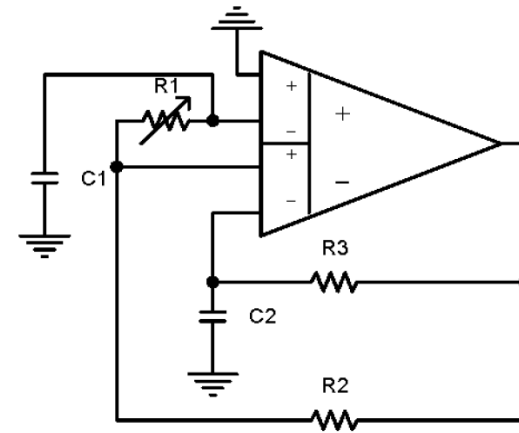

Value of result

- **Dominates the state of art.**
- Practical Use: Both discrete and silicon implementation, gnded capacitors
- Human Interpretable, SPICE validated, Actually implemented

Genetic Algorithm invents topologies

Grounded Capacitor oscillators

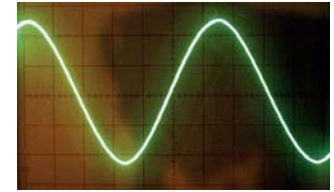

Only oscillator of its kind

- Voltage mode grounded capacitor VFO
- Uses minimum passive elements, 3R and 2C
- Uses an already existing widely used active element
- Can be implemented using a discrete IC.

Cam, Toker, Cicekoglu and Kuntman's oscillator using FTFN (Fig. 2, Oscillator 1 of [14])	2000	×	5	both	√	×	√	×	×
Lee and Wang's oscillator using FTFN ⁺ (Fig. 1 of [15])	2001	×	3	both	√	×	×	×	×
Bhaskar's oscillator using FTFN ⁺ (Fig. 1 of [16])	2002	×	4	both	√	√	×	×	×
Ozcan, Toker, Acar and Kuntman's oscillators using CDBA (Oscillators 1-4, 6 in Table 1 of [22])	2000	×	3	FO	√	×	×	√	×
Cam's oscillator using OTRA (Fig. 1 of [17])	2002	×	3	FO	√	×	×	√	×
Gupta and Senani's oscillator using DVCCC (Fig. 1 of [23])	2000	×	3	both	√	√	√	×	×
Gunes and Toker's oscillators using DVCFA (Oscillators A1-B3, A1-B4, A2-B3, A2-B4 in Table 3a of [24])	2002	×	3	both	√	√	×	√	×
Chang, Al-Hashimi, Chen, Tu and Wan oscillators using FDCCII (Figs. 1 and 2 of [26])	2002	×	3	both	√	√	√	×	×
New SRCOs using DDCCFA	new	×	3	both	√	√	√	√	√

'Canonic' refers to the circuits using only two capacitors

** explicit CM with ideally ∞ output impedance and explicit VM with ideally zero output impedance

Yr: year of publication; CA: commercial availability of the ABB; N: number of resistors used; SRC: SRC of CO/FO; S: simple CO (no more than one condition); E: employment of two GCs

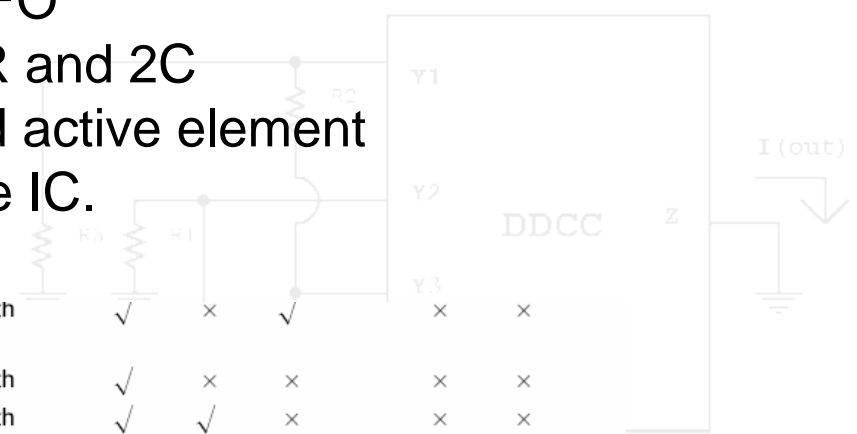

Genetic Algorithm invents topologies

Grounded Capacitor oscillators

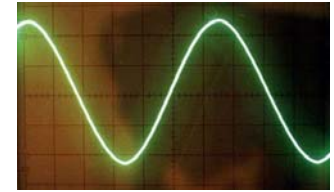

- Of course, it works using actual components!
- Used AD830

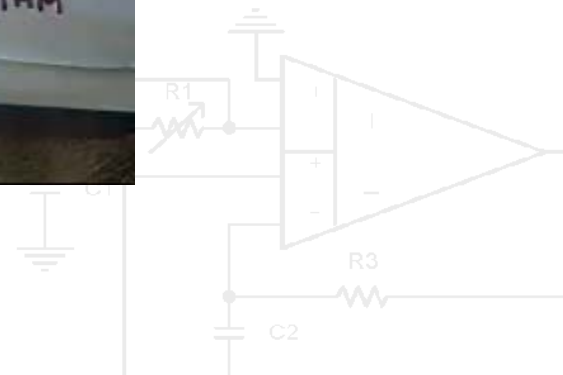
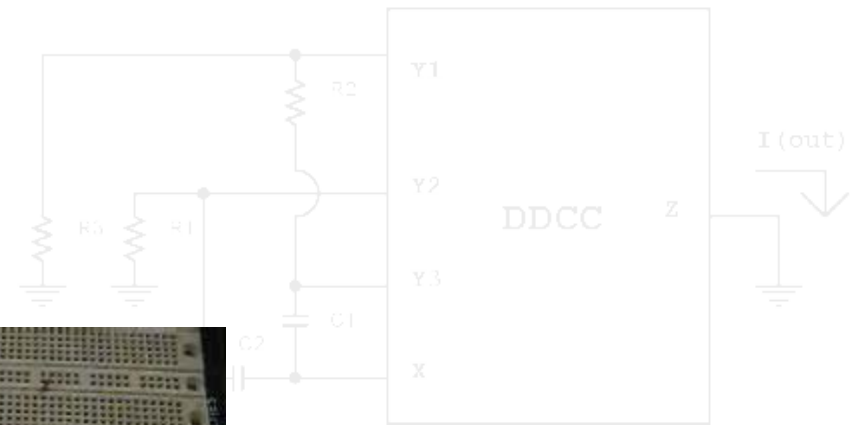
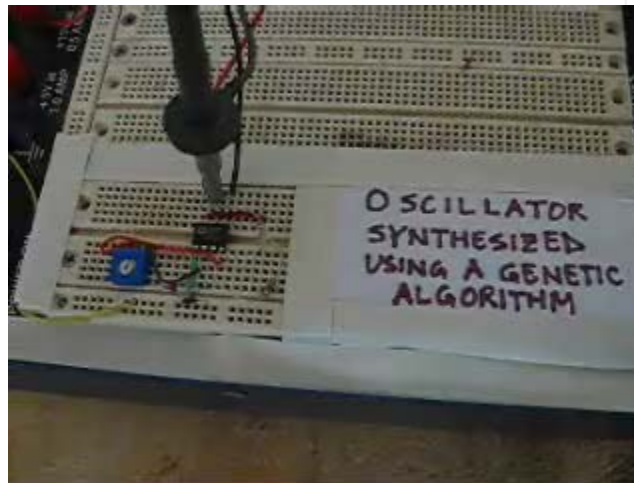
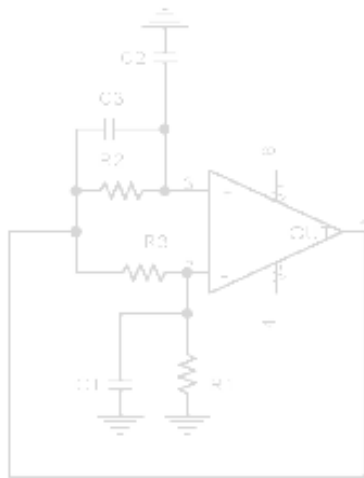

Summary

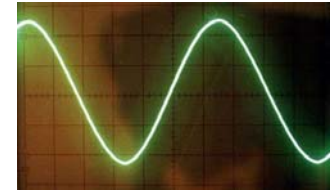

- Opamp based oscillators
 - **Rediscovery** of human designed oscillators
- DDCC based oscillator
 - Uses one terminal less, **Lower area and power**
- DDCCC based catalogue of 14 oscillators
 - New useful topologies, New design principle
- DVCCC based 2R, 2C oscillator
 - The **only oscillator of its kind**, Improvement to state-of-art.
- DDA based grounded capacitor oscillator
 - The **only oscillator of its kind**, Improvement to state of art.

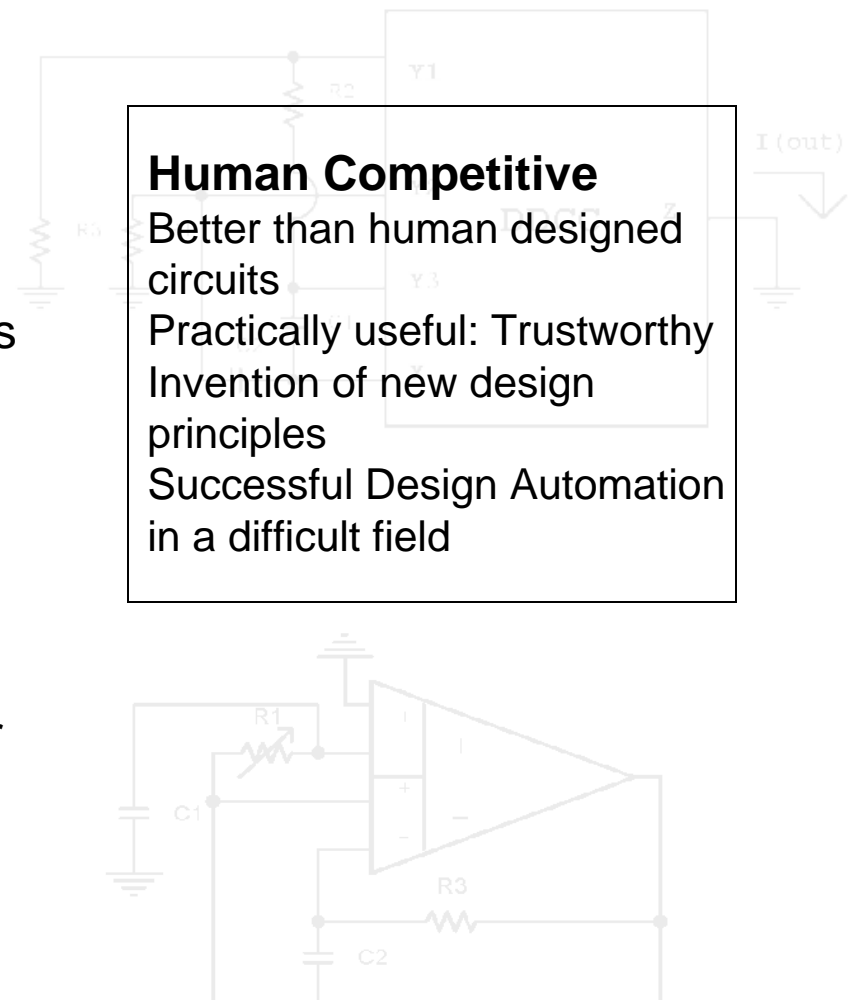

Acknowledgments

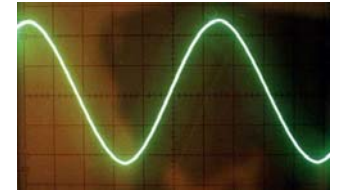

Special thanks to:

- Prof. Raj Senani
- Dr. Paul Layzell
- Dr. Una-May O'Reilly
- Dr. Eduard Sackinger
- Dr. Charles Kemp
- Prof. James Grimbleby

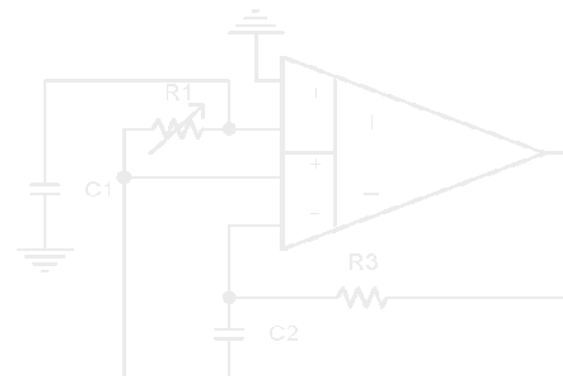
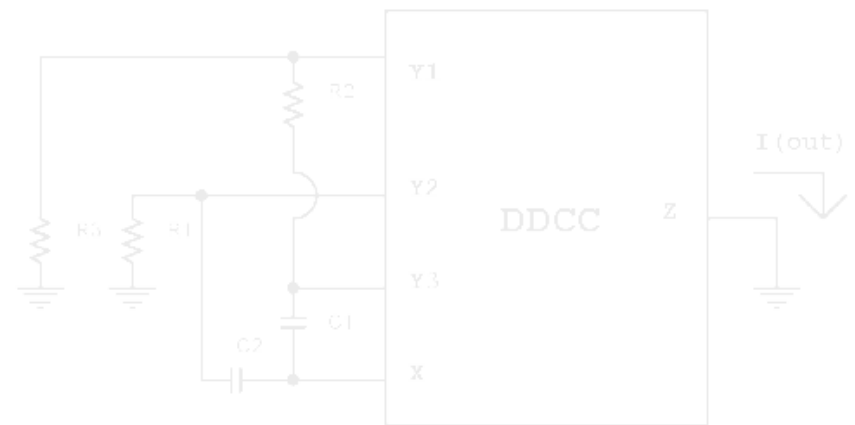
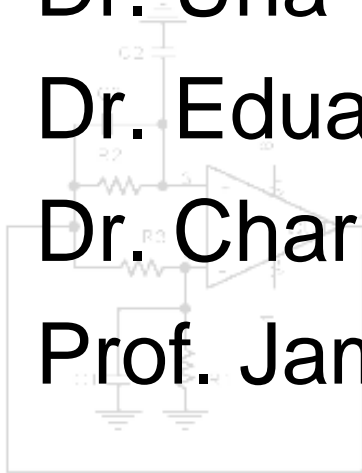

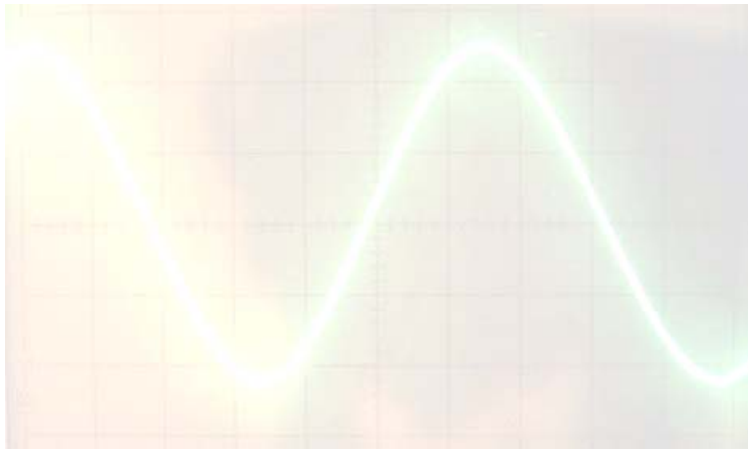

Thank you!

Suggestions, comments

varun_ag@mit.edu

