

# Analysis of the Joint Spectral Radius via Lyapunov Functions on Path-Complete Graphs

Amir Ali Ahmadi (a\_a\_a@mit.edu)  
Raphaël M. Jungers (raphael.jungers@uclouvain.be)  
Pablo A. Parrilo (parrilo@mit.edu)  
Mardavij Roozbehani (mardavij@mit.edu)

Laboratory for Information and Decision Systems  
Massachusetts Institute of Technology  
Cambridge, MA, USA

## ABSTRACT

We study the problem of approximating the joint spectral radius (JSR) of a finite set of matrices. Our approach is based on the analysis of the underlying switched linear system via inequalities imposed between multiple Lyapunov functions associated to a labeled directed graph. Inspired by concepts in automata theory and symbolic dynamics, we define a class of graphs called path-complete graphs, and show that any such graph gives rise to a method for proving stability of the switched system. This enables us to derive several asymptotically tight hierarchies of semidefinite programming relaxations that unify and generalize many existing techniques such as common quadratic, common sum of squares, maximum/minimum-of-quadratics Lyapunov functions. We characterize all path-complete graphs consisting of two nodes on an alphabet of two matrices and compare their performance. For the general case of any set of  $n \times n$  matrices we propose semidefinite programs of modest size that approximate the JSR within a multiplicative factor of  $1/\sqrt[k]{n}$  of the true value. We establish a notion of duality among path-complete graphs and a constructive converse Lyapunov theorem for maximum/minimum-of-quadratics Lyapunov functions.

## Categories and Subject Descriptors

I.1.2 [Symbolic and algebraic manipulations]: Algorithms—*Analysis of algorithms*

## General Terms

Theory, algorithms

## Keywords

Joint spectral radius, Lyapunov methods, finite automata, semidefinite programming, stability of switched systems

Permission to make digital or hard copies of all or part of this work for personal or classroom use is granted without fee provided that copies are not made or distributed for profit or commercial advantage and that copies bear this notice and the full citation on the first page. To copy otherwise, to republish, to post on servers or to redistribute to lists, requires prior specific permission and/or a fee.

HSCC'11, April 12–14, 2011, Chicago, Illinois, USA.

Copyright 2011 ACM 978-1-4503-0629-4/11/04 ...\$10.00.

## 1. INTRODUCTION

Given a finite set of matrices  $\mathcal{A} := \{A_1, \dots, A_m\}$ , their *joint spectral radius*  $\rho(\mathcal{A})$  is defined as

$$\rho(\mathcal{A}) = \lim_{k \rightarrow \infty} \max_{\sigma \in \{1, \dots, m\}^k} \|A_{\sigma_k} \dots A_{\sigma_2} A_{\sigma_1}\|^{1/k}, \quad (1)$$

where the quantity  $\rho(\mathcal{A})$  is independent of the norm used in (1). The joint spectral radius (JSR) is a natural generalization of the spectral radius of a single square matrix and it characterizes the maximal growth rate that can be obtained by taking products, of arbitrary length, of all possible permutations of  $A_1, \dots, A_m$ . This concept was introduced by Rota and Strang [26] in the early 60s and has since been the subject of extensive research within the engineering and the mathematics communities alike. Aside from a wealth of fascinating mathematical questions that arise from the JSR, the notion emerges in many areas of application such as stability of switched linear dynamical systems, computation of the capacity of codes, continuity of wavelet functions, convergence of consensus algorithms, trackability of graphs, and many others. See [16] and references therein for a recent survey of the theory and applications of the JSR.

Motivated by the abundance of applications, there has been much work on efficient computation of the joint spectral radius; see e.g. [1], [5], [4], [21], and references therein. Unfortunately, the negative results in the literature certainly restrict the horizon of possibilities. In [6], Blondel and Tsitsiklis prove that even when the set  $\mathcal{A}$  consists of only two matrices, the question of testing whether  $\rho(\mathcal{A}) \leq 1$  is undecidable. They also show that unless P=NP, one cannot compute an approximation  $\hat{\rho}$  of  $\rho$  that satisfies  $|\hat{\rho} - \rho| \leq \epsilon\rho$ , in a number of steps polynomial in the size of  $\mathcal{A}$  and  $\epsilon$  [27]. It is easy to show that the spectral radius of any finite product of length  $k$  raised to the power of  $1/k$  gives a lower bound on  $\rho$  [16]. Our focus, however, will be on computing good upper bounds for  $\rho$ , which requires more elaborate techniques.

There is an attractive connection between the joint spectral radius and the stability properties of an arbitrary switched linear system; i.e., dynamical systems of the form

$$x_{k+1} = A_{\sigma(k)} x_k, \quad (2)$$

where  $\sigma : \mathbb{Z} \rightarrow \{1, \dots, m\}$  is a map from the set of integers to the set of indices. It is well-known that  $\rho < 1$  if and only if system (2) is *absolutely asymptotically stable* (AAS), that is, (globally) asymptotically stable for all switching sequences. Moreover, it is known [18] that absolute asymptotic stability

of (2) is equivalent to absolute asymptotic stability of the linear difference inclusion

$$x_{k+1} \in \text{co}\mathcal{A} x_k, \quad (3)$$

where  $\text{co}\mathcal{A}$  here denotes the convex hull of the set  $\mathcal{A}$ . Therefore, any method for obtaining upper bounds on the joint spectral radius provides sufficient conditions for stability of systems of type (2) or (3). Conversely, if we can prove absolute asymptotic stability of (2) or (3) for the set  $\mathcal{A}_\gamma := \{\gamma A_1, \dots, \gamma A_m\}$  for some positive scalar  $\gamma$ , then we get an upper bound of  $\frac{1}{\gamma}$  on  $\rho(\mathcal{A})$ . (This follows from the scaling property of the JSR:  $\rho(\mathcal{A}_\gamma) = \gamma\rho(\mathcal{A})$ .) One advantage of working with the notion of the joint spectral radius is that it gives a way of rigorously quantifying the performance guarantee of different techniques for stability analysis of systems (2) or (3).

Perhaps the most well-established technique for proving stability of switched systems is the use of a *common (or simultaneous) Lyapunov function*. The idea here is that if there is a continuous, positive, and homogeneous (Lyapunov) function  $V(x) : \mathbb{R}^n \rightarrow \mathbb{R}$  that for some  $\gamma > 1$  satisfies

$$V(\gamma A_i x) \leq V(x) \quad \forall i = 1, \dots, m, \quad \forall x \in \mathbb{R}^n, \quad (4)$$

(i.e.,  $V(x)$  decreases no matter which matrix is applied), then the system in (2) (or in (3)) is AAS. Conversely, it is known that if the system is AAS, then there exists a *convex* common Lyapunov function (in fact a norm); see e.g. [16, p. 24]. However, this function is not in general finitely constructable. A popular approach has been to try to approximate this function by a class of functions that we can efficiently search for using semidefinite programming. Semidefinite programs (SDPs) can be solved with arbitrary accuracy in polynomial time and lead to efficient computational methods for approximation of the JSR. As an example, if we take the Lyapunov function to be quadratic (i.e.,  $V(x) = x^T P x$ ), then the search for such a Lyapunov function can be formulated as the following SDP:

$$\begin{aligned} P &> 0 \\ \gamma^2 A_i^T P A_i &\leq P \quad \forall i = 1, \dots, m. \end{aligned} \quad (5)$$

The quality of performance of common quadratic (CQ) Lyapunov functions is a well-studied topic. In particular, it is known [5] that the estimate  $\hat{\rho}_{CQ}$  obtained by this method<sup>1</sup> satisfies

$$\frac{1}{\sqrt{n}} \hat{\rho}_{CQ}(\mathcal{A}) \leq \rho(\mathcal{A}) \leq \hat{\rho}_{CQ}(\mathcal{A}), \quad (6)$$

where  $n$  is the dimension of the matrices. This bound is a direct consequence of John's ellipsoid theorem and is known to be tight [3].

In [21], the use of sum of squares (SOS) polynomial Lyapunov functions of degree  $2d$  was proposed as a common Lyapunov function for the switched system in (2). The search for such a Lyapunov function can again be formulated as a semidefinite program. This method does considerably better than a common quadratic Lyapunov function in practice and its estimate  $\hat{\rho}_{SOS,2d}$  satisfies the bound

$$\frac{1}{2^{d/\eta}} \hat{\rho}_{SOS,2d}(\mathcal{A}) \leq \rho(\mathcal{A}) \leq \hat{\rho}_{SOS,2d}(\mathcal{A}), \quad (7)$$

<sup>1</sup>The estimate  $\hat{\rho}_{CQ}$  is the reciprocal of the largest  $\gamma$  that satisfies (5) and can be found by bisection.

where  $\eta = \min\{m, \binom{n+d-1}{d}\}$ . Furthermore, as the degree  $2d$  goes to infinity, the estimate  $\hat{\rho}_{SOS,2d}$  converges to the true value of  $\rho$  [21]. The semidefinite programming based methods for approximation of the JSR have been recently generalized and put in the framework of conic programming [22].

## 1.1 Contributions and organization

It is natural to ask whether one can develop better approximation schemes for the joint spectral radius by using multiple Lyapunov functions as opposed to requiring simultaneous contractibility of a single Lyapunov function with respect to all the matrices. More concretely, our goal is to understand how we can write inequalities among, say,  $k$  different Lyapunov functions  $V_1(x), \dots, V_k(x)$  that imply absolute asymptotic stability of (2) and can be checked via semidefinite programming.

The general idea of using several Lyapunov functions for analysis of switched systems is a very natural one and has already appeared in the literature (although to our knowledge not in the context of the approximation of the JSR); see e.g. [15], [7], [13], [12], [10]. Perhaps one of the earliest references is the work on “piecewise quadratic Lyapunov functions” in [15]. However, this work is in the different framework of constrained switching, where the dynamics switches depending on which region of the space the trajectory is traversing (as opposed to arbitrary switching). In this setting, there is a natural way of using several Lyapunov functions: assign one Lyapunov function per region and “glue them together”. Closer to our setting, there is a body of work in the literature that gives sufficient conditions for existence of piecewise Lyapunov functions of the type  $\max\{x^T P_1 x, \dots, x^T P_k x\}$ ,  $\min\{x^T P_1 x, \dots, x^T P_k x\}$ , and  $\text{conv}\{x^T P_1 x, \dots, x^T P_k x\}$ , i.e. the pointwise maximum, the pointwise minimum, and the convex envelope of a set of quadratic functions [13], [12], [10], [14]. These works are mostly done in continuous time for analysis of linear differential inclusions, but they have obvious discrete time counterparts. The main drawback of these methods is that in their greatest generality, they involve solving bilinear matrix inequalities, which are non-convex and in general NP-hard. One therefore has to turn to heuristics, which have no performance guarantees and their computation time quickly becomes prohibitive when the dimension of the system increases. Moreover, all of these methods solely provide sufficient conditions for stability with no performance guarantees.

There are several unanswered questions that in our view deserve a more thorough study: (i) With a focus on conditions that are amenable to convex optimization, what are the different ways to write a set of inequalities among  $k$  Lyapunov functions that imply absolute asymptotic stability of (2)? Can we give a unifying framework that includes the previously proposed Lyapunov functions and perhaps also introduces new ones? (ii) Among the different sets of inequalities that imply stability, can we identify some that are less conservative than some other? (iii) The available methods on piecewise Lyapunov functions solely provide sufficient conditions for stability with no guarantee on their performance. Can we give converse theorems that guarantee the existence of a feasible solution to our search for a given accuracy?

In this work, we provide the foundation to answer these questions. More concretely, our contributions can be summarized as follows. We propose a unifying framework based

on a representation of Lyapunov inequalities with labeled graphs and making some connections with basic concepts in automata theory. This is done in Section 2, where we define the notion of a path-complete graph (Definition 2.2) and prove that any such graph provides an approximation scheme for the JSR (Theorem 2.4). In this section, we also show that many of the previously proposed methods come from particular classes of path-complete graphs (e.g., Corollary 2.5 and Corollary 2.6). In Section 3, we characterize all the path-complete graphs with two nodes for the analysis of the JSR of two matrices. We completely determine how the approximations obtained from these graphs compare. In Section 4, we study in more depth the approximation properties of a particular class of path-complete graphs that seem to perform very well in practice. We prove in Section 4.1 that certain path-complete graphs that are in some sense dual to each other always give the same bound on the JSR (Theorem 4.1). We present a numerical example in Section 4.2. Section 5 includes approximation guarantees for a subclass of our methods, and in particular a converse theorem for the method of max-of-quadratics Lyapunov functions (Theorem 5.1). Finally, our conclusions and some future directions are discussed in Section 6.

## 2. PATH-COMPLETE GRAPHS AND THE JOINT SPECTRAL RADIUS

In what follows, we will think of the set of matrices  $\mathcal{A} := \{A_1, \dots, A_m\}$  as a finite alphabet and we will often refer to a finite product of matrices from this set as a *word*. We denote the set of all words  $A_{i_t} \dots A_{i_1}$  of length  $t$  by  $\mathcal{A}^t$ . Contrary to the standard convention in automata theory, our convention is to read a word from right to left. This is in accordance with the order of matrix multiplication. The set of all finite words is denoted by  $\mathcal{A}^*$ ; i.e.,  $\mathcal{A}^* = \bigcup_{t \in \mathbb{Z}^+} \mathcal{A}^t$ .

The basic idea behind our framework is to represent through a graph all the possible occurrences of products that can appear in a run of the dynamical system in (2), and assert via some Lyapunov inequalities that no matter what occurrence appears, the product must remain stable. A convenient way of representing these Lyapunov inequalities is via a directed labeled graph  $G(N, E)$ . Each node of this graph is assigned to a (continuous, positive definite, and homogeneous) Lyapunov function  $V_i(x) : \mathbb{R}^n \rightarrow \mathbb{R}$ , and each edge is labeled by a finite product of matrices, i.e., by a word from the set  $\mathcal{A}^*$ . As illustrated in Figure 1, given two nodes with Lyapunov functions  $V_i(x)$  and  $V_j(x)$  and an arc going from node  $i$  to node  $j$  labeled with the matrix  $A_l$ , we write the Lyapunov inequality:

$$V_j(A_l x) \leq V_i(x) \quad \forall x \in \mathbb{R}^n. \quad (8)$$

The problem that we are interested in is to understand which sets of Lyapunov inequalities imply stability of the switched system in (2). We will answer this question based on the corresponding graph.

For reasons that will become clear shortly, we would like to reduce graphs whose arcs have arbitrary labels from the set  $\mathcal{A}^*$  to graphs whose arcs have labels from the set  $\mathcal{A}$ , i.e., labels of length one. This is explained next.

**DEFINITION 2.1.** *Given a labeled directed graph  $G(N, E)$ , we define its expanded graph  $G^e(N^e, E^e)$  as the outcome of the following procedure. For every edge  $(i, j) \in E$  with*

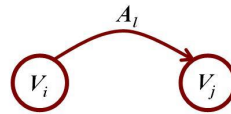

**Figure 1: Graphical representation of Lyapunov inequalities.** The graph above corresponds to the Lyapunov inequality  $V_j(A_l x) \leq V_i(x)$ . Here,  $A_l$  can be a single matrix from  $\mathcal{A}$  or a finite product of matrices from  $\mathcal{A}$ .

label  $A_{i_k} \dots A_{i_1} \in \mathcal{A}^k$ , where  $k > 1$ , we remove the edge  $(i, j)$  and replace it with  $k$  new edges  $(s_q, s_{q+1}) \in E^e \setminus E$ :  $q \in \{0, \dots, k-1\}$ , where  $s_0 = i$  and  $s_k = j$ .<sup>2</sup> (These new edges go from node  $i$  through  $k-1$  newly added nodes  $s_1, \dots, s_{k-1}$  and then to node  $j$ .) We then label the new edges  $(i, s_1), \dots, (s_q, s_{q+1}), \dots, (s_{k-1}, j)$  with  $A_{i_1}, \dots, A_{i_k}$  respectively.

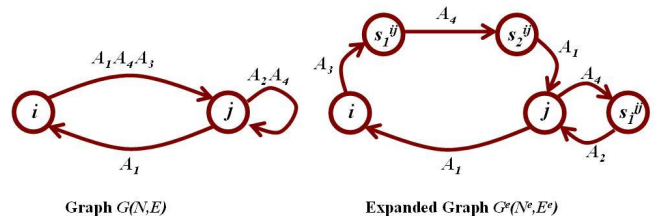

**Figure 2: Graph expansion: edges with labels of length more than one are broken into new edges with labels of length one.**

An example of a graph and its expansion is given in Figure 2. Note that if a graph has only labels of length one, then its expanded graph equals itself. The next definition is central to our development.

**DEFINITION 2.2.** *Given a directed graph  $G(N, E)$  whose arcs are labeled with words from the set  $\mathcal{A}^*$ , we say that the graph is path-complete, if for all finite words  $A_{\sigma_k} \dots A_{\sigma_1}$  of any length  $k$  (i.e., for all words in  $\mathcal{A}^*$ ), there is a directed path in its expanded graph  $G^e(N^e, E^e)$  such that the labels on the edges of this path are the labels  $A_{\sigma_1}$  up to  $A_{\sigma_k}$ .*

In Figure 3, we present eight path-complete graphs on the alphabet  $\mathcal{A} = \{A_1, A_2\}$ . The fact that these graphs are path-complete is obvious for the graphs in (a), (b), (e), (f), and (h), but perhaps not so obvious for graphs in (c), (d), and (g). One way to check if a graph is path-complete is to think of it as a finite automaton by introducing an auxiliary start node (state) with free transitions to every node and by making all the other nodes be accepting states. Then, there are well-known algorithms (see e.g. [11, Chap. 4]) that check whether the language accepted by an automaton is  $\mathcal{A}^*$ , which is equivalent to the graph being path-complete. At least for the cases where the automata are deterministic (i.e., when all outgoing arcs from any node have different

<sup>2</sup>It is understood that the node index  $s_q$  depends on the original nodes  $i$  and  $j$ . To keep the notation simple we write  $s_q$  instead of  $s_q^{ij}$ .

labels), these algorithms are very efficient. (They run in  $O(|N|^2)$  time.) Similar algorithms exist in the symbolic dynamics literature; see e.g. [19, Chap. 3]. Our interest in path-complete graphs stems from the Theorem 2.4 below that establishes that any such graph gives a method for approximation of the JSR. We introduce one last definition before we state this theorem.

**DEFINITION 2.3.** *Let  $\mathcal{A} = \{A_1, \dots, A_m\}$  be a set of matrices. Given a path-complete graph  $G(N, E)$  and  $|N|$  functions  $V_i(x)$ , we say that  $\{V_i(x) \mid i = 1, \dots, |N|\}$  is a Piecewise Lyapunov Function (PLF) associated with  $G(N, E)$  if*

$$V_j(L(e)x) \leq V_i(x) \quad \forall x \in \mathbb{R}^n, \quad \forall e \in E,$$

where  $L(e) \in \mathcal{A}^*$  is the label associated with edge  $e \in E$  going from node  $i$  to node  $j$ .

**THEOREM 2.4.** *Consider a finite set of matrices  $\mathcal{A} = \{A_1, \dots, A_m\}$ . For a scalar  $\gamma > 0$ , let  $\mathcal{A}_\gamma := \{\gamma A_1, \dots, \gamma A_m\}$ . Let  $G(N, E)$  be a path-complete graph whose edges are labeled with words from  $\mathcal{A}_\gamma^*$ . If there exist positive, continuous, and homogeneous<sup>3</sup> Lyapunov functions  $V_i(x)$ , one per node of the graph, such that  $\{V_i(x) \mid i = 1, \dots, |N|\}$  is a piecewise Lyapunov function associated with  $G(N, E)$ , then  $\rho(\mathcal{A}) \leq \frac{1}{\gamma}$ .*

**PROOF.** We will first prove the claim for the special case where the labels of the arcs of  $G(N, E)$  belong to  $\mathcal{A}_\gamma$  and therefore  $G(N, E) = G^e(N^e, E^e)$ . The general case will be reduced to this case afterwards. Let us take the degree of homogeneity of the Lyapunov functions  $V_i(x)$  to be  $d$ , i.e.,  $V_i(\lambda x) = \lambda^d V_i(x)$  for all  $\lambda \in \mathbb{R}$ . (The actual value of  $d$  is irrelevant.) By positivity, continuity, and homogeneity of  $V_i(x)$ , there exist scalars  $\alpha_i$  and  $\beta_i$  with  $0 < \alpha_i \leq \beta_i$  for  $i = 1, \dots, |N|$ , such that

$$\alpha_i \|x\|^d \leq V_i(x) \leq \beta_i \|x\|^d, \quad (9)$$

for all  $x \in \mathbb{R}^n$  and for all  $i = 1, \dots, |N|$ . Let

$$\xi = \max_{i,j \in \{1, \dots, |N|\}^2} \frac{\beta_i}{\alpha_j}. \quad (10)$$

Now consider an arbitrary product  $A_{\sigma_k} \dots A_{\sigma_1}$  of length  $k$ . Because the graph is path-complete, there will be a directed path corresponding to this product that consists of  $k$  arcs, and goes from some node  $i$  to some node  $j$ . If we write the chain of  $k$  Lyapunov inequalities associated with these arcs (cf. Figure 1), then we get

$$V_j(\gamma^k A_{\sigma_k} \dots A_{\sigma_1} x) \leq V_i(x),$$

which by homogeneity of the Lyapunov functions can be rearranged to

$$\left( \frac{V_j(A_{\sigma_k} \dots A_{\sigma_1} x)}{V_i(x)} \right)^{\frac{1}{d}} \leq \frac{1}{\gamma^k}. \quad (11)$$

<sup>3</sup>The requirement of homogeneity can be replaced by radial unboundedness which is implied by homogeneity and positivity. However, since the dynamical system in (2) is homogeneous, there is no conservatism in asking  $V_i(x)$  to be homogeneous [25].

We can now bound the norm of  $A_{\sigma_k} \dots A_{\sigma_1}$  as follows:

$$\begin{aligned} \|A_{\sigma_k} \dots A_{\sigma_1}\| &\leq \max_x \frac{\|A_{\sigma_k} \dots A_{\sigma_1} x\|}{\|x\|} \\ &\leq \left( \frac{\beta_i}{\alpha_j} \right)^{\frac{1}{d}} \max_x \frac{V_j^{\frac{1}{d}}(A_{\sigma_k} \dots A_{\sigma_1} x)}{V_i^{\frac{1}{d}}(x)} \\ &\leq \left( \frac{\beta_i}{\alpha_j} \right)^{\frac{1}{d}} \frac{1}{\gamma^k} \\ &\leq \xi^{\frac{1}{d}} \frac{1}{\gamma^k}, \end{aligned}$$

where the last three inequalities follow from (9), (11), and (10) respectively. From the definition of the JSR in (1), after taking the  $k$ -th root and the limit  $k \rightarrow \infty$ , we get that  $\rho(\mathcal{A}) \leq \frac{1}{\gamma}$  and the claim is established.

Now consider the case where at least one edge of  $G(N, E)$  has a label of length more than one and hence  $G^e(N^e, E^e) \neq G(N, E)$ . We will start with the Lyapunov functions  $V_i(x)$  assigned to the nodes of  $G(N, E)$  and from them we will explicitly construct  $|N^e|$  Lyapunov functions for the nodes of  $G^e(N^e, E^e)$  that satisfy the Lyapunov inequalities associated to the edges in  $E^e$ . Once this is done, in view of our preceding argument and the fact that the edges of  $G^e(N^e, E^e)$  have labels of length one by definition, the proof will be completed.

For  $j \in N^e$ , let us denote the new Lyapunov functions by  $V_j^e(x)$ . It is sufficient to give the construction for the case where  $|N^e| = |N| + 1$ . The result for the general case with  $|N^e| = |N| + l$ ,  $l > 1$ , follows by induction. Let  $s \in N^e \setminus N$  be the added node in the expanded graph, and  $q, r \in N$  be such that  $(s, q) \in E^e$  and  $(r, s) \in E^e$  with  $A_{sq}$  and  $A_{rs}$  as the corresponding labels respectively. Define

$$V_j^e(x) = \begin{cases} V_j(x), & \text{if } j \in N \\ V_q(A_{sq}x), & \text{if } j = s. \end{cases} \quad (12)$$

By construction,  $r$  and  $q$ , and subsequently,  $A_{sq}$  and  $A_{rs}$  are uniquely defined and hence,  $\{V_j^e(x) \mid j \in N^e\}$  is well defined. We only need to show that

$$V_q(A_{sq}x) \leq V_s^e(x) \quad (13)$$

$$V_s^e(A_{rs}x) \leq V_r(x). \quad (14)$$

Inequality (13) follows trivially from (12). Furthermore, it follows from (12) that

$$\begin{aligned} V_s^e(A_{rs}x) &= V_q(A_{sq}A_{rs}x) \\ &\leq V_r(x), \end{aligned}$$

where the inequality follows from the fact that for  $i \in N$ , the functions  $V_i(x)$  satisfy the Lyapunov inequalities of the edges of  $G(N, E)$ .  $\square$

**REMARK 2.1.** *If the matrix  $A_{sq}$  is not invertible, the extended function  $V_j^e(x)$  as defined in (12) will only be positive semidefinite. However, since our goal is to approximate the JSR, we will never be concerned with invertibility of the matrices in  $\mathcal{A}$ . Indeed, since the JSR is continuous in the entries of the matrices [16], we can always perturb the matrices slightly to make them invertible without changing the JSR by much. In particular, for any  $\alpha > 0$ , there exist  $0 < \varepsilon, \delta < \alpha$  such that*

$$\hat{A}_{sq} = \frac{A_{sq} + \delta I}{1 + \varepsilon}$$

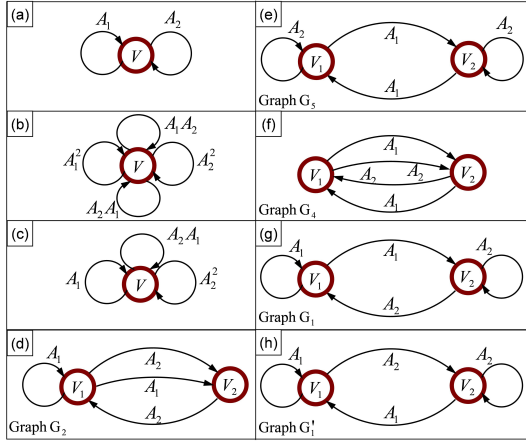

**Figure 3: Examples of path-complete graphs for the alphabet  $\{A_1, A_2\}$ . If Lyapunov functions satisfying the inequalities associated with any of these graphs are found, then we get an upper bound of unity on  $\rho(A_1, A_2)$ .**

is invertible and (12)–(14) are satisfied with  $A_{sq} = \hat{A}_{sq}$ .

To understand the generality of this framework more clearly, let us revisit the path-complete graphs in Figure 3 for the study of the case where the set  $\mathcal{A} = \{A_1, A_2\}$  consists of only two matrices. For all of these graphs if our choice for the Lyapunov functions  $V(x)$  or  $V_1(x)$  and  $V_2(x)$  are quadratic functions or sum of squares polynomial functions, then we can formulate the well-established semidefinite programs that search for these candidate Lyapunov functions.

The graph in (a), which is the simplest one, corresponds to the well-known common Lyapunov function approach. The graph in (b) is a common Lyapunov function applied to all products of length two. This graph also obviously implies stability.<sup>4</sup> But the graph in (c) tells us that if we find a Lyapunov function that decreases whenever  $A_1$ ,  $A_2^2$ , and  $A_2A_1$  are applied (but with no requirement when  $A_1A_2$  is applied), then we still get stability. This is a priori not so obvious and we believe this approach has not appeared in the literature before. We will later prove (Theorem 5.2) a bound for the quality of approximation of path-complete graphs of this type, where a common Lyapunov function is required to decrease with respect to products of different lengths. The graph in (c) is also an example that explains why we needed the expansion process. Note that for the unexpanded graph, there is no path for the word  $A_1A_2$  or any succession of the word  $A_1A_2$ , or for any word of the form  $A_2^{2k-1}$ ,  $k \in \mathbb{N}$ . However, one can check that in the expanded graph of graph (c), there is a path for every finite word, and this in turn allows us to conclude stability from the Lyapunov inequalities of graph (c).

Let us comment now on the graphs with two nodes and four arcs, which each impose four Lyapunov inequalities. We can show that if  $V_1(x)$  and  $V_2(x)$  satisfy the inequalities of any of the graphs (d), (e), (f), or (g), then  $\max\{V_1(x), V_2(x)\}$  is a common Lyapunov function for the switched system. If

<sup>4</sup>By slight abuse of terminology, we say that a graph implies stability meaning (of course) that the associated Lyapunov inequalities imply stability.

$V_1(x)$  and  $V_2(x)$  satisfy the inequalities of any of the graphs in (e), (f), and (h), then  $\min\{V_1(x), V_2(x)\}$  is a common Lyapunov function. These arguments serve as alternative proofs of stability and in the case where  $V_1$  and  $V_2$  are quadratic functions, they correspond to the works in [13], [12], [10], [14]. The next two corollaries prove these statements in a more general setting.

**COROLLARY 2.5.** *Consider a set of  $m$  matrices and the switched linear system in (2) or (3). If there exist  $k$  positive definite matrices  $P_j$  such that*

$$\forall \{i, k\} \in \{1, \dots, m\}^2, \exists j \in \{1, \dots, m\} \text{ such that } \gamma^2 A_i^T P_j A_i \preceq P_k, \quad (15)$$

for some  $\gamma > 1$ , then the system is absolutely asymptotically stable. Moreover, the pointwise minimum

$$\min\{x^T P_1 x, \dots, x^T P_k x\}$$

of the quadratic functions serves as a common Lyapunov function.

**PROOF.** The inequalities in (15) imply that every node of the associated graph has outgoing edges labeled with all the different  $m$  matrices. Therefore, it is obvious that the graph is path-complete. The proof that the pointwise minimum of the quadratics is a common Lyapunov function is easy and left to the reader.  $\square$

**COROLLARY 2.6.** *Consider a set of  $m$  matrices and the switched linear system in (2) or (3). If there exist  $k$  positive definite matrices  $P_j$  such that*

$$\forall \{i, j\} \in \{1, \dots, m\}^2, \exists k \in \{1, \dots, m\} \text{ such that } \gamma^2 A_i^T P_j A_i \preceq P_k, \quad (16)$$

for some  $\gamma > 1$ , then the system is absolutely asymptotically stable. Moreover, the pointwise maximum

$$\max\{x^T P_1 x, \dots, x^T P_k x\}$$

of the quadratic functions serves as a common Lyapunov function.

**PROOF.** The inequalities in (16) imply that every node of the associated graph has incoming edges labeled with all the different  $m$  matrices. This implies that the associated graph is path-complete. To see this, consider any product  $A_{i_k} \dots A_{i_1}$  and consider a new graph obtained by reversing the directions of all the edges. Since this new graph has now outgoing edges with all different labels for every node, it is clearly path-complete and in particular it has a path for the backwards word  $A_{i_1} \dots A_{i_k}$ . If we now trace this path backwards, we get exactly a path in the original graph for the word  $A_{i_k} \dots A_{i_1}$ .

The proof that the pointwise maximum of the quadratics is a common Lyapunov function is easy and again left to the reader.  $\square$

**REMARK 2.2.** *The linear matrix inequalities in (15) and (16) are (convex) sufficient conditions for existence of min-of-quadratics or max-of-quadratics Lyapunov functions. The converse is not true. The works in [13], [12], [10], [14] have additional multipliers in (15) and (16) that make the inequalities non-convex but when solved with a heuristic method contain a larger family of min-of-quadratics and max-of-quadratics Lyapunov functions. Even if the non-convex inequalities with multipliers could be solved exactly, except for*

special cases where the  $\mathcal{S}$ -procedure is exact (e.g., the case of two quadratic functions), these methods still do not completely characterize min-of-quadratics and max-of-quadratics functions.

REMARK 2.3. Two other well-established references in the literature that (when specialized to the analysis of arbitrary switched linear systems) turn out to be particular classes of path-complete graphs are the work in [17] on “path-dependent quadratic Lyapunov functions”, and the work in [8] on “parameter dependent Lyapunov functions”. In fact, the LMIs suggested in these works are special cases of Corollary 2.5 and 2.6 respectively, hence revealing a connection to the min/max-of-quadratics type Lyapunov functions. We will elaborate further on this connection in an extended version of this work.

When we have so many different ways of imposing conditions for stability, it is natural to ask which ones are better. This seems to be a hard question in general, but we have studied in detail all the path-complete graphs with two nodes that imply stability for the case of a switched system with two matrices. This is the subject of the next section. The connections between the bounds obtained from these graphs are not always obvious. For example, we will see that the graphs (a), (e), and (f) always give the same bound on the joint spectral radius; i.e., one graph will succeed in proving stability if and only if the other will. So, there is no point in increasing the number of decision variables and the number of constraints and impose (e) or (f) in place of (a). The same is true for the graphs in (c) and (d), which makes graph (c) preferable to graph (d). (See Proposition 3.2.)

### 3. PATH-COMPLETE GRAPHS WITH TWO NODES

In this section, we characterize and compare all the path-complete graphs consisting of two nodes, an alphabet set  $\mathcal{A} = \{A_1, A_2\}$ , and arc labels of unit length. We refer the reader to [23], [24] for a more general understanding of how the Lyapunov inequalities associated to certain pairs of graphs relate to each other.

#### 3.1 The set of path-complete graphs

The next lemma establishes that for thorough analysis of the case of two matrices and two nodes, we only need to examine graphs with four or less arcs.

LEMMA 3.1. Let  $G(\{1, 2\}, E)$  be a path-complete graph for  $\mathcal{A} = \{A_1, A_2\}$  with labels of length one. Let  $\{V_1, V_2\}$  be a piecewise Lyapunov function for  $G$ . If  $|E| > 4$ , then, either

- (i) there exists  $\hat{e} \in E$  such that  $G(\{1, 2\}, E \setminus \hat{e})$  is a path-complete graph,
- (ii) either  $V_1$  or  $V_2$  or both are common Lyapunov functions for  $\mathcal{A}$ .

PROOF. If node 1 has more than one self-arc, then either these arcs have the same label, in which case one of them can be removed without changing the output set of words, or, they have different labels, in which case  $V_1$  is a Lyapunov function for  $\mathcal{A}$ . By symmetry, the same argument holds for node 2. It remains to present a proof for the case where no node has more than one self-arc. If  $|E| > 4$ , then at least one node has three or more outgoing arcs. Without loss of generality let node 1 be as such,  $e_1, e_2$ , and  $e_3$  be

the corresponding arcs, and  $L(e_1) = L(e_2) = A_1$ . Let  $\mathcal{D}(e)$  denote the destination node of  $e \in E$ . If  $\mathcal{D}(e_1) = \mathcal{D}(e_2) = 2$ , then  $e_1$  (or  $e_2$ ) can be removed without changing the output set. If  $\mathcal{D}(e_1) \neq \mathcal{D}(e_2)$ , assume, without loss of generality, that  $\mathcal{D}(e_1) = 1$  and  $\mathcal{D}(e_2) = 2$ . Now, if  $L(e_3) = A_1$ , then regardless of its destination node,  $e_3$  can be removed. The only remaining possibility is that  $L(e_3) = A_2$  and  $\mathcal{D}(e_3) = 2$ . In this case, it can be verified that  $e_2$  can be removed without affecting the output set of words.  $\square$

It can be verified that a path-complete graph with two nodes and less than four arcs must necessarily place two arcs with different labels on one node, which necessitates existence of a single Lyapunov function for the underlying switched system. Since we are interested in exploiting the favorable properties of Piecewise Lyapunov Functions (PLFs) in approximation of the JSR we will focus on graphs with four arcs.

#### 3.2 Comparison of performance

It can be verified that for path-complete graphs with two nodes, four arcs, and two matrices, and without multiple self loops on a single node, there are a total of nine distinct graph topologies to consider (several redundant cases arise which can be shown to be equivalent to one of the nine cases via swapping the nodes). Of the nine graphs, six have the property that every node has two incoming arcs with different labels—we call these *primal graphs*; six have the property that every node has two outgoing arcs with different labels—we call these *dual graphs*; and three are in both the primal and the dual set of graphs—we call these *self-dual graphs*. The self-dual graphs are least interesting to us since, as we will show, they necessitate existence of a single Lyapunov function for  $\mathcal{A}$  (cf. Proposition 3.2, equation (19)).

The (strictly) primal graphs are Graph  $G_1$  (Figure 3 (g)), Graph  $G_2$ , (Figure 3 (d)), and Graph  $G_3$  which is obtained by swapping the roles of  $A_1$  and  $A_2$  in  $G_2$  (not shown). The self-dual graphs are Graph  $G_4$  (Figure 3 (f)), Graph  $G_5$  (Figure 3 (e)), and Graph  $G_6$  which is obtained by swapping the roles of  $A_1$  and  $A_2$  in  $G_5$  (not shown). The (strictly) dual graphs are obtained by reversing the direction of the arrows in the primals and are denoted by  $G'_1, G'_2, G'_3$  respectively. For instance,  $G'_1$  is the graph shown in Figure 3 (h). The rest of the dual graphs are not shown.

Note that all of these graphs perform at least as well as a common Lyapunov function because we can always take  $V_1(x) = V_2(x)$ . We know from Corollary 2.6 and 2.5 that the primal graphs imply that  $\max\{V_1(x), V_2(x)\}$  is a Lyapunov function, whereas, the dual graphs imply that  $\min\{V_1(x), V_2(x)\}$  is a Lyapunov function.

**Notation:** Given a set of matrices  $\mathcal{A} = \{A_1, \dots, A_m\}$ , a path-complete graph  $G(N, E)$ , and a class of functions  $\mathcal{V}$ , we denote by  $\hat{\rho}_{\mathcal{V}, G}(\mathcal{A})$ , the upperbound on the JSR of  $\mathcal{A}$  that can be obtained by numerical optimization of PLFs  $V_i \in \mathcal{V}$ ,  $i \in \{1, \dots, |N|\}$ , defined over  $G$ . With a slight abuse of notation, we denote by  $\hat{\rho}_{\mathcal{V}}(\mathcal{A})$ , the upperbound that is obtained by using a common Lyapunov function  $V \in \mathcal{V}$ .

PROPOSITION 3.2. Consider  $\mathcal{A} = \{A_1, A_2\}$ , and let  $\mathcal{A}_2 = \{A_1, A_2A_1, A_2^2\}$ ,  $\mathcal{A}'_2 = \{A_1, A_1A_2, A_2^2\}$ ,  $\mathcal{A}_3 = \{A_2, A_1A_2, A_1^2\}$ ,  $\mathcal{A}'_3 = \{A_2, A_2A_1, A_1^2\}$ . For  $\mathcal{S} \in \{\mathcal{A}_i, \mathcal{A}'_i \mid i = 2, 3\}$ , let  $G_{\mathcal{S}} = G(\{1\}, E_{\mathcal{S}})$  be the graph with one node and three edges such that  $\{L(e) \mid e \in E_{\mathcal{S}}\} = \mathcal{S}$ .

Then, we have

$$\hat{\rho}_{\mathcal{V}, G_2}(\mathcal{A}) = \hat{\rho}_{\mathcal{V}, G_{A_2}}(\mathcal{A}), \quad \hat{\rho}_{\mathcal{V}, G_3}(\mathcal{A}) = \hat{\rho}_{\mathcal{V}, G_{A_3}}(\mathcal{A}), \quad (17)$$

$$\hat{\rho}_{\mathcal{V}, G'_2}(\mathcal{A}) = \hat{\rho}_{\mathcal{V}, G_{A'_2}}(\mathcal{A}), \quad \hat{\rho}_{\mathcal{V}, G'_3}(\mathcal{A}) = \hat{\rho}_{\mathcal{V}, G_{A'_3}}(\mathcal{A}), \quad (18)$$

$$\hat{\rho}_{\mathcal{V}, G_i}(\mathcal{A}) = \hat{\rho}_{\mathcal{V}}(\mathcal{A}), \quad i = 4, 5, 6, \quad (19)$$

$$\hat{\rho}_{\mathcal{V}, G_1}(\mathcal{A}) = \hat{\rho}_{\mathcal{V}, G'_1}(\mathcal{A}). \quad (20)$$

PROOF. We start by proving the left equality in (17). Let  $\{V_1, V_2\}$  be a PLF associated with  $G_2$ . It can be verified that  $V_1$  is a Lyapunov function associated with  $G_{A_2}$ , and therefore,  $\hat{\rho}_{\mathcal{V}, G_{A_2}}(\mathcal{A}) \leq \hat{\rho}_{\mathcal{V}, G_2}(\mathcal{A})$ . Similarly, if  $V \in \mathcal{V}$  is a Lyapunov function associated with  $G_{A_2}$ , then one can check that  $\{V_1, V_2 \mid V_1(x) = V(x), V_2(x) = V(A_2x)\}$  is a PLF associated with  $G_2$ , and hence,  $\hat{\rho}_{\mathcal{V}, G_{A_2}}(\mathcal{A}) \geq \hat{\rho}_{\mathcal{V}, G_2}(\mathcal{A})$ . The proofs for the rest of the equalities in (17) and (18) are analogous. The proof of (19) is as follows. Let  $\{V_1, V_2\}$  be a PLF associated with  $G_i$ ,  $i = 4, 5, 6$ . It can be then verified that  $V = V_1 + V_2$  is a common Lyapunov function for  $\mathcal{A}$ , and hence,  $\hat{\rho}_{\mathcal{V}, G_i}(\mathcal{A}) \geq \hat{\rho}_{\mathcal{V}}(\mathcal{A})$ ,  $i = 4, 5, 6$ . The other direction is trivial: If  $V \in \mathcal{V}$  is a common Lyapunov function for  $\mathcal{A}$ , then  $\{V_1, V_2 \mid V_1 = V_2 = V\}$  is a PLF associated with  $G_i$ , and hence,  $\hat{\rho}_{\mathcal{V}, G_i}(\mathcal{A}) \leq \hat{\rho}_{\mathcal{V}}(\mathcal{A})$ ,  $i = 4, 5, 6$ . The proof of (20) is based on similar arguments; the PLFs associated with  $G_1$  and  $G'_1$  can be derived from one another via  $V'_1(A_1x) = V_1(x)$ , and  $V'_2(A_2x) = V_2(x)$ .  $\square$

REMARK 3.1. Proposition 3.2 (20) establishes the equivalence of the bounds obtained from the primal and dual graphs  $G_1$  and  $G'_1$  for general class of Lyapunov functions. This, however, is not true for graphs  $G_2$  and  $G_3$  and there exist examples for which

$$\begin{aligned} \hat{\rho}_{\mathcal{V}, G_2}(\mathcal{A}) &\neq \hat{\rho}_{\mathcal{V}, G'_2}(\mathcal{A}), \\ \hat{\rho}_{\mathcal{V}, G_3}(\mathcal{A}) &\neq \hat{\rho}_{\mathcal{V}, G'_3}(\mathcal{A}). \end{aligned}$$

The three primal graphs  $G_1$ ,  $G_2$ , and  $G_3$  can outperform one another depending on the problem data. We ran 100 test cases on random  $5 \times 5$  matrices with elements uniformly distributed in  $[-1, 1]$ , and observed that  $G_1$  resulted in the least conservative bound on the JSR in approximately 77% of the test case, and  $G_2$  and  $G_3$  in approximately 53% of the test cases (the overlap is due to ties). Furthermore,  $\hat{\rho}_{\mathcal{V}, G_1}(\{A_1, A_2\})$  is invariant under (i) relabeling of  $A_1$  and  $A_2$  (obvious), and (ii) transposing of  $A_1$  and  $A_2$  (Corollary 4.2). These are desirable properties which fail to hold for  $G_2$  and  $G_3$  or their duals. Motivated by these observations, we generalize  $G_1$  and its dual  $G'_1$  to the case of  $m$  matrices and  $m$  Lyapunov functions and establish that they have certain appealing properties. We will prove in the next section (cf. Theorem 4.3) that these graphs always perform better than a common Lyapunov function in 2 steps (i.e., for  $\mathcal{A}^2 = \{A_1^2, A_1A_2, A_2A_1, A_2^2\}$ ), whereas, this fact is not true for  $G_2$  and  $G_3$  (or their duals).

## 4. A PARTICULAR FAMILY OF PATH-COMplete GRAPHS

The framework of path-complete graphs provides a multitude of semidefinite programming based techniques for the approximation of the JSR whose performance vary with computational cost. For instance, as we increase the number of nodes of the graph, or the degree of the polynomial

Lyapunov functions assigned to the nodes, or the number of arcs of the graph that instead of labels of length one have labels of higher length, we clearly obtain better results but at a higher computational cost. Many of these approximation techniques are asymptotically tight, so in theory they can be used to achieve any desired accuracy of approximation. For example,

$$\hat{\rho}_{\mathcal{V}^{SOS, 2d}}(\mathcal{A}) \rightarrow \rho(\mathcal{A}) \text{ as } 2d \rightarrow \infty,$$

where  $\mathcal{V}^{SOS, 2d}$  denotes the class of sum of squares homogeneous polynomial Lyapunov functions of degree  $2d$ . (Recall our notation for bounds from Section 3.2.) It is also true that a common quadratic Lyapunov function for products of higher length achieves the true JSR asymptotically [16]; i.e.<sup>5</sup>,

$$\sqrt[t]{\hat{\rho}_{\mathcal{V}^2}(\mathcal{A}^t)} \rightarrow \rho(\mathcal{A}) \text{ as } t \rightarrow \infty.$$

Nevertheless, it is desirable for practical purposes to identify a class of path-complete graphs that provide a good tradeoff between quality of approximation and computational cost. Towards this objective, we propose the use of  $m$  quadratic functions  $x^T P_i x$  satisfying the set of linear matrix inequalities (LMIs)

$$\begin{aligned} P_i &> 0 \quad \forall i = 1, \dots, m, \\ \gamma^2 A_i^T P_j A_i &\preceq P_j \quad \forall i, j = \{1, \dots, m\}^2 \end{aligned} \quad (21)$$

or the set of LMIs

$$\begin{aligned} P_i &> 0 \quad \forall i = 1, \dots, m, \\ \gamma^2 A_i^T P_i A_i &\preceq P_j \quad \forall i, j = \{1, \dots, m\}^2 \end{aligned} \quad (22)$$

for the approximation of the JSR of a set of  $m$  matrices. Observe from Corollary 2.5 and Corollary 2.6 that the first LMIs give rise to max-of-quadratics Lyapunov functions, whereas the second LMIs lead to min-of-quadratics Lyapunov functions. Throughout this section, we denote the path-complete graphs associated with (21) and (22) with  $G_1$  and  $G'_1$  respectively. For the case  $m = 2$ , our notation is consistent with the previous section and these graphs are illustrated in Figure 3 (g) and (h). Note that we can obtain  $G_1$  and  $G'_1$  from each other by reversing the direction of the edges. For this reason, we say that these graphs are dual to each other. We will prove later in this section that the approximation bound obtained by these graphs (i.e., the reciprocal of the largest  $\gamma$  for which the LMIs (21) or (22) hold) is always the same and lies within a multiplicative factor of  $\frac{1}{\sqrt[n]{n}}$  of the true JSR, where  $n$  is the dimension of the matrices.

### 4.1 Duality and invariance under transposition

In [9], [10], it is shown that absolute asymptotic stability of the linear difference inclusion in (3) defined by the matrices  $\mathcal{A} = \{A_1, \dots, A_m\}$  is equivalent to absolute asymptotic stability of (3) for the transposed matrices  $\mathcal{A}^T := \{A_1^T, \dots, A_m^T\}$ . Note that this fact is obvious from the definition of the JSR in (1), since  $\rho(\mathcal{A}) = \rho(\mathcal{A}^T)$ . It is also well-known that

$$\hat{\rho}_{\mathcal{V}^2}(\mathcal{A}) = \hat{\rho}_{\mathcal{V}^2}(\mathcal{A}^T).$$

<sup>5</sup>By  $\mathcal{V}^2$  we denote the class of quadratic homogeneous polynomials. We drop the superscript ‘‘SOS’’ because nonnegative quadratic polynomials are always sums of squares.



Indeed, if  $x^T P x$  is a common quadratic Lyapunov function for the set  $\mathcal{A}$ , then  $x^T P^{-1} x$  is a common quadratic Lyapunov function for the set  $\mathcal{A}^T$ . However, this nice property is not true for the bound obtained from some other techniques. For example<sup>6</sup>,

$$\hat{\rho}_{\mathcal{V}^2, \mathcal{A}} \neq \hat{\rho}_{\mathcal{V}^2, \mathcal{A}^T}. \quad (23)$$

Similarly, the bound obtained by non-convex inequalities proposed in [9] is not invariant under transposing the matrices. For such methods, one would have to run the numerical optimization twice—once for the set  $\mathcal{A}$  and once for the set  $\mathcal{A}^T$ —and then pick the better bound of the two. We will show that by contrast, the bound obtained from the LMIs in (21) and (22) are invariant under transposing the matrices. Before we do that, let us prove a general result, which states that the bounds resulting from a path-complete graph (with quadratic Lyapunov functions as nodes) and its dual are always the same, provided that these bounds are invariant under transposing the matrices.

**THEOREM 4.1.** *Let  $G(N, E)$  be a path-complete graph, and let its dual graph  $G'(N, E')$  be the graph obtained by reversing the direction of the edges and the order of the matrices in the labels of each edge. If*

$$\hat{\rho}_{\mathcal{V}^2, G}(\mathcal{A}) = \hat{\rho}_{\mathcal{V}^2, G}(\mathcal{A}^T), \quad (24)$$

then, the two following equations hold:

$$\hat{\rho}_{\mathcal{V}^2, G}(\mathcal{A}) = \hat{\rho}_{\mathcal{V}^2, G'}(\mathcal{A}), \quad (25)$$

$$\hat{\rho}_{\mathcal{V}^2, G'}(\mathcal{A}) = \hat{\rho}_{\mathcal{V}^2, G'}(\mathcal{A}^T). \quad (26)$$

**PROOF.** For ease of notation, we prove the claim for the case where the labels of the edges of  $G(N, E)$  have length one. The proof of the general case is identical.

Pick an arbitrary edge  $(i, j) \in E$  going from node  $i$  to node  $j$ , and let the associated constraint be given by

$$A_i^T P_j A_i \preceq P_i,$$

for some  $A_i \in \mathcal{A}$ . If this inequality holds for some positive definite matrices  $P_i$  and  $P_j$ , then because  $\hat{\rho}_{\mathcal{V}^2, G}(\mathcal{A}) = \hat{\rho}_{\mathcal{V}^2, G}(\mathcal{A}^T)$ , we will have

$$A_i \tilde{P}_j A_i^T \preceq \tilde{P}_i,$$

for some other positive definite matrices  $\tilde{P}_i$  and  $\tilde{P}_j$ . By applying the Schur complement twice, we get that the last inequality implies

$$A_i^T \tilde{P}_i^{-1} A_i \preceq \tilde{P}_j^{-1}.$$

But this inequality shows that  $\tilde{P}_i^{-1}$  and  $\tilde{P}_j^{-1}$  satisfy the constraint associated with edge  $(j, i) \in E'$ . Therefore, the claim in (25) is established. The equality in (26) follows directly from (24) and (25).  $\square$

**COROLLARY 4.2.** *For the path-complete graphs  $G_1$  and  $G_2$  associated with the LMIs in (21) and (22), we have*

$$\hat{\rho}_{\mathcal{V}^2, G_1}(\mathcal{A}) = \hat{\rho}_{\mathcal{V}^2, G_1}(\mathcal{A}^T) = \hat{\rho}_{\mathcal{V}^2, G_1'}(\mathcal{A}) = \hat{\rho}_{\mathcal{V}^2, G_1'}(\mathcal{A}^T). \quad (27)$$

<sup>6</sup>We have examples that show the statement in (23), which we do not present because of space limitations. See [9] for such an example in the continuous time setting.

**PROOF.** We prove the leftmost equality. The other two equalities then follow from Theorem 4.1. Let  $P_i, i = 1, \dots, m$  satisfy the LMIs in (21) for the set of matrices  $\mathcal{A}$ . The reader can check that

$$\tilde{P}_i = A_i P_i^{-1} A_i^T, \quad i = 1, \dots, m$$

satisfy the LMIs in (21) for the set of matrices  $\mathcal{A}^T$ .  $\square$

We next prove a bound on the quality of approximation of the estimate resulting from the LMIs in (21) and (22).

**THEOREM 4.3.** *Let  $\mathcal{A}$  be a set of  $m$  matrices in  $\mathbb{R}^{n \times n}$  with JSR  $\rho(\mathcal{A})$ . Let  $\hat{\rho}_{\mathcal{V}^2, G_1}(\mathcal{A})$  and  $\hat{\rho}_{\mathcal{V}^2, G_1'}(\mathcal{A})$  be the bounds on the JSR obtained from the LMIs in (21) and (22) respectively. Then,*

$$\frac{1}{\sqrt[4]{n}} \hat{\rho}_{\mathcal{V}^2, G_1}(\mathcal{A}) \leq \rho(\mathcal{A}) \leq \hat{\rho}_{\mathcal{V}^2, G_1}(\mathcal{A}), \quad (28)$$

and

$$\frac{1}{\sqrt[4]{n}} \hat{\rho}_{\mathcal{V}^2, G_1'}(\mathcal{A}) \leq \rho(\mathcal{A}) \leq \hat{\rho}_{\mathcal{V}^2, G_1'}(\mathcal{A}). \quad (29)$$

**PROOF.** By Corollary 4.2,  $\hat{\rho}_{\mathcal{V}^2, G_1}(\mathcal{A}) = \hat{\rho}_{\mathcal{V}^2, G_1'}(\mathcal{A})$  and therefore it is enough to prove (28). The right inequality in (28) is an obvious consequence of  $G_1$  being a path-complete graph (Theorem 2.4). To prove the left inequality, consider the set  $\mathcal{A}^2$  consisting of all  $m^2$  products of length two. In view of (6), a common quadratic Lyapunov function for this set satisfies the bound

$$\frac{1}{\sqrt{n}} \hat{\rho}_{\mathcal{V}^2}(\mathcal{A}^2) \leq \rho(\mathcal{A}^2).$$

It is easy to show that

$$\rho(\mathcal{A}^2) = \rho^2(\mathcal{A}).$$

See e.g. [16]. Therefore,

$$\frac{1}{\sqrt[4]{n}} \hat{\rho}_{\mathcal{V}^2}^{\frac{1}{2}}(\mathcal{A}^2) \leq \rho(\mathcal{A}). \quad (30)$$

Now suppose for some  $\gamma > 0$ ,  $x^T Q x$  is a common quadratic Lyapunov function for the matrices in  $\mathcal{A}_{\gamma}^2$ ; i.e., it satisfies

$$\begin{aligned} Q &\succ 0 \\ \gamma^4 (A_i A_j)^T Q A_i A_j &\preceq Q \quad \forall i, j = \{1, \dots, m\}^2. \end{aligned}$$

Then, we leave it to the reader to check that

$$P_i = Q + A_i^T Q A_i, \quad i = 1, \dots, m$$

satisfy (21). Hence,

$$\hat{\rho}_{\mathcal{V}^2, G_1}(\mathcal{A}) \leq \hat{\rho}_{\mathcal{V}^2}^{\frac{1}{2}}(\mathcal{A}^2),$$

and in view of (30) the claim is established.  $\square$

Note that the bounds in (28) and (29) are independent of the number of matrices. Moreover, we remark that these bounds are tighter, in terms of their dependence on  $n$ , than the known bounds for  $\hat{\rho}_{\mathcal{V}^2, \mathcal{A}^2}$  for any finite degree  $2d$  of the sum of squares polynomials. The reader can check that the bound in (7) goes asymptotically as  $\frac{1}{\sqrt{n}}$ . Numerical evidence suggests that the performance of both the bound obtained by sum of squares polynomials and the bound obtained by the LMIs in (21) and (22) is much better than the provable bounds in (7) and in Theorem 4.3. The problem of improving these bounds or establishing their tightness is open. It



goes without saying that instead of quadratic functions, we can associate sum of squares polynomials to the nodes of  $G_1$  and obtain a more powerful technique for which we can also prove better bounds with the exact same arguments.

## 4.2 Numerical example

In the proof of Theorem 4.3, we essentially showed that the bound obtained from LMIs in (21) is tighter than the bound obtained from a common quadratic applied to products of length two. The example below shows that the LMIs in (21) can in fact do better than a common quadratic applied to products of *any* finite length.

EXAMPLE 4.1. Consider the set of matrices  $\mathcal{A} = \{A_1, A_2\}$ , with

$$A_1 = \begin{bmatrix} 1 & 0 \\ 1 & 0 \end{bmatrix}, \quad A_2 = \begin{bmatrix} 0 & 1 \\ 0 & -1 \end{bmatrix}.$$

This is a benchmark set of matrices that has been studied in [3], [21], [2] because it gives the worst case approximation ratio of a common quadratic Lyapunov function. Indeed, it is easy to show that  $\rho(\mathcal{A}) = 1$ , but  $\hat{\rho}_{\mathcal{V}^2}(\mathcal{A}) = \sqrt{2}$ . Moreover, the bound obtained by a common quadratic function applied to the set  $\mathcal{A}^t$  is

$$\hat{\rho}_{\mathcal{V}^2}^{\frac{1}{t}}(\mathcal{A}^t) = 2^{1/2t},$$

which for no finite value of  $t$  is exact. On the other hand, we show that the LMIs in (21) give the exact bound; i.e.,  $\hat{\rho}_{\mathcal{V}^2, G_1}(\mathcal{A}) = 1$ . Due to the simple structure of  $A_1$  and  $A_2$ , we can even give an analytical expression for our Lyapunov functions. Given any  $\varepsilon > 0$ , the LMIs in (21) with  $\gamma = 1/(1 + \varepsilon)$  are feasible with

$$P_1 = \begin{bmatrix} a & 0 \\ 0 & b \end{bmatrix}, \quad P_2 = \begin{bmatrix} b & 0 \\ 0 & a \end{bmatrix},$$

for any  $b > 0$  and  $a > b/2\varepsilon$ .

## 5. CONVERSE LYAPUNOV THEOREMS AND MORE APPROXIMATION BOUNDS

It is well-known that existence of a Lyapunov function which is the pointwise maximum of quadratics is not only sufficient but also necessary for absolute asymptotic stability of (2) or (3) [20]. This is a very intuitive fact, if we recall that switched systems of type (2) and (3) always admit a convex Lyapunov function. Indeed, if we take “enough” quadratics, the convex and compact unit sublevel set of a convex Lyapunov function can be approximated arbitrarily well with sublevel sets of max-of-quadratics Lyapunov functions, which are intersections of ellipsoids. An obvious consequence of this fact is that the bound obtained from max-of-quadratics Lyapunov functions is asymptotically tight for the approximation of the JSR. However, this converse Lyapunov theorem does not answer two natural questions of importance in practice: (i) How many quadratic functions do we need to achieve a desired quality of approximation? (ii) Can we search for these quadratic functions via semidefinite programming or do we need to resort to non-convex formulations? Our next theorem provides an answer to these questions. We then prove a similar result for another interesting subclass of our methods. Due to length constraints, we only briefly sketch the common idea behind the two theorems. The interested reader can find the full proofs in the journal version of the present paper.

THEOREM 5.1. Let  $\mathcal{A}$  be any set of  $m$  matrices in  $\mathbb{R}^{n \times n}$ . Given any positive integer  $l$ , there exists an explicit path-complete graph  $G$  consisting of  $m^{l-1}$  nodes assigned to quadratic Lyapunov functions and  $m^l$  arcs with labels of length one such that the linear matrix inequalities associated with  $G$  imply existence of a max-of-quadratics Lyapunov function and the resulting bound obtained from the LMIs satisfies

$$\frac{1}{\sqrt[l]{n}} \hat{\rho}_{\mathcal{V}^2, G}(\mathcal{A}) \leq \rho(\mathcal{A}) \leq \hat{\rho}_{\mathcal{V}^2, G}(\mathcal{A}). \quad (31)$$

THEOREM 5.2. Let  $\mathcal{A}$  be a set of matrices in  $\mathbb{R}^{n \times n}$ . Let  $\tilde{G}(\{1\}, E)$  be a path-complete graph, and  $l$  be the length of the shortest word in  $\tilde{\mathcal{A}} = \{L(e) : e \in E\}$ . Then  $\hat{\rho}_{\mathcal{V}^2, \tilde{G}}(\mathcal{A})$  provides an estimate of  $\rho(\mathcal{A})$  that satisfies

$$\frac{1}{\sqrt[l]{n}} \hat{\rho}_{\mathcal{V}^2, \tilde{G}}(\mathcal{A}) \leq \rho(\mathcal{A}) \leq \hat{\rho}_{\mathcal{V}^2, \tilde{G}}(\mathcal{A}).$$

PROOF. (Sketch of the proof of Theorems 5.1 and 5.2) For the proof of Theorem 5.1, we define the graph  $G$  as follows: there is one node  $v_w$  for each word  $w \in \{1, \dots, m\}^{l-1}$ . For each node  $v_w$  and each index  $j \in \{1, \dots, m\}$ , there is an edge with the label  $A_j$  from  $v_w$  to  $v_{w'}$  iff  $w'j = w$  for some label  $x \in \{1, \dots, m\}$  ( $xw'$  means the concatenation of the label  $x$  with the word  $w'$ ).

Now, for both proofs, denoting the corresponding graph by  $G$ , we show that if  $\mathcal{A}^l$  has a common quadratic Lyapunov function, then

$$\hat{\rho}_{\mathcal{V}^2, G} \leq 1,$$

which implies the result.  $\square$

REMARK 5.1. In view of NP-hardness of approximation of the JSR [27], the fact that the number of quadratic functions and the number of LMIs grow exponentially in  $l$  is to be expected.

## 6. CONCLUSIONS AND FUTURE DIRECTIONS

We studied the use of multiple Lyapunov functions for the formulation of semidefinite programming based approximation algorithms for computing upper bounds on the joint spectral radius of a finite set of matrices (or equivalently establishing absolute asymptotic stability of an arbitrary switched linear system). We introduced the notion of a path-complete graph, which was inspired by well-established concepts in automata theory. We showed that every path-complete graph gives rise to a technique for the approximation of the JSR. This provided a unifying framework that includes many of the previously proposed techniques and also introduces new ones. (In fact, all families of LMIs that we are aware of appear to be particular cases of our method.) We compared the quality of the bound obtained from certain classes of path-complete graphs, including all path-complete graphs with two nodes on an alphabet of two matrices, and also a certain family of dual path-complete graphs. We proposed a specific class of such graphs that appear to work particularly well in practice. We proved that the bound obtained from these graphs is invariant under transposition of the matrices and is always within a multiplicative factor of  $1/\sqrt[l]{n}$  from the true JSR. Finally, we presented two converse Lyapunov theorems, one for a new class of methods that propose the use of a common quadratic Lyapunov function for

a set of words of possibly different lengths, and the other for the well-known methods of minimum and maximum-of-quadratics Lyapunov functions. These theorems yield explicit and systematic constructions of semidefinite programs that achieve any desired accuracy of approximation.

Some of the interesting questions that can be explored in the future are the following. What is the complexity of recognizing path-complete graphs when the underlying finite automata are non-deterministic? What are some other classes of path-complete graphs that lead to new techniques for proving stability of switched systems? How can we compare the performance of different path-complete graphs in a systematic way? Given a set of matrices, a class of Lyapunov functions, and a fixed size for the graph, can we come up with the least conservative topology of a path-complete graph? Within the framework that we proposed, do all the Lyapunov inequalities that prove stability come from path-complete graphs? What are the analogues of the results of this paper for continuous time switched systems? We hope that this work will stimulate further research in these directions.

## 7. REFERENCES

- [1] A. A. Ahmadi. Non-monotonic Lyapunov functions for stability of nonlinear and switched systems: theory and computation. Master's Thesis, Massachusetts Institute of Technology, June 2008. Available from <http://dspace.mit.edu/handle/1721.1/44206>.
- [2] A. A. Ahmadi and P. A. Parrilo. Non-monotonic Lyapunov functions for stability of discrete time nonlinear and switched systems. In *Proceedings of the 47<sup>th</sup> IEEE Conference on Decision and Control*, 2008.
- [3] T. Ando and M.-H. Shih. Simultaneous contractibility. *SIAM Journal on Matrix Analysis and Applications*, 19:487–498, 1998.
- [4] V. D. Blondel and Y. Nesterov. Computationally efficient approximations of the joint spectral radius. *SIAM J. Matrix Anal. Appl.*, 27(1):256–272, 2005.
- [5] V. D. Blondel, Y. Nesterov, and J. Theys. On the accuracy of the ellipsoidal norm approximation of the joint spectral radius. *Linear Algebra and its Applications*, 394:91–107, 2005.
- [6] V. D. Blondel and J. N. Tsitsiklis. The boundedness of all products of a pair of matrices is undecidable. *Systems and Control Letters*, 41:135–140, 2000.
- [7] M. S. Branicky. Multiple Lyapunov functions and other analysis tools for switched and hybrid systems. *IEEE Transactions on Automatic Control*, 43(4):475–482, 1998.
- [8] J. Daafouz and J. Bernussou. Parameter dependent Lyapunov functions for discrete time systems with time varying parametric uncertainties. *Systems and Control Letters*, 43(5):355–359, 2001.
- [9] R. Goebel, T. Hu, and A. R. Teel. Dual matrix inequalities in stability and performance analysis of linear differential/difference inclusions. In *Current Trends in Nonlinear Systems and Control*, pages 103–122. 2006.
- [10] R. Goebel, A. R. Teel, T. Hu, and Z. Lin. Conjugate convex Lyapunov functions for dual linear differential inclusions. *IEEE Transactions on Automatic Control*, 51(4):661–666, 2006.
- [11] J. E. Hopcroft, R. Motwani, and J. D. Ullman. *Introduction to automata theory, languages, and computation*. Addison Wesley, 2001.
- [12] T. Hu and Z. Lin. Absolute stability analysis of discrete-time systems with composite quadratic Lyapunov functions. *IEEE Transactions on Automatic Control*, 50(6):781–797, 2005.
- [13] T. Hu, L. Ma, and Z. Li. On several composite quadratic Lyapunov functions for switched systems. In *Proceedings of the 45<sup>th</sup> IEEE Conference on Decision and Control*, 2006.
- [14] T. Hu, L. Ma, and Z. Lin. Stabilization of switched systems via composite quadratic functions. *IEEE Transactions on Automatic Control*, 53(11):2571 – 2585, 2008.
- [15] M. Johansson and A. Rantzer. Computation of piecewise quadratic Lyapunov functions for hybrid systems. *IEEE Transactions on Automatic Control*, 43(4):555–559, 1998.
- [16] R. Jungers. *The joint spectral radius: theory and applications*, volume 385 of *Lecture Notes in Control and Information Sciences*. Springer, 2009.
- [17] J. W. Lee and G. E. Dullerud. Uniform stabilization of discrete-time switched and Markovian jump linear systems. *Automatica*, 42(2):205–218, 2006.
- [18] H. Lin and P. J. Antsaklis. Stability and stabilizability of switched linear systems: a short survey of recent results. In *Proceedings of IEEE International Symposium on Intelligent Control*, 2005.
- [19] D. Lind and B. Marcus. *An introduction to symbolic dynamics and coding*. Cambridge University Press, 1995.
- [20] A. Molchanov and Y. Pyatnitskiy. Criteria of asymptotic stability of differential and difference inclusions encountered in control theory. *Systems and Control Letters*, 13:59–64, 1989.
- [21] P. A. Parrilo and A. Jadbabaie. Approximation of the joint spectral radius using sum of squares. *Linear Algebra and its Applications*, 428(10):2385–2402, 2008.
- [22] V. Y. Protasov, R. M. Jungers, and V. D. Blondel. Joint spectral characteristics of matrices: a conic programming approach. *SIAM Journal on Matrix Analysis and Applications*, 31(4):2146–2162, 2010.
- [23] M. Roozbehani. *Optimization of Lyapunov invariants in analysis and implementation of safety-critical software systems*. PhD thesis, Massachusetts Institute of Technology.
- [24] M. Roozbehani, A. Megretski, E. Frazzoli, and E. Feron. Distributed Lyapunov functions in analysis of graph models of software. *Springer Lecture Notes in Computer Science*, 4981:443–456, 2008.
- [25] L. Rosier. Homogeneous Lyapunov function for homogeneous continuous vector fields. *Systems Control Letters*, 19(6):467–473, 1992.
- [26] G. C. Rota and W. G. Strang. A note on the joint spectral radius. *Indag. Math.*, 22:379–381, 1960.
- [27] J. N. Tsitsiklis and V. Blondel. The Lyapunov exponent and joint spectral radius of pairs of matrices are hard- when not impossible- to compute and to approximate. *Mathematics of Control, Signals, and Systems*, 10:31–40, 1997.