

On Time-Varying Bit-Allocation Maintaining Stability and Performance: A Convex Parameterization

Sridevi V. Sarma, *Member, IEEE*, Munther A. Dahleh, *Fellow, IEEE*, and Srinivasa Salapaka
Member, IEEE

Abstract

In this paper, we analyze and derive conditions for stability of a feedback system in which the plant and feedback controller are separated by a noiseless finite-rate communication channel. We allow for two deterministic classes of reference inputs to excite the system, and derive sufficient conditions for *input-output stability* as a function of the encoding strategy and controller. We first construct an encoder as a quantizer that can have *infinite memory* and can be *time-varying*, in that the strategy it follows to allocate a total of R bits to its inputs, is a function of time. This construction of the quantizer leads to the result that the set of allocation strategies that maintains stability for each class of reference signals is *convex*, allowing the search for the most efficient strategy to ensure stability to be formulated as a convex optimization problem. We then synthesize quantizers and time-varying controllers to minimize the rate required for stability and to track commands. Examples presented in the paper demonstrate how this framework enables computationally efficient methods for simultaneously designing quantizers and controllers for given plants. Furthermore, we observe that our finite memory quantizers that minimize the rate required for stability do not reduce to trivial memoryless bit-allocation strategies.

Index Terms

Input-Output Stability, Quantizer, Channel, Transmission Rate, Bit-Allocation Strategy

I. INTRODUCTION

The classical control paradigm addresses problems where communication between the plant and the controller is essentially perfect. Recently problems in control over networked systems, whose components are connected via noisy communication links that may also induce delays and have finite rate constraints, are emerging. Applications include remote navigation systems (deep-space and sea exploration) and multi-robot control systems (aircraft and spacecraft formation flying control, coordinated control of land robots, control of multiple surface and underwater vehicles), where robots exchange data through communication channels that impose constraints on the design of coordination strategies.

This research has been supported by AFOSR: 6892167.

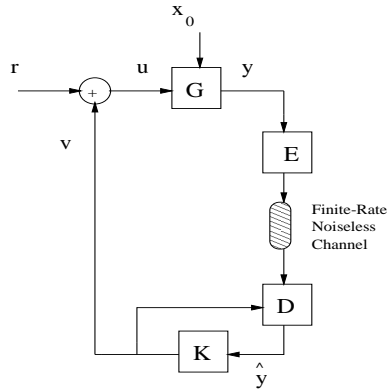

Fig. 1. Simple Feedback Network

We consider the control system shown in Figure 1. In this system, the output of the plant, G , is separated from the controller, K , by a finite-rate noiseless channel. We assume that the plant output is encoded by some operator, E , before entering the channel, and decoded by another operator, D , after exiting the channel. E and D work together to reduce the deleterious effects of the channel. The system shown in Figure 1 has the following model.

$$\begin{aligned}
 x_{t+1} &= Ax_t + B(v_t + r_t) \quad \forall t \geq 0, \\
 y_t &= Cx_t, \\
 v_t &= K(\hat{y}_t),
 \end{aligned} \tag{1}$$

where $t \in \mathbf{Z}_+$, $x_t \in \mathbf{R}^n$, and $r_t, y_t, v_t \in \mathbf{R}$.

Previous works mainly focus on some notion of state stability under finite-rate (or countable) feedback control, where the only excitation to the system is an unknown (but bounded) initial state condition ($r_t = 0$) [1], [2], [3], [4], [6], [7], [8], [10], [11], [12], [13], [16], [17], [18], [19], [20]. This research aims at finding conditions on the channel rate that will guarantee that the state of the system (or some function of the state) approach the origin/remains bounded as time goes to infinity. More recent works address synthesis of quantizers and/or performance limitations under finite-rate and finite-capacity feedback control [19], [9], [14].

In contrast, we allow for certain classes of inputs r_t to excite the system and study *input-output* stability under finite-rate feedback. Our approach introduces a computational methodology for analysis and synthesis of quantizers and controllers (E , D and K) to meet various control objectives.

Another important distinction between our work and previous studies is that we only consider encoders that have memory but do not have access to the plant input and cannot compute this control signal. When encoders have access to the control signal or can compute the control signal exactly, the plant output signal that must be communicated down to the decoder, can be described by a finite number of parameters. More concretely,

$y_t = CA^t x_0 + C \sum_{i=0}^{t-1} A^{t-1-i} B u_i$. Therefore, the only quantity unknown to E and D is x_0 , which is just a vector of n numbers that belong to a bounded set in \mathbb{R}^n . Therefore, assuming G is observable, the encoder can compute x_0 after n time steps and start transmitting x_0 through the channel down to the decoder, at a rate of R bits per time step. Consider an encoder that allocates R_i bits to the i th component of x_0 , such that $\sum_i R_i = R$, while the decoder continues to update its approximation of x_0 and x_t . The error vector then evolves as follows:

$$e_t = x_t - \hat{x}_t = A^t(x_0 - \hat{x}_{0,t}),$$

where $\hat{x}_{0,t}$ is the estimate of x_0 at time t . If we assume that A is diagonal,¹ we get the following upper bound on the magnitude of each error component:

$$|e_t(i)| \leq L \left\{ \frac{|\lambda_i(A)|}{2^{R_i}} \right\}^t \quad i = 1, 2, \dots, n,$$

where $|x_0(i)| \leq L$, for $i = 1, 2, \dots, n$. It is easy to see that if $R_i > \max(0, \log(|\lambda_i(A)|))$, for $i = 1, \dots, n$, which implies that $R > \sum_i \max(0, \log(|\lambda_i(A)|))$, then the system is asymptotically stable, since K is assumed to be stabilizing.

On the other hand, when the encoder does not have access to any signal in the loop except for the plant output, the unknown quantities characterizing y_t are x_0 and u_0, u_1, u_2, \dots , which are an infinite number of parameters. From the encoder and decoder's perspective, the output of the plant is suddenly very "rich." For any fixed t , the decoder must approximate y_0, y_1, \dots, y_t . These approximations cannot converge to their actual values, and the best strategy that E and D can employ is to improve the approximations over time by allowing E to allocate more and more bits to them (this motivates our construction of the quantizer presented in section II-A). The system boils down to a quantized feedback system, which is difficult to analyze, and where the usual tradeoff of delay versus accuracy holds.

We conclude this introduction with an overview of the paper. In section II, we describe our setup, introduce a new parameterized class of encoders that have memory but no access to the control signal, and formulate a stability problem. In section III, we derive sufficient conditions for finite-gain stability for bounded and decaying classes of reference inputs. In section IV, we show that the set of stable bit-allocation strategies implemented by our parameterized quantizers is convex, enabling synthesis of such quantizers that achieve desired objectives. In sections V and VI, we design finite-memory bit-allocation strategies and controllers that minimize the rate required for stability and that track commands for different plants. Finally, we conclude in section VII.

II. PROBLEM FORMULATION

We study system (1), in which the channel encoder has memory and no access to the control input. E is a limited-rate quantizer which has *infinite memory*, and is *time-varying* in that the strategy it follows in allocating a total of R bits to all of the inputs up to time t , is a function of t (see section II-A for details). We assume that

¹All results hold for general A matrices as shown in [18].

the channel can transmit R bits instantaneously with each use. The channel decoder, D , computes updates on the current and past values of y and sends these to the controller. K is a causal linear time-varying system described in II-B.

We define the closed-loop system to be input-output (IO) stable if for all $r \in \mathcal{C}_r$, there exists a finite positive constant α and a finite constant β such that $\|y\|_\infty \leq \alpha\|r\|_\infty + \beta$. Here, we investigate IO stability with respect to the following classes of reference inputs, \mathcal{C}_r .

- 1) **Bounded Signals:** $\mathcal{C}_r = l_{\infty, \bar{r}}$, where $l_{\infty, \bar{r}}$ is the class of all signals that are bounded in magnitude by \bar{r} .
- 2) **Decaying Signals:** $\mathcal{C}_r = \mathcal{C}_{\gamma, \bar{r}}$, where $\mathcal{C}_{\gamma, \bar{r}}$ is the class of all signals that are bounded by the positive decaying function $\bar{r}\gamma^k$ for all $k \geq 0$ and $0 < \gamma < 1$, *i.e.*, if $r \in \mathcal{C}_{\gamma, \bar{r}}$, then $|r_k| \leq \bar{r}\gamma^k$ for all $k \geq 0$.

A. Limited-Rate Time-Varying (\mathcal{R}, M) -Quantizers

Before stating the problems that we are interested in solving, we first define and model the parameterized class of time-varying infinite-memory (\mathcal{R}, M) -quantizers.

We view the quantizer as a module that approximates its input, which in general requires an infinite number of bits, with a finite number of bits. Formally speaking, an (\mathcal{R}, M) -quantizer with bit-rate R , is a sequence of causal time-varying operators, parameterized by an infinite-dimensional *rate matrix*, \mathcal{R} of the form

$$\begin{bmatrix} R_{00} & 0 & 0 & \dots & \dots \\ R_{01} & R_{11} & 0 & 0 & \dots \\ R_{02} & R_{12} & R_{22} & 0 & \dots \\ \vdots & \vdots & \vdots & \ddots & \ddots \end{bmatrix},$$

where $\sum_j R_{ij} = R - 1$ for all i , and an infinite-dimensional positive-definite diagonal *scale matrix*, $M = \text{diag}(M_{00}, M_{11}, M_{22}, \dots)$. The (\mathcal{R}, M) -quantizer saturates to output M_{kk} , the $(k + 1)^{\text{th}}$ diagonal of M , when its input, y_k , has magnitude greater than or equal to M_{kk} , *i.e.*, when $|y_k| \geq M_{kk}$. However, we denote the quantizer “valid” only when $|y_k| \leq M_{kk}$ for all $k \geq 0$, and define what the quantizer does in this case below.

Let $\hat{y}_i(j)$ be the quantized estimate of y_i at time j . Then, \mathcal{R} determines that at time $t = 0$, 1 bit is used to denote the sign of y_0 , and R_{00} bits are used to quantize the magnitude of y_0 to produce $\hat{y}_0(0)$. At time $t = 1$, an *additional* R_{01} bits are used to quantize the magnitude of y_0 to produce $\hat{y}_0(1)$; 1 bit is used to denote the sign of y_1 , and R_{11} bits are used to quantize the magnitude of y_1 to produce $\hat{y}_1(1)$, and so on. The accuracy of $\hat{y}_i(j)$ is within $\pm M_{ii} 2^{-(\sum_{k=i}^j R_{ik} + 1)}$ of y_i for all $i \geq 0$.

For the sake of analysis, the quantizer, channel, and decoder can be broken down into the five steps at any instant t as shown in Figure 2 when $|y_k| \leq M_{kk}$ for $0 \leq k \leq t$. First, the i th component of the vector y^t is scaled by $\frac{1}{M_{ii}}$ for $i = 1, 2, \dots, t$, to produce z^t , where $y^t = [y_0 \ y_1 \ \dots \ y_t]'$, and $M_t = \text{diag}(M_{00}, M_{11}, \dots, M_{tt})$. The scaling by M_t^{-1} ensures that $\|z^t\|_\infty \leq 1$. Then, each element of z^t is converted into its binary representation, *i.e.*, a string of ‘0’s and ‘1’s in the Decimal-to-Binary (D2B) converter. Next, each binary string is truncated according to the bit-allocation strategy induced by \mathcal{R} . Specifically, the binary string representing $z^t(i) = \frac{y_i}{M_{ii}}$ is truncated to contain

only its first $(\sum_{j=i}^t R_{ij})$ bits. Note that this truncation induces an error of at most $2^{-(\sum_{j=i}^t R_{ij}+1)}$ in magnitude for $z^t(i)$, i.e., $|z^t(i) - \hat{z}^t(i)| \leq 2^{-(\sum_{j=i}^t R_{ij}+1)}$.

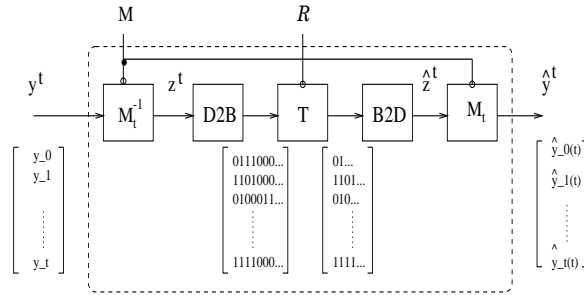

Fig. 2. Quantizer-Channel-Decoder Operator at Time t

As shown in Figure 2, the truncated binary string is converted back into its decimal representation, via the Binary-to-Decimal module (B2D), to produce \hat{z}^t . Finally, \hat{z}^t is scaled by M_t to produce \hat{y}^t , where $\hat{y}^t = [\hat{y}_0(t) \ \hat{y}_1(t) \ \hat{y}_2(t) \ \dots \ \hat{y}_t(t)]^T$. An upper bound on the error between each input component and its approximate output is:

$$|y_k - \hat{y}_k(t)| \leq M_{kk} 2^{-(\sum_{i=k}^t R_{ki}+1)},$$

$\forall k \leq t$. Stated differently, if $|y_k| \leq M_{kk}$ for $0 \leq k \leq t$, then there exists a $w_k(t)$ with $\text{sign}(w_k(t)) = \text{sign}(y_k)$ and $|w_k(t)| \leq 1 \ \forall t \geq 0$, such that

$$\hat{y}_k(t) = y_k + M_{kk} 2^{-(\sum_{i=k}^t R_{ki}+1)} w_k(t),$$

for all $k \leq t$. For analysis, we augment the output of the quantizer at time t to be the vector of *all* estimates of \mathbf{y}^t from time 0 to time t . We denote the augmented vector as $\hat{\mathbf{y}}_a^t$ as shown below.

$$\hat{\mathbf{y}}_a^t = \begin{bmatrix} \hat{y}_0(0) \\ \hat{y}_0(1) \\ \hat{y}_1(1) \\ \vdots \\ \hat{y}_0(t) \\ \hat{y}_1(t) \\ \hat{y}_2(t) \\ \vdots \\ \hat{y}_t(t) \end{bmatrix}.$$

We can then model the quantizer in its “valid” region as the following sequence of time-varying operators:

$$Q(\mathcal{R}, M) = \{Q_t : \mathbf{R}^{t+1} \rightarrow \mathbf{R}^{\frac{(t+1)(t+2)}{2}} \mid Q_t(\mathbf{y}^t) = \hat{\mathbf{y}}_a^t = I_t \mathbf{y}^t + F_t(\mathcal{R}) \overline{M}_t(M) \mathbf{w}_a^t, \ t \geq 0\},$$

where

$$I_t = \begin{bmatrix} 1 \\ \hline 1 & 0 \\ 0 & 1 \\ \hline \vdots \\ \hline I^{t \times t} \end{bmatrix},$$

and

$$F_t(\mathcal{R}) = \begin{bmatrix} f_{00} & & & \\ & f_{01} & & \\ & & f_{11} & \\ & & & \ddots \\ \hline & & & f_{0t} \\ & & & & \ddots \\ & & & & & f_{tt} \end{bmatrix}, \quad \overline{M}_t(M) = \begin{bmatrix} M_{00} & & & \\ & M_{00} & & \\ & & M_{11} & \\ & & & \ddots \\ \hline & & & & M_{00} \\ & & & & & \ddots \\ & & & & & & M_{tt} \end{bmatrix},$$

with $f_{ks} = 2^{-(\sum_{i=k}^s R_{ki}+1)}$ for $s = 0, 1, \dots, t$, and $k = 0, 1, \dots, s$.

Also,

$$\mathbf{w}_a^t = \begin{bmatrix} w_0(0) \\ \hline w_0(1) \\ w_1(1) \\ \vdots \\ \hline w_0(t) \\ w_1(t) \\ w_2(t) \\ \vdots \\ w_t(t) \end{bmatrix},$$

where $\mathbf{w}_a \in l_\infty$ such that $\|\mathbf{w}_a\|_\infty \leq 1$.

B. Plant and Controller

We represent the LTI causal system G and the causal linear time varying controller K as the following matrix multiplication operators at any time instance t :

$$G_t = \begin{bmatrix} g_0 & & & & \\ g_1 & g_0 & & & \\ g_2 & g_1 & g_0 & & \\ \vdots & & & \ddots & \\ g_t & \dots & \dots & g_1 & g_0 \end{bmatrix}, \quad K_t = \begin{bmatrix} k_0 & & & & \\ & k_1 & k_0 & & \\ & & & k_2 & k_1 & k_0 \\ \vdots & & & & & \ddots \end{bmatrix}.$$

Note that, with matrix I_t as defined above, K_t satisfies $K_t I_t = K_t^{LTI}$ where K_t^{LTI} represents a linear time invariant system given by

$$K_t^{LTI} = \begin{bmatrix} k_0 & & & & \\ k_1 & k_0 & & & \\ k_2 & k_1 & k_0 & & \\ \vdots & & \ddots & \ddots & \\ k_t & \dots & \dots & k_1 & k_0 \end{bmatrix}.$$

Figure 3 illustrates the closed-loop system at time t when the quantizer is modeled as an endogenous disturbance as described in section II-A, with

$$\mathbf{r}^t = \begin{bmatrix} r(0) \\ r(1) \\ \vdots \\ r(t) \end{bmatrix} \quad \& \quad \mathbf{u}^t = \begin{bmatrix} u(0) \\ u(1) \\ \vdots \\ u(t) \end{bmatrix}.$$

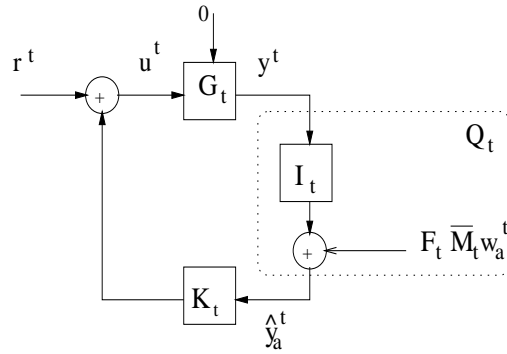

Fig. 3. Control System at Time t

From here onwards, we refer to $F_t(\mathcal{R})$ as F_t and $\bar{M}_t(M) = \bar{M}_t$ for an easier read.

C. Problem Statement

We are interested in solving the following problems.

- 1) Given G , K , \mathcal{C}_r , and a rate matrix, \mathcal{R} , determine whether there exists a set of scale matrices, M , that maintain IO stability and quantizer validity.
- 2) Given G , K , and \mathcal{C}_r , characterize the set of all rate matrices, \mathcal{R} , such that the system is IO-stable and the quantizer is valid.
- 3) Within the set of stabilizing rate matrices, find the minimum transmission rate, R , of the channel.
- 4) For a given G and \mathcal{C}_r , design K and \mathcal{R} to minimize the rate required for stability and to track commands in \mathcal{C}_r .

III. STABILITY ANALYSIS

A. Bounded Signals

In this section, we derive sufficient conditions for IO stability when $\mathcal{C}_r = l_{\infty, \bar{r}}$. Let $T_t \triangleq (I - G_t K_t^{LTI})^{-1} G_t$, then it is straightforward to show that $y^t = T_t r^t + T_t K_t F_t \bar{M}_t w_a^t$. The following theorem then gives sufficient

conditions for IO stability and quantizer validity ². Note that for a matrix A , $\|A\|_1 = \max_i \sum_j |a_{ij}|$.

Theorem 3.1: Consider system (1) with $x_0 = 0$. Let $E = Q(\mathcal{R}, M)$, for a given rate matrix \mathcal{R} , and let $r \in l_{\infty, \bar{\gamma}}$. If

- 1) $\|T\|_1 < \infty$,
- 2) $\|TKF\|_1 < 1$,

then there exists a constant scale matrix $M = mI$, such that

- (IO stability) $\|y\|_{\infty} \leq \|T\|_1 \|r\|_{\infty} + m \|TKF\|_1$,
- (quantizer validity) $\|y\|_{\infty} \leq m$.

Proof. Choose $m \geq \frac{\|T\|_1 \bar{\gamma}}{1 - \|TKF\|_1} \geq 0$, which is possible given the norm bounds on r , T , and TKF . Then,

$$\begin{aligned} \|y^t\|_{\infty} &= \sup_t \{ \|T_t r^t + T_t K_t F_t \bar{M}_t w^t\|_{\infty} \} \\ &\leq \sup_t \|T_t\|_1 \|r^t\|_{\infty} + \sup_t \|T_t K_t F_t \bar{M}_t\|_1 \\ &\leq \|T\|_1 \|r\|_{\infty} + m \|TKF\|_1 \\ &\leq m. \end{aligned}$$

The last inequality comes from our choice of m . ■

The stability condition in Theorem 3.1 is *sufficient* as we have not yet proven that $|y_k| > m$, for any $k \geq 0$, renders the system unstable. We note that memoryless, time-invariant quantizers are represented by an identity rate matrix multiplied by the value of the fixed rate $R - 1$, which leads to the following corollary.

Corollary 3.1: Consider system (1) with $x_0 = 0$. Let $E = Q(\mathcal{R}, M)$, for a *diagonal* rate matrix $\mathcal{R} = (R - 1)I$, and let $r \in l_{\infty, \bar{\gamma}}$. If

- 1) $\|T\|_1 < \infty$,
- 2) $\|TK^{LTI}\|_1 < 2^R$,

then there exists a constant scale matrix $M = mI$ such that

- (IO stability) $\|y\|_{\infty} \leq \|T\|_1 \|r\|_{\infty} + m 2^{-R} \|TK^{LTI}\|_1$,
- (quantizer validity) $\|y\|_{\infty} \leq m$.

B. Decaying Signals

We now consider the case where $r \in \mathcal{C}_{\gamma, \bar{\gamma}}$, and derive sufficient conditions for IO stability. We show that if G and K^{LTI} are finite-dimensional systems, the conditions can guarantee that the output signal, y_t , decays exponentially over time. In this section both G and K^{LTI} are assumed to be finite-dimensional systems.

²One can add an exogenous input, d , at the input of the controller and derive sufficient conditions for external stability by computing transfer functions from r and d to y and v (output of the controller). We omit the details here as the analysis is straightforward.

We know that with perfect feedback and a stabilizing K^{LTI} , exponentially decaying reference signals generate system outputs that exponentially decay over time. We would like to generate the same types of decaying responses with finite-rate feedback, and thus consider the quantizer scales, M_{tt} , to be a decaying function of t , *i.e.*, $M_t = \text{diag}(m, m\beta, m\beta^2, \dots, m\beta^t)$, where $m < \infty$ and $0 \leq \beta < 1$. The matrix $(F\overline{M})_t$ will have k th diagonal equal to $\beta^k 2^{-\sum_{i=k}^t R_{ki}}$ for $0 \leq k \leq t$, and the quantizer is valid only if $|y_t| \leq m\beta^t$ for all $t \geq 0$. Below we state a theorem that states sufficient conditions for IO stability. The details that lead to the derivation of the theorem and proof are shown in the Appendix A.

Theorem 3.2: Assume that T and TK^{LTI} are finite-dimensional *stable* LTI systems, whose corresponding A matrices (of state-space descriptions) have spectral radii ρ and ν , respectively (both ρ and ν have magnitudes less than 1). Denote $\{T\}_i$ and $\{TK^{LTI}\}_i$ as the i th components ($i = 0, 1, \dots$) of the impulse responses of T and TK , respectively. Given system (1), $r \in \mathcal{C}_{\gamma, \bar{r}}$, and a rate matrix \mathcal{R} , if

- 1) $\{T\}_i \leq \eta_1 \rho^i$ ($0 \leq \eta_1 < \infty$) for all $i \geq 0$,
- 2) $\{TK^{LTI}\}_i \leq \eta_2 \nu^i$ ($0 \leq \eta_2 < \frac{1}{\|F\|_1}$) for all $i \geq 0$,
- 3) $\max(\nu, \rho, \gamma)(1 - \eta_2 \|F\|_1) > \nu$,

then there exists a decaying scale matrix M ($M_{kk} = m\beta^k$) such that

- (IO stability) $\|y\|_\infty \leq \|T\|_1 \|r\|_\infty + m \|TK\|_1$,
- (quantizer validity) $|y_t| \leq m\beta^t \quad \forall t \geq 0$.

IV. CHARACTERIZATION OF STABLE RATE MATRICES

We have shown that if $\|TKF\|_1 < \eta$ for $\eta > 0$, then the system is IO-stable for bounded and decaying inputs. This inequality can be written as a set *convex* constraints on the rate matrix parameters. The following theorem shows this result.

Theorem 4.1: Let $X = \{\text{vec}(\mathcal{R})\}^3 = [R_{00} \ R_{01} \ R_{02} \ \dots \ R_{11} \ R_{12} \ \dots]^T$, then for any infinite dimensional matrix, P , the condition $\|PF(X)\|_1 < \eta$ is convex in X for any $\eta > 0$.

Proof.

$$\|PF(X)\|_1 < \eta \Leftrightarrow \sum_{j=0}^{\infty} f_j(X) |P_{ij}| < \eta \quad i = 0, 1, \dots$$

where $f_j(X) = 2^{-\sum_{i=j}^{\infty} R_{ji}}$. We now show that $f_j(X)$ is convex in X , and thus any non-negative combination of $f_j(X)$ is convex. First, we recall that 2^{-a} is a convex function in a . Let $2^{-(\sum_{i=j}^{\infty} R_{ji+1})} = 2^{-(c'_j X+1)}$, where c'_j is an appropriate row vector for $j = 0, 1, \dots$. Note that

$$\begin{aligned} 2^{-\lambda(c'_j X_1+1) - (1-\lambda)(c'_j X_2+1)} &= 2^{-\lambda(a_1+1) - (1-\lambda)(a_2+1)} \\ &\leq \lambda 2^{-(a_1+1)} + (1-\lambda) 2^{-(a_2+1)} \\ &= \lambda 2^{-(c'_j X_1+1)} + (1-\lambda) 2^{-(c'_j X_2+1)}. \end{aligned}$$

³The “vec” operator on a matrix simply concatenates all the column to form one large column vector.

■

If we let $P = TK$, then we get that the stability condition, $\|TKF\|_1 < \eta$, is a set of convex constraints on the infinite dimensional vector $vec(\mathcal{R})$. This result enables the search for the most efficient quantizer to be formulated as a convex optimization problem.

V. SYNTHESIS: MINIMIZING CHANNEL RATE

In this section we synthesize (R, M) -quantizers and time-varying controllers for different plants to minimize the rate required for IO stability for $\mathcal{C}_r = l_{\infty, \bar{r}}$. In particular, we set out to solve the following problem.

$$\begin{aligned}
 & \min_{K^{LTI}, \mathcal{R}} R & (2) \\
 & \text{s.t. } \|T\|_1 < \infty, \\
 & \|TKF(\mathcal{R})\|_1 < 1, \\
 & \sum_j R_{ij} = R - 1 \quad i = 0, 1, \dots \\
 & R_{ij} \geq 0 \quad j \leq i = 0, 1, \dots
 \end{aligned}$$

where $T = (I - GK^{LTI})^{-1}G$. We make a few comments regarding our approach to solve (3).

- 1) The (\mathcal{R}, M) -quantizer is described by an infinite number of parameters (R_{ij}) as it has infinite memory. To make things easily computable and more practical, we restrict ourselves to finite-memory (\mathcal{R}, M) -quantizers, defined below in section V-A, each of which is described by a finite number of parameters.
- 2) The optimization problem (3) has constraints that are non-convex in both K^{LTI} and \mathcal{R} and therefore is not efficiently solvable. We propose an iterative algorithm, described below in section V-B, that alternates between computing a controller and quantizer. In each computation, we solve a convex optimization problem subject to convex constraints. We show that our iterative algorithm has a nonincreasing cost and therefore converges to a local minimum. Numerical examples are given in section V-C.

A. Finite-Memory (\mathcal{R}, M) -Quantizers

We consider a special class of practical quantizers that have finite memory and are periodic. Specifically, each value of y gets approximated by the quantizer for *at most* N consecutive time steps. In fact, for any $t \geq 0$, y_{tN+j} gets approximated for $N - j$ time steps, for $j = 0, 1, \dots, N - 1$. Moreover, the bit-allocation strategy repeats every N time steps. We call this class of quantizers, “repeated-block” (RB) quantizers because the structure of the rate matrix is block diagonal as shown below. $\mathcal{R} =$

Each block is the following $N \times N$ matrix:

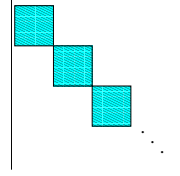

$$R_{block} = \begin{bmatrix} R_{00} & & & \\ R_{01} & R_{11} & & \\ \vdots & \vdots & \ddots & \\ R_{0,N-1} & R_{1,N-1} & \dots & R_{N-1,N-1} \end{bmatrix}.$$

It is useful to highlight that RB quantizers are time-invariant operators in “lifted” coordinates, where each time step in the lifted coordinates is equivalent to N time steps in original coordinates. We define the following lifted signals for $t \geq 0$:

$$\tilde{\mathbf{r}}_t = \begin{bmatrix} r_{tN} \\ r_{tN+1} \\ \vdots \\ r_{(t+1)N-1} \end{bmatrix}, \quad \tilde{\mathbf{y}}_t = \begin{bmatrix} y_{tN} \\ y_{tN+1} \\ \vdots \\ y_{(t+1)N-1} \end{bmatrix}, \quad \tilde{\mathbf{w}}_t = \begin{bmatrix} w_{tN}((t+1)N-1) \\ w_{tN+1}((t+1)N-1) \\ \vdots \\ w_{(t+1)N-1}((t+1)N-1) \end{bmatrix}.$$

The model for a repeated-block quantizer, Q_{RB} , in the lifted coordinates, denoted \tilde{Q}_{RB} , is:

$$Q_{RB}(\mathcal{R}, M) = \{\tilde{Q}_{RB} : \mathbf{R}^N \rightarrow \mathbf{R}^N \mid \tilde{Q}_{RB}(\tilde{\mathbf{y}}) = \tilde{\hat{\mathbf{y}}} = I_N \tilde{\mathbf{y}} + m \tilde{F}_N \tilde{\mathbf{w}}\},$$

where, written as a matrix multiplication operator, $\tilde{F}_N = \text{diag}(F_{N-1}, F_{N-1}, \dots)$ and $I_N = I_t$ evaluated at $t = N$. The closed-loop system in lifted coordinates is shown in Figure 4.

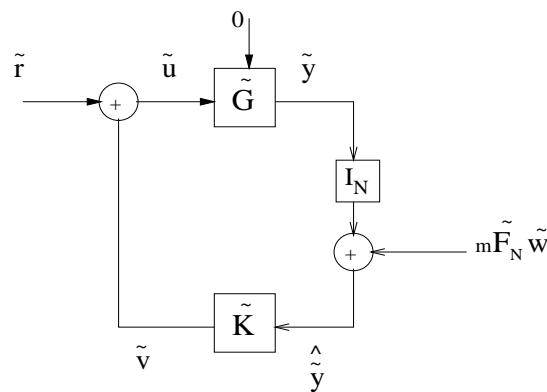

Fig. 4. Lifted Closed-Loop System

After lifting by a factor of N , the plant \tilde{G} is LTI with N inputs and N outputs and the controller \tilde{K} becomes LTI with $\frac{N(N+1)}{2}$ inputs and N outputs. This enables us to use existing control tools for LTI systems to synthesize

\tilde{K} .

We state sufficient conditions for IO stability for bounded signals in the lifted coordinate space with arbitrary linear time-varying controllers, but first state the following Lemma whose proof is straightforward and left to the reader.

Lemma 5.1: Let P be any causal LTI SISO system, and \tilde{P} is a lifted version of P with lift factor N . Then, for any $N \geq 1$, $\|\tilde{P}\|_1 \geq \|P\|_1$.

Theorem 5.1: Consider system (1) with an arbitrary time-varying controller lifted by a factor of N , with $x_0 = 0$. Let $E = Q_{RB}(\mathcal{R}, M)$, for a given repeated-block rate matrix \mathcal{R} , and let $r \in l_{\infty, \overline{\mathcal{F}}}$. If

- 1) $\|(I - \tilde{G}\tilde{K}^{LTI})^{-1}\tilde{G}\|_1 < \infty$, and
- 2) $\|(I - \tilde{G}\tilde{K}^{LTI})^{-1}\tilde{G}\tilde{K}\tilde{F}_N\|_1 < 1$,

then the original system is IO-stable.

Proof. If condition (1) and (2) hold, then by invoking Lemma 5.1, we get that $\|(I - GK^{LTI})^{-1}G\|_1 < \infty$, and $\|(I - GK^{LTI})^{-1}GKF\|_1 < 1$. From Theorem 3.1, we then get that the original system (un-lifted) is IO stable. ■

B. \mathcal{R} - K Iteration

The \mathcal{R} - K iteration algorithm proposed here efficiently computes a locally optimal controller and finite-memory repeated-block quantizer that solves (3). The algorithm is described in the box below. Note that $\tilde{T} = (I - \tilde{G}\tilde{K}_0^{LTI})^{-1}\tilde{G}$.

\mathcal{R} - K Iteration Algorithm

- 1) For a given plant G , pick any stabilizing controller, K_0^{LTI} . Pick a convergence threshold $\epsilon > 0$ and set $c = 0$.
- 2) Solve the following problem to construct \mathcal{R}_c :

$$\begin{aligned} & \min_{\mathcal{R}} R & (3) \\ & \|\tilde{T}\tilde{K}_c\tilde{F}_N(\mathcal{R})\|_1 < 1, \\ \text{s.t. } & R = 1 + \sum_j R_{ij} \quad i = 0, 1, \dots, N-1, \\ & R_{ij} \geq 0 \quad j \leq i = 0, 1, \dots, N-1. \end{aligned}$$

Note that the above problem has constraints that are convex in all unknown parameters R_{ij} as shown in section IV and is therefore efficiently computable using any standard convex optimization software. We demonstrate how we use MATLAB's 'fmincon.m' function to solve (4) in Appendix B. If $c \geq 1$ and if $R_{c-1} - R_c \leq \epsilon$ then STOP. Else goto Step 3.

- 3) Fix \mathcal{R}_c and compute new controller K_{c+1} by solving

$$\begin{aligned} & \min_{K^{LTI}} \|\tilde{T}\tilde{K}\tilde{F}_N(\mathcal{R}_c)\|_1 \\ \text{s.t. } & \|\tilde{T}\|_1 < \infty \end{aligned}$$

Since the constraint is not convex in K^{LTI} , apply ‘‘Q-Parameterization’’ or ‘‘Youla Parameterization’’ to parameterize all stabilizing controllers and convert the above problem to a convex optimization problem of the form:

$$\begin{aligned} & \min_Q \|H_0 - H_1QH_2\|_1 & (4) \\ \text{s.t. } & Q \text{ LTI stable, rational, and proper,} \end{aligned}$$

where H_0 , H_1 and H_2 are derived from the system to equate $\|\tilde{T}\tilde{K}\tilde{F}_N(\mathcal{R}_0)\|_1$ to $\|H_0 - H_1QH_2\|_1$. Note that there is a one-to-one relationship with \tilde{K}_{c+1} and Q given by the parameterization. We omit details as this is a common procedure and refer the reader to [5], [15] for details. Note that (5) is again efficiently computable using any standard convex optimization software.

- 4) Increment c by 1 and goto Step 2.

The above algorithm continues to iterate between the two optimization problems until both costs fail to change

TABLE I
EXAMPLE 1

Step 1	$G = \frac{10}{z+1}$	$K_0 = \frac{-0.075z^2 - 0.075z - 0.075}{z^3}$	$\epsilon = 1.5$
Step 2	$R_{block,0} = \begin{bmatrix} 1.4171 & & & \\ 0.2621 & 1.1551 & & \\ & 0.4907 & 0.9265 & \\ & & 0.2665 & 1.1507 \end{bmatrix}$	$R_0 = 2.4171$	$R_{ml} = 2.6792$
Step 3	$K_1 = \frac{-0.04375z^2 - 0.01074z + 0.001745}{z^3}$	$\ \tilde{T}\tilde{K}_0\tilde{F}_N(\mathcal{R}_0)\ _1 = 1$	$\ \tilde{T}\tilde{K}_1\tilde{F}_N(\mathcal{R}_0)\ _1 = 0.2252$
Step 2	$R_{block,1} = \mathbf{0}$	$R_1 = 1$	$(R_0 - R_1) = 1.4171 < \epsilon$

more than a given ϵ . This iteration will converge to a local minimum rate required for stability as described in the following Proposition .

Proposition 5.1: The \mathcal{R} - K iteration algorithm has a nonincreasing cost in the channel rate R and therefore converges to a local minimum.

Proof. For a given plant and controller suppose we have just computed rate matrix \mathcal{R}_c with rate R_c for some positive integer c . Given \mathcal{R}_c , the iteration algorithm then computes a controller K_{c+1} that minimizes the bias $\|\tilde{T}\tilde{K}\tilde{F}_N(\mathcal{R}_c)\|_1$ by solving (5) and converting Q back to \tilde{K} . Then we get that $\|\tilde{T}\tilde{K}_{c+1}\tilde{F}_N(\mathcal{R}_c)\|_1 \leq \|\tilde{T}\tilde{K}\tilde{F}_N(\mathcal{R}_c)\|_1$ for all controllers \tilde{K} . Next, we compute a rate matrix \mathcal{R}_{c+1} that minimizes the channel rate required for stability subject to the constraint that $\|\tilde{T}\tilde{K}_{c+1}\tilde{F}_N(\mathcal{R})\|_1 < 1$. Note that \mathcal{R}_c is a feasible solution, therefore $R_{c+1} \leq R_c$. ■

C. Examples

We now execute one iteration of the \mathcal{R} - K iteration algorithm for three different unstable plants with $\bar{r} = 1$ and $N = 4$ (memory size of quantizer). We summarize the results for each plant in separate tables. In each case, we give the initial controller K_0 used to compute repeated-block quantizer \mathcal{R}_0 which is entirely characterized by $R_{block,0}$. We also compare the rate R_0 to the minimum rate R_{ml} obtained if we restrict the quantizer to be memoryless and time-invariant (a diagonal rate matrix). Note that the minimum channel rate R_0 required for stability for each corresponding closed-loop system is $R_{block,0}(1,1) + 1$. We then show the controller K_1 computed by fixing the quantizer to be parameterized by \mathcal{R}_0 and the corresponding quantizer bias term $\|\tilde{T}\tilde{K}_0\tilde{F}_N(\mathcal{R})\|_1$. Finally, we fix the controller to K_1 and compute \mathcal{R}_1 to complete one iteration.

From Tables 1-3, we see that $R_0 < R_{ml}$ in all cases indicating that allowing the quantizer to have memory and

TABLE II
EXAMPLE 2

Step 1	$G = \frac{10}{z+1.5}$	$K_0 = \frac{-0.072z^2 - 0.0216z - 0.00648}{z^3}$	$\epsilon = 1$
Step 2	$R_{block,0} = \begin{bmatrix} 2.1630 & & & & \\ 0.1830 & 1.9800 & & & \\ & 0.3580 & 1.8050 & & \\ & & 0.1847 & 1.9783 & \\ & & & & \end{bmatrix}$	$R_0 = 3.163$	$R_{mt} = 3.3461$
Step 3	$K_1 = \frac{-0.1173z^2 - 0.05309z - 0.01148}{z^3}$	$\ \tilde{T}\tilde{K}_0\tilde{F}_N(\mathcal{R}_0)\ _1 = 1$	$\ \tilde{T}\tilde{K}_1\tilde{F}_N(\mathcal{R}_0)\ _1 = 0.4731$
Step 2	$R_{block,1} = \begin{bmatrix} 1.2131 & & & & \\ 0.2875 & 0.9255 & & & \\ & 0.5750 & 0.6380 & & \\ & & 0.2876 & 0.9255 & \\ & & & & \end{bmatrix}$	$R_1 = 2.213$	$(R_0 - R_1) = 0.95 < \epsilon$

TABLE III
EXAMPLE 3

Step 1	$G = \frac{10}{z+2}$	$K_0 = \frac{-0.144z^2 - 0.0576z - 0.02304}{z^3}$	$\epsilon = 1.1$
Step 2	$R_{block,0} = \begin{bmatrix} 4.4267 & & & & \\ 0.2284 & 4.1982 & & & \\ & 0.4329 & 3.9938 & & \\ & & 0.2271 & 4.1996 & \\ & & & & \end{bmatrix}$	$R_0 = 5.4267$	$R_{mt} = 5.6551$
Step 3	$K_1 = \frac{-0.1841z^2 - 0.08769z - 0.01779}{z^3}$	$\ \tilde{T}\tilde{K}_0\tilde{F}_N(\mathcal{R}_0)\ _1 = 1$	$\ \tilde{T}\tilde{K}_1\tilde{F}_N(\mathcal{R}_0)\ _1 = 0.2915$
Step 2	$R_{block,1} = \begin{bmatrix} 3.4036 & & & & \\ 0.2692 & 3.1344 & & & \\ & 0.5298 & 2.8738 & & \\ & & 0.2683 & 3.1353 & \\ & & & & \end{bmatrix}$	$R_1 = 4.4036$	$(R_0 - R_1) = 1.0231 < \epsilon$

to allocate bits to the past maintains stability for channels with smaller rates than in the case where the quantizer is memoryless and does not allocate to the past. In addition, the more unstable the plant, the more rate required for closed-loop stability. Finally, one iteration shows a marked improvement in rate required for stability as $R_1 < R_0$ in all cases.⁴

VI. SYNTHESIS: TRACKING COMMANDS

In this section we synthesize limited-rate finite-memory (R, M) -quantizers and time-varying controllers for a given plant to track a family of bounded reference commands $\mathcal{C}_r = l_{\infty, \bar{r}}$ such that the rate is limited by a given \bar{R} . In particular, we set out to solve the following problem.

$$\begin{aligned}
 \min_{K, L, T, \mathcal{R}} \quad & \|T - I\|_1 + m \|TKF_N(\mathcal{R})\|_1 & (5) \\
 \text{s.t.} \quad & \|T\|_1 < \infty, \\
 & \|T\|_1 + m \|TKF_N(\mathcal{R})\|_1 \leq m, \\
 & \sum_j R_{ij} = R - 1 \quad i = 0, 1, \dots \\
 & R_{ij} \geq 0 \quad j \leq i = 0, 1, \dots \\
 & R \leq \bar{R}
 \end{aligned}$$

Minimizing the cost function $\|T - I\|_1 + m \|TKF_N(\mathcal{R})\|_1$ is a tracking objective. From Figure 3, we get that the tracking error is $y - r = (T - I)r + TKF_N(\mathcal{R})\bar{M}w_a$. Therefore, $\|y - r\|_\infty \leq \|T - I\|_1 + m \|TKF_N(\mathcal{R})\|_1$, where m ensures quantizer validity $\|T\|_1 + m \|TKF_N(\mathcal{R})\|_1 \leq m$. Therefore, the lower bound on m depends on \mathcal{R} and K .

Again, we will restrict ourselves to repeated-block quantizers and will apply an iteration algorithm to minimize tracking cost. We outline the iteration algorithm below.

⁴Note that 3rd-order finite impulse response controllers were designed to simplify computation and are shown in Tables 1-3. Searching over all FIR controllers is not optimal, yet we are still able to demonstrate the validity of our synthesis algorithms.

\mathcal{R} - K Iteration Tracking Algorithm

- 1) For a given plant G and rate limit \bar{R} , pick any stabilizing controller, K_0 , a positive constant m and a convergence threshold $\epsilon > 0$. Set $c = 0$.
- 2) Solve the following problem to construct \mathcal{R}_c :

$$\begin{aligned}
 & \min_{\mathcal{R}} \quad \|\tilde{T} - I\|_1 + m\|\tilde{T}\tilde{K}_c\tilde{F}_N(\mathcal{R})\|_1 & (6) \\
 & \text{s.t.} \quad R = 1 + \sum_j R_{ij} \quad i = 0, 1, \dots, N-1, \\
 & \quad \quad R_{ij} \geq 0 \quad j \leq i = 0, 1, \dots, N-1. \\
 & \quad \quad R \leq \bar{R}, \\
 & \quad \quad \|\tilde{T}\|_1 + m\|\tilde{T}\tilde{K}_c\tilde{F}_N(\mathcal{R})\|_1 \leq m.
 \end{aligned}$$

Note that the above problem has cost and constraints that are convex in all unknown parameters R_{ij} and is therefore efficiently computable using any standard convex optimization software. Denote the resulting optimal tracking cost as γ_c . If the problem is infeasible, then increase m and goto Step 2. If $c \geq 1$ and if $\gamma_{c-1} - \gamma_c \leq \epsilon$ then STOP. Else goto Step 3.

- 3) Fix \mathcal{R}_c and compute new controller K_{c+1} by solving

$$\begin{aligned}
 & \min_{K^{LTI}} \quad \|I - \tilde{T}\|_1 + m\|\tilde{T}\tilde{K}\tilde{F}_N(\mathcal{R}_c)\|_1 \\
 & \text{s.t.} \quad \|\tilde{T}\|_1 < \infty \\
 & \quad \quad \|\tilde{T}\|_1 + m\|\tilde{T}\tilde{K}\tilde{F}_N(\mathcal{R}_c)\|_1 \leq m.
 \end{aligned}$$

Since the constraint is not convex in K^{LTI} , apply ‘‘Q-Parameterization’’ or ‘‘Youla Parameterization’’ to parameterize all stabilizing controllers and convert the above problem to a convex optimization problem of the form:

$$\begin{aligned}
 & \min_Q \quad \|V_0 - V_1 Q V_2\|_1 & (7) \\
 & \text{s.t.} \quad Q \text{ LTI stable, rational, proper,} \\
 & \quad \quad \|f_1(Q)\|_1 + m\|f_2(Q)\|_1 \leq m,
 \end{aligned}$$

where V_0 , V_1 and V_2 are derived from the system to equate $\|I - \tilde{T}\|_1 + m\|\tilde{T}\tilde{K}\tilde{F}_N(\mathcal{R}_c)\|_1$ to $\|V_0 - V_1 Q V_2\|_1$ and f_1 and f_2 are affine functions in Q such that $\|f_1(Q)\|_1 + m\|f_2(Q)\|_1$ equals $\|\tilde{T}\|_1 + m\|\tilde{T}\tilde{K}\tilde{F}_N(\mathcal{R}_c)\|_1$. Note that (8) is again efficiently computable using any standard convex optimization software.

TABLE IV
TRACKING EXAMPLE 1

Step 1	$G = \frac{10}{z+1}$	$(\bar{R} = 5, m = 20)$	$K_0 = \frac{-0.0368z^2 - 0.0006z + 0.0026}{z^3}$
Step 2	infeasible	infeasible	infeasible

We fix m in Step 1 of the algorithm and check to make sure that the quantizer remains valid for that chosen value of m in both (6) and (7). Keeping m as a function of \mathcal{R} and K would not enable convexity of the subproblems (6) and (7). One can find the smallest m over all \mathcal{R} and K such that the quantizer remains valid and minimizes the tracking cost by applying the above iteration algorithm to different values of m , changing m via a bisection algorithm.

It is straightforward to see that the tracking iteration algorithm described above always results in a nonincreasing tracking cost.

A. Examples

We now execute one iteration of the \mathcal{R} - K iteration tracking algorithm for one unstable plant and different (\bar{R}, m) pairs. We set $\bar{\tau} = 1$ and summarize the results for each example in separate tables. In each case, we give the initial controller K_0 used to compute repeated-block quantizer \mathcal{R}_0 which is entirely characterized by $R_{block,0}$ and its tracking cost. We then show the controller K_1 computed by fixing the quantizer to be parameterized by \mathcal{R}_0 , and the corresponding bound on the 1-norm of the tracking error. Finally, we fix the controller to K_1 and compute \mathcal{R}_1 to complete one iteration.

From Tables 4-8, we make a few observations.

- If either m or \bar{R} is too small, the problem may be infeasible. Recall that the quantizer is valid only if validity $\|y\|_\infty \leq m$, so if m is too small then norm of y is forced to be small which limits input-output behavior. If \bar{R} is too small, the the channel restricts the feedback control input too much to achieve tracking.
- If we fix m and increase \bar{R} the tracking error cost improves. This makes sense as the channel becomes less restrictive as \bar{R} increases.
- If we fix \bar{R} and increase m , the tracking error cost increases. This also makes sense because as m increases, the cost $\|I - \tilde{T}\|_1 + m\|\tilde{T}\tilde{K}_0\tilde{F}_N(\mathcal{R}_0)\|_1$ also increases (for a fixed controller and quantizer).
- The tracking cost in just one iteration is decreasing as $\gamma_0 - \gamma_1$ is positive for all examples.
- Although we do not show results for memoryless quantizers, we observed that quantizers with finite memory perform better than memoryless quantizers in tracking as well.

We note that 3rd-order finite impulse response controllers were designed to simplify computation and are shown

TABLE V
TRACKING EXAMPLE 2

Step 1	$G = \frac{10}{z+1}$	$(\bar{R} = 10, m = 30)$	$K_0 = \frac{-0.0368z^2 - 0.0006z + 0.0026}{z^3}$
Step 2	$R_{block,0} = \begin{bmatrix} 9.0000 & & & & \\ 0.0500 & 8.9500 & & & \\ & 0.0975 & 8.9025 & & \\ & & & 0.0532 & 8.9468 \end{bmatrix}$	$R_0 = 10$	$\gamma_0 = 30.9563$
Step 3	$K_1 = \frac{-0.06532z^2 - 0.03061z - 0.007916}{z^3}$	$\ I - \tilde{T}\ _1 +$ $m\ \tilde{T}\tilde{K}_0\tilde{F}_N(\mathcal{R}_0)\ _1 = 30.9563$	$\ I - \tilde{T}\ _1 +$ $m\ \tilde{T}\tilde{K}_1\tilde{F}_N(\mathcal{R}_0)\ _1 = 25.0942$
Step 2	$R_{block,1} = \begin{bmatrix} 9.0000 & & & & \\ & 9.0000 & & & \\ & & & 9.0000 & \\ & & & & 0.0899 & 8.9101 \end{bmatrix}$	$R_1 = 10$	$\gamma_1 = 25.0917$ $(\gamma_0 - \gamma_1) = 5.8647$

TABLE VI
TRACKING EXAMPLE 3

Step 1	$G = \frac{10}{z+1}$	$(\bar{R} = 15, m = 30)$	$K_0 = \frac{-0.0368z^2 - 0.0006z + 0.0026}{z^3}$
Step 2	$R_{block,0} = \begin{bmatrix} 14.0000 & & & & \\ 8.6722 & 5.3278 & & & \\ & 5.9975 & 8.0025 & & \\ & & & 3.0004 & 10.9996 \end{bmatrix}$	$R_0 = 15$	$\gamma_0 = 30.9326$
Step 3	$K_1 = \frac{-0.06527z^2 - 0.03054z - 0.007872}{z^3}$	$\ I - \tilde{T}\ _1 +$ $m\ \tilde{T}\tilde{K}_0\tilde{F}_N(\mathcal{R}_0)\ _1 = 30.9326$	$\ I - \tilde{T}\ _1 +$ $m\ \tilde{T}\tilde{K}_1\tilde{F}_N(\mathcal{R}_0)\ _1 = 25.0594$
Step 2	$R_{block,1} = \begin{bmatrix} 14.0000 & & & & \\ & 14.0000 & & & \\ & 1.8799 & 12.1201 & & \\ & & & 0.9405 & 13.0595 \end{bmatrix}$	$R_1 = 15$	$\gamma_1 = 25.0474$ $(\gamma_0 - \gamma_1) = 5.8875$

TABLE VII
TRACKING EXAMPLE 4

Step 1	$G = \frac{10}{z+2}$	$(\bar{R} = 15, m = 50)$	$K_0 = \frac{-0.0368z^2 - 0.0006z + 0.0026}{z^3}$
Step 2	$R_{block,0} = \begin{bmatrix} 14.0000 & & & & \\ 5.1680 & 8.8320 & & & \\ & 3.5761 & 10.4239 & & \\ & & 1.7834 & 12.2166 & \\ & & & & \end{bmatrix}$	$R_0 = 15$	$\gamma_0 = 30.9305$
Step 3	$K_1 = \frac{-0.06416z^2 - 0.02832z - 0.005319}{z^3}$	$\ I - \tilde{T}\ _1 + m\ \tilde{T}\tilde{K}_0\tilde{F}_N(\mathcal{R}_0)\ _1 = 30.9305$	$\ I - \tilde{T}\ _1 + m\ \tilde{T}\tilde{K}_1\tilde{F}_N(\mathcal{R}_0)\ _1 = 25.4943$
Step 2	$R_{block,1} = \begin{bmatrix} 14.0000 & & & & \\ & 14.0000 & & & \\ & 0.4685 & 13.5315 & & \\ & & 0.4673 & 13.5327 & \\ & & & & \end{bmatrix}$	$R_1 = 15$	$\gamma_1 = 25.4895$ $(\gamma_0 - \gamma_1) = 5.4410$

TABLE VIII
TRACKING EXAMPLE 5

Step 1	$G = \frac{10}{z+1}$	$(\bar{R} = 15, m = 20)$	$K_0 = \frac{-0.0368z^2 - 0.0006z + 0.0026}{z^3}$
Step 2	infeasible	infeasible	infeasible

in Tables 4-8. Searching over all FIR controllers is not optimal (also what is infeasible with FIR controllers may be feasible for IIR controllers), yet we are still able to demonstrate the validity of our iteration algorithm. Finally, our results are dependent on the initial selection of K_0 and initial conditions of 'fmincon.m'.

VII. CONCLUSIONS

In summary, we consider a plant and feedback controller separated by a finite-rate noiseless channel and we study a new class of encoders that have memory but do not have access to the control input to the plant. If the encoder is not local to the plant and if it does not know what controller will receive the signal it sends through the channel, then it can be modeled as belonging to this class. We have constructed a parameterization of time-varying

quantizers that belong to this encoder class, and that leads to a convex characterization of bit-allocation strategies that maintain finite-gain stability. For finite memory quantizers, the convex characterization of stabilizing quantizers allows for efficient and non-trivial bit-allocation strategies and controllers to be synthesized for a given plant to meet various performance objectives.

In the future, we would like to obtain necessary conditions that maintain input-output stability.

VIII. APPENDIX

A. Proof of Theorem 3.2

Below, we make some observations that lead to Theorem 3.2 and its proof. We assume the following norm conditions,

- 1) $\|T\|_1 < \infty$,
- 2) $\|TK^{LTI}\|_1 < \infty$,

and break down y_t as follows:

$$y_t = (Tr)_t + (TKF\bar{M}w)_t = yr_t + yq_t.$$

Under the first assumption, we show that there exists a positive finite constant C_1 and an α_1 ($0 \leq \alpha_1 < 1$), such that $|yr_t| \leq C_1\alpha_1^t$, for all $t \geq 0$.

Assuming that $\|T\|_1 < \infty$, there exists a ρ , with $0 \leq \rho < 1$, and a positive finite constant η_1 , such that $|\{T\}_i| \leq \eta_1\rho^i$, for all $i \geq 0$. $\{T\}_i$ is the i th value of the impulse response of T . In fact, ρ can be chosen to be the spectral radius of the stable A matrix of a state-space description for T . Since T is LTI, $yr_t = \sum_{i=0}^t \{T\}_{t-i}r_i$, therefore,

$$\begin{aligned} |yr_t| &\leq \sum_{i=0}^t |\{T\}_{t-i}| |r_i| \\ &\leq \bar{\tau} \sum_{i=0}^{\infty} \eta_1 \rho^{t-i} \gamma^i \\ &= \eta_1 \bar{\tau} \rho^t \sum_{i=0}^{\infty} \left(\frac{\gamma}{\rho}\right)^i \\ &= \frac{\eta_1 \bar{\tau} \rho}{\rho - \gamma} \rho^t, \end{aligned}$$

where the last equality holds if $\gamma < \rho < 1$. Similarly, $|yr_t| = |\sum_{i=0}^t \{T\}_i r_{t-i}| \leq \frac{\eta_1 \bar{\tau} \gamma}{\gamma - \rho} \gamma^t$, if $\rho < \gamma < 1$. Putting both cases together, we get that

$$|yr_t| \leq C_1 \alpha_1^t,$$

for all $t \geq 0$, where

$$C_1 = \max\left(\frac{\eta_1 \bar{\tau} \gamma}{\gamma - \rho}, \frac{\eta_1 \bar{\tau} \rho}{\rho - \gamma}\right), \quad \alpha_1 = \max(\rho, \gamma).$$

Under the second assumption, $\|TK^{LTI}\|_1 < \infty$, we show that there exists a positive finite constant C_2 and a constant α_2 ($0 \leq \alpha_2 < 1$), such that $|yq_t| \leq C_2\alpha_2^t$, for all $t \geq 0$.

Since $\|TK^{LTI}\|_1 < \infty$, there exists a constant ν , with $0 \leq \nu < 1$, and a positive constant η_2 , such that $|\{TK^{LTI}\}_i| \leq \eta_2 \nu^i$, for all $i \geq 0$. We now look at the magnitude of the response due to the exogenous disturbance induced by the quantizer, yq_t .

$$\begin{aligned} |yq_t| &= |\sum_{j=0}^t T_{t-j} \sum_{i=0}^j K_{j-i}^{LTI} m \beta^i 2^{-\sum_{i=0}^j R_{i1}} w_i(j)| \\ &\leq m \|F\|_1 |\sum_{j=0}^t \sum_{i=0}^j T_{t-j} K_{j-i}^{LTI} \beta^i| \\ &\leq m \|F\|_1 \sum_{j=0}^t |TK_{t-j}^{LTI}| \beta^j \\ &\leq \eta_2 m \|F\|_1 \sum_{j=0}^{\infty} \nu^{t-j} \beta^j \\ &= \eta_2 m \|F\|_1 \nu^t \sum_{j=0}^{\infty} \left(\frac{\beta}{\nu}\right)^j \\ &= \frac{\|F\|_1 \eta_2 m \nu}{\nu - \beta} \nu^t, \end{aligned}$$

where the last equality holds if $\beta < \nu < 1$. If $\nu < \beta < 1$, then it is easy to show that $|yq_t| \leq \frac{\|F\|_1 \eta_2 m \beta}{\beta - \nu} \beta^t$. We then get that

$$|yq_t| \leq C_2 \alpha_2^t,$$

for all $t \geq 0$, where

$$C_2 = \max\left(\frac{\|F\|_1 m \eta_2 \beta}{\beta - \nu}, \frac{\|F\|_1 m \eta_2 \nu}{\nu - \beta}\right), \quad \alpha_2 = \max(\nu, \beta).$$

Recall that β is a parameter we are looking for to ensure that $|y_t| \leq m \beta^t$. Therefore, $\beta \geq \nu$, which gives us

$$C_2 = \frac{\|F\|_1 m \eta_2 \beta}{\beta - \nu}, \quad \alpha_2 = \beta.$$

Putting everything together, we get that for all $t \geq 0$,

$$|y_t| \leq |yr_t| + |yq_t| \leq C_1 \alpha_1^t + \frac{\|F\|_1 m \eta_2 \beta}{\beta - \nu} \beta^t.$$

For the quantizer to be valid, we require $|y_t| \leq m \beta^t$, for all $t \geq 0$. The above observations lead us to the following proof.

Proof:

Define $C_1 = \max\left(\frac{\eta_1 \bar{\tau} \gamma}{\gamma - \rho}, \frac{\eta_1 \bar{\tau} \rho}{\rho - \gamma}\right)$, as computed in section III-B above. Then choose $\beta = \max(\rho, \nu, \gamma)$ and $m = \frac{C_1}{1 - \frac{\eta_2 \beta \|F\|_1}{\beta - \nu}}$. It is straightforward to show that m is finite and positive due to condition (3). To show input-output stability, we have

$$\begin{aligned} \|y^t\|_{\infty} &= \sup_t \{ \|T_t G_t \mathbf{r}^t + T_t G_t K_t F_t M_t \mathbf{w}^t\|_{\infty} \} \\ &\leq \|T\|_1 \|r\|_{\infty} + m \|TKF\|_1 \\ &\leq \|T\|_1 \|r\|_{\infty} + m \|TK\|_1. \end{aligned}$$

where the last inequality comes from the fact that $\|F\|_1 \leq 1$. To show quantizer validity, we computed in section III-B above that for $\alpha_1 = \max(\rho, \gamma)$,

$$\begin{aligned} |y_t| &\leq C_1 \alpha_1^t + \frac{\|F\|_1 m \eta_2 \beta}{\beta - \nu} \beta^t \\ &\leq m \beta^t, \end{aligned} \quad (8)$$

where the last inequality comes from our choices of β and m .

B. Using MATLAB's 'fmincon.m' to Synthesize Quantizers

In this section, we show how we use MATLAB to solve the following optimization problem.

$$\begin{aligned} & \min R \\ \text{s.t. } & \sum_j R_{ij} = R - 1 \quad i = 0, 2, \dots, N - 1, \end{aligned} \quad (9)$$

$$\|(I - \tilde{G}\tilde{K}^{LTI})^{-1}\tilde{G}\tilde{K}\tilde{F}_N\|_1 < 1, \quad (10)$$

$$R_{ij} \geq 0 \quad j \leq i = 0, 1, \dots, N - 1, \quad (11)$$

For a given G and K^{LTI} , we lift the original system by a factor of N and denote the state-space description of $(I - \tilde{G}\tilde{K}^{LTI})^{-1}\tilde{G}\tilde{K}$ by $(\tilde{A}_{cl}, \tilde{B}_{cl}, \tilde{C}_{cl}, \tilde{D}_{cl})$. Let $X \triangleq \text{vec}(R_{block})$ and rewrite the above optimization problem as

$$\begin{aligned} & \min X_1 \\ \text{s.t. } & A_{eq}X = B_{eq}, \\ & P(X) < 0, \\ & X \geq 0, \end{aligned}$$

where $A_{eq}X = B_{eq}$ captures the equality constraints (2), $P(X) < 0$ captures constraints (3) and $X \geq 0$ are equivalent to constraints (4). For example, if $N = 4$, then

$$R_{block} = \begin{bmatrix} R_{00} & & & \\ R_{01} & R_{11} & & \\ R_{02} & R_{12} & R_{22} & \\ R_{03} & R_{13} & R_{23} & R_{33} \end{bmatrix},$$

- [2] Wong, Wing Shing, Brockett, Roger, "Systems with Finite Communication Bandwidth Constraints-I: State Estimation Problems," *IEEE Transactions on Automatic Control*: vol. 42, no. 9, September 1997.
- [3] Brockett, Roger W., "Quantized Feedback Stabilization of Linear Systems," *IEEE Transactions on Automatic Control*: vol. 45, pp. 1279-1289, 2000.
- [4] Wong, Wing Shing, Brockett, Roger, "Systems with Finite Communication Bandwidth Constraints-II: Stabilization with Limited Information Feedback," *IEEE Transactions on Automatic Control*: vol. 44, no. 5, May 1999.
- [5] Dahleh, M.A., Diaz-Bobillo, I., "Control of Uncertain Systems: A Linear Programming Approach," Prentice Hall, 1995.
- [6] Delchamps, David, "Stabilizing a Linear System with Quantized State Feedback," *IEEE Transactions on Automatic Control*: vol. 35, no. 8, August 1990.
- [7] Elia, Nicola, Mitter, Sanjoy "Stabilization of Linear Systems With Limited Information," *IEEE Transactions on Automatic Control*: vol. 46, no. 9, September 2001.
- [8] Fagnani, Fabio, Zampieri, Sandro, "Stability Analysis and Synthesis for Linear Systems With Quantized Feedback," *IEEE Transactions on Automatic Control*: vol. 48, no. 9, 2003.
- [9] Fagnani, Fabio, Zampieri, Sandro, "Quantized Stabilization of Linear Systems: Complexity Versus Performance," *IEEE Transactions on Automatic Control*: vol. 49, no. 9, 2004.
- [10] Ishii, Hideaki, Francis, Bruce, "Limited data rate in control systems with networks," *Berlin; New York: Springer*, c2002.
- [11] Ling, Q, Lemmon MD, "Stability of quantized control systems under dynamic bit assignment," *IEEE Transactions on Automatic Control*: vol. 50, Issue 5, May 2005 Page(s): 734-740.
- [12] Liberzon, Daniel, "A note on stabilization of linear systems using coding and limited communication," *Proceedings of the 41st IEEE Conference on Decision and Control*, December 2002.
- [13] Martins, N.C., Elia N., Dahleh M.A., "Stabilization of Uncertain Systems in the Presence of a Direct Link", *IEEE Transactions on Automatic Control*: March 2006, page(s):438 - 447.
- [14] Martins, N. C. and Dahleh, M. A.; Feedback Control in the Presence of Noisy Channels: Bode-Like Fundamental Limitations of Performance, *IEEE Transactions on Automatic Control* (Accepted).
- [15] Megretski, A. Lecture Notes for 6.245: Multivariable Control Systems, Q-Parameterization Chapter. MIT, 2004.
- [16] Nair, G.N., Evans, R.J., "Stabilization with Data-rate-limited Feedback: tightest attainable bounds," *Systems and Control Letters*, volume 41, 2000, pp. 49-56.
- [17] Nair, G.N., Evans, R.J. "Stabilizability of stochastic linear systems with finite feedback data rates", *SIAM Journal on Control and Optimization, Society for Industrial and Applied Mathematics, USA*, vol. 43, no. 2, pp. 413 - 436, July 2, 2004.
- [18] Tatikonda, Sekhar, "Control Under Communication Constraints," *IEEE Transactions on Automatic Control* : Volume 49, Issue 7, July 2004 Page(s): 1056 - 1068.
- [19] Tatikonda, Sekhar, Sahai, Anant, Mitter, Sanjoy, "Control of LQG Systems Under Communication Constraints," *Proceedings of the American Control Conference*: pp 2778-2782, June 1999.
- [20] Yuksel, Serder, Basar, Tamer, "State Estimation and Control for Linear Systems over Communication Networks," *Proceedings of 2003 IEEE Conference on Control Applications*, Volume 1, June 2003.



Sridevi V. Sarma Sri Sarma received her B.S. degree from Cornell University in Electrical Engineering in 1994 and her PhD in 2006 from Massachusetts Institute of Technology in the department of Electrical Engineering and Computer Science. Sri is now a postdoctoral fellow at Harvard Medical School conducting research in Computational Neuroscience. Her research interests include control over networks (theory and applications in neuroscience), and large-scale modeling and optimization. Sri received her MS in the Laboratory of Computer Science at MIT, during which she gained expertise in speech recognition technology. She applied this knowledge to a project involving phonetic classification at Digital Equipment Corporation. Sri is also cofounder of Infolenz Corporation, a Marketing Analytics company in Cambridge, MA. Sri has taught numerous undergraduate courses at MIT in probability theory, signal processing and systems and signals. She has also taught a graduate level course in dynamic systems. She is a former National Science Foundation fellow and a recipient of the GE faculty for the future scholarship.



Munther A. Dahleh Munther A. Dahleh was born in 1962. He received the B.S. degree from Texas A & M university, College Station, Texas in 1983, and his Ph.D. degree from Rice University, Houston, TX, in 1987, all in Electrical Engineering. Since then, he has been with the Department of Electrical Engineering and Computer Science, MIT, Cambridge, MA, where he is now a full Professor. He has been a visiting Professor at the Department of Electrical Engineering, California Institute of Technology, Pasadena, CA, for the Spring of 1993. He has held consulting positions with several companies in the US and abroad. Dr. Dahleh has been the recipient of the Ralph Budd award in 1987 for the best thesis at Rice University, George Axelby outstanding paper award (paper coauthored with J.B. Pearson in 1987), an NSF presidential young investigator award (1991), the Finmeccanica career development chair (1992) and the Donald P. Eckman award from the American Control Council in 1993, the Graduate Students Council teaching award in 1995, the George Axelby outstanding paper award (paper coauthored with Bamieh and Paganini in 2004), and the Hugo Schuck Award for Theory (for the paper coauthored with Martins). He became a fellow of IEEE in year 2000. He was a plenary speaker at the 1994 American Control Conference, at the Mediterranean Conference on Control and Automation in 2003, and at the MTNS in 2006. He was an Associate Editor for IEEE Transactions On Automatic Control and for Systems and Control Letters. He is the co-author (with Ignacio Diaz-Bobillo) of the book *Control of Uncertain Systems: A Linear Programming Approach*, published by Prentice-Hall, and the co-author (with Nicola Elia) of the book *Computational Methods for Controller Design* published by Springer. Dr. Dahleh is interested in problems at the interface of robust control, filtering, information theory, and computation which include control problems with communication constraints and distributed mobile agents with local decision capabilities. He is also interested in model reduction problems for discrete-alphabet hidden markov models and universal learning approaches for systems with both continuous and discrete alphabets. He is also interested in the interface between systems theory and neurobiology, and in particular, in providing an anatomically consistent model of the motor control.



Srinivasa Salapaka Srinivasa M Salapaka received B.Tech. degree in Mechanical Engineering from Indian Institute of Technology at Chennai, India in 1995, the M.S. and the Ph.D. degrees in Mechanical Engineering from the University of California at Santa Barbara, U.S.A in 1997 and 2002, respectively. During 2002-2004, he was a postdoctoral associate in the Laboratory for Information and Decision Systems, Massachusetts Institute of Technology, Cambridge, USA. He joined the department of Mechanical Science and Engineering at the University of Illinois, Urbana-Champaign in January 2004. His research is in the areas of Control and Dynamical Systems, Optimization and Computation with focus on the areas of Nano Science and Technology, Combinatorial Optimization, and Convolution Integral Equations. He is a recipient of 2005 National Science Foundation CAREER award.