

Project: MIL-STD-1553

The MIL-STD-1553 is a military standard that defines the electrical and protocol characteristics for a data bus. The standard was released in 1973 with the primary user being the Air Force's F-16. Since that time, it has undergone two revisions, *Notice 1*, released in 1980 and the tri-service *Notice 2* in 1986. The *Notice 2* to the standard removed all references to 'aircraft' or 'airborne' so as not to limit usage of the bus. Outside of the military domain, it has been successfully applied to e.g., the BART (Bay Area Rapid Transit) subway system and manufacturing production lines. We use 1553 to refer to the protocol architecture defined in the MIL-STD-1553.

1553 Network Architecture

The transmission media is defined by the standard as a shielded twisted pair transmission line consisting of the main bus and a number of stubs. The Figure 1 below shows the basic multiplexed architecture.

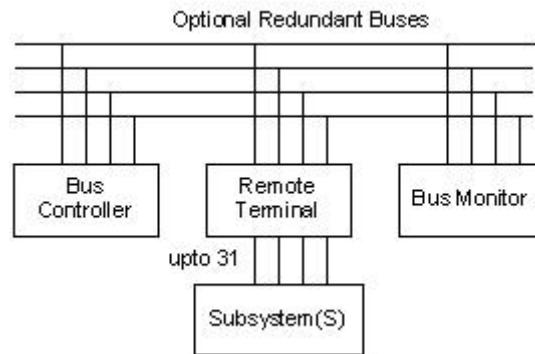

Figure 1. 1553 Multiplex Architecture

The Bus Controller (BC) is responsible for directing the flow of traffic on the data bus. Typically this function is contained within some other computer such as a mission computer, a display processor, or a fire control computer. The standard does not define the internal working of the bus controller, only that it issues commands on the bus.

A Bus Monitor (BM) is a terminal that listens to the exchange of information on the bus. The standard clearly defines that information obtained from a bus monitor may only be used for "Off-Line applications" or to provide a backup BC with enough information to take over as a bus controller. All terminals on the bus that are not acting like a BC or a BM are termed Remote Terminals (RT). An RT typically consists of a transceiver, an encoder/ decoder, a protocol controller, a buffer or memory, and a sub-system interface. It can only respond to commands from the BC. On receiving a valid command, the RT must respond within a finite closely defined amount of time.

Bus Access

The control, data flow, status reporting and bus management functions of the bus are provided by three word types: Command words, Data words and Status words. All three

words have a common structure but each has a unique format as shown in Figure 2. Each word is twenty bits in length, allowing the decode clock to resynchronize at the beginning of each new word. The next sixteen bits are data bits and the last bit is a parity bit. The parity computed is odd parity.

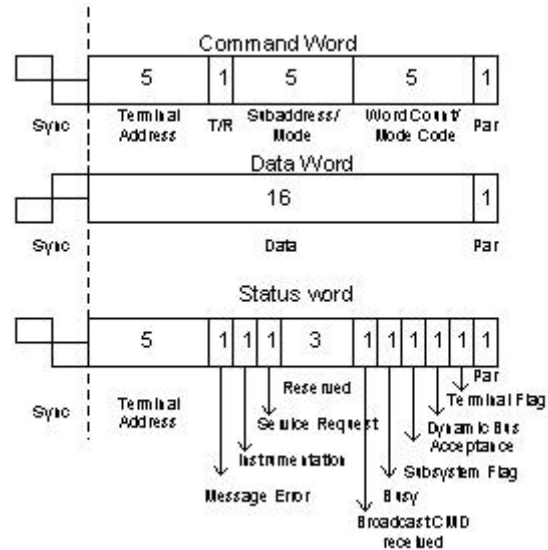

Goal:

- Write an Ada95 program to simulate the behavior of a bus controller
- Write an Ada95 program to simulate the behavior of a remote terminal.
- Can you run both tasks (controller and remote terminal) on the same machine?
- How will you validate your design?
- The USAF is designing a new aircraft and wants your input on the bus architecture to use. Based on your experience in this project, write a two page memo explaining the advantages and disadvantages of 1553 over other available bus architectures.

Links of Use:

<http://www.1553-mil-std.com/mil-std-1553-tutorial.html>

<http://www.1553.com/1553interp.htm>